

# POSTILLA

Published from 1950 to 2004, the short papers of the *Postilla* series reported on original research by the Yale Peabody Museum of Natural History's curators, staff, and research associates, and their colleagues, in the natural science disciplines represented by the collections of the Museum's curatorial divisions.

The *Postilla* series, which ceased publication with Number 232 (2004), was incorporated into the journal *Bulletin of the Peabody Museum of Natural History*, available from BioOne Complete at <https://bioone.org/>.

Yale Peabody Museum scholarly publications are archived through EliScholar, a digital platform for scholarly publishing provided by Yale University Library at <https://elischolar.library.yale.edu/>.



This work is licensed under a Creative Commons Attribution-NonCommercial-ShareAlike 4.0 International License.  
<https://creativecommons.org/licenses/by-nc-sa/4.0/>

**Yale** PEABODY MUSEUM OF NATURAL HISTORY

---

P.O. Box 208118 | New Haven CT 06520-8118 USA | [peabody.yale.edu](http://peabody.yale.edu)



**The Ordovician Trilobite  
*Hadrohybus* Raymond 1925,  
and Its Family Relationships**

**R. A. Fortey**

(Received 17 September 1987)

**Abstract**

The type species of the trilobite *Hadrohybus* Raymond 1925, *H. dunbari* from the Cow Head Group of western Newfoundland, is redescribed here. It has been regarded as a cheirurid, but analysis of its cranidial characters show that it is a bathyurid closely related to the well-known Early Ordovician genus *Bolbocephalus*, and it is considered to be a subgenus of that form. It is probably of early Middle Ordovician age. A second *Hadrohybus* species occurs in the late Early Ordovician of Vermont.

**Key Words**

*Hadrohybus*, *Bolbocephalus*, Bathyuridae, trilobite, Ordovician.

**Introduction**

Raymond (1925) described the type, and only named species of *Hadrohybus*, from the Ordovician, Cow Head Group of western Newfoundland. On the basis of these cranidia, Raymond considered that the genus was a cheirurid related to *Nieszkowskia*, and this

placement has remained, although *Hadrohybus* was only placed with question in Cheiruridae by Henningsmoen (*in* Moore, 1959) in the *Treatise on Invertebrate Paleontology*. Raymond's original illustrations were somewhat perfunctory, and a reconsideration of this peculiar trilobite is overdue. This paper reviews the family relationships of *Hadrohybus*.

**Age of *Hadrohybus dunbari* Occurrence**

The Cow Head Group of western Newfoundland consists of a series of conglomerates with interbedded shales and sandstone, which accumulated off the shelf-edge of the Laurentian continent during the Cambrian to Ordovician. The conglomerates were mostly derived from shallow water environments, and from one boulder of this type the specimens of *Hadrohybus* were recovered. James and Stevens (1986, fig. 40) record a succession on the type locality, Stearing Island, ranging through Early Ordovician to Early Whiterockian. Only two conglomerates yield pebbles large enough to have furnished the large *Hadrohybus* specimens. One of these is of Arenig age and is high in the Lower Ordovician. The other, of possible late Arenig age, may be the equivalent of the massive conglomerate bed of nearby Lower Head, and may be regarded as Whiterockian (Whittington 1963). On my visit to Stearing Island I was unable to find further specimens of *Hadrohybus* and direct evidence of its age is so far lacking. Raymond (1925) lists '*Eoharpes fragilis*, *Homotelus catactus*, *Iliaenus* sp. and *Pliomerops*

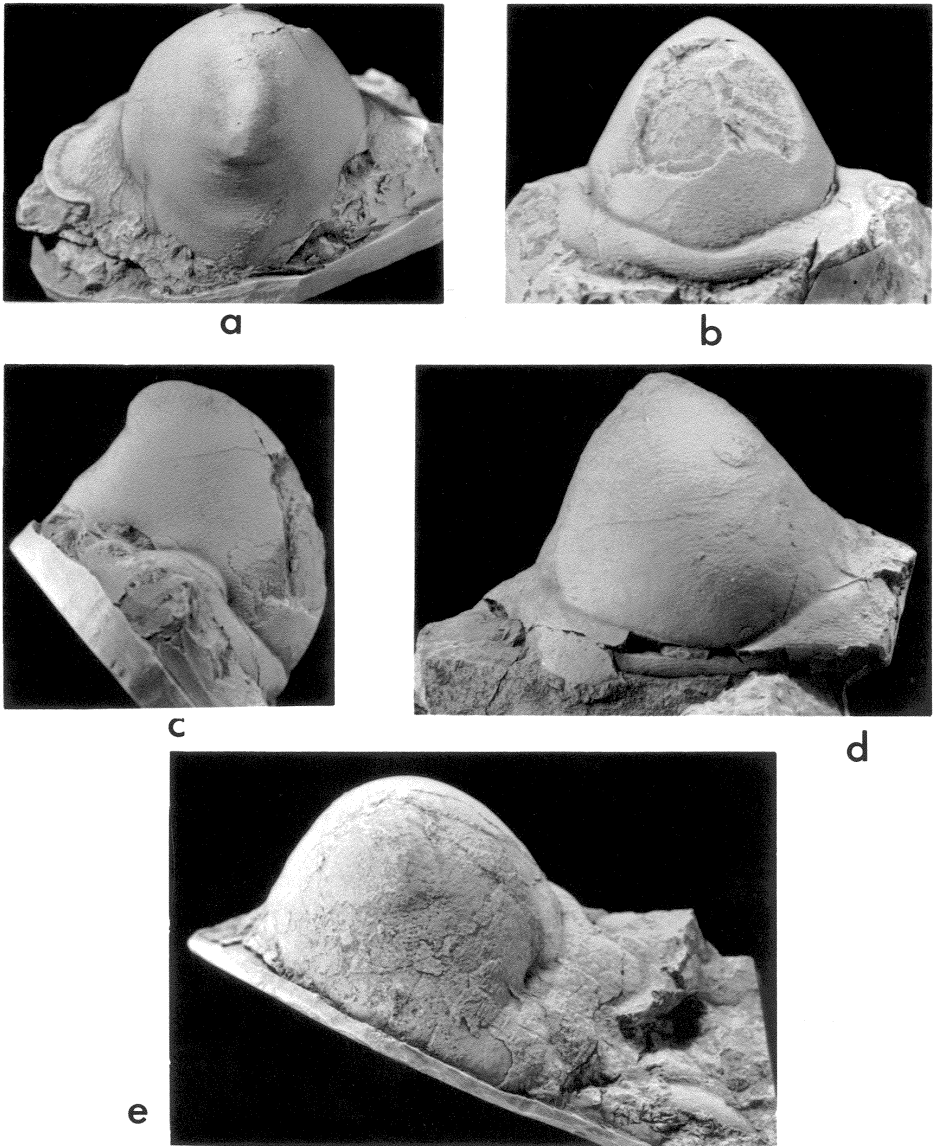

**Fig. 1**

*Hadrohybus dunbari* Raymond. *a-c*, holotype cranidium YPM 13031,  $\times 1.5$  in dorsal, anterior and lateral views; *d, e*, paratype, large incomplete cranidium, but showing postocular cheek,  $\times 1$ , YPM 13030, in anterior and dorsal views. Photographs of replicas supplied to the author by the Peabody Museum of Natural History (YPM), Yale University.

*barrandei*" as associated species with *Hadrohybus*. This assemblage appears most comparable with that described from the Lower Head boulder by Whittington (1963), and if this is the case it seems likely that the boulder yielding *Hadrohybus* is of Whiterockian age.

### Systematic Note

Genus *Bolbocephalus* Whitfield, 1890  
Subgenus *Hadrohybus* Raymond 1925

### Type Species

(Original designation) *H. dunbari* Raymond 1925

*Bolbocephalus (Hadrohybus) dunbari* Raymond 1925 (Fig. 1a–e)

*Hadrohybus dunbari* sp. nov.: Raymond, 1925, p. 147–48, pl. 9, figs. 5, 6.

*Hadrohybus dunbari* Raymond: Henningsmoen, 1959, in Moore 1959, p. 435.

### Type Material

Holotype, cranium, YPM 13031; paratype, cranium, YPM 13030.

### Type Locality and Horizon

Steering Island, Cow Head, western Newfoundland, pebble in probably early Middle Ordovician conglomerates.

### Description

Cranidium is large and highly convex (sagittal, transverse), with glabella highly vaulted and curving downward anteriorly, so that in dorsal view it overhangs cranial margin. Maximum cranial width at posterior margin; postocular cheek gently declined downwards. Glabella tapers forward initially, but expands in width at level of palpebral lobes to achieve maximum width at their anterior ends; anterior outline broadly rounded, but anterior view shows tendency toward an obtuse anteromedian acumination. Occipital ring not

seen on type material. Glabellar furrows effaced, but oval areas adjacent to the shallow axial furrows opposite posterior parts of palpebral lobes presumably represent muscle insertion areas. At a point opposite the palpebral lobes the glabella is elevated into a prominent, slightly backward-turned knob, forming the conspicuous high point of the cranium. Preglabellar area short, vertical to reclined, but cranial anterior border apparently lacking. Palpebral lobes highly curved, and approximately medially placed in dorsal view forming semicircles, anterior ends closer to glabella than posterior ends, and with clearly defined palpebral rims. Sutures do not diverge in front of palpebral lobes, thereby defining narrow (transverse), downsloping preocular cheeks. Area inside palpebral lobes gently inflated. Postocular suture describes a sigmoidal curve, in the midpart running more or less transversely, the postocular cheeks evidently wide (transverse) and showing at least the proximal part of a moderately defined posterior border furrow. The cranium carries a distinctive surface sculpture best shown on the smaller example. Fine tubercles cover the glabella, and these are joined by raised lines on the glabellar flanks. The raised lines are most prominent on the front of the glabella, as they are on the preglabellar area. The interocular fixed cheeks are rugose.

### Discussion

Only the cranium of *H. dunbari* is known and comparative remarks are accordingly limited. However, a second species which can be attributed to *Hadrohybus* was described by Whittington (1953) as *Bolbocephalus?* species indeterminate. This species is from the Fort Cassin Formation of Vermont, which is of late Early Ordovician age. Again, only the cranium is known, and this is clearly like that of *H. dunbari*, although much smaller than either of the types of this species. The glabellar boss is prominent on the Vermont form, but further forward on the glabella (Whittington 1953, pl. 66, fig. 15), and directed somewhat forward. The surface sculpture apparently consists of much finer, concentric

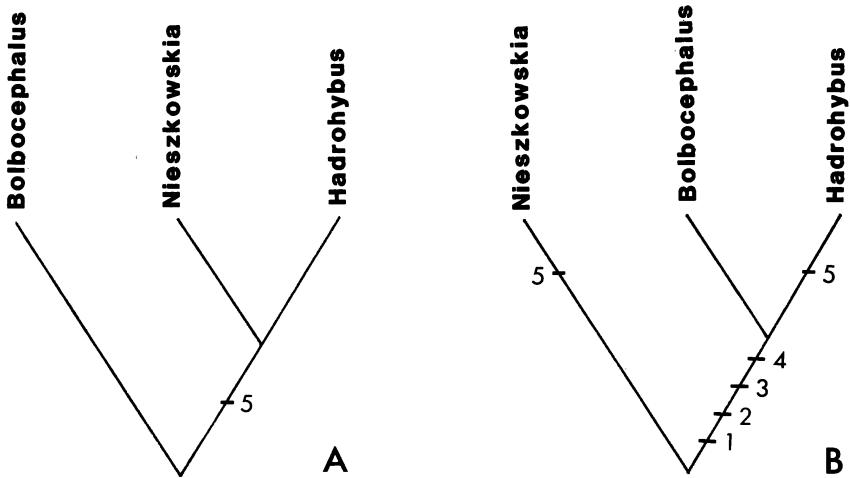

**Fig. 2.**

Competing hypotheses of relationships of *Hadrohybus*. A, Cheirurid relationships; B, Bathyurid relationships. A greater number of cranial synapomorphic characters favor B, which is adopted in this paper. Characters are: 1, waisted glabella; 2, opisthoparian sutures; 3, glabellar effacement; 4, terrace ridges present; 5, glabellar boss. Under hypothesis B the glabellar boss is a parallelism.

lines on the glabella. These differences are sufficient to indicate that the Vermont form is a separate species from *H. dunbari*. The single specimen of a cranidium, however, is not considered an adequate basis for formally naming it.

### Family Assignment of *Hadrohybus*

Raymond (1925) compared the morphology of *Hadrohybus* with that of the cheirurid *Nieszkowskia*, a family into which it was placed with question by Henningsmoen (*in* Moore 1959). This assignment appears to rest mainly on the presence of the curious glabellar boss in both genera. This resemblance is misleading as far as family relationships are concerned (Fig. 2). Here it is considered that *Hadrohybus* is closely related

to the bathyurid *Bolbocephalus* Whitfield 1890, a well-known genus from the early Ordovician of North America. Because of its previous assignment to Cheiruridae, *Hadrohybus* was not considered in the revision of Bathyuridae by Whittington (1953) or Fortey (1979).

Certain characters shown on *Hadrohybus* are present on representatives of both bathyurids and cheirurids and hence are not relevant to deciding familial relationships. These include the presence of tuberculate surface sculpture, the deeply incised palpebral furrow and the anteriorly rounded glabella. However, the ridgelike sculpture of the anterior border is not present on any cheirurid of which we are aware.

The type species of *Bolbocephalus* is *B. seelyi* (Whitfield 1886) from Vermont which was redescribed by Whittington (1953). Fortey (1979) recently redescribed *B. convexus*

(Billings 1865) from the Catoche Formation of western Newfoundland; this species offers a particularly close comparison with *Hadrohybus*. Neglecting the glabellar boss, the outline and forward protrusion of the glabella in both cases is identical, as is the absence of defined glabellar furrows. So is the position and curved form of the palpebral lobe, and the long (transverse) postocular cheek. There is no evidence that the facial suture of *Hadrohybus* is proparian, which of course it would have to be were *Hadrohybus* a cheirurid; the preservation of the only type specimen which shows the postocular cheek is admittedly imperfect.

Surface sculpture on *Bolbocephalus* species consists of terrace ridges, or it is smooth, but the related bathyurid *Petigurus* has very coarse tuberculation and the sculptural difference is probably not important.

Additionally, the following cheirurid characters are absent on *Hadrohybus*: 1) Incised posterior glabellar furrow. Even on relatively effaced cheirurids the basal glabellar furrow is well defined and backward curved, and there is no sign of this furrow on *Hadrohybus*. 2) Anterior cranial border. A narrow (sagittal) anterior cranial border which does not continue the downward slope of the frontal glabellar lobe is typical of cheirurids. When the border is encroached upon by the glabella, as in sphaerexochinids, it becomes almost obsolete, but in no cheirurid is there the flat, downsloping preglabellar area shown on *Hadrohybus*. 3) Genal sculpture. The usual sculptural type on the genal areas of cheirurids included a honeycomblike arrangement of pits as well as tuberculation, which is not present on *Hadrohybus*.

In summary, very little evidence supports

the hypothesis that *Hadrohybus* is a cheirurid, and many facts suggest that it is not. It is closely comparable to a known bathyurid of similar age and provenance. The discovery of the free cheek and pygidium of *Hadrohybus* can be expected to confirm this family assignment. The resemblance between the glabellar boss of *Hadrohybus* and the cheirurid *Nieszkowskia* is regarded as the result of probable convergence.

### **Position of *Hadrohybus* within the Bathyuridae**

The close comparison between *Hadrohybus* and *Bolbocephalus* has been discussed above. There remains the question of whether *Hadrohybus* should be accorded separate generic status or subgeneric status within an enlarged concept of *Bolbocephalus*. *Petigurus* is the most closely related bathyurid to *Bolbocephalus* (Fortey 1979) and is the sister group to *Bolbocephalus* and *Hadrohybus*. Figure 3 shows the distribution of characters of the cranidia of these genera, together with *Bathyurus* as the typical bathyurine. This shows there are really no characters which can be regarded as autapomorphic for *Hadrohybus* cranidia apart from the glabellar boss, whereas *Bolbocephalus* and *Hadrohybus* have several additional autapomorphies, about the same number as *Petigurus*. All these taxa form a compact subgroup within Bathyurinae. The best recourse for the moment is to regard *Hadrohybus* as a subgenus of *Bolbocephalus*, based on the glabellar boss, because there are two species showing this distinctive character. Discovery of the free cheek and pygidium of *Hadrohybus* may add additional characters.

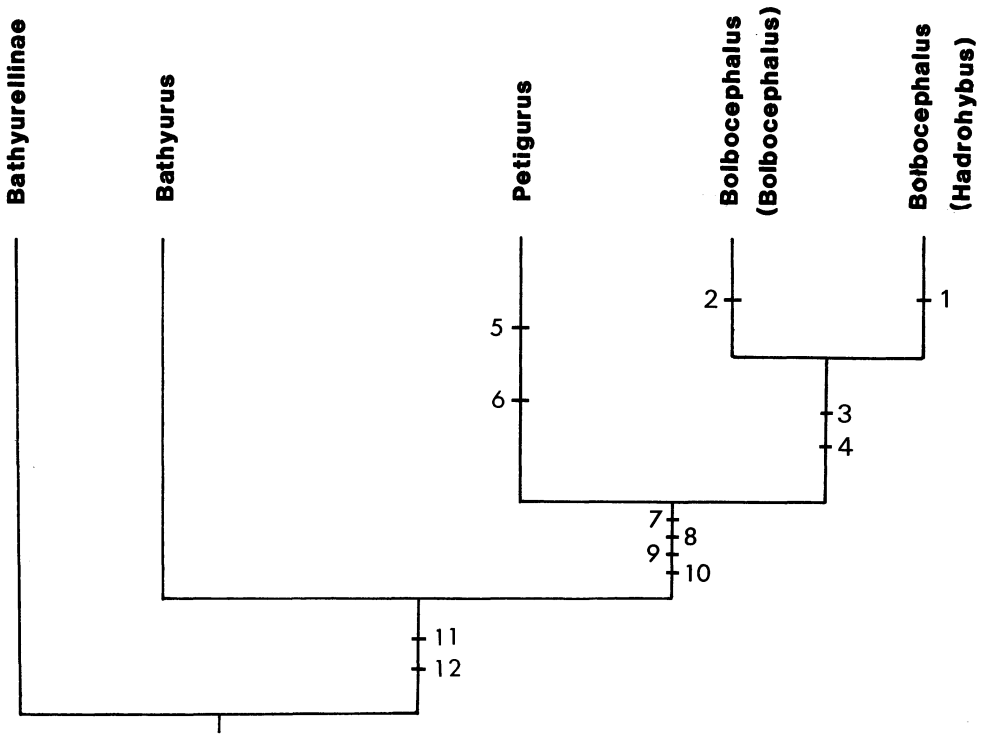

**Fig. 3.**

Cladogram of relationships of *Hadrohybus* within Bathyuridae, based on cranial characters.

*Bathyurus*, shown as the sister group of *Petigurus* + *Bolbocephalus*, does not have cranial autapomorphies and its recognition depends on the pygidium. Derived characters are: 1, glabellar boss; 2, sculpture of terrace ridges; 3, waisted glabella; 4, loss of typical bathyurid tuberculation; 5, exceptionally thick cuticle; 6, very coarse glabellar tuberculation; 7, large size; 8, glabella protrudes over cranial margin; 9, deep palpebral furrows; 10, loss of horizontal anterior cranial border; 11, rounded and tumid frontal glabellar lobe; 12, tuberculate sculpture.

---

## Literature Cited

- Billings, E.** 1865. Palaeozoic Fossils. Vol. 1. Containing descriptions and figures of new or little known species of organic remains from the Silurian rocks. 1861–1865. Montreal, Geol. Surv. Canada.
- Fortey, R. A.** 1979. Early Ordovician trilobites from the Catoche Formation (St. George Group), western Newfoundland. *Bull. Geol. Surv. Canada* 321:61–114.
- Henningsmoen, G.** 1959. Cheiruridae, p. 431–38. *In* R. C. Moore (ed.), *Treatise on Invertebrate Paleontology*. Part O. New York City, Geol. Soc. Am. and Univ. Kansas Press.
- James, N. P.** and **R. K. Stevens.** 1986. Stratigraphy and correlation of the Cambro–Ordovician Cow Head Group, western Newfoundland. *Bull. Geol. Surv. Canada* 366:1–143.
- Moore, R. C.** (ed.) 1959. *Treatise on Invertebrate Paleontology*. Part O. Trilobita. New York City, Geol. Soc. Am. and Univ. Kansas Press. 560 p.
- Raymond, P. E.** 1925. Some trilobites of the Lower Middle Ordovician of Eastern North America. *Bull. Mus. Comp. Zool., Harvard Univ.* 67(1):1–180, 10 pls.
- Whitfield, R. P.** 1886. Notice of geological investigations along the eastern shore of Lake Champlain, conducted by Prof. H. M. Seely and Prest. Ezra Brainerd, of Middlebury College, with descriptions of the new fossils discovered. *Bull. Am. Mus. Nat. Hist.* 1:293–345, pls. 24–34.
- 1890. Observations on the fauna of the rocks at Fort Cassin, Vermont, with descriptions of a few new species. *Bull. Am. Mus. Nat. Hist.* 3:25–39, pls. 1–3.
- Whittington, H. B.** 1953. North American Bathyruridae and Leiestegiidae (Trilobita). *J. Paleont.* 27:647–78.
- 1963. Middle Ordovician trilobites from Lower Head, western Newfoundland. *Bull. Mus. Comp. Zool., Harvard Univ.* 129(1):1–118, 36 pls.

---

## The Author

**R. A. Fortey.** Department of Paleontology,  
British Museum (Natural History), Cromwell  
Road, London SW7 5BD, England.