

EOSAM 2021

Guest editors: Concita Sibilìa, Alessandro Belardini and Gilles Pauliat

RESEARCH ARTICLE

OPEN ACCESS

Study of injection-locked stabilized, short cavity Brillouin ring laser source design for fiber sensing applications

Leonardo Rossi¹, Filippo Bastianini², and Gabriele Bolognini^{3,*}

¹ Consiglio Nazionale delle Ricerche, IMM Institute, Bologna 40129, Italy

² Sestosensor srl, R&D Department, Zola Predosa 40069, Italy

³ Consiglio Nazionale delle Ricerche, IMM Institute, Bologna 40129, Italy

Received 1 February 2022 / Accepted 22 July 2022

Abstract. A new pump-seeded, short-cavity Brillouin ring laser source layout intended for Brillouin sensing applications is showcased, showing increased high maximum output (1.5 mW), a strong linewidth narrowing effect (producing light with a linewidth of 10 kHz) and limited relative intensity noise (RIN ~ -145 dB/Hz), providing an ultranarrow, highly stable BRL source that can also be employed as a pump-probe source for Brillouin optical time-domain analysis (BOTDA) applications.

Keywords: Brillouin scattering, Optical fiber sensors, Fiber ring lasers.

1 Introduction

Brillouin Ring Lasers (BRLs) are a fiber-based light source in which a light (defined as seed pump) is injected and circulates inside a closed fiber loop, where it produces a coherent, downshifted and counterpropagating light (defined as Stokes light) through a process known as stimulated Brillouin scattering (SBS) [1]. Due to their capability to provide a light signal which is coherent and with a stable frequency shift from the light it originated from with limited intensity and phase noise, BRLs have been studied for applications such as fiber-optics gyroscopes [2], microwave phase-modulated generators [3] and LIDAR detection. Another potentially interesting field of application is distributed optical fiber sensing, which has gathered significant attention in recent years due to the interesting properties of optical fibers, such as resistance and flexibility [4]. A particularly interesting distributed optical fiber sensing method is Brillouin optical time-domain analysis (BOTDA) [5–7]. In this sensing scheme, which is also based on SBS, an optical pump amplifies a downshifted, counter-propagating probe along a sensing fiber. The extent of this amplification is related to the pump-probe frequency shift with a relation known as the Brillouin gain spectrum (BGS), and the shift at which this amplification is most efficient is known as the Brillouin frequency shift (BFS) which is dependent on the temperature and strain of every point in the fiber [8]. The pump and probe lights are usually provided by sources such as phase locked loop (PLL) schemes or optical sideband

generation (OSB) techniques [9], which tend to have strict requirements in terms of laser source quality and hardware components. In this context, the natural frequency shift of BRLs and the simplicity of their structure makes them an interesting alternative for low-complexity BOTDA setups. In [10], an implementation of a BRL source based on a long cavity (2 km) hybrid BRL source was developed and successfully employed in a BOTDA sensing scheme, where it allowed for measurements over up to 10 km of range with a spatial resolution of 4 m and a frequency resolution of 0.5 MHz. While these results were already viable for some BOTDA applications, the BRL cavity was affected by three issues which limited its performance: low maximum output power, high output linewidth (2 MHz) and a high relative intensity noise (RIN) for frequencies below 1 GHz. Among the various possible noise effects, the most relevant one was found to be the mode hopping effect, which is schematically illustrated in Figure 1: the frequency of the output of a BRL cavity will be the resonant mode which is closest to the BFS of the fiber, which is known as the dominant mode. Thermal and acoustic vibrations in the ring continuously generate shifts either in the BFS or in the position of the resonant modes. When the dominant mode changes, the output frequency of the BRL rapidly changes alongside its intensity, significantly increasing noise. It was also hypothesized that this effect was more severe with longer BRLs, since the resonant mode spacing is inversely proportional with the cavity length.

In this work, a new BRL design is presented to overcome these limitations. Unlike the other design, this one is based on a short cavity (~ 4 m) Brillouin ring laser

* Corresponding author: bolognini@bo.imm.cnr.it

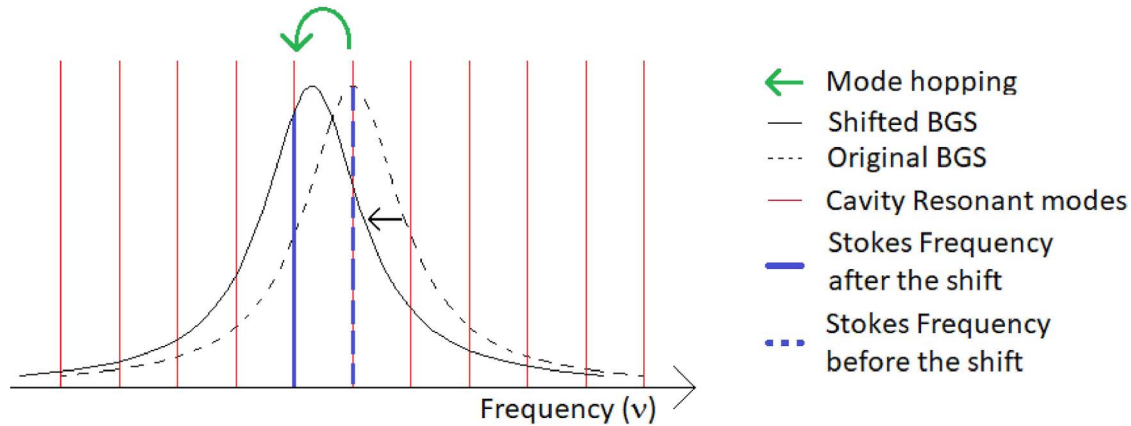

Fig. 1. Schematic representation of the mode hopping effect.

(SC-BRL) in order to suppress mode hopping and improve linewidth narrowing of the Stokes output. Through accurate tuning of the length of the cavity and self-injection locking techniques, the BRL was made resonant for both the seed pump and the Stokes output. Since the tunability can no longer be provided by a piezo actuator because the shift in the BFS would break double resonance, a wavelength-locking system was implemented to tune and further stabilize the frequency shift between seed pump and Stokes output through the use of a low bandwidth (<1 GHz) modulator.

As a result, the new source displayed significantly reduced RIN, greatly reduced linewidth of the Stokes light, higher maximum output power and a highly stable pump-probe frequency shift. While compared to the LC-BRL design this source system requires tuning of the cavity length alongside the addition of more electro-optical components, their requirements are still less strict than OSB. In addition, the narrowing qualities of the short cavity mean that the linewidth requirements for the seed pump DFB source can be reduced.

2 Short-cavity Brillouin ring laser

The BRL cavity that is studied in this work is shown in Figure 2. Through the exits 1 and 2 of an optical circulator (OC1), the seed pump light from a distributed feedback laser ($\lambda = 1555$ nm, 350 kHz linewidth) is injected inside the ring cavity which, at its core, is composed of a loop of standard single mode optical fiber for telecommunication (SMF-28) with a length below 5m. The loop is closed by a directional coupler (DC1) with a 90/10 coupling ratio. While re-circulating inside this cavity, the seed pump is scattered through SBS, producing a counter propagating downshifted Stokes light, a portion of which is extracted through DC1 and employed as output after going through exits 2 and 3 of OC1 to be employed in the sensing system. It is to note SBS is a process that is dependent on the seed pump and Stokes light relative states of polarization (SOP). In particular, SBS gain is maximum when the SOPs are parallel, and minimum when they are orthogonal [11].

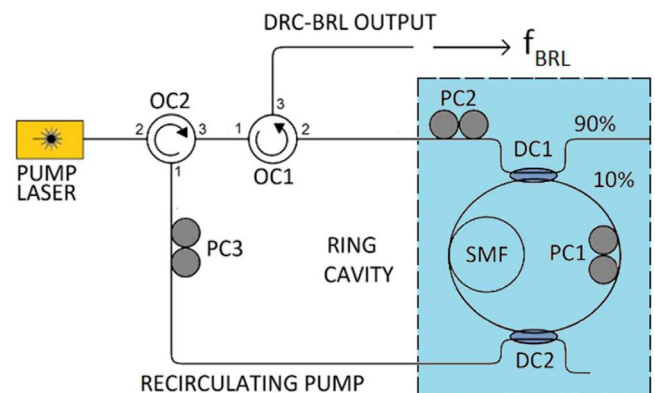

Fig. 2. Scheme of the short-cavity BRL with self-injection locking.

Generally speaking, the SOPs of light signals traveling along single-mode fibers are not preserved because of the effect of random birefringence. One way to solve this is to employ a polarization scrambler, but this has the side effect of limiting the maximum achievable SBS gain [12]. In our set-up, birefringence effects were less relevant due to the short length of the fiber inside the BRL. As a result, it was sufficient to employ two polarization controllers (PC1-2 in Fig. 1) and set them to maximize the intensity of the Stokes output.

Compared to [10], the length of the ring cavity was reduced from 2 km to 5 m. As was mentioned above, one of the sources for the high relative intensity noise of the previous cavity were mode-hopping effects. These effects are caused by the fact that the frequency at which a BRL emits light (the dominant frequency) is the cavity resonant mode which is closest to the BFS, and the positions of both these elements can shift due to thermal and vibrational noises. When this happens, a different resonant mode might become the one closest to the BFS, and thus the dominant mode might change. As a result, both frequency and intensity noise are increased as the BRL source “hops” from one mode to another [13]. This effect is more prevalent the lower the spacing between resonant frequencies is and conversely

can be suppressed by increasing the spacing of the resonant modes enough that only one mode lies inside the BGS at any point, hence the greatly reduced cavity length presented in this work. The simplest way to achieve this is by reducing the cavity length, which is inversely proportional to the resonant mode spacing, from 2 km down to a length below 5 m, like the one we present in this work.

To counteract the steep reduction in gain medium compared to cavities like the one shown in [10], the cavity is made resonant with both the seed pump and the Stokes output. When this condition, known as double resonance, is satisfied, both lightwaves interfere constructively with newly injected seed pump and newly generated Stokes light at every roundtrip, thus greatly increasing the effective interaction length and overall conversion efficiency. The resonance of the seed pump is guaranteed through the implementation of a self-injection locking technique [14] in the BRL scheme, which is included in Figure 1. An optical coupler with a 99/1 coupling ratio (DC2) extracts part of the seed pump inside the ring (which is at the resonant frequency) and sends it back into the DFB laser through exits 1 and 2 of a second optical circulator (OC2). As a result, the DFB is forced to emit at the frequency of the injected light, making the pump resonant with the cavity. While in principle one of the outputs of DC1 could be used for the same purpose, the low intensity required for self-injection locking made the addition of a coupler with a smaller ratio more desirable, while also allowing for simultaneous monitoring of both the Stokes light and the recirculating pump (through the free exits of DC2 and DC1, respectively). In order to make the Stokes light resonant with the cavity, its length is accurately tuned through the use of a single cut technique developed in [15] to calculate the length ΔL so that the BFS of the fiber is equal to an integer multiple of the resonant modes free spectral range, v_{FSR} , which is defined as:

$$v_{\text{FSR}} = \frac{c}{n} \cdot \frac{1}{L}, \quad (1)$$

where L is the cavity length, n is the fiber refractive index and c is the speed of light. Since the Brillouin frequency shift v_{SBS} can be calculated as:

$$v_{\text{SBS}} = \frac{2nV_s}{\lambda_{\text{sp}}}, \quad (2)$$

where V_s is the speed of sound inside the BRL cavity and λ_{sp} is the seed pump wavelength. The double resonance condition can thus be restated, for a given integer d :

$$v_{\text{SBS}} = d \cdot v_{\text{FSR}}, \quad (3)$$

which, given equations (1) and (2), becomes:

$$\frac{c}{n} \cdot \frac{1}{L} = d \cdot \frac{2nV_s}{\lambda_{\text{sp}}}, \quad (4)$$

which, solved for λ_{sp} , leads to the wavelength $\lambda_{\text{sp}}^{d,L}$ that satisfies the double resonant conditions for a given integer d and length L :

$$\lambda_{\text{sp}}^{d,L} = \frac{2n^2V_sL}{d \cdot c}. \quad (5)$$

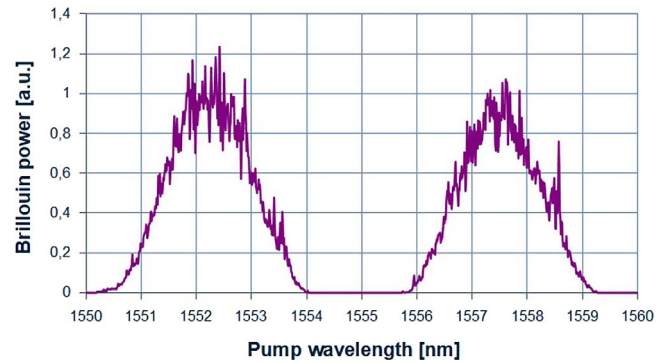

Fig. 3. Double resonance peaks for a cavity length of 5 m.

The single cut technique involves measuring the intensity of the Stokes output at different seed pump wavelengths using a tunable laser in place of the DFB, providing a measurement such as the example for a cavity of 5 m shown in Figure 3. The goal of this measurement is to locate two consecutive peaks corresponding to wavelengths for which double resonance is satisfied, $\lambda_{\text{sp}}^{d,L}$ and $\lambda_{\text{sp}}^{d-1,L}$. With these wavelength values and with (5), it is possible to determine d as:

$$d = \lambda_{\text{sp}}^{d,L} = \frac{\lambda_{\text{sp}}^{d-1,L}}{\lambda_{\text{sp}}^{d-1,L} - \lambda_{\text{sp}}^{d,L}}. \quad (6)$$

Once the index is known, it is possible to obtain L from (5) (which, due to the way BRLs are constructed, cannot be reliably determined *a priori*) as a function of $\lambda_{\text{sp}}^{d,L}$:

$$L = \frac{d \cdot c}{2n^2V_s} \lambda_{\text{sp}}^{d,L}. \quad (7)$$

Using (7), it is possible to calculate the length ΔL that has to be cut from the cavity to make sure that the double resonance peak of order d falls on the desired wavelength $\lambda_{\text{sp}}^{d,M}$ by applying (7) to one of the known peaks $\lambda_{\text{sp}}^{d,L}$ and $\lambda_{\text{sp}}^{k,M}$ and subtracting the two results:

$$\Delta L = \frac{c\lambda_{\text{sp}}^{d,L}}{2n^2V_s} \frac{1}{\lambda_{\text{sp}}^{d-1,L} - \lambda_{\text{sp}}^{d,L}} \left(\lambda_{\text{sp}}^{d,M} - \lambda_{\text{sp}}^{d,L} \right). \quad (8)$$

Given the speed of sound inside the fiber used to construct the BRL cavity, the measured peaks and the desired wavelength, after the process, the cavity was found to be around 3.4 m long.

3 Wavelength-locking stabilization system

To employ the SC-BRL design as a pump-probe source in BOTDA, it must be possible to change its frequency shift compared to the pump. In [10], this was achieved through the use of a piezoactuator which increased the BFS of the ring cavity by applying strain to it, thus changing the wavelength of the Stokes output. In this new design, doing so

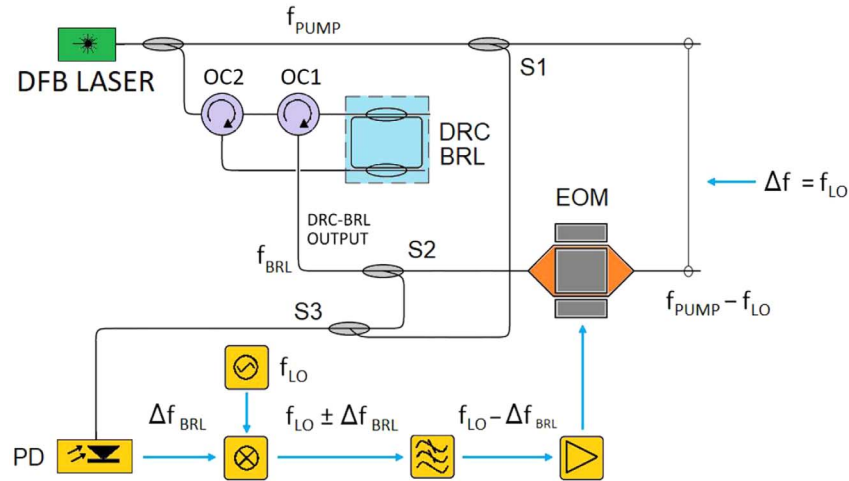

Fig. 4. Wavelength-locking stabilization scheme.

would break double resonance. To provide pump-probe frequency shift tuning for the SC-BRL design, a wavelength locking method such as the one shown in Figure 4 was implemented. A small fraction of the seed pump and the Stokes output from the doubly resonant BRL (DRC-BRL) are extracted through two optical couplers (S1 and S2) and mixed together into a third one (S3). Their resulting beating signal is fed into a fast photo-detector (PD), outputting an RF signal with frequency Δf_{BRL} equal to the frequency difference between the pump and the Stokes output $f_{\text{pump}} - f_{\text{BRL}}$. The RF signal is then mixed with a local oscillator at frequency f_{LO} , resulting in two sidebands at frequency $(f_{\text{LO}} \pm \Delta f_{\text{BRL}})$. Applying a low pass filter, the higher sideband is removed, and the remaining signal at $f_{\text{LO}} - \Delta f_{\text{BRL}}$ is amplified and is used to drive an electro-optical modulator (EOM) modulating the Stokes output.

The BRL output at frequency f_{BRL} is split into two sidebands, the upper one at frequency $f_{\text{USB}} = f_{\text{BRL}} + f_{\text{LO}} + \Delta f_{\text{BRL}}$ and the lower one at frequency $f_{\text{LSB}} = f_{\text{BRL}} + f_{\text{LO}} - \Delta f_{\text{BRL}} = f_{\text{PUMP}} - f_{\text{LO}}$, which is downshifted from the pump by a frequency *equal* to the one of the tunable local oscillator.

It can be also seen that outside of tunability, this system provides active compensation of the pump-probe frequency shift: if the Stokes output frequency drifts from f_{BRL} to $f_{\text{BRL}} + \delta f$, the detuning with the pump becomes $\Delta f_{\text{BRL}} - \delta f$ and the lower sideband of the modulated light becomes $f_{\text{LSB}} = f_{\text{BRL}} + \delta f - f_{\text{LO}} + \Delta f_{\text{BRL}} - \delta f = f_{\text{PUMP}} - f_{\text{LO}}$, compensating the original frequency drift.

One thing that must be taken into consideration is that, in order for the system to work, $f_{\text{LO}} - \Delta f_{\text{BRL}}$ must be greater than 0, and thus the seed pump-Stokes output frequency shift must always be lower than the pump-probe frequency shifts that will be used in BOTDA. As a consequence, the fiber composing the SC-BRL must have a BFS that is lower than the one of the sensing fiber can reach. In addition, it must be ensured that the upper sideband exiting the EOM with frequency $f_{\text{USB}} = f_{\text{BRL}} + f_{\text{LO}} - \Delta f_{\text{BRL}}$ is always outside the BGS of the sensing fiber and does not interfere with the sensing process.

The frequency difference between the two sidebands can be written as:

$$\begin{aligned} f_{\text{USB}} - f_{\text{LSB}} &= f_{\text{BRL}} + f_{\text{LO}} - \Delta f_{\text{BRL}} - f_{\text{PUMP}} + f_{\text{LO}} \\ &= 2(f_{\text{LO}} - \Delta f_{\text{BRL}}). \end{aligned} \quad (9)$$

It is immediate to see that in order to obtain a separation of at least 2 GHz, Δf_{BRL} must be 1 GHz lower than the minimum value f_{LO} will take. Assuming a standard telecom fiber is employed for sensing, the minimum f_{LO} will be 10 GHz, thus the SC-BRL should be constructed using a fiber with a BFS equal to around 9 GHz.

This has been done by changing the Germanium doping level of the fiber inside the BRL. It is a well known fact that higher Germanium concentrations lower the acoustic velocity of the core which is linked to the BFS by a relation of direct proportionality [16]. In this work, the BRL was composed by a fiber with Ge concentrations of 20%_{weight}, up from 3%_{weight} of standard optical fibers. As a result of this choice, the BFS of the fiber inside the BRL reached a value of 9 GHz, down from the ~10.86 GHz of standard fibers, ensuring that the upper sideband exiting from the modulator does not interact with the pump light.

While this system requires the use of an EOM, the frequency that drives it (equal to $f_{\text{LO}} - \Delta f_{\text{BRL}}$) can be small enough to be compatible with EOMs with a bandwidth of 1–2 GHz, while traditional BOTDA interrogating schemes such as the optical sideband method require EOMs with bandwidth of more than 10 GHz.

4 Performance evaluations

In order to see how this new design affected the issues noted from the source developed in [10], the Stokes output for this source was evaluated in terms of maximum power, linewidth and intensity noise.

The maximum Stokes output power was found to be 1.5 mW for a pump power of 25 mW, while the design

showcased in [10] was found to provide an output with a maximum power of 0.5 mW for a 17 mW pump. The lasing threshold power (the minimum pump power required to obtain Brillouin lasing from the BRL), on the other hand, was 10 mW, up from the 2 mW found in [10]. These results show that the double resonance effect allows to counteract the greatly reduced amount of gain medium, providing comparable lasing threshold power compared to a long cavity, while providing higher output power, which is a crucial parameter for improved measurement range.

Afterwards, the linewidth of the Stokes output was measured by acquiring the spectrum through the use of the self-heterodyne technique [17], performed with a Mach-Zehnder interferometer as the one shown in Figure 5 employing a 150 MHz acousto-optic modulator and a delay line with a length of 12 km which, when sent into an electrical spectrum analyzer (ESA), allows to measure signal spectra with minimum linewidths of 6 kHz [18].

As a result, the output spectrum, shown in Figure 6, was found to have a full width half-maximum of 10 kHz, showing a significant narrowing compared to the output of the long cavity BRL (2.5 MHz), and also significantly narrower than the linewidth of the DFB signal used as seed pump (350 kHz), showing the beneficial effect of a short cavity BRL's filtering capabilities.

It is a well-known fact that self-injection locking also reduces the linewidth of the DFB laser it is used on. To test the effect self-injection locking, alongside the resonant behavior of the BRL, the same measurement was performed on the recirculating pump being injected into the DFB. The result showed a similar narrowing effect, with a linewidth of 10 kHz, showing how self-injection locking allows for significant improvement of the signal quality despite the relative wide bandwidth of the original source, further easing up the hardware requirements of the system.

To evaluate how self injection locking improves lasing stability in BRL, the durations of Stokes lasing intervals with and without self-injection locking were measured with a photo-detector and an oscilloscope. The results are shown in Figure 7. Without self-injection locking, the duration of Brillouin lasing was found to be between 2 and 10 ms, while with self-injection locking the duration was significantly increased with values ranging from 30 to 90 ms, which is already sufficient for BOTDA measurements. The reason for this difference is of course linked to the seed pump light remaining resonant with the cavity for a much longer time despite thermal and vibrational noise.

As a further test on the effect of self-injection locking on overall sensing performance, two laser sources with two different linewidths, an external cavity laser (ECL) (Emcore 1792, 37 kHz linewidth) and a DFB (FLD5F6CX-J, 310 kHz linewidth) were used as seed pump on a DR-SC BRL cavity with a length of 19 m, and their lasing stability was compared. Both sources were fed with a current of 40 mA, resulting in Stokes output powers of -1.1 dBm for the ECL and -0.9 dBm for the DFB. The results are shown in Figure 8: with the narrow linewidth ECL as seed pump (Fig. 8a), lasing period of a length between 1 and 100 ms were recorded, while with the wide linewidth DFB (Fig. 8b) lasing periods between 5 and 500 ms were

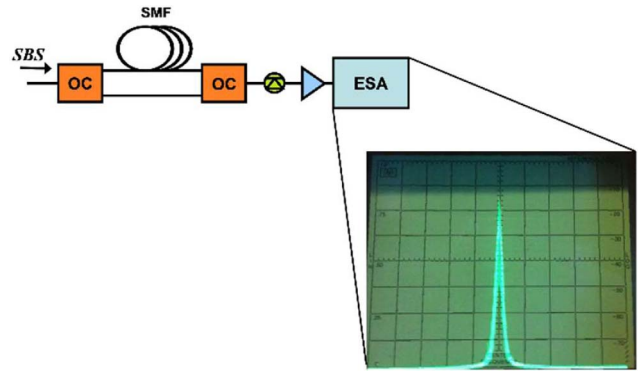

Fig. 5. Self-heterodyne detection method.

achieved. Generally speaking, without self injection locking the lasing stability of a high-finesse ring cavity is expected to benefit from a narrow seed pump linewidth of the pump laser. However, with self-injection locking stabilization the pump laser already experiences a narrowing effect, and a wider linewidth might actually improve lasing stability by allowing the source to track greater shifts in the recirculating pump frequency.

To evaluate the combined effect of the wavelength-locking system, self-injection locking and mode hopping suppression on the pump-probe frequency shift stability, the output of the DFB pump and the Stokes output were coupled into the same fiber tract and sent into a 12 GHz photodetector, which acquired their beating signal, which in turn was analyzed with an ESA. The spectrum obtained was a peak centered at the frequency shift between the two lightwaves, and a linewidth that is linked with the frequency drift over the averaging time chosen for the measurement. For the wavelength-locking system to work properly, the peak should be at a frequency equal or at least as close as possible to the chosen local oscillator frequency f_{LO} , and a linewidth as narrow as possible. Results of this evaluation are shown for a f_{LO} value of 10.86 GHz in Figure 9, for averaging times of 10 ms (Fig. 9a), which corresponds to the timescale of a single BOTDA measurement, and an extended period of 120 s (Fig. 9b). In both cases the peak is within 1 kHz of f_{LO} (which is chosen as the center of the quadrants), indicative of a high accuracy of the tunability. In addition, the linewidth of the two peaks was 200 Hz for 10 ms and 400 Hz for 120 s averaging time, showing very high stability for BOTDA application, considering that measuring steps are of the order of MHz. Similar measurements were performed with f_{LO} values ranging from 10.7 to 11.5 GHz (the range allowed by the local oscillators), proving that the SC-BRL alongside the wavelength-locking system are capable of providing pump and probe lights with frequency shifts that are accurately tunable and extremely stable for timescales well above the ones required by single measurements.

Finally, in order to evaluate how the employment of a short cavity suppresses noise effects such as mode hopping, RIN measurements were performed in a way similar to [10], as shown in Figure 10. These measurements were performed

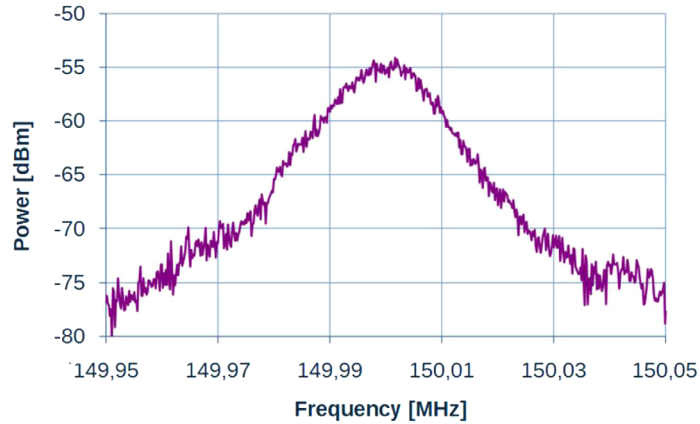

Fig. 6. Short cavity BRL output spectrum.

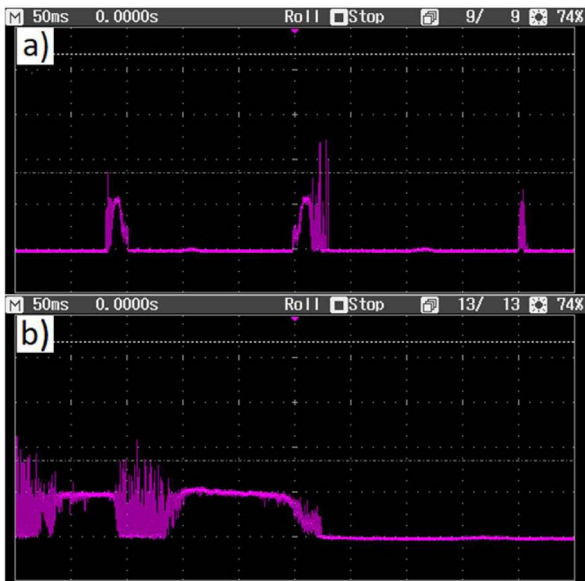

Fig. 7. Stokes output trace without self-injection (a) and with self-injection (b). Timescale: 50 ms per division.

by acquiring the BRL Stokes output light with a fast p-i-n photodetector (InGaAs-based, 10 GHz bandwidth) to convert a light signal into a voltage signal, whose power spectrum $\sigma^2(\omega)$ in the 1–800 MHz range was analysed through an ESA (working up to 15 GHz) after subtracting thermal and shot noise terms due to the photodetector [19]. As is evident from the image, the RIN profile of the SC-BRL ranges between -140 dB/Hz and -150 dB/Hz across the whole 0–800 MHz range, adding a limited amount of intensity noise to the profile of the source DFB. The long-cavity BRL (> 2 km length) developed in [10], on the other hand, introduces significant intensity noise, increasing the RIN profile at frequencies below 400 MHz, with values up to -90 dB/Hz in the 10–15 MHz frequency range, and becomes similar to the DFB seed pump only beyond 500 MHz, where it remains approximately constant with an average value of about -145 dB/Hz. From these results it can be easily seen how the reduction of cavity length,

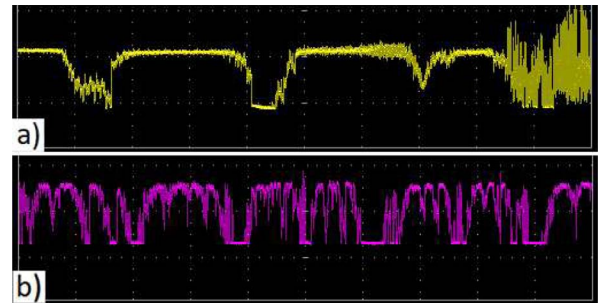

Fig. 8. Stokes output trace with self-injection and the 37 kHz ECL source as seed pump (200 ms/div timescale) (a) and the 310 kHz dBm source as seed pump (500 ms/div) (b).

mixed with the contribution of self-injection locking suppress noise sources and instability usually associated with fiber cavities that increase the RIN profile of the output compared to the source pump seed [20].

It can be shown that the reduction in intensity noise provided by the stabilization from self-injection locking and the mode hopping suppression from the employment of the short cavity directly impact BOTDA resolution. To show this, the intensity noise limited signal-to-noise ratio (SNR) for both the SC-BRL source and the long-cavity one was calculated by integrating their RIN spectra over a frequency range equal to the bandwidth of a typical photodiode used in BOTDA (125 MHz). The resulting values were 38.7 dB for the long cavity BRL and 61.0 dB for the short cavity one, which implies a SNR improvement of 22 dB. When Lorentzian Curve fitting is used to extract the BFS in BOTDA measurements, source SNR can be translated to frequency resolution $\delta\nu_B$ with the following relation [21]:

$$\delta\nu_B = \frac{\Delta\nu_B}{\sqrt{2}(\text{SNR})^{\frac{1}{4}}} \quad (10)$$

where $\Delta\nu_B$ is the linewidth of the Brillouin gain spectrum.

Due to the linear dependency between the BFS and temperature and strain, their resolutions are also directly

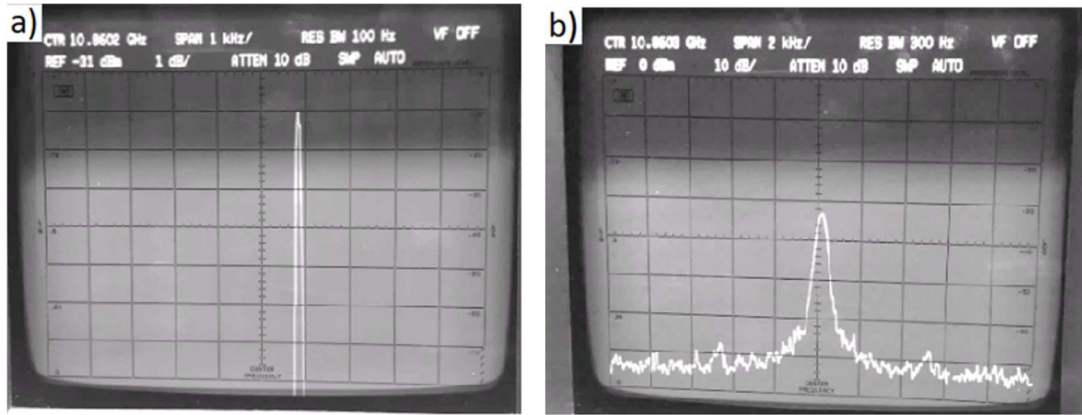

Fig. 9. Electrical spectrum of the pump-probe beating for wavelength locked DRC-BRL for averaging times of 10 ms (a) and 120 s (b). The frequency range is centered at the local oscillator frequencies f_{LO} 10.8602 GHz and 10.8608 respectively. The y axis scale is 1 dB/division (a) and 10 dB/division (b), while the x axis scale is 1 kHz/division (a) and 2 kHz/division (b).

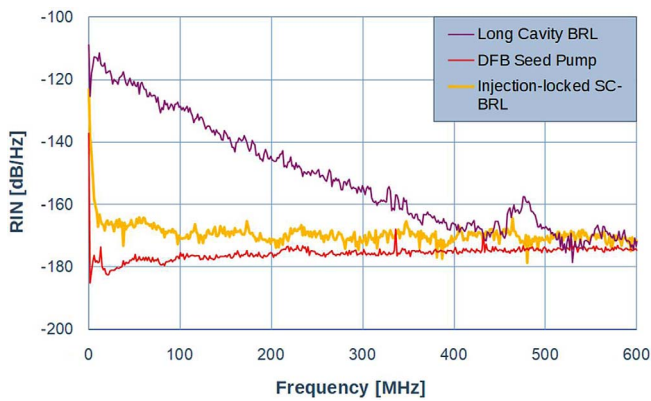

Fig. 10. Comparison of the RIN profiles of the sources.

proportional to the frequency resolution, and they can be calculated as:

$$\delta\varepsilon = \frac{\delta v_B}{C_S v_B(0)} \quad \text{and} \quad \delta T = \frac{\delta v_T}{C_T v_B(t_r)} \quad (11)$$

where $v_B(0)$ and $v_B(t_r)$ are the Brillouin frequency shifts of unstrained sensing fiber and of sensing fiber at reference temperature, respectively, while C_S and C_T are the linear temperature and strain coefficients.

From the relations above is immediate to see that, for sources whose SNR is limited by intensity noise, such as BRLs, a 22 dB improvement is equivalent to a resolution improvement of 5.5 dB which, converted in linear scale, is equal to an improvement in frequency, strain and temperature resolutions by a factor of ~ 3.5 .

5 Summary and conclusions

In this work, the development and characterization of a Brillouin Ring Laser based on a doubly resonant short cavity to be employed as a source for Brillouin optical time

domain analysis were showcased and discussed, alongside a wavelength-locking system to accurately tune and stabilize the pump-probe frequency shift. Compared to previously developed designs, which used long (>2 km) cavities, the employment of a short cavity was expected to provide substantial improvements in terms of output linewidth and intensity noise, due to the positive correlation between mode hopping effects and cavity length. Double resonance, which was achieved through the combined effect of a self-injection locking approach and the use of a single cut technique, was expected to allow for the cavity length to be reduced down to a few meters without significant losses in threshold seed pump power and maximum output. Experimental evaluation showed that the new cavity had a threshold seed pump power of 10 mW, up from the 2 mW found in previous design, while having a maximum output power of 1.5 mW, up from 0.5 mW, showing how the single cut technique allowed for a threshold power of the same order of magnitude despite the great reduction of gain medium, while providing an even greater maximum output power. In terms of output linewidth, the short cavity and self-injection locking were found to allow for a Stokes output with an extremely narrow linewidth of 10 kHz from an original source of 350 kHz, down from the 2 MHz linewidth found for long cavity Brillouin Ring Lasers. These combined narrowing effects were found to provide similar benefits to the pump light as well, whose linewidth was found to be narrowed to 10 kHz as well.

In addition to linewidth narrowing, self-injection locking was found to significantly improve lasing stability, allowing for lasing intervals of up to 90 ms, compared to the 10 ms ones obtainable without it. Testing seed pump sources with different linewidths in a 19 m long cavity, it was also found that a narrow linewidth source did not provide any substantial improvement to lasing stability, with a 37 kHz ECL source, achieving lasing intervals which were similar if not shorter than the ones obtained with a 310 kHz DFB source. These results indicate that self-injection locking and short cavities might be crucial factors in easing the hardware requirements for BOTDA pump sources, thus potentially contributing to increasing its field of applicability.

The wavelength-locking system, in addition, was found to provide a frequency shift between the Stokes output and the seed pump which was tunable with sub-kHz accuracy over a range of more than 800 MHz and with high temperature stability, with shifts of the order of 200 Hz over 10 ms timeframes and 400 Hz over 120 s timeframes.

Finally, the intensity noise improvements provided by a short cavity, were evaluated through RIN measurements, obtaining values of ~ -145 dB/Hz across the whole 0–800 MHz range, which were compared to RIN measurements performed on previous long cavity designs, which reached significantly higher values, up to -90 dB/Hz. Compared to the long cavity, the RIN improvements are shown to translate to a BOTDA strain and temperature resolution improvement by up to a factor of 3.5.

From these results it can be seen how the stabilized doubly resonant BRL design can provide substantial improvements in a variety of applications. For what concerns BOTDA, it has the potential to be successfully employed as a pump-probe source in accurate Brillouin optical time-domain sensor systems.

Conflict of interest

The authors declare no conflict of interest.

Acknowledgments. This activity has received funding from the European Union through Horizon 2020, the Framework Programme for Research and Innovation, under project SLAM-DAST, Grant Agreement No. 971149.

References

- 1 Preda C.E., Fotiadi A.A., Mégret P. (2012) Numerical approximation for Brillouin fiber ring resonator. *Opt. Express* **20**, 5783–5788.
- 2 Smith S.P., Zarinetchi F., Ezekiel S. (1991) Narrow-line-width stimulated Brillouin fiber laser and applications, *Opt. Lett.* **16**, 393–395.
- 3 Nicati P.A., Toyama K., Huang S., Shaw H.J. (1994) Frequency pulling in a Brillouin fiber ring laser, *IEEE Photonics Technol. Lett.* **6**, 801–803.
- 4 Soto M.A., Sahu P.K., Faralli S., Sacchi G., Bolognini G., Di Pasquale F., Nebendahl B., Rueck C. (2007) High performance and highly reliable Raman-based distributed temperature sensors based on correlation-coded OTDR and multimode graded-index fibers, *Proc. SPIE* **66193B**, 532–535.
- 5 Marini D., Rossi L., Bastianini F., Bolognini G. (2018) Study of enhanced performance fiber Brillouin ring laser with wavelength-locking for sensing applications, in: 20th Italian National Conference on Photonic Technologies (Fotonica 2018), IET Conference Publications, CP748.
- 6 Marini D., Rossi L., Bastianini F., Bolognini G. (2018) Enhanced-performance fibre Brillouin ring laser for Brillouin sensing applications, *OSA Techn. Digest Part F124-OFS*, ThE71.
- 7 Rossi L., Marini D., Bastianini F., Bolognini G. (2019) Analysis of enhanced-performance fibre Brillouin ring laser for Brillouin sensing applications, *Opt. Express* **27**, 29448–29460.
- 8 Falcetelli F., Rossi L., Di Sante R., Bolognini G. (2020) Strain transfer in surface-bonded optical fiber sensors, *Sensors* **20**, 3100.
- 9 Nikles M., Thévenaz L., Robert P.A. (1996) Simple distributed fiber sensor based on Brillouin gain spectrum analysis, *Opt. Lett.* **21**, 758–760.
- 10 Marini D., Iuliano M., Bastianini F., Bolognini G. (2018) BOTDA sensing employing a modified Brillouin fiber laser probe source, *J. Light. Technol.* **36**, 1131–1137.
- 11 Galtarossa A., Palmieri L., Pizzinat A., Marks B.S., Menyuk C.R. (2003) An analytical formula for the mean differential group delay of randomly birefringent spun fibers, *J. Light. Technol.* **21**, 1635–1643.
- 12 Galtarossa A., Palmieri L., Santagiustina M., Schenato L., Ursini L. (2008) Polarized Brillouin amplification in randomly birefringent and unidirectionally spun fibers, *IEEE Photonics Technol. Lett.* **20**, 1420–1422.
- 13 Nicati P., Toyama K., Shaw H.J. (1995) Frequency stability of a Brillouin fiber ring laser, *J. Light. Technol.* **13**, 1445–1451.
- 14 Bueno Escobedo J.L., Spirin V.V., López-Mercado C.A., Mégret P., Zolotovskiy I.O., Fotiadi A.A. (2016) Self-injection locking of the DFB laser through an external ring fiber cavity: Polarization behavior, *Results Phys.* **6**, 59–60.
- 15 Spirin V.V., López-Mercado C.A., Kablukov S.I., Zlobina E. A., Zolotovskiy I.O., Mégret P., Fotiadi A.A. (2013) Single cut technique for adjustment of doubly resonant Brillouin laser cavities, *Opt. Lett.* **38**, 2528–2530.
- 16 Nickles M., Thevenaz L., Robert P.A. (1997) Brillouin gain spectrum characterization in single mode optical fibers, *IEEE J. of Lightwave Technology* **15**, 10, 1842–1851.
- 17 Horak P., Loh W.H. (2006) On the delayed self-heterodyne interferometric technique for determining the linewidth of fiber lasers, *Opt. Exp.* **14**, 3923–3928.
- 18 Derickson D. (1998) *Fiber optic test and measurement*, Prentice Hall.
- 19 Bolognini G., Faralli S., Chiuchiarelli A., Falconi F., Di Pasquale F. (2006) High-power and low-RIN lasers for advanced first-and higher order Raman copumping, *IEEE Photonics Technol. Lett.* **18**, 1591–1593.
- 20 Ou Z., Bao X., Li Y., Saxena B., Chen L. (2014) Ultranarrow linewidth Brillouin fiber laser, *IEEE Photonic. Tech. L.* **26**, 2058–2061.
- 21 Soto M.A., Bolognini G., Di Pasquale F. (2010) Analysis of pulse modulation format in coded BOTDA sensors, *Opt. Exp.* **18**, 14878–14892.