



Title	Oxidative removal of soluble divalent manganese ion by chlorine in the presence of superfine powdered activated carbon
Author(s)	Saito, Shun; Matsui, Yoshihiko; Yamamoto, Yasuhiko; Matsushita, Shuhei; Mima, Satoru; Shirasaki, Nobutaka; Matsushita, Taku
Citation	Water research, 187, 116412 https://doi.org/10.1016/j.watres.2020.116412
Issue Date	2020-12-15
Doc URL	http://hdl.handle.net/2115/87517
Rights	© 2020. This manuscript version is made available under the CC-BY-NC-ND 4.0 license http://creativecommons.org/licenses/by-nc-nd/4.0/
Rights(URL)	http://creativecommons.org/licenses/by-nc-nd/4.0/
Type	article (author version)
File Information	Oxidative removal of soluble Mn_ver5.3ym all.pdf



[Instructions for use](#)

1
2
3
4
5
6
7
8
9
10
11
12
13
14
15
16

**Oxidative removal of soluble divalent manganese ion by chlorine
in the presence of superfine powdered activated carbon**

Shun Saito ^{a,b}, Yoshihiko Matsui ^{c*}, Yasuhiko Yamamoto ^b, Shuhei Matsushita ^d, Satoru Mima ^b, Nobutaka Shirasaki ^c, and Taku Matsushita ^c

^a Graduate School of Engineering, Hokkaido University, N13W8, Sapporo 060-8628, Japan

^b METAWATER Co., Ltd., Kandasuda-cho 1-25, Chiyoda-ku, Tokyo 101-8554, Japan

^c Faculty of Engineering, Hokkaido University, N13W8, Sapporo 060-8628, Japan

^d School of Engineering, Hokkaido University, N13W8, Sapporo 060-8628, Japan

* Corresponding author. Tel./fax: +81-11-706-7280

E-mail address: matsui@eng.hokudai.ac.jp

17
18
19
20

Research Highlights

- 21 • Superfine activated carbon and Cl_2 remove Mn(II) fast enough for practical purposes.
- 22 • Mn(II) is oxidized and precipitated on activated carbon in the presence of chlorine.
- 23 • External-film mass transfer is the rate-determining step of oxidative Mn(II) removal.
- 24 • The rate of Mn(II) removal follows pseudo-first-order reaction kinetics.
- 25 • Rate coefficient is in inverse proportion to as-is particle size of activated carbon.

26
27
28
29
30
31

Graphical Abstract

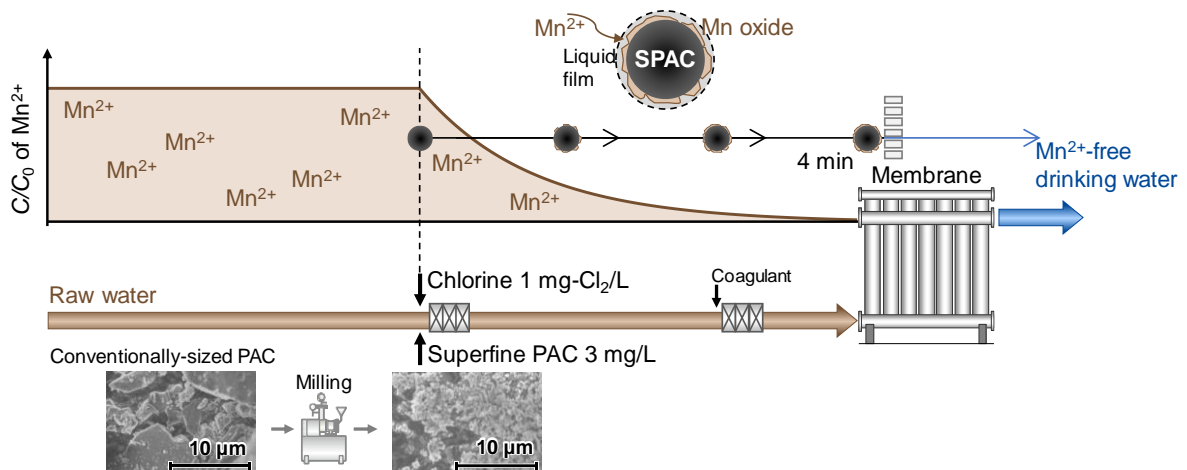

32

33 **Abstract**

34 Here, we examined the removal of soluble divalent manganese (Mn(II)) by combination
35 treatment with superfine powdered activated carbon (SPAC) and free chlorine in a membrane
36 filtration pilot plant and batch experiments. Removal rates >95 % were obtained with 3 mg/L
37 SPAC, 1 mg/L chlorine, and a contact time of 4 min, meeting practical performance standards.
38 Mn(II) was found to be oxidized and precipitated on the surface of the activated carbon particles
39 by chlorine. The Mn(II) removal rate was fitted to pseudo-first-order reaction kinetics, and the
40 rate coefficient changed in inverse proportion to as-is particle size, but not to true particle size.
41 The rate coefficient was independent of both Mn(II) concentration, except at high Mn(II)
42 concentration, and the chlorine concentrations tested. The rate-determining step of Mn(II)
43 removal was confirmed to be external-film mass transfer, not chemical oxidation. Activated
44 carbon was found to have a catalytic effect on the oxidation of Mn(II), but the effect was
45 minimal for conventionally sized activated carbon. However, Mn(II) removal at feasible rates
46 for practical application can be expected when the activated carbon particle diameter is reduced
47 to several micrometers. Activated carbon with a particle size of around 1-2 μm may be the most
48 appropriate for Mn(II) removal because particles below this size were aggregated, resulting in
49 reduced removal efficiency.

50

51 **Keywords**

52 SPAC; catalysis; manganese; reaction kinetics; precipitation

53

54

55 **1. Introduction**

56

57 Several processes can be used to remove soluble divalent manganese (Mn(II)) in drinking
58 water treatments. These include 1) oxidation of Mn(II) to an insoluble form by using strong
59 oxidants, such as ozone, potassium permanganate, or chlorine dioxide, followed by solid–liquid
60 separation (Carlson et al., 1997; Gregory and Carlson, 2003); 2) adsorption and catalytic
61 oxidation on the surface of a metal oxide in the presence of free chlorine (Islam et al., 2010;
62 Knocke et al., 1991; Merkle et al., 1996); 3) ion-exchange/adsorption (Taffarel and Rubio,
63 2009); 4) nanofiltration or reverse osmosis membrane filtration (Tobiason et al., 2016), and 5)
64 microbial oxidation (Cerrato et al., 2010; Hoyland et al., 2014). Of these processes, adsorption
65 and catalytic oxidation by using Mn oxide (MnOx)-coated media in the presence of free
66 chlorine is often used because of its low cost, ease of operation, and stable removal efficiency
67 (Singer and Reckhow, 2011). In this approach, Mn(II) is adsorbed on the surface of the MnOx,
68 where it is catalytically oxidized by the free chlorine to produce new MnOx for subsequent
69 Mn(II) removal (Knocke et al., 1991; Merkle et al., 1997). In a conventional water purification
70 system composed of coagulation, flocculation, sedimentation, and media filtration processes,
71 the filter media can be coated with MnOx, which allows for simultaneous removal of Mn(II)
72 and suspended particles.

73 The use of microfiltration (MF) and ultrafiltration (UF) membrane filtration, which are
74 solid–liquid separation processes for the removal of suspended matter from water, has increased
75 in the past three decades, but these processes cannot remove Mn(II). To address this issue, a
76 pre-ozonation process or a MnOx-coated media contactor with free chlorine can be added to
77 the treatment process to oxidize and precipitate Mn(II). However, pre-ozonation has two
78 problems: residual ozone may damage the membrane, and soluble hexavalent Mn, which cannot
79 be removed by MF and UF, may be produced if ozone is added in excess. This means that in

80 practice a MnO_x-coated media contactor is most often used because it uses the same chemical
81 (chlorine) as used for disinfection, and, unlike ozone, chlorine does not produce soluble
82 hexavalent Mn when added in excess.

83 However, setting up a contactor only for Mn(II) removal is not economical when the raw
84 water contains Mn(II) at concentrations that do not have negative effects on health; that is,
85 concentrations that are lower than the health-based maximum value (0.4 mg/L) presented by
86 the World Health Organization (2017) but higher than the acceptable levels set for treated water
87 (0.02 mg/L [Health Canada, 2019] and 0.05 mg/L [MHLWJ, 2002; USEPA, 2004]). It has also
88 been reported that the accumulation of MnO_x in distribution pipes and its release can result in
89 stains forming on objects that the water comes into contact with and that these issues can occur
90 at Mn(II) concentrations as low as 0.02 mg/L (Sly et al., 1990) and 0.01 mg/L (Li et al., 2019b).
91 Therefore, water supply utilities usually set their own treatment targets for Mn(II) concentration.
92 In Japan, many regional water supply utilities use a treatment target of ≤ 0.001 mg/L (for
93 example, Kushiro City Water Supply and Sewerage Department, 2014; Moriwaki and Sakurai,
94 2012; Noboribetsu City Urban Development Department, 2019), which is much lower than the
95 national limit of 0.05 mg/L, to prevent staining problems. Under these circumstances, a low-
96 cost method for the removal of Mn(II) is desired.

97 Recently, Li et al. (2019a) reported that a commercially available powdered activated
98 carbon (PAC) catalyzed Mn(II) oxidation in the presence of free chlorine and increased the
99 oxidation rate by two orders of magnitude at a PAC dose as low as 5 mg/L compared with
100 oxidation by free chlorine alone. Previous studies had reported the adsorption of Mn(II) on
101 activated carbon, but the reported adsorption capacities were insufficient for practical
102 application (Mohan and Chander, 2001; Savova et al., 2003). Indeed, Li et al. (2019a) were able
103 to obtain only 95 % removal of Mn(II) in tens of minutes with a carbon dosage of 5 mg/L,
104 which is attractive but must be improved before a truly economical water treatment process can

105 be realized. Independent of the work of Li et al. (2019a), we discovered recently in a membrane
106 filtration pilot plant experiment that Mn(II) was removed by superfine powdered activated
107 carbon (SPAC) in the presence of free chlorine, and that the Mn(II) removal rate was high
108 enough for practical application of this approach as a water treatment process. This is an
109 interesting discovery, not only scientifically but also practically, as traditional approaches to
110 drinking water treatment have avoided the simultaneous use of activated carbon and chlorine
111 due to chlorine consumption and carbon oxidation (Crittenden et al., 2012; Gillogly et al., 1998;
112 Ohno et al., 2008; Snoeyink and Suidan, 1975; Summers et al., 2011). It might be easy to
113 imagine that the large specific surface area of SPAC, which is produced by micro-milling of
114 conventionally sized PAC [a median diameter (D50): tens of micrometers] and composed of
115 particles with D50 of no larger than a few micrometers (Ando et al., 2010; He et al., 2020;
116 Matsui et al., 2011; Pan et al., 2016), contributes to the high removability of manganese. In
117 order to clarify this phenomenon as a science-based technology, however, an in-depth analysis
118 of the high removability needs to be conducted.

119 SPAC is already being used as a novel adsorbent in five water treatment plants in Japan
120 because of its high adsorption capacity and faster adsorption kinetics compared with PAC, but
121 here we discuss the discovery of a new utilization of SPAC in water treatment processes. We
122 first describe the Mn(II) removal by SPAC in the presence of free chlorine that we observed in
123 our membrane filtration pilot plant experiment. We discuss the removal kinetics based on
124 experimental data obtained from batch experiments.

125

126

127 **2. Materials and Methods**

128

129 *2.1. Activated carbons*

130 Two commercially available wood-based PACs were obtained and designated PAC-P (PL-
131 WPS; Dainen Co., Ltd., Hyogo, Japan) and PAC-T (Taiko W; Futamura Chemical Co., Ltd.,
132 Nagoya, Japan). SPAC and submicron SPAC (SSPAC) were produced by milling each PAC in
133 wet-mill systems. PAC-P was milled to SPAC-P by using a one-pass beads mill (NVM-1.5;
134 Aimex Co., Ltd., Tokyo, Japan), and then stored as a slurry at the site of the membrane filtration
135 pilot plant experiments. PAC-T was milled to SPACs and SSPACs of different particle sizes
136 (SPAC-T₁₋₅ and SSPAC-T₁₋₃) by using a closed chamber ball mill followed by a recirculating
137 beads mill (LMZ015; Ashizawa Finetech Ltd., Chiba, Japan). The SPACs and SSPACs
138 produced from the PAC-T were stored as a slurry made with pure water (1–2 % w/v) at 4 °C
139 after vacuum conditioning to remove air from the pores of the activated carbons.

140 The true particle size distributions of the activated carbons were determined by means of a
141 laser-light diffraction and scattering method (Microtrac MT3300EXII; MicrotracBEL Corp.,
142 Osaka, Japan) after the addition of a dispersant (Triton X-100; Kanto Chemical Co., Tokyo,
143 Japan; final concentration, 0.08 % w/v) followed by ultrasonic dispersion. The as-is particle
144 size distributions of the activated carbons were determined by the same method but without the
145 dispersant and ultrasonic dispersion. The carbon particle concentrations at the time of
146 measurement in the Microtrac were from 5–50 mg/L. Table 1 shows the D50 values of the true
147 particle size distributions of the activated carbons.

148

149 *2.2. Membrane filtration pilot plant experiment*

150

151 *2.2.1. Membrane filtration pilot plant system*

152 The experiments were conducted at the membrane filtration pilot plant located at the
153 Shiraikawa Water Purification Plant of the Sapporo Waterworks Bureau, Japan (Fig. 1). The
154 pilot plant had two lines. Line A consisted of in-line coagulation and membrane filtration.

155 Coagulation was performed for a hydraulic retention time of 5 s in the pipe mixing. Line B
156 consisted of SPAC dosing, pre-chlorination, coagulation, and membrane filtration. SPAC and
157 chlorine were dosed to the raw water at almost the same point along the line, which was at a
158 hydraulic retention time of approximately 1 min prior to the point of coagulant dosing. The
159 hydraulic retention time for the coagulation in the pipe mixing of Line B was 3 min. Poly-
160 aluminum chloride (basicity 50 %; Hokkaido Soda Co. Ltd, Tomakomai, Japan), SPAC-P, and
161 NaOCl were used as the coagulant, SPAC, and chlorine, respectively.

162 The membrane module of Line A housed a ceramic monolith membrane element with full-
163 scale plant specifications (nominal pore size, 0.1 μm ; filtration area, 24 m^2 ; membrane diameter,
164 180 mm; membrane length 1500 mm; Metawater Co., Ltd., Tokyo, Japan), whereas that of Line
165 B housed a membrane element for small-scale experiments (nominal pore size, 0.1 μm ;
166 filtration area, 0.4 m^2 ; membrane diameter, 30 mm; membrane length 1000 mm). Both
167 membrane modules were operated in dead-end mode at a constant flow rate of 4.0 m/d (167
168 $\text{L}/(\text{m}^2 \text{ h})$) under positive pressure. Hydraulic backwash was conducted every 3.0 h at 500 kPa
169 using filtrate water from the permeate side. Each backwash was followed by a 150-kPa air-
170 blow from the feed-water side to remove the suspension inside the module.

171 Solution pH before filtration and residual free chlorine concentration in the filtrate were
172 monitored and kept constant (pH 6.8 and 0.2 $\text{mg-Cl}_2/\text{L}$, respectively) by automated-dosing of
173 H_2SO_4 and NaOCl with a feedback control system, and the data were stored continuously.
174 During the experiments, samples of the raw water and Line A and B filtrates were periodically
175 collected and analyzed for Mn(II) concentration.

176

177 2.2.2. Raw water quality

178 The pilot plant was used to treat the raw water used by the Shiraikawa Water Purification
179 Plant, which is taken from the Toyohira River. The total organic carbon (TOC) concentration

180 in the raw water was determined by a combustion catalytic oxidation method (TOC-L
181 CPH/CPN; Shimadzu Co., Kyoto, Japan). The concentrations of Mn(II) and aluminum were
182 determined by inductively coupled plasma mass spectrometry (ICP-MS; HP-7800; Agilent
183 Technologies, Inc., CA, USA). Ultraviolet absorbance at 260 nm (UV260) was determined by
184 using an ultraviolet and visible spectrophotometer (U-1900; Hitachi High-Tech Science
185 Corporation, Tokyo, Japan). Raw water samples were filtered through filter paper (No. 5C;
186 Toyo Roshi Kaisha, Ltd., Tokyo, Japan) prior to ICP-MS analysis and through a cellulose
187 acetate membrane filter with a nominal pore size of 0.45 μm (DISMIC 25CS045AN; Toyo
188 Roshi Kaisha) prior to UV260 analysis. The characteristics of the raw water are listed in Table
189 2.

190

191 2.3. *Batch experiments*

192 A stock solution containing 200 mg/L of Mn(II) was prepared by dissolving $\text{MnCl}_2 \cdot 4\text{H}_2\text{O}$
193 (Guaranteed Reagent; FUJIFILM Wako Pure Chemical Corporation, Osaka, Japan) in 0.1
194 mol/L HCl solution prepared from pure water (Milli-Q Advantage A10; Merck KGaA,
195 Darmstadt, Germany). The low acidity kept the Mn(II) in a soluble form. Prior to the Mn(II)
196 removal experiments, a beaker (4-L capacity, made from transparent polyvinyl chloride) and a
197 floating magnetic stirrer (Nalgene Suspended Magnetic Stir Bar; Thermo Fisher Scientific Inc.,
198 Massachusetts, USA) were soaked in a tank filled with 5 % v/v nitric acid to dissolve and
199 remove any metal residual. The floating magnetic stirrer was used to prevent the activated
200 carbon particles from rubbing the bottom of the beaker, which could reduce the particle size.

201 In the batch experiments, 2000 mL of pure water containing 0.4 mmol of carbonate buffer
202 (NaHCO_3) was spiked with the Mn stock solution at 10, 50, or 500 $\mu\text{g/L}$ with stirring at 400
203 rpm. After adjusting the pH to 7.0–7.1 by using HCl and NaOH solutions, one of the PACs,
204 SPACs, or SSPACs was added to the beaker at 1.0 mg/L. Control experiments without activated

205 carbon or chlorine were also conducted. After mixing for 5 min, NaOCl solution was added at
206 0.2, 0.3, 1.0, or 2.0 mg-Cl₂/L, and the resulting suspension was mixed for a further 15 min.
207 During mixing, the pH was monitored with a pH meter (HM-20P; DKK-TOA Corporation,
208 Tokyo, Japan) and adjusted to 7.0–7.1 (unless otherwise noted) by the addition of HCl or NaOH
209 solution as needed. Periodically, samples (40 mL) of the mixture were withdrawn, filtered
210 through a hydrophilic polytetrafluoroethylene membrane filter with a nominal pore size of 0.2
211 μm (DISMIC 25HP020AN, Toyo Roshi Kaisha), and the concentrations of soluble manganese
212 and free chlorine were measured by ICP-MS (HP-7700; Agilent Technologies) and the *N,N*-
213 diethyl-*p*-phenylenediamine colorimetric method (DR 900; Hach Co., Colorado, USA),
214 respectively. Residual chlorine concentration was determined to the value obtained by adding
215 0.01 mg/L to the measured value because the filtration decreased slightly the free chlorine
216 concentration by 0.01 mg/L.

217 SPAC particles in the withdrawn water were collected on an aluminum oxide membrane
218 filter with a pore size of 0.2 μm (Anopore; Cytiva, Massachusetts, USA), which had been coated
219 with gold to a thickness of 100 nm. The particles on the filter were observed using a field-
220 emission scanning electron microscope (acceleration voltage, 5 kV; magnification, 7500; signal,
221 LEI; working distance, 8.0 mm; JSM-7400F, JEOL Ltd., Tokyo, Japan) and an energy-
222 dispersive X-ray spectrometer (JED-2300 Analysis Station; JEOL).

223

224 **3. Results and Discussion**

225

226 *3.1. Manganese removal by SPAC and chlorine in pilot plant experiments*

227 First, we conducted experiments using a pilot plant that comprised two water treatment
228 lines. Both lines included coagulant and membrane filtration, but Line B also included SPAC
229 and chlorination processes, whereas Line A did not. The experiments were conducted twice

230 (Run 1, 1 mg/L; Run 2, 3 mg/L SPAC). During the runs, the two lines were operated
231 simultaneously to treat the same raw water, and the concentration of manganese in the raw
232 water and in the filtrates were determined periodically to evaluate removal performance (Fig.
233 2).

234 The manganese concentrations in the raw water and Line-A filtrate were comparable in both
235 runs (15–30 µg/L), indicating that soluble manganese was not removed by coagulation and
236 membrane filtration treatment alone. In contrast, the manganese concentration in the Line-B
237 filtrate in both runs was much lower than that in the raw water and Line-A filtrate. The
238 maximum manganese concentration in the Line-B filtrate across both runs was 4 µg/L (Run 1;
239 SPAC dosage, 1 mg/L). In Run 1, the manganese removal rate remained within the range of
240 74–88 %, which was not very high, but those removal rates were attained with a SPAC and
241 chlorine contact time of only 4 min. When the dosage of SPAC was increased to 3 mg/L (Run
242 2), removal rates >95 % were achieved, and manganese concentrations in the treated water were
243 lower than the limit of detection (1 µg/L).

244 Although these findings showed that pretreatment with SPAC and chlorination resulted in
245 a marked reduction in manganese concentration, it remained unclear whether this removal was
246 the result of chlorine-mediated oxidation of Mn(II) to tetravalent Mn (Mn(IV)) (Civardi and
247 Tompeck, 2015), adsorption of the Mn(II) on the surface of the SPAC (Akl et al., 2013; Jusoh
248 et al., 2005), or a combination of the effects of both the SPAC and chlorine. Therefore, we next
249 conducted a series of batch experiments to examine the removal mechanism and kinetics
250 underlying the observed manganese removal.

251

252 3.2. Oxidation of Mn(II) by SPAC and chlorine

253 To determine whether the observed removal of Mn(II) was a result of the action of the
254 chlorine alone, SPAC alone, or the combined action of both, we conducted a series of batch

255 experiments and examined the change of Mn(II) concentrations under three conditions: the
256 presence of SPAC alone (absence of chlorine), the presence of chlorine alone (absence of
257 SPAC), or the presence of both SPAC and chlorine. The initial Mn(II) concentration was 10
258 $\mu\text{g/L}$, and the dosages of SPAC and chlorine were 1.0 mg/L and 1.0 mg-Cl₂/L, respectively.
259 During the runs, the concentrations of Mn(II) and free chlorine in the filtrate were determined
260 periodically to evaluate removal performance (Fig. 3).

261 The use of either SPAC or chlorine alone resulted in almost no change in the Mn(II)
262 concentration (proportion of Mn(II) remaining at 15 min was >99 %). Thus, chlorine alone at
263 1.0 mg-Cl₂/L was not enough to oxidize the Mn(II), and even if the activated carbon had some
264 ability to adsorb Mn(II), that ability was insufficient to remove Mn(II) under these conditions.
265 In contrast, combination treatment with SPAC and chlorine resulted in a marked decrease in
266 the Mn(II) concentration. The 90 % removal rate that was achieved within 10 min indicated
267 that the removal of Mn(II) observed in the previous pilot plant experiment was due to a
268 synergistic effect between SPAC and chlorine. Mn removal rates were comparable in the pH
269 range from 6.8 to 7.8, including the pH under which the pilot plant experiments were conducted
270 (Fig. S1, SI).

271 Based on these findings, we hypothesized that Mn(II) was oxidized to Mn(IV) by chlorine
272 on the surface of SPAC (we later learned that Li et al. (2019a) had already reported this
273 phenomenon for PAC). To examine this hypothesis further, we further conducted the batch
274 experiments using combination pretreatment with SPAC and chlorine and collected samples of
275 the SPAC. Fig. 4 shows representative field-emission scanning electron microscope
276 photographs of the SPAC particles sampled during this experiment. When no Mn(II) or a low
277 initial Mn concentration (50 $\mu\text{g/L}$) was used, the appearance of the SPAC particles remained
278 unchanged (Fig. 4A and B). However, when a high initial Mn(II) concentration (500 $\mu\text{g/L}$) was
279 used, the SPAC particles were covered in protrusions (Fig. 4C).

280 To further examine the change in appearance of the sampled particles, we repeated the
281 previous experiment but extended the Mn-chlorine-SPAC contact time to 120 min and used
282 energy-dispersive X-ray spectroscopy mapping analysis to examine a representative particle
283 sampled during the experiment (Fig. 5). Fig. 5A shows a field-emission scanning electron
284 microscope image of the sampled particle. Higher elemental manganese signals were observed
285 in the protrusions than in the body of the particle (Fig. 5B), whereas higher elemental carbon
286 signals were observed in the body of the particle than in the protrusions (Fig. 5C). Elemental
287 oxygen signals were also higher in the protrusions than in the particle body, but the difference
288 between the signals was barely detectable. (Fig. 5D). Together, these observations indicated
289 that Mn oxide had precipitated on the surface of the activated carbon. In addition, the protruding
290 nature of the precipitate suggests that the Mn oxide induced further oxidation of the Mn(II) in
291 an autocatalytic manner (Coffey et al., 1993; Nakanishi, 1967; Singer and Reckhow, 2011).

292

293 3.3. Removal rate coefficient and its independence from Mn(II) and chlorine concentration

294 We assumed that the removal of Mn by combination treatment with activated carbon and
295 chlorine observed in the pilot plant and batch experiments followed the pseudo-first-order
296 reaction kinetics of equation (1) because of the almost-perfect semi-logarithmic correlation
297 between Mn(II) concentration and time (Fig. 3A). Thus,

$$298 \quad r = -k C_{\text{Mn(II)}} \quad (1)$$

299 where r is the removal rate of Mn(II) [mmol/(L s)], k is the rate coefficient of the pseudo-
300 first-order reaction (s^{-1}), and $C_{\text{Mn(II)}}$ is the bulk-phase Mn(II) concentration (mmol/L).

301 Li et al. (2019a) have interpreted the pseudo-first-order reaction kinetics of Mn(II) removal
302 from the perspective of chemical oxidation. However, we applied an external-film mass transfer
303 model because this model has been widely used to describe Mn(II) removal by MnOx-coated
304 filter media in the presence of chlorine in previous studies (Bierlein et al., 2015; Dashtban

305 Kenari et al., 2019; Merkle et al., 1997). These studies present the model equations in the form
 306 of removal kinetics using filter media, but the basic form of the reaction kinetics can be written
 307 as follows:

$$308 \quad r = -k_f \frac{A C_S}{\rho} (C_{Mn(II)} - C_{E,Mn(II)}) \quad (2)$$

$$310 \quad C_{E,Mn(II)} = fun(q_{Mn(II)}) \quad (3)$$

$$312 \quad \frac{dq_{Mn(II)}}{dt} = k_f (C_{Mn(II)} - C_{E,Mn(II)}) - k_{Cl_2} q_{Mn(II)} C_{Cl_2} \quad (4)$$

314 where k_f is the mass transfer coefficient (m/s), A is the specific external surface area of the
 315 catalytic oxidation media (m^2/m^3), C_S is the concentration of the catalytic oxidation media
 316 (g/m^3), ρ is the density of the catalytic oxidation media (g/m^3), $C_{E,Mn(II)}$ is the Mn(II)
 317 concentration in equilibrium with adsorbed-phase Mn(II) (mmol/L), $q_{Mn(II)}$ is the mass of
 318 adsorbed-phase Mn(II) per unit of media surface (mol/m^2), $C_{E,Mn(II)} = fun(q_{Mn(II)})$ is the
 319 equilibrium relationship between the bulk liquid-phase and adsorbed-phase Mn(II)
 320 concentrations, t is time (s), k_{Cl_2} is the oxidation reaction rate coefficient [$m^3/(mol s)$], and C_{Cl_2}
 321 is chlorine concentration (mol/m^3).

322 If a similar model of equations (2–4) is applicable to Mn(II) removal by activated carbon in
 323 the presence of chlorine, our observation of the semi-logarithmic correlation would suggest the
 324 following condition: $C_{Mn(II)} \gg C_{E,Mn}$. This condition holds when $C_{Mn(II)}$ is small relative to
 325 C_{Cl_2} because $q_{Mn(II)}$ and $C_{E,Mn}$ are kept small according to equation (4) and (3), respectively. If
 326 equation (1) holds under this condition:

$$327 \quad r \cong -k_f \frac{A C_S}{\rho} C_{Mn(II)} = -k_C C_S C_{Mn(II)} = -k C_{Mn(II)}$$

328

(5)

329 where k_C is the carbon-dosage-normalized rate coefficient of the pseudo-first-order reaction
330 $[L/(mg\ s)]$. Thus, according to equation (5), the rate coefficients k and k_C should be independent
331 of Mn(II) and chlorine concentrations.

332 To confirm this hypothesis, we experimentally investigated the effects of Mn(II) and
333 chlorine concentrations on the rate of Mn(II) removal. First, the effect of initial Mn(II)
334 concentration on Mn(II) removal was examined using three initial Mn(II) concentrations (10,
335 50, and 500 $\mu\text{g/L}$) and 6 different activated carbons (Fig. 6 and Fig. S2, SI). When low initial
336 Mn(II) concentrations were used (10 and 50 $\mu\text{g/L}$), the changes in the proportion of Mn(II)
337 remaining were comparable and were fitted with similar k_C values. However, when a high initial
338 Mn(II) concentration was used (500 $\mu\text{g/L}$), the change in the proportion of Mn(II) remaining
339 was slower than the changes at the low initial concentrations. These results indicate that the
340 condition discussed above was actually held at low initial Mn(II) concentration but not at high
341 Mn(II) concentration. At high Mn(II) concentrations $q_{\text{Mn(II)}}$ becomes large, such that the
342 condition ($C_{\text{Mn(II)}} \gg C_{\text{E,Mn}}$) does not hold, and the overall removal rate is lowered. In addition,
343 we hypothesize that at high Mn(II) concentrations, a large amount of Mn(II) is precipitated on
344 the surface of the activated carbon, entirely covering the surface in a short period of time and
345 resulting in the Mn(II) being removed by the precipitated Mn oxide rather than the activated
346 carbon. Indeed, field-emission scanning electron microscopy analysis revealed visible Mn(II)
347 precipitation when a high initial Mn(II) concentration was used (Fig. 4C) but not when a low
348 initial Mn(II) concentration was used (Fig. 4B).

349 Next, we examined the effect of chlorine concentration on reaction rate by examining the
350 relationship between k_C and chlorine concentration (Fig. 7). k_C was used as an index of reaction
351 rate because of the semi-logarithmic correlation between Mn(II) concentration and time, as
352 described previously in Section 3.3. Because the residual free chlorine concentration gradually

353 decreased with time due to chlorine reductions in association with the SPAC present (Fig. 3B),
354 the residual free chlorine concentrations during the reaction were examined. When the initial
355 Mn(II) concentration was 10 $\mu\text{g/L}$, k_C did not change with chlorine concentration. In contrast,
356 when the initial Mn(II) concentration was 50 $\mu\text{g/L}$, k_C tended to decrease as the chlorine
357 concentration decreased; however, little change in the reduction of Mn(II) concentration was
358 observed (Fig S3, SI). Thus, we conclude that the dependence of k_C on chlorine concentration
359 was small, confirming our prediction that k and k_C would be independent of chlorine
360 concentration when equation (5) was derived from equations (2) to (4). Bierlein et al. (2015)
361 and Knocke et al. (2010) have reported similar results for the effect of free chlorine
362 concentration on the removal of Mn(II) by MnOx. Li et al. (2019a) have also reported no change
363 in the Mn(II) removal rate at chlorine doses of 1 to 4 mg/L. However, it does not mean no
364 requirement of chlorine for the Mn(II) removal. Mn(II) was not removed without chlorine (Fig.
365 3A). Therefore, there may exist a minimal chlorine concentration for the removal. Further
366 examinations of the role played by free chlorine in the removal of Mn(II) by activated carbon
367 are needed. This may be elucidated more quantitatively by identifying the parameters of
368 Equations 2-4 and the reaction equations of chlorine and activated carbon and solving these
369 equations simultaneously.

370

371 3.4. *Effect of activated carbon particle size on the removal of Mn(II)*

372 As shown in Fig. 6, the Mn(II) removal rates of SPAC-T₄, SPAC-T₃, and PAC-T differed
373 greatly, suggesting that the particle size of the activated carbon had a marked effect on the
374 Mn(II) removal rate. The data also suggested that removal of Mn(II) at a level suitable for real
375 world use (e.g., >97 % removal within 10 min) could be achieved by using 1 mg/L of one of
376 the SPACs, but not by using the PAC because the removal rate was too slow. To further examine
377 the effect of activated carbon particle size on the reaction rate, we conducted batch experiments

378 using nine activated carbons with different particle sizes (Table 1) and two initial concentrations
379 of Mn(II) (10 or 50 $\mu\text{g/L}$). Plots of reaction rate parameters versus activated carbon particle size
380 are shown in Fig. 8. The changes of Mn(II) concentration over time in each experiment are
381 shown in Fig. S4 (SI).

382 First, when k_C was plotted against the median diameter of the true particle size distribution
383 (true D50), k_C was found to increase with decreasing activated carbon particle size (Fig. 8A,
384 circles and triangles). Decreasing the true D50 from 30 to 1.0 μm resulted in an increase of k_C
385 by approximately 20 times. The k_C value of 1.0- μm SPAC was larger than the k_C value of 30-
386 μm PAC (0.006 L/(mg s) vs. 0.0003 L/(mg s)).

387 Next, the data from the pilot experiment (see Section 3.1) and Li et al. (2019a) were fitted
388 to equation (5), and the obtained k_C values were added to Fig. 8A. The k_C values of the pilot
389 experiment were higher than those of the batch experiments, and the k_C values reported by Li
390 et al. (2019a) were lower than those of the batch experiment. We had expected the k_C values
391 obtained from equation (5), which assumes that external-film mass transfer is the rate-
392 determining step, to be different between experiments because of differences in the stirring and
393 mixing conditions used, but we were surprised to find that the values were somewhat
394 comparable, indicating that the turbulence intensities in our batch experiment, our pilot plant
395 experiment, and the batch experiment of Li et al. (2019a) were coincidentally similar. Most
396 importantly though, the data clearly showed that micro-milling improved the Mn(II) removal
397 efficiency of activated carbon.

398 When the true D50 was decreased from 30 to 1 μm , the rate of increase of k_C was reduced,
399 and the k_C values remained at a constant value when the true D50 was less than 1 μm . Bonvin
400 et al. (2016) and Pan et al. (2016) have reported that carbon particles in suspension can exist as
401 aggregates rather than as discrete particles. We therefore hypothesized that the SPACs used in
402 the Mn(II) removal experiments were aggregated and examined this hypothesis by measuring

403 as-is particle sizes, which were determined without any pretreatment, and comparing them with
404 the true particle sizes (Fig S5, SI). The true and as-is D50 values were comparable for the four
405 largest activated carbons, but not for the remaining smaller activated carbons, for which the as-
406 is D50 was much larger than the true D50, indicating marked aggregation. That is, the as-is D50
407 did not change even though the true D50 was decreased to the submicron range by the micro-
408 milling.

409 Then, we plotted k_C versus as-is D50 (Fig. 8B) and found a fairly strong linear relationship
410 ($R^2 = 0.93$), suggesting that particle aggregation was the primary reason why k_C remained
411 unchanged when plotted against the true D50 of the activated carbon in the submicron range.
412 This is reasonable because the external-film mass transfer model behind the pseudo-first-order
413 reaction kinetics (see Section 3.3) implicitly assumes that the rate-determining step of the
414 overall Mn(II) removal kinetics is mass transfer from the bulk liquid to the external surface of
415 the activated carbon particles. If the external-film mass transfer is the rate-determining step, the
416 overall reaction rate coefficient should vary with the as-is particle size, or more precisely with
417 the external surface area. In contrast, if the rate-determining step is the chemical oxidation
418 reaction on the activated carbon surface, the overall reaction rate coefficient should vary with
419 the true particle size rather than with the as-is particle size. The higher correlation of the overall
420 reaction rate coefficient with as-is D50 (Fig. 8B) compared with true D50 (Fig. 8A) strongly
421 suggests that the external-film mass transfer, not the chemical oxidation reaction, is the rate-
422 determining step.

423 Finally, we calculated the specific apparent external surface area of the activated carbon
424 particles using the as-is particle size distribution and then calculated the values of the mass
425 transfer coefficient (k_f) according to equation (5). Similar to what was found for k_C , k_f was found
426 to change with increasing as-is D50 (Fig. S6, SI). Many correlation equations that include the
427 relationship between k_f values and particle sizes have been proposed for mass transfer to

428 particles in agitated water, among which Armenante and Kirwan (1989) proposed the following
429 correlation equation for microparticles:

430

$$431 \quad \text{Sh} \equiv \frac{k_f d}{D_w} = 2 + 0.52 \left(\frac{d^{4/3} \epsilon^{1/3}}{\sigma} \right)^{0.52} \left(\frac{\sigma}{D_w} \right)^{1/3}$$

432 (6)

433 where Sh is the Sherwood number (dimensionless), d is the diameter of the microparticles (m),
434 D_w is the diffusion coefficient in water (m^2/s), ϵ is the power input per mass of water (m^2/s^3),
435 and σ is the kinematic viscosity (m^2/s). This equation tells us that the value of Sh minus 2 varies
436 in proportion to the 0.69th power of the particle size.

437 Fig. 8C shows a plot of Sh minus 2 versus as-is D50 for our data. To determine the Sh value,
438 the diffusion coefficient of hydrated Mn(II) ions in water was obtained from the works of Buffle
439 et al. (2007) and Patil et al. (1991, 1982), and the density of activated carbon was obtained from
440 the work of Pan et al. (2016). A fairly good positive correlation with a slope of 0.83 was
441 observed, which is larger than the predicted slope of 0.69. Our data were obtained for less-
442 spherical particles with a wider particle size distribution (Fig. S7, SI) than those used to derive
443 equation (6); therefore, we consider the fit to be good for a dimensionless number correlation
444 of this kind. Overall, the general trend that for small particles (diameter $< 100 \mu\text{m}$), mass
445 transfer coefficient increase with the decrease in particle size was held in our data (Fig. S6, SI)
446 (Upadhyay et al., 1994). Thus, these findings further support that the external-film mass transfer
447 is the rate-determining step.

448 When interpreting the above results from a practical standpoint, a particle size of
449 approximately 1–2 μm seems the most appropriate for Mn(II) removal because particles below
450 1 μm are severely aggregated, reducing removal efficiency (Fig. 8 and Fig. S5, SI). A wet-
451 milling process was used in this study, but it is known that aggregation occurs more severely in

452 dry-milling processes (Pan et al., 2016). Therefore, the optimal particle size can vary depending
453 on the applied milling system and condition. Even if activated carbon particles are aggregated,
454 they could potentially have much faster Mn(II) removal if adequate dispersal could be achieved.
455 Therefore, studies on milling and dispersion of SPAC to examine the potential for drinking
456 water treatment are needed.

457

458

459 **4. Conclusions**

460 (1) Soluble Mn(II) was removed by SPAC in the presence of chlorine at feasible rates for
461 practical application. In a pilot-scale membrane filtration experiment, within 4 min of contact
462 with 3-mg/L SPAC, over 95 % of Mn(II) was removed, and a Mn(II) concentration less than
463 the limit of detection (1 µg/L) was attained. Activated carbon was found to have a similar
464 capability as Mn oxide for oxidative removal of Mn(II).

465 (2) The Mn(II) removal kinetics were well described by the pseudo-first-order reaction model
466 by using the external-film mass transfer model. The carbon-dosage-normalized pseudo-first-
467 order reaction rate coefficient value was independent of Mn(II) concentration, except at high
468 Mn(II) concentrations, and was also independent of chlorine concentration.

469 (3) The carbon-dosage-normalized pseudo-first-order reaction coefficient increased in inverse
470 proportion to the as-is particle size of activated carbon and in proportion to the specific apparent
471 external surface area because the overall rate-determining step of Mn(II) removal was the
472 external-film mass-transfer step. Practical removal of Mn(II) was found to be achievable with
473 SPAC but not with PAC.

474 (4) The as-is size of the particles with a true size of less than 1–2 µm were almost constant
475 because of particle aggregation. The carbon-dosage-normalized pseudo-first-order reaction
476 coefficients were unchanged with true particle size for such particles. SPAC with a particle size

477 of around 1–2 μm was the most appropriate for Mn(II) removal. On the other hand, if effective
478 dispersion processing of the aggregated particles is carried out in practice, a further increase in
479 removal efficiency can be expected.

480

481

482 **Acknowledgments**

483 The authors gratefully acknowledge Futamura Chemical for providing the PAC samples
484 (Nagoya, Japan). This work was supported by the Japan Society for the Promotion of Science
485 [grant number JP16H06362]. The membrane filtration pilot experiment was part of the result
486 of a joint research project of Sapporo Waterworks Bureau (Sapporo, Japan) and Metawater Co.,
487 Ltd. (Tokyo, Japan). However, the present work has not been evaluated by those entities and
488 does not necessarily reflect their opinion; therefore, no official endorsement should be inferred.

489

490

491 **References**

492 Akl, M.A., Yousef, A.M., AbdElnasser, S., 2013. Removal of Iron and Manganese in Water
493 Samples Using Activated Carbon Derived from Local Agro-Residues. *J. Chem. Eng.*
494 *Process Technol.* 04. <https://doi.org/10.4172/2157-7048.1000154>

495 Ando, N., Matsui, Y., Kurotobi, R., Nakano, Y., Matsushita, T., Ohno, K., 2010. Comparison
496 of natural organic matter adsorption capacities of super-powdered activated carbon and
497 powdered activated Carbon. *Water Res.* 44, 4127–4136.

498 <https://doi.org/10.1016/j.watres.2010.05.029>

499 Armenante, P.M., Kirwan, D.J., 1989. Mass transfer to microparticles in agitated systems.

500 *Chem. Eng. Sci.* 44, 2781–2796. [https://doi.org/10.1016/0009-2509\(89\)85088-2](https://doi.org/10.1016/0009-2509(89)85088-2)

501 Bierlein, K.A., Knocke, W.R., Tobiason, J.E., Subramaniam, A., Pham, M., Little, J.C., 2015.
502 Modeling manganese removal in a pilot-scale postfiltration contactor. *J. Am. Water*
503 *Works Assoc.* 107, E109–E119. <https://doi.org/10.5942/jawwa.2015.107.0023>

504 Bonvin, F., Jost, L., Randin, L., Bonvin, E., Kohn, T., 2016. Super-fine powdered activated
505 carbon (SPAC) for efficient removal of micropollutants from wastewater treatment plant
506 effluent. *Water Res.* 90, 90–99. <https://doi.org/10.1016/j.watres.2015.12.001>

507 Buffle, J., Zhang, Z., Startchev, K., 2007. Metal flux and dynamic speciation at
508 (Bio)interfaces. Part I: Critical evaluation and compilation of physicochemical
509 parameters for complexes with simple ligands and fulvic/humic substances. *Environ. Sci.*
510 *Technol.* 41, 7609–7620. <https://doi.org/10.1021/es070702p>

511 Carlson, K.H., Knocke, W.R., Gertig, K.R., 1997. Optimizing treatment through Fe and Mn
512 fractionation. *J. / Am. Water Work. Assoc.* 89, 162–171. [https://doi.org/10.1002/j.1551-](https://doi.org/10.1002/j.1551-8833.1997.tb08216.x)
513 [8833.1997.tb08216.x](https://doi.org/10.1002/j.1551-8833.1997.tb08216.x)

514 Cerrato, J.M., Falkinham, J.O., Dietrich, A.M., Knocke, W.R., McKinney, C.W., Pruden, A.,
515 2010. Manganese-oxidizing and -reducing microorganisms isolated from biofilms in
516 chlorinated drinking water systems. *Water Res.* 44, 3935–3945.
517 <https://doi.org/10.1016/j.watres.2010.04.037>

518 Civardi, J., Tompeck, M., 2015. Iron and manganese removal handbook, American Water
519 Works Association.

520 Coffey, B.M., Gallagher, D.L., Knocke, W.R., 1993. Modeling Soluble Manganese Removal
521 by Oxide-Coated Filter Media. *J. Environ. Eng.* 119, 679–694.
522 [https://doi.org/10.1061/\(ASCE\)0733-9372\(1993\)119:4\(679\)](https://doi.org/10.1061/(ASCE)0733-9372(1993)119:4(679))

523 Crittenden, J.C., Trussell, R.R., Hand, D.W., Howe, K.J., Tchobanoglous, G., 2012. MWH's
524 Water Treatment: Principles and Design, third. ed. John Wiley & Sons, Inc., Hoboken,
525 NJ, USA. <https://doi.org/10.1002/9781118131473>

526 Dashtban Kenari, S.L., Shabaniyan, J., Barbeau, B., 2019. Dynamic modeling of manganese
527 removal in a pyrolusite fluidized bed contactor. *Water Res.* 154, 125–135.
528 <https://doi.org/10.1016/j.watres.2019.01.046>

529 Gillogly, T.E.T., Snoeyink, V.L., Holthouse, A., Wilson, C.M., Royal, E.P., 1998. Effect of
530 chlorine on PAC's ability to adsorb MIB. *J. / Am. Water Work. Assoc.* 90, 107–114.
531 <https://doi.org/10.1002/j.1551-8833.1998.tb08382.x>

532 Gregory, D., Carlson, K., 2003. Effect of soluble Mn concentration on oxidation kinetics. *J. /*
533 *Am. Water Work. Assoc.* 95, 98–108. [https://doi.org/10.1002/j.1551-](https://doi.org/10.1002/j.1551-8833.2003.tb10273.x)
534 [8833.2003.tb10273.x](https://doi.org/10.1002/j.1551-8833.2003.tb10273.x)

535 He, H., Di, G., Gao, X., Fei, X., 2020. Use mechanochemical activation to enhance interfacial
536 contaminant removal: A review of recent developments and mainstream techniques.
537 *Chemosphere* 243, 125339. <https://doi.org/10.1016/j.chemosphere.2019.125339>

538 Health Canada, 2019. Guidelines for Canadian Drinking Water Quality: Guideline Technical
539 Document – Manganese, The Federal-Provincial-Territorial Committee on Drinking
540 Water. Ottawa, ON, Canada.

541 Hoyland, V.W., Knocke, W.R., Falkinham, J.O., Pruden, A., Singh, G., 2014. Effect of
542 drinking water treatment process parameters on biological removal of manganese from
543 surface water. *Water Res.* 66, 31–39. <https://doi.org/10.1016/j.watres.2014.08.006>

544 Islam, A.A., Goodwill, J.E., Bouchard, R., Tobiasson, J.E., Knocke, W.R., 2010.
545 Characterization of filter media MnOX(S) surfaces and Mnremoval capability. *J. / Am.*
546 *Water Work. Assoc.* 102, 71–83. <https://doi.org/10.1002/j.1551-8833.2010.tb10188.x>

547 Jusoh, A., Cheng, W.H., Low, W.M., Nora'aini, A., Megat Mohd Noor, M.J., 2005. Study on
548 the removal of iron and manganese in groundwater by granular activated carbon.
549 *Desalination* 182, 347–353. <https://doi.org/10.1016/j.desal.2005.03.022>

550 Knocke, W.R., Occiano, S.C., Hungate, R., 1991. Removal of soluble manganese by oxide-
551 coated filter media. Sorption rate and removal mechanism issues. *J. / Am. Water Work.*
552 *Assoc.* 83, 64–69. <https://doi.org/10.1002/j.1551-8833.1991.tb07201.x>

553 Knocke, W.R., Zuravnsky, L., Little, J.C., Tobiason, J.E., 2010. Adsorptive contactors for
554 removal of soluble manganese during drinking water treatment. *J. / Am. Water Work.*
555 *Assoc.* 102, 64–75. <https://doi.org/10.1002/j.1551-8833.2010.tb10171.x>

556 Kushiro City Water Supply and Sewerage Department, 2014. The business requirement level
557 of Aikoku Water Purification Plant Renewal Project, Kushiro City, Hokkaido, Japan (in
558 Japanese). <https://www.city.kushiro.lg.jp/common/000066158.pdf>

559 Li, G., Hao, H., Zhuang, Y., Wang, Z., Shi, B., 2019a. Powdered activated carbon enhanced
560 Manganese(II) removal by chlorine oxidation. *Water Res.* 156, 287–296.
561 <https://doi.org/10.1016/j.watres.2019.03.027>

562 Li, G., Ma, X., Chen, R., Yu, Y., Tao, H., Shi, B., 2019b. Field studies of manganese
563 deposition and release in drinking water distribution systems: Insight into deposit
564 control. *Water Res.* 163. <https://doi.org/10.1016/j.watres.2019.114897>

565 Matsui, Y., Ando, N., Yoshida, T., Kurotobi, R., Matsushita, T., Ohno, K., 2011. Modeling
566 high adsorption capacity and kinetics of organic macromolecules on super-powdered
567 activated carbon. *Water Res.* 45, 1720–1728.
568 <https://doi.org/10.1016/j.watres.2010.11.020>

569 Matsushita, T., Matsui, Y., Ikekame, S., Sakuma, M., Shirasaki, N., 2017. Trichloramine
570 Removal with Activated Carbon is Governed by Two Reductive Reactions: A
571 Theoretical Approach with Diffusion-Reaction Models. *Environ. Sci. Technol.* 51.
572 <https://doi.org/10.1021/acs.est.6b05461>

573 Merkle, P.B., Knocke, W., Gallagher, D., Junta-Rosso, J., Solberg, T., 1996. Characterizing
574 filter media mineral coatings: Characterizing filter media mineral coatings using

575 analytical techniques from geological science helps unlock fundamental filtration
576 phenomena. *J. / Am. Water Work. Assoc.* 88, 62–73. <https://doi.org/10.1002/j.1551->
577 [8833.1996.tb06662.x](https://doi.org/10.1002/j.1551-8833.1996.tb06662.x)

578 Merkle, P.B., Knocke, W.R., Gallagher, D., Little, J.C., 1997. Dynamic Model for Soluble
579 Mn²⁺ Removal by Oxide-Coated Filter Media. *J. Environ. Eng.* 123, 650–658.
580 [https://doi.org/https://doi.org/10.1061/\(ASCE\)0733-9372\(1997\)123:7\(650\)](https://doi.org/10.1061/(ASCE)0733-9372(1997)123:7(650))

581 MHLWJ, 2002. The water quality standards pursuant to the provision of Article 4 of the
582 Waterworks Act, Ministry of Health, Labour and Welfare Government of Japan
583 (MHLWJ) (in Japanese). <https://www.mhlw.go.jp/shingi/2002/09/dl/s0904-4f2.pdf>

584 Mohan, D., Chander, S., 2001. Single component and multi-component adsorption of metal
585 ions by activated carbons. *Colloids Surfaces A Physicochem. Eng. Asp.* 177, 183–196.
586 [https://doi.org/10.1016/S0927-7757\(00\)00670-1](https://doi.org/10.1016/S0927-7757(00)00670-1)

587 Moriwaki, K., Sakurai, K., 2012. Report on a Pilot Test of Water Purification Treatment at the
588 Aikoku Water Purification Plant in Kushiro City, in: *Proceedings of the 63rd National*
589 *Symposium on Water Supply Research in Japan*. pp. 242-245 (in Japanese).

590 Nakanishi, H., 1967. Kinetics of Continuous Removal of Manganese in a MnO₂- Coated
591 Sand Bed. *Kogyo Kagaku Zasshi (Journal Chem. Soc. Japan)* 70(4) (in Japanese).

592 Noboribetsu City Urban Development Department, 2019. The business requirement level of
593 Noboribetsu Onsen Water Purification Plant Renewal Project, Noboribetsu City,
594 Hokkaido, Japan (in Japanese).
595 https://www.city.noboribetsu.lg.jp/docs/2019040400020/file_contents/02.pdf

596 Ohno, K., Minami, T., Matsui, Y., Magara, Y., 2008. Effects of chlorine on
597 organophosphorus pesticides adsorbed on activated carbon: Desorption and oxon
598 formation. *Water Res.* 42, 1753–1759.
599 [https://doi.org/https://doi.org/10.1016/j.watres.2007.10.040](https://doi.org/10.1016/j.watres.2007.10.040)

600 Pan, L., Matsui, Y., Matsushita, T., Shirasaki, N., 2016. Superiority of wet-milled over dry-
601 milled superfine powdered activated carbon for adsorptive 2-methylisoborneol removal.
602 Water Res. 102, 516–523. <https://doi.org/10.1016/j.watres.2016.06.062>

603 Patil, S.F., Adhyapak, N.G., Ujlambkar, S.K., 1982. Diffusion studies of manganese sulphate
604 and manganese chloride in agar gel medium. Int. J. Appl. Radiat. Isot. 33, 1433–1437.
605 [https://doi.org/10.1016/0020-708X\(82\)90182-X](https://doi.org/10.1016/0020-708X(82)90182-X)

606 Patil, S.F., Rajurkar, N.S., Borhade, A. V., 1991. Self-diffusion of cobalt and manganese ions
607 in aqueous electrolyte solutions. J. Chem. Soc. Faraday Trans. 87, 3405–3407.
608 <https://doi.org/10.1039/FT9918703405>

609 Savova, D., Petrov, N., Yardim, M., Ekinci, E., Budinova, T., Razvigorova, M., Minkova, V.,
610 2003. The influence of the texture and surface properties of carbon adsorbents obtained
611 from biomass products on the adsorption of manganese ions from aqueous solution.
612 Carbon N. Y. 41, 1897–1903. [https://doi.org/10.1016/S0008-6223\(03\)00179-9](https://doi.org/10.1016/S0008-6223(03)00179-9)

613 Singer, P.C., Reckhow, D.A., 2011. Chapter 7 Chemical oxidation, in: Edzwald, J.,
614 Association, A.W.W. (Eds.), Water Quality and Treatment: A Handbook on Drinking
615 Water. McGraw-Hill.

616 Sly, L.I., Hodgkinson, M.C., Arunpairojana, V., 1990. Deposition of manganese in a drinking
617 water distribution system. Appl. Environ. Microbiol. 56, 628–39.
618 <https://doi.org/10.2113/gsecongeo.26.8.799>

619 Snoeyink, V.L., Suidan, M.T., 1975. Dechlorination by activated carbon and other reducing
620 agents, in: Johnson, J.D. (Ed.), Disinfection: Water and Wastewater. Ann Arbor Science
621 Publishers, pp. 339–358.

622 Summers, R.S., Knappe, D.R.U., Snoeyink, V.L., 2011. Chapter 14 Adsorption of organic
623 compounds by activated carbon, in: Edzwald, J.K., Association, A.W.W. (Eds.), Water
624 Quality and Treatment: A Handbook on Drinking Water. McGraw-Hill.

625 Taffarel, S.R., Rubio, J., 2009. On the removal of Mn²⁺ ions by adsorption onto natural and
626 activated Chilean zeolites. *Miner. Eng.* 22, 336–343.
627 <https://doi.org/10.1016/j.mineng.2008.09.007>

628 Tobiason, J.E., Bazilio, A., Goodwill, J., Mai, X., Nguyen, C., 2016. Manganese Removal
629 from Drinking Water Sources. *Curr. Pollut. Reports* 2, 168–177.
630 <https://doi.org/10.1007/s40726-016-0036-2>

631 Upadhyay, S.N., Rai, B.N., Kumar, V., Shah, Y.T., 1994. PARTICLE SUSPENSION AND
632 LIQUID-SOLID MASS TRANSFER IN MECHANICALLY AGITATED VESSEL.
633 *Rev. Chem. Eng.* 10, 1–130. <https://doi.org/10.1515/REVCE.1994.10.1.1>

634 USEPA, 2004. Drinking Water Health Advisory for Manganese, U.nited States
635 Environmental Protection Agency(USEPA), Office of Water, Washington DC, USA.
636 EPA-822-R-04-003.

637 WHO, 2017. Guidelines for drinking-water quality: fourth edition incorporating the first
638 addendum. World Health Organization, Geneva, Switzerland.

639

Table 1 True median diameters of the activated carbons after the addition of dispersant and ultrasonic dispersion pretreatment

Designation		True median diameter (μm)
Commercial PAC-P	PAC-P	15.4
	SPAC-P	1.24
Commercial PAC-T	PAC-T	29.3
	SPAC-T ₁	10.1
	SPAC-T ₂	4.85
	SPAC-T ₃	2.68
	SPAC-T ₄	1.51
	SPAC-T ₅	0.79
	SSPAC-T ₁	0.43
	SSPAC-T ₂	0.17
	SSPAC-T ₃	0.16

640
641
642
643
644
645

PAC: powdered activated carbon
 SPAC: superfine powdered activated carbon
 SSPAC: submicron superfine powdered activated carbon
 PAC-P: PL-WPS (Dainen Co., Ltd., Hyogo, Japan)
 PAC-T: Taiko W (Futamura Chemical Co., Ltd., Nagoya, Japan).

Table 2 Characteristics of the raw water used in the membrane filtration pilot plant experiments

	Temperature °C	Turbidity NTU	UV260 * abs/50 mm	TOC mg/L	pH	Mn * µg/L	Al * mg/L
Run 1	7.1–11.6	5.1–9.9	0.11– 0.13	0.8–1.0	8.7–9.3	19–26	0.17–0.24
Run 2	14.1–20.1	1.5–1.9	0.11–0.14	0.9–0.9	7.3–8.3	16–27	0.09–0.09

*: analyzed after filtration

646

647

648

649

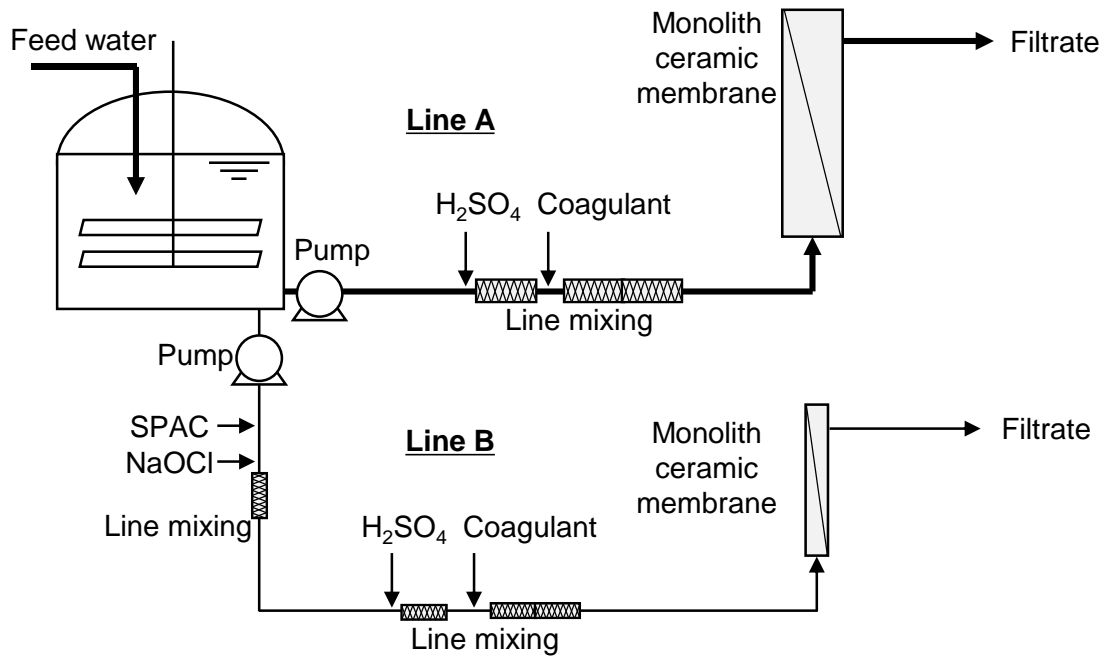

650
 651
 652
 653

Fig. 1. Membrane filtration pilot plant system.

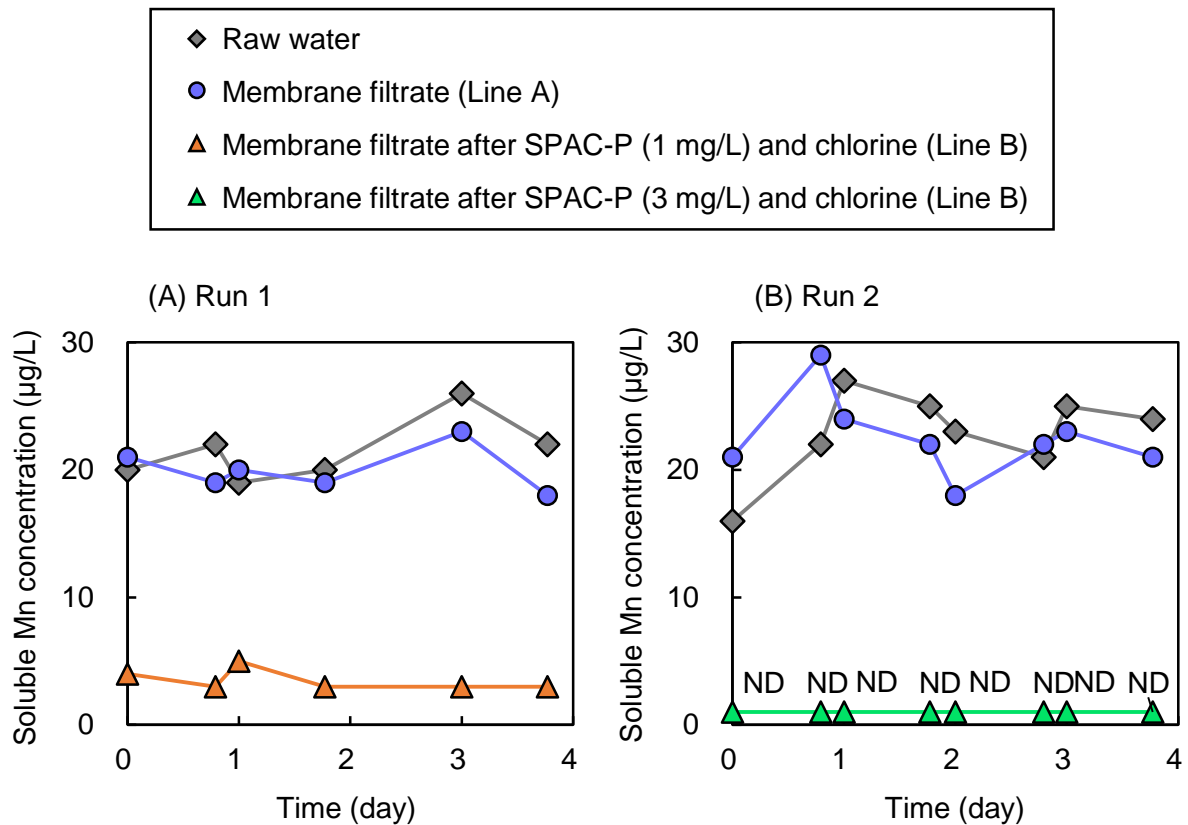

654

655 **Fig. 2.** Results of the pilot plant experiments examining the removal of soluble divalent Mn
 656 from raw water. The pilot plant comprised two treatment lines. Both lines included
 657 coagulant and membrane filtration, but Line B also included SPAC-P (D50 1.24 µm)
 658 and chlorination processes, whereas Line A did not. Two runs were conducted for each
 659 experiment with only the SPAC-P dosage differing between the runs. Chlorine dosage
 660 was controlled to maintain the residual free chlorine in membrane filtrate at 0.2 mg-
 661 Cl₂/L. ND, not detected (<1 µg/L).

662

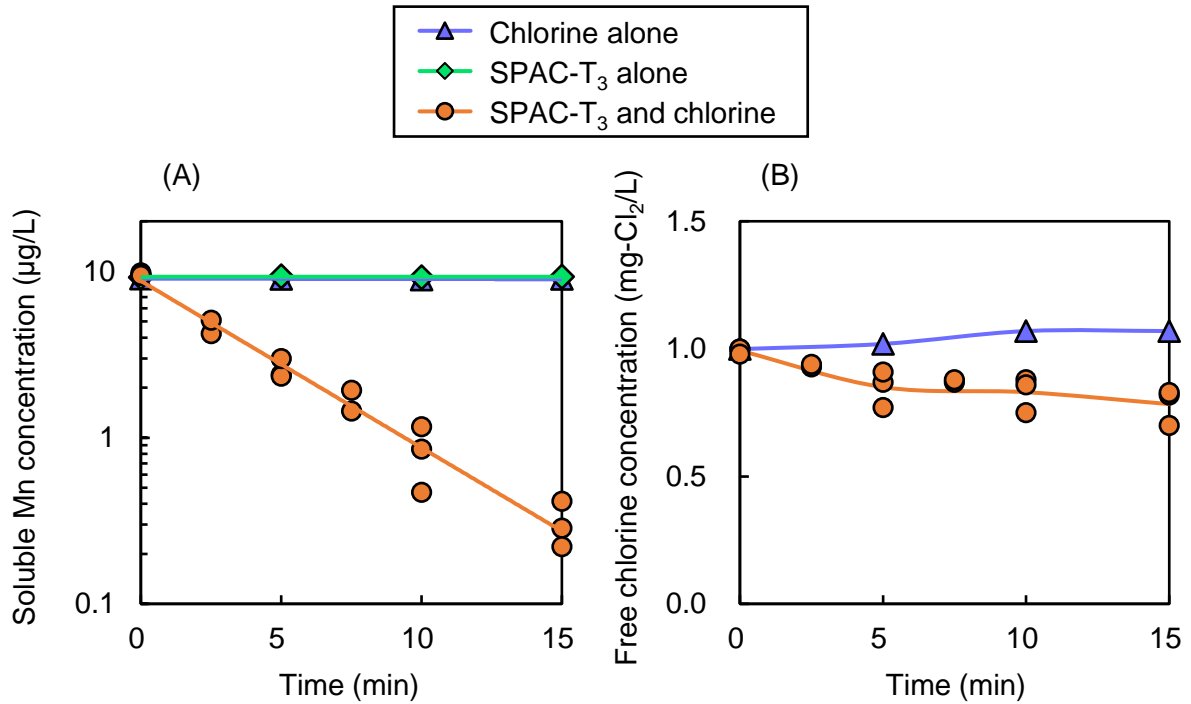

664

665 **Fig. 3.** Changes of soluble divalent Mn concentration (A) and free chlorine concentration (B)
 666 over time in the presence of chlorine alone, SPAC-T₃ (D50: 2.68 µm) alone, or both
 667 SPAC-T₃ and chlorine. Initial soluble divalent Mn concentration was 10 µg/L. Dosages
 668 of SPAC-T₃ and chlorine were 1.0 mg/L and 1.0 mg-Cl₂/L, respectively. Pure water
 669 containing carbonate buffer was used as the raw water.

670

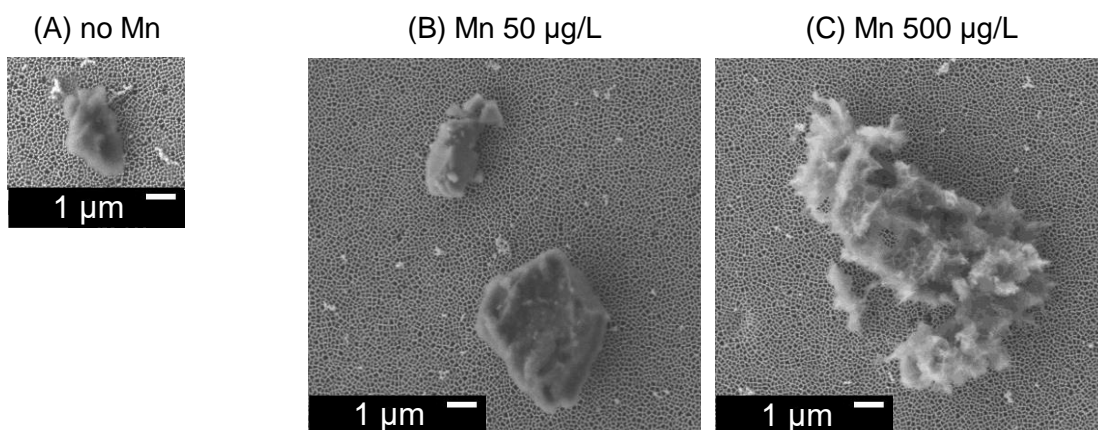

671
672 **Fig. 4.** Representative field-emission scanning electron microscopy images of SPAC-T₃ (D50:
673 2.68 µm) particles sampled during batch experiments using different initial
674 concentrations of soluble divalent Mn. Dosages of SPAC-T₃ and chlorine were 1.0
675 mg/L and 1.0 mg-Cl₂/L, respectively. Mn-chlorine-SPAC contact time was 60 min.
676 Pure water with carbonate buffer was used as the raw water. An alumina oxide
677 membrane filter with a 100-nm thick gold layer was used for particle collection.
678

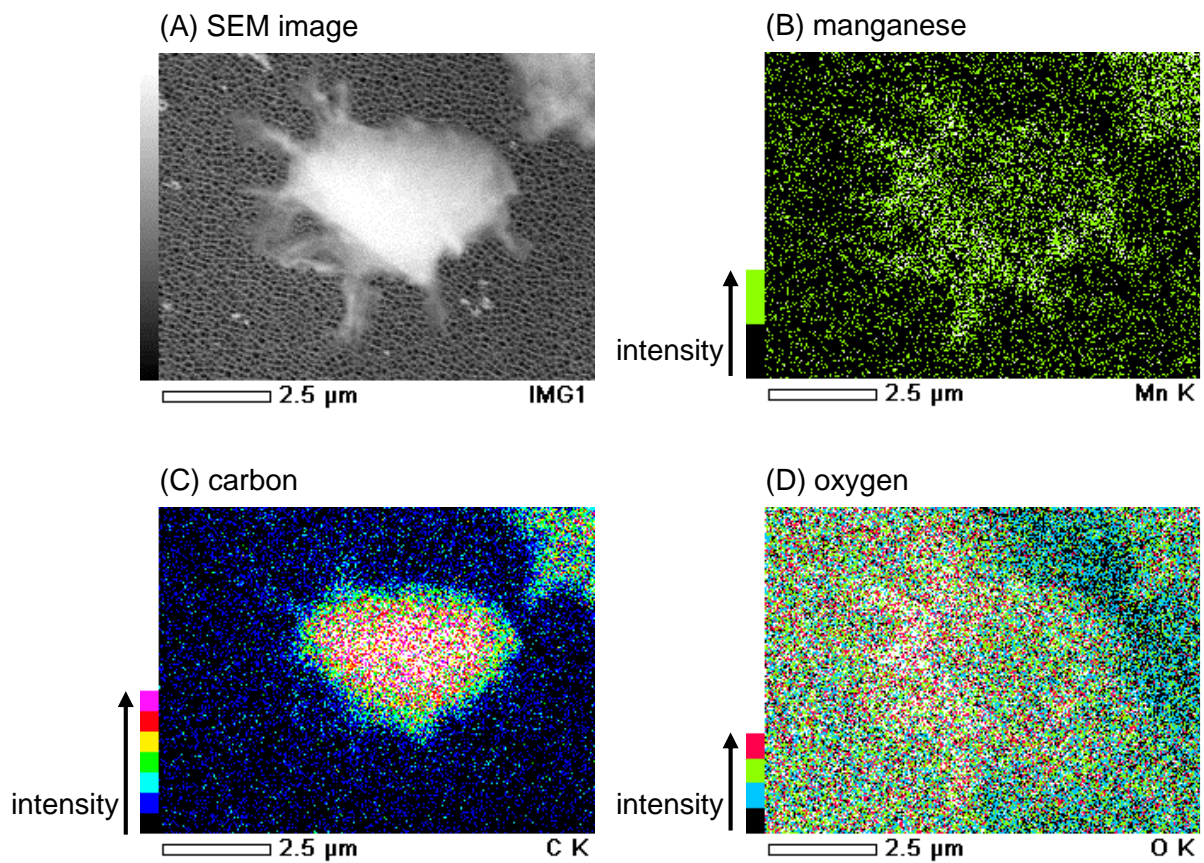

680

681

682

683

684

685

686

687

688

689

Fig. 5. Field-emission scanning electron microscopy (A) and energy-dispersive X-ray spectrometry mappings (B–D) of particles sampled from the batch experiment using combination pretreatment with SPAC-T₃ (D50: 2.68 μm) and chlorine and a high initial soluble divalent Mn concentration (500 $\mu\text{g/L}$). The dosages of SPAC-T₃ and chlorine were 1.0 mg/L and 1.0 mg-Cl₂/L, respectively. Mn-chlorine-SPAC contact time was 120 min. Pure water containing carbonate buffer was used as the raw water. An alumina oxide membrane filter with a 100-nm thick gold layer was used for particle collection.

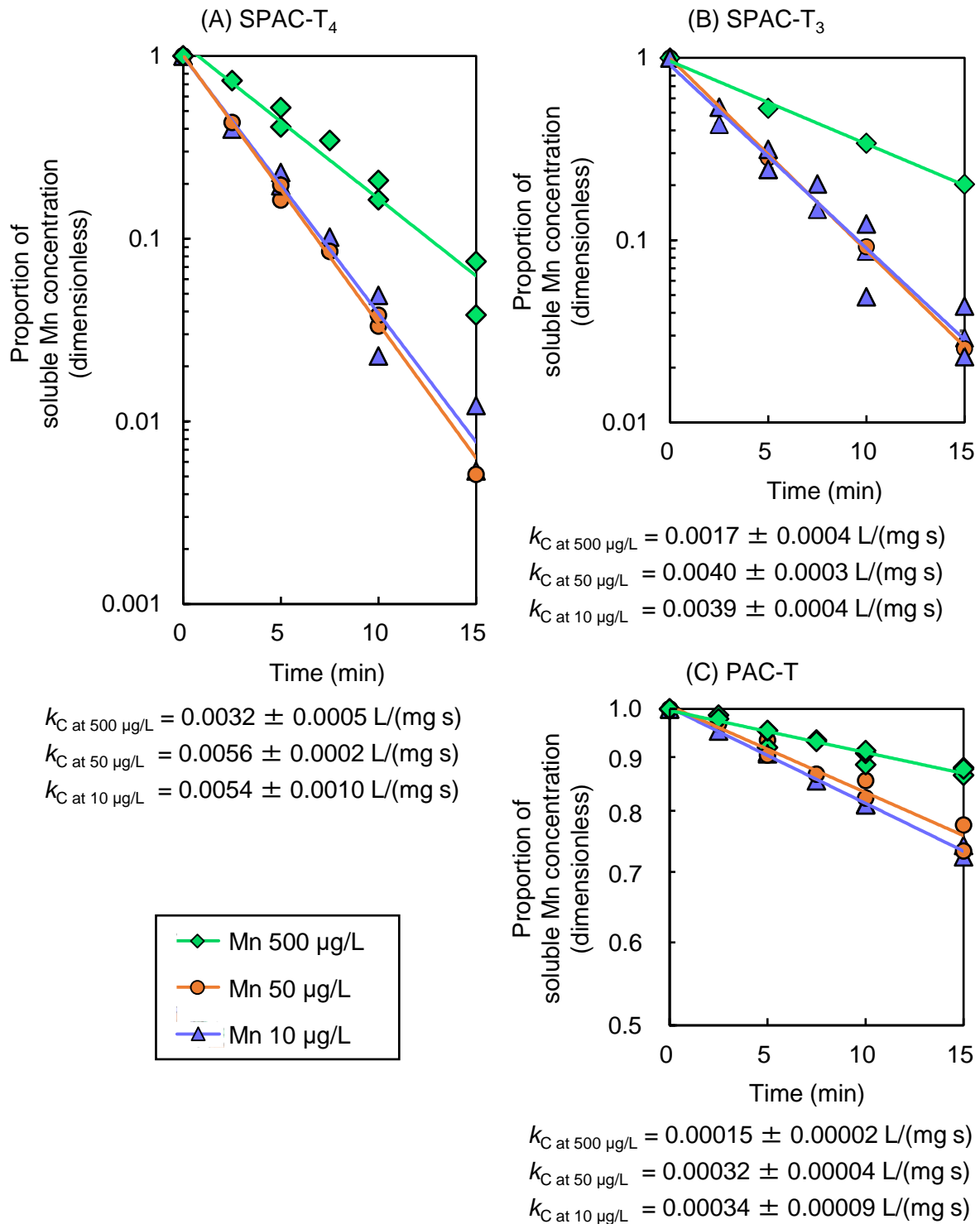

690

691 **Fig. 6.** Rate of soluble divalent Mn removal by SPAC-T₄ (D50: 1.51 µm) (A), SPAC-T₃ (2.68
 692 µm) (B), and PAC-T (29.3 µm) (C) in the presence of chlorine at three initial Mn
 693 concentrations (10, 50, and 500 µg/L). The dosages of activated carbon and chlorine
 694 were 1.0 mg/L and 1.0 mg-Cl₂/L, respectively. Pure water containing carbonate buffer
 695 was used as the raw water. k_C is the carbon-dosage-normalized pseudo-first-order
 696 reaction rate coefficient obtained by semi-logarithmic correlation between Mn
 697 concentration and time, and the 95% confidence intervals of k_C are presented.

698

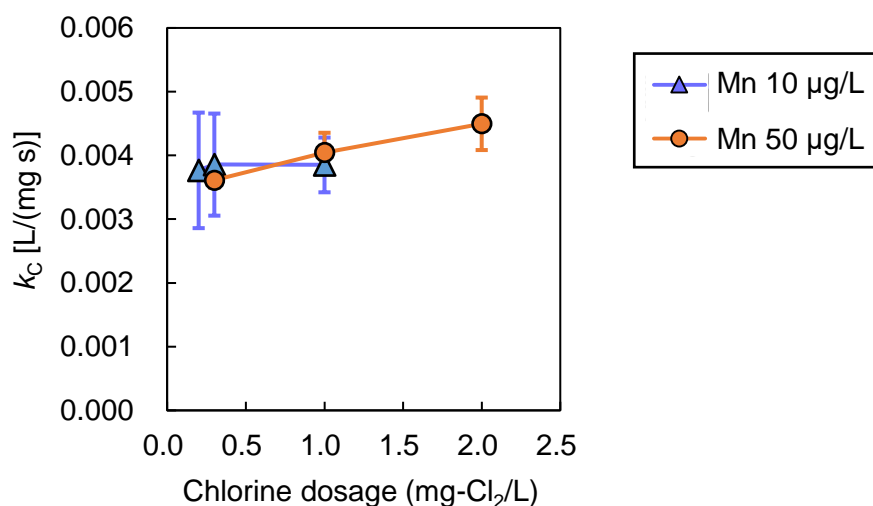

699

700

701

702 **Fig. 7.** Carbon-dosage-normalized pseudo-first-order reaction rate coefficient (k_C) versus
 703 chlorine dosage (A) and residual free chlorine concentration at 5 min (B). Experiments
 704 were conducted for two initial Mn concentrations (10 and 50 $\mu\text{g/L}$) and three chlorine
 705 dosages (data points moving left to right in both panels: 0.2, 0.3, and 1.0 $\text{mg-Cl}_2/\text{L}$ with
 706 10 $\mu\text{g-Mn/L}$; 0.3, 1.0, and 2.0 $\text{mg-Cl}_2/\text{L}$ with 50 $\mu\text{g-Mn/L}$). SPAC-T₃ (D50: 2.68 μm)
 707 was applied at a dosage of 1.0 mg/L . Pure water containing carbonate buffer was used
 708 as the raw water. The changes of soluble divalent Mn concentration and free chlorine
 709 concentration with time are shown in Fig. 1S (SI). Error bars represent 95% confidence
 710 intervals.

711

712

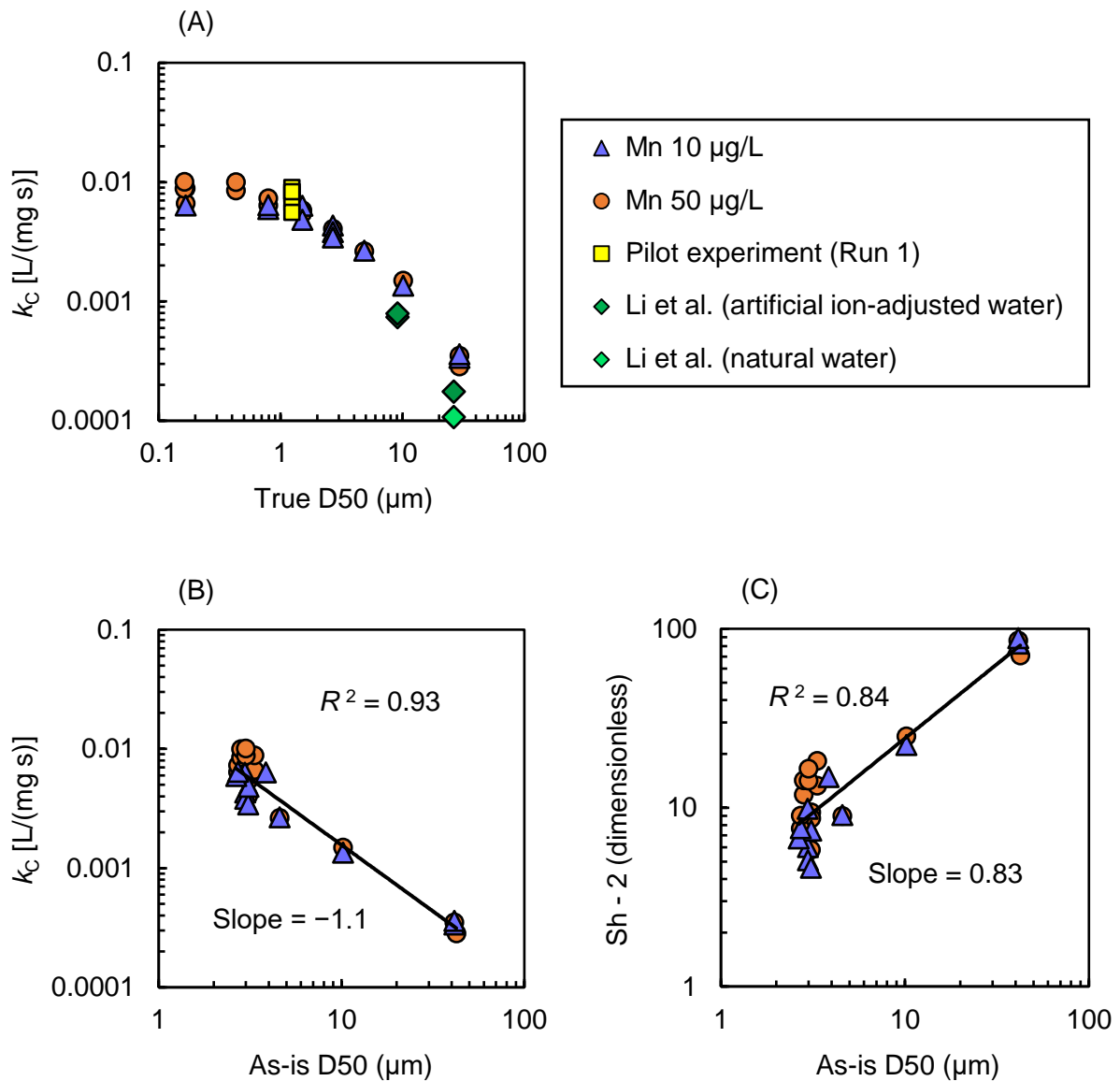

714

715 **Fig. 8.** Changes of reaction rate parameter values against activated carbon particle size. k_c is
 716 the carbon-dosage-normalized pseudo-first-order reaction rate coefficient. Sh is the
 717 Sherwood number. True D50 is the median diameter of particles in dispersed form. As-
 718 is D50 is the median diameter of particles in water without any dispersion treatment.
 719 Waters with two different initial Mn concentrations (10 and 50 $\mu\text{g/L}$) were used in the
 720 batch experiment. The dosages of activated carbon and chlorine were 1.0 mg/L and 1.0
 721 mg- Cl_2/L , respectively. Pure water containing carbonate buffer was used as the raw
 722 water. The changes of soluble Mn concentrations over time in each batch are shown in
 723 Fig. 2S (SI). The data obtained in the pilot experiment discussed in Section 3.1 and
 724 those reported by Li et al. (2019a) are plotted in panel A.

725

726

727
728
729
730
731
732
733
734
735
736
737
738
739
740
741
742
743
744
745

Supplementary Materials

Oxidative removal of soluble divalent manganese ion by chlorine in the presence of superfine powdered activated carbon

Shun Saito ^{a, b}, Yoshihiko Matsui ^{c*}, Yasuhiko Yamamoto ^b, Shuhei Matsushita ^d, Satoru Mima ^b, Nobutaka Shirasaki ^c, and Taku Matsushita ^c

- ^a Graduate School of Engineering, Hokkaido University, N13W8, Sapporo 060-8628, Japan
^b METAWATER Co., Ltd., Kandasuda-cho 1-25, Chiyoda-ku, Tokyo 101-8554, Japan
^c Faculty of Engineering, Hokkaido University, N13W8, Sapporo 060-8628, Japan
^d School of Engineering, Hokkaido University, N13W8, Sapporo 060-8628, Japan

* Corresponding author. Tel./fax: +81-11-706-7280
E-mail address: matsui@eng.hokudai.ac.jp

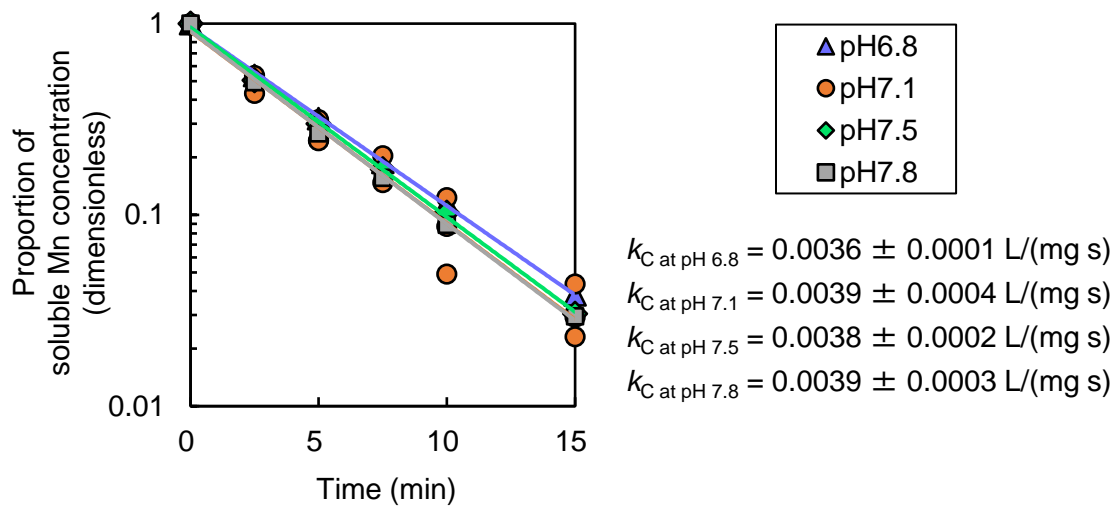

746
747
748
749
750
751
752
753
754
755
756
757
758

Fig. S1. Rate of soluble divalent Mn removal by SPAC-T₃ (D50 2.68 μm) in the presence of chlorine at four pH values (6.8, 7.1, 7.5, and 7.8). The dosages of SPAC-T₃ and chlorine were 1.0 mg/L and 1.0 mg-Cl₂/L, respectively. Pure water containing carbonate buffer was used as the raw water. k_C is the carbon-dosage-normalized pseudo-first-order reaction rate coefficient obtained by semi-logarithmic correlation between Mn concentration and time, and the 95% confidence intervals of k_C are presented.

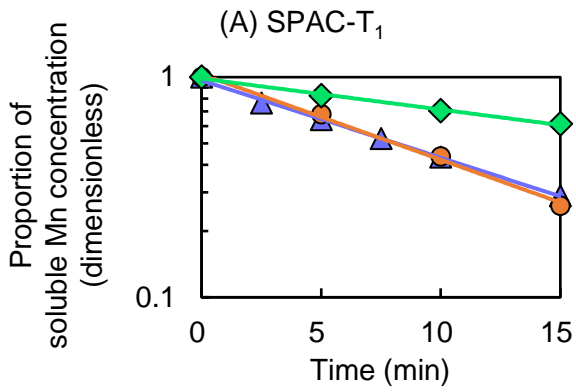

$$k_C \text{ at } 500 \mu\text{g/L} = 0.00054 \pm 0.00013 \text{ L}/(\text{mg s})$$

$$k_C \text{ at } 50 \mu\text{g/L} = 0.0015 \pm 0.0003 \text{ L}/(\text{mg s})$$

$$k_C \text{ at } 10 \mu\text{g/L} = 0.0013 \pm 0.0001 \text{ L}/(\text{mg s})$$

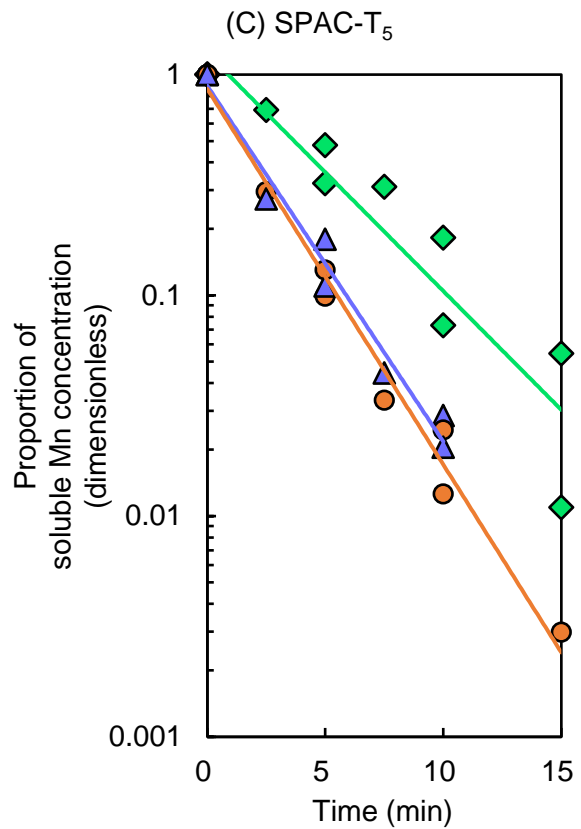

$$k_C \text{ at } 500 \mu\text{g/L} = 0.0041 \pm 0.0012 \text{ L}/(\text{mg s})$$

$$k_C \text{ at } 50 \mu\text{g/L} = 0.0065 \pm 0.0006 \text{ L}/(\text{mg s})$$

$$k_C \text{ at } 10 \mu\text{g/L} = 0.0060 \pm 0.0004 \text{ L}/(\text{mg s})$$

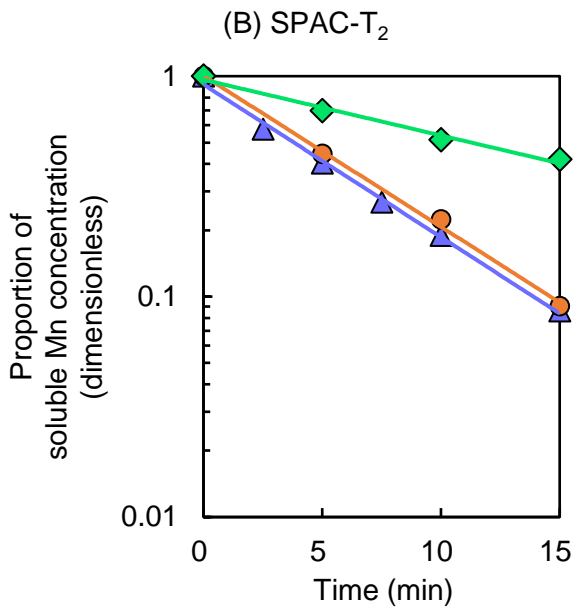

$$k_C \text{ at } 500 \mu\text{g/L} = 0.0010 \pm 0.0004 \text{ L}/(\text{mg s})$$

$$k_C \text{ at } 50 \mu\text{g/L} = 0.0026 \pm 0.0003 \text{ L}/(\text{mg s})$$

$$k_C \text{ at } 10 \mu\text{g/L} = 0.0027 \pm 0.0002 \text{ L}/(\text{mg s})$$

759
760
761
762
763
764
765
766
767
768

Fig. S2. Rate of soluble divalent Mn removal by SPAC-T₁ (D50 10.1 µm) (A), SPAC-T₂ (D50 4.85 µm) (B), and SPAC-T₅ (D50 0.79 µm) (C) in the presence of chlorine at three initial Mn concentrations (10, 50, and 500 µg/L). The dosages of activated carbon and chlorine were 1.0 mg/L and 1.0 mg-Cl₂/L, respectively. Pure water containing carbonate buffer was used as the raw water. k_C is the carbon-dosage-normalized pseudo-first-order reaction rate coefficient obtained by semi-logarithmic correlation between Mn concentration and time, and the 95% confidence intervals of k_C are presented.

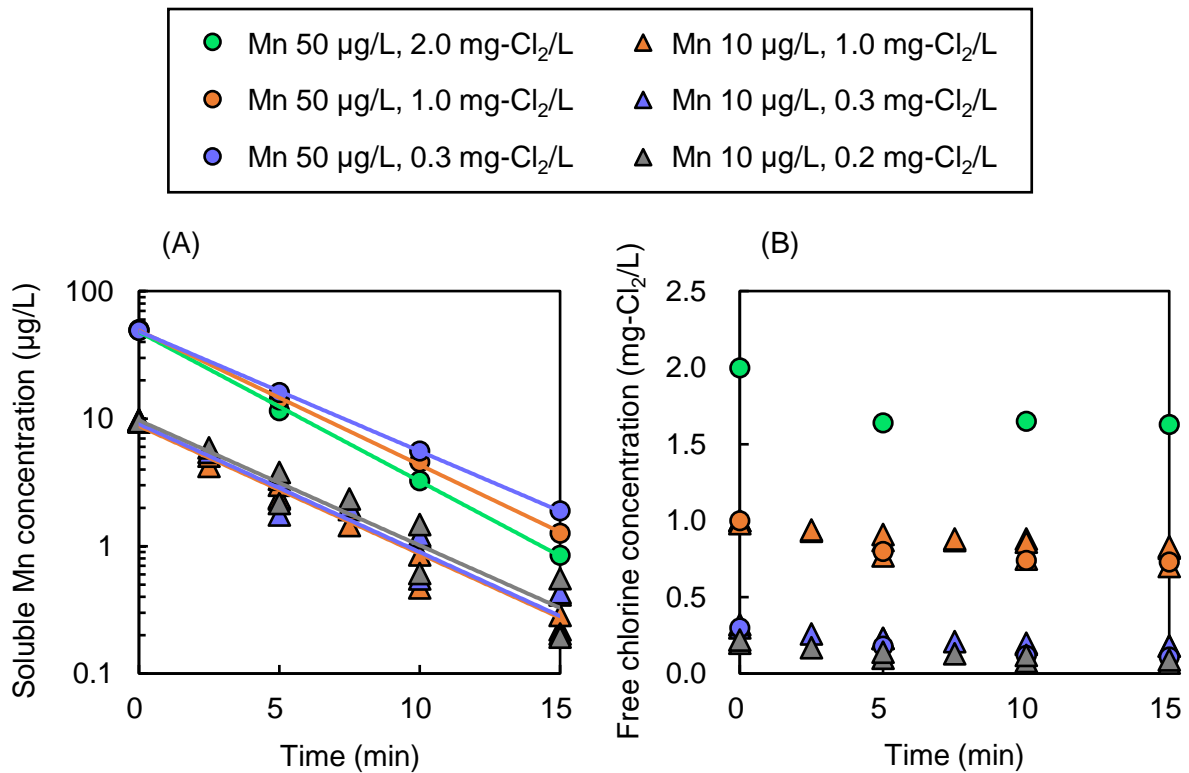

769
770
771
772
773
774
775
776

Fig. S3. Changes of soluble divalent Mn concentrations (A) and free chlorine concentrations (B) in batch experiments. Experiments were conducted for two initial Mn concentrations (10 and 50 µg/L) and three chlorine dosages. SPAC-T₃ (D50 2.68 µm) was used at a dosage of 1.0 mg/L. Pure water containing carbonate buffer was used as the raw water.

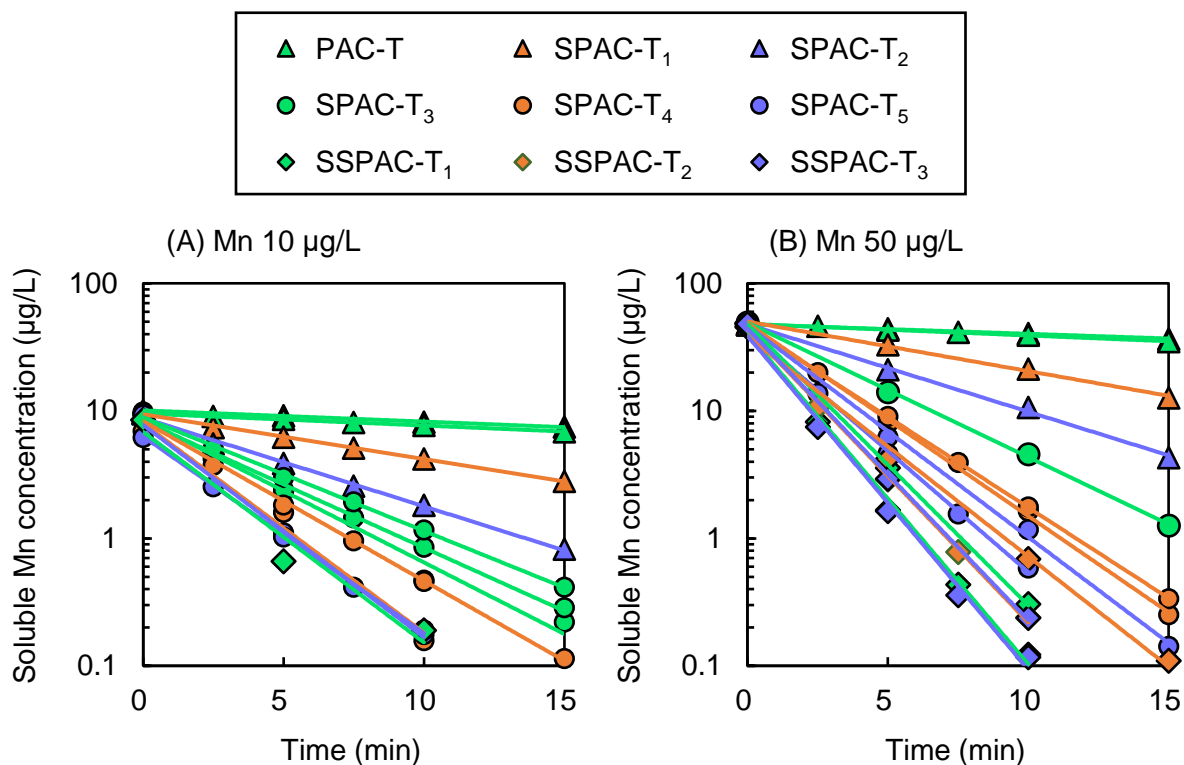

777
 778 **Fig. S4.** Changes of soluble divalent Mn concentrations in batch experiments. Two initial Mn
 779 concentrations (10 and 50 µg/L) and nine activated carbons with different particle sizes
 780 were used. The dosages of activated carbon and chlorine were 1.0 mg/L and 1.0 mg-
 781 Cl₂/L, respectively. Pure water containing carbonate buffer was used as the raw water.
 782
 783

784
785

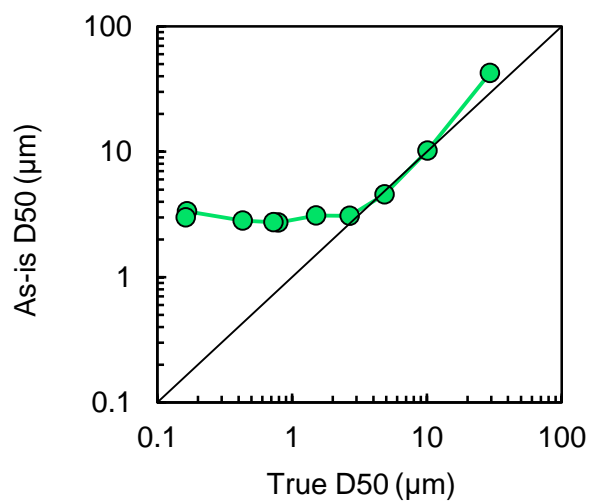

786
787 **Fig. S5.** Median diameters of the as-is particle size distributions (As-is D50) versus the true
788 particle size distributions (True D50).
789

790

791
792

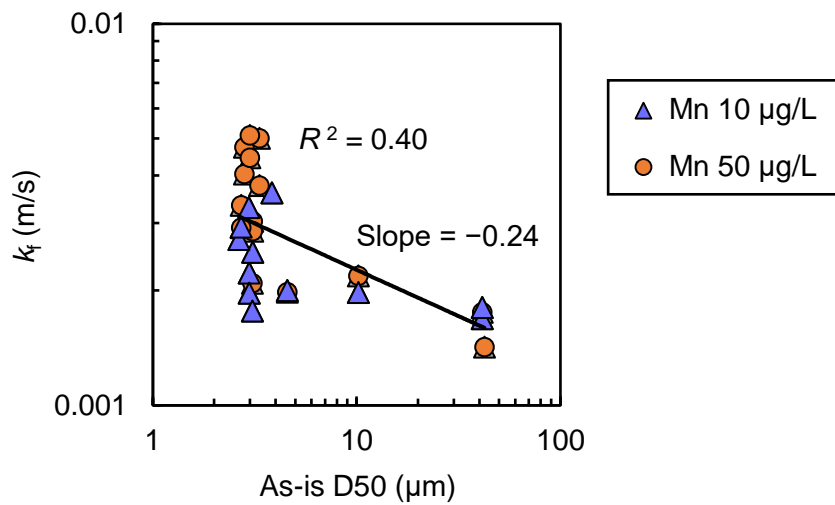

793
794
795
796
797
798
799
800
801
802

Fig. S6. Changes of mass transfer coefficient (k_f) against median diameters of the as-is particle size distributions (As-is D50). Waters with two different initial Mn concentrations (10 and 50 $\mu\text{g/L}$) were used in the batch experiment. The dosages of activated carbon and chlorine were 1.0 mg/L and 1.0 mg- Cl_2/L , respectively. Pure water containing carbonate buffer was used as the raw water. The changes of soluble Mn concentrations over time in each batch are shown in Fig. S4 (SI).

803
804

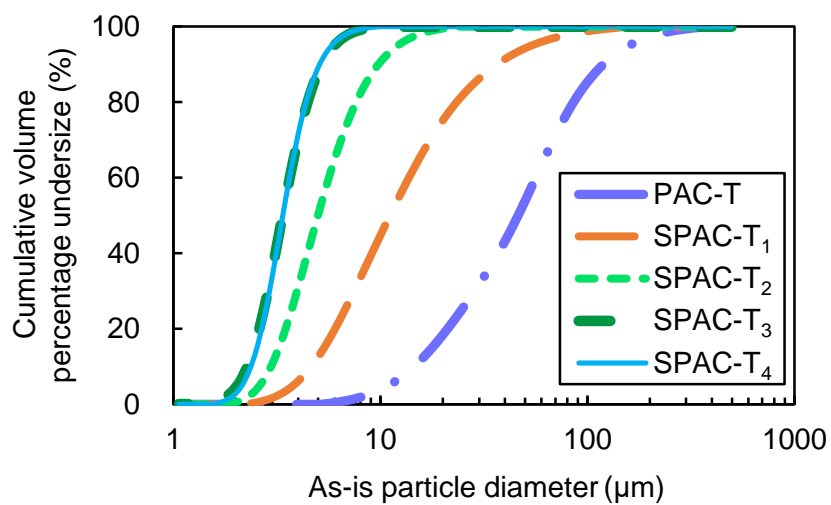

805
806

Fig. S7. As-is particle size distributions of selected activated carbons.