

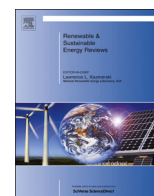

ELSEVIER

Contents lists available at [ScienceDirect](http://ScienceDirect)

# Renewable and Sustainable Energy Reviews

journal homepage: [www.elsevier.com/locate/rser](http://www.elsevier.com/locate/rser)

## A sustainable electrical interface to mitigate emissions due to power supply in ports

T. Coppola <sup>a</sup>, M. Fantauzzi <sup>b</sup>, D. Lauria <sup>a</sup>, C. Pisani <sup>c,\*</sup>, F. Quaranta <sup>a</sup><sup>a</sup> Department of Industrial Engineering, University of Naples Federico II, Via Claudio 21, 80125 Naples, Italy<sup>b</sup> Department of Electrical Engineering and Information Technology – University of Naples Federico II, Via Claudio 21, 80125 Naples, Italy<sup>c</sup> Department of Engineering – University of Sannio, Piazza Roma 21, 82100 Benevento, Italy

### ARTICLE INFO

#### Article history:

Received 22 February 2015

Received in revised form

23 July 2015

Accepted 21 October 2015

#### Keywords:

Emissions reduction  
Smart electrical interface  
Rotating converter  
Static var system  
Ship-to-shore  
Cold ironing

### ABSTRACT

The paper presents a proposal of an innovative sustainable power supply solution for seaports with the related design and control. This solution differs from the classical solution for the presence of a smart electrical interface composed by two basic components: the first one, a rotating converter-instead of the widely used static converter-that ensures higher and therefore much more detectable short-circuit currents; the second, an advanced static var compensator specifically designed for enhancing power quality issues and hence favoring the seaport connection to the main grid for cold ironing applications. The designed control strategy for the tailored power supply solution is proven successful and effective by the numerical applications reported in the last part of the paper.

© 2015 Elsevier Ltd. All rights reserved.

### Contents

1. Introduction	816
2. Methods	817
3. Theory	818
4. Calculation	818
4.1. Rotating converter modeling and control	818
4.2. Advanced static var modeling and control	820
5. Results	820
6. Discussion	823
7. Conclusions	823
References	823

## 1. Introduction

Maritime transportation will have a more and more leading role in the world trade in the next future, as confirmed by interesting recent studies carried out by some international committees [1,2]. An increase of ship number implies therefore the necessity to pay a greater attention to the thorny problem of the

correlated air pollutants emissions produced during their mooring in the ports. Actually, as well known, the ships electrical demand at berth is typically satisfied by the auxiliary engines installed on-board with consequent emission of (i) air pollutants, (ii) vibrations and (iii) acoustic noise [3]. The paper is primary focused on the former issue. The increasingly cogent international regulations regarding a low carbon economy require the immediate identification of appropriate solutions to reduce the level of emissions considerably. In this regard, a reduction of emissions has been lately pursued by employing cleaner fuels and by using more efficient energy conversion devices [4–5]. *Ship-to-shore connection*

\* Corresponding author.

E-mail addresses: [cosimopisani@gmail.com](mailto:cosimopisani@gmail.com), [cosimo.pisani@unina.it](mailto:cosimo.pisani@unina.it), [cosimo.pisani@unisannio.it](mailto:cosimo.pisani@unisannio.it) (C. Pisani).

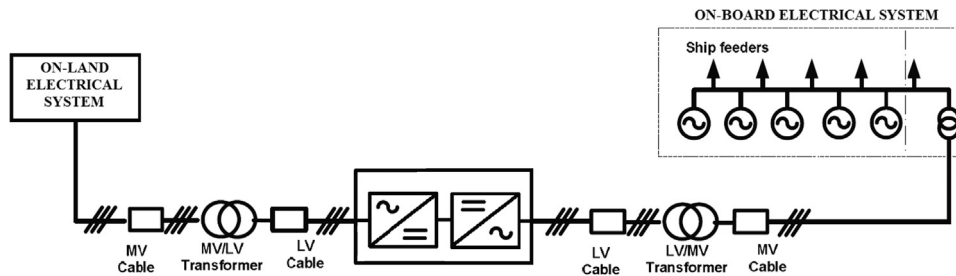

Fig. 1. High Voltage Shore Connection scheme with static frequency converter.

or *cold ironing* is an emerging paradigm of the technical literature recognized as very attractive and impactful in terms of emissions reduction targets. As a consequence, a gradual turning off of the diesel generators is expected in the future [6]. Although there is a real convenience however, from an economic point of view, the investments required to upgrade the power supply infrastructures, both onshore and onboard, are not negligible [7]. From a technical point of view instead, the most critical issue in connecting the vessel electrical system to the main grid is due to the difference between their rated voltages and frequencies [8,9]. The generic scheme of a High Voltage Shore Connection is reported in Fig. 1 [9], whose basic subsystems are:

- Main station aiming at interconnecting the main grid to the MV cable;
- MV/LV transformer;
- Low voltage frequency converter (typically of static type);
- LV/MV transformer;
- Output switchboard and protection equipment.

In spite of the seeming conceptual simplicity, the architecture in Fig. 1 is characterized by several electrical issues especially in terms of power quality and protection/safety issues such as (i) dangerous touch voltages occurring in the case of phase to ground fault, (ii) residual charge in the ship-to-shore cable, (iii) over-voltages and (iv) overcurrents. As far as the latter is concerned, the design of over-currents protection may become very complex due to the specific behavior of the frequency converter. Roughly speaking, the value of short circuit currents is highly reduced by the static converter impedance, so posing serious problems in guaranteeing a reliable and safety operation. Although a valid solution to the problem is investigated in [10] the innovative solution proposed in this paper is both able to make short circuit current much more detectable (enhancing their inherent value) and improve the power quality requirements. This is possible thanks to the deployment of an *ad hoc* control strategy for an advanced static var compensator which minimizes the harmonic content in current and voltage waveforms as well as the current unbalances. The paper is organized as follows. Section 2 introduces a literature review about power supply issues in seaports. Sections 3 and 4 present in detail the proposed novel power supply scheme for seaports and the related embedded control strategy. Section 5 reports some numerical results which demonstrate the feasibility and the validity of the designed High Voltage Shore Connection scheme and the well-operating of its constituting components (i.e. smart electrical interface). Sections 6 and 7 provide discussion and conclusions respectively.

## 2. Methods

In recent studies [11–13] the possibility to feed ships at berth with different technological solutions for the external power

supply has been discussed. Fuel cells on barge, LNG diesel engine, gas turbine powering alternators moved close to the quay by tractors and especially ship to shore connection have been considered as possible solutions. There is no doubt-as recognized by the relevant and more recent scientific literature [14,15] – that ship to shore connection is the most interesting and successful in terms of achievable general benefits (e.g. environmental and social). Nonetheless some open issues need to be addressed in order to make the ship to shore power supply solution technically feasible. The present paper gives therefore an important contribution by facing the most critical issues recognized by the scientific community [15–19] and by the specifically developed technical standards [20,21], namely the power quality and protection/safety issues. The design of cold ironing power system for enhancing electrical safety by including also special protection scheme have been addressed in [15]. This paper highlights how cold ironing applications are still embryonic and hence need to be researched. This has strongly motivated our efforts in conceptualizing a new ship to shore power supply solution that will be described in the Section 3. In [16], the authors examined mutual influences between high-voltage shore-connected ships and port earthing systems during phase-to-ground faults: in this case possible dangerous voltage gradients in sea water around the bonded ship hulls may occur. A similar contribution on grounding concern is given by Paul et al. in [17] where the technical basis for designing a resistance grounding method for a cold ironing project are established. A discussion about homo-polar grounding system for the ship on-board power system is here included. Paul and his co-workers, have enriched the related literature with two successive studies. In the first one [18], a review of the transient surge environment, transient overvoltage analysis and the application of metal-oxide surge arresters in shore-to-ship power supply system to enhance transient overvoltage protection and minimize equipment damage is provided. In the second one [19], to ensure safe and efficient operation of the cold-ironing systems, an implementation of a grounding switch key interlocked with an associated main disconnect switch and power plugs (for discharging quickly cable-capacitance voltage and charged energy to ground) is proposed. Another crucial protection/safety concern of the standard power supply solution in Fig. 1 is represented in the inability of the protection systems to sense the short circuit currents due to their reduced values. To overcome this concern Ion et al. shown in [10] how to increase the short-circuit current value by employing a capacitor bank, a conventional static var system – and a static compensator. In line with the outlined literature framework the present paper proposes of an innovative sustainable power supply solution in seaports and its related design and control. The innovative architecture, presented in the following Section 3, differs from the classical one in Fig. 1 for the presence of a smart electrical interface. The latter is basically formed by a rotating converter and an advanced static var system. The former provides the needed frequency conversion vessel/grid ensuring at the same time higher short circuit current values, higher reliability

and lower cost than the solution proposed in [10]. The latter provides to the innovative architecture an inherent robustness against potential on-board disturbances, i.e. fast load change, unbalances, harmonic currents so improving the quality of the power supplied as requested by [20,21]. This is possible thanks to the *ad hoc* designed smart interface control strategy introduced in the Section 4.

### 3. Theory

The proposed High Voltage Shore Connection scheme is shown in Fig. 2. Clearly, the main difference with the scheme of Fig. 1 relies on the smart electrical interface colored in blue: it consists in turn of a rotating converter and an advanced static var system.

The rotating converter is based upon the employment of an induction motor and a doubly-fed induction generator, whereas the excitation power supply is provided by an additional power source. The main difficulty in tailoring the whole system control strategy, presented in the sequel, relies on combining the various types of components or subsystems modeling and their various independent controls, while ensuring the stability of the overall system. In this connection, the aforementioned electrical machines constituting the rotating converter are modeled in terms of  $d$ - $q$  axes representation.

On the other hand, the advanced static converter is based upon a particular type of designed inverter whose modeling and control is addressed directly in terms of phase variables. In particular, in order to reduce the cost of the proposed innovative solution for ship-to-shore connections, the authors suggest to use a two-leg three-phase inverter which is here controlled according to sliding mode control technique. This kind of technique is recognized in the relevant literature as one of the appropriate way to control variable structure systems, as the inverter exactly is.

The scheme illustrated in Fig. 3 shows the control architecture as a whole. First of all the rotor voltage control is performed by using the inverter dc voltage changes. Therefore, when a fast load change occurs, the inverter supplies instantaneously the active and reactive power necessary to compensate the unbalance. This is essentially the role of a smart compensator device as the one here designed. Hence, the induction generator control acts in order to charge itself with the load variation. The amplitude of the rotor voltage is varied as a function of the dc voltage unbalance, while its phase is arranged in order to maximize the power factor of the induction generator. This last task is pursued through extremum seeking control.

The design of the proposed High Voltage Shore Connection control strategy is here addressed with a systemic point of view

and in order to guarantee significant improvements in terms of power quality and protection/safety issues. The designed architectural framework for High Voltage Shore Connection solution is quite complex in terms of involved devices and related control systems. No optimal (general) methodologies and hence consequent implementing techniques are specifically available in the relevant technical literature. In this framework, an adequate modeling of the smart interface components and the identification of control rules able to satisfy contemporaneously flexibility and the feasibility is essential. Therefore, our efforts were aimed at establishing some simple control laws strongly correlated to the fundamental relationships of active and reactive power exchanges among the components of the proposed smart electrical interface in High Voltage Shore Connection solution.

We will subsequently analyze the modeling and control of the smart electrical interface components: rotating converter and advanced static var system.

### 4. Calculation

#### 4.1. Rotating converter modeling and control

The need to adapt the frequency between vessel and grid has been pointed out in Section 1. The need to adapt the frequency of vessel and grid has been pointed out in Section 1. The main problem of static converter relies in the fact that it is impossible to deliver a fault current higher than the minimum threshold requested for the secure operation of the ship principal relay. In the light of a better detection of the short circuit currents, the designed smart electrical interface has been hence equipped with a rotating converter. A rotating converter offers remarkable advantages in comparison to the static converter, as far as cost, reliability and electromagnetic compatibility are concerned [22]. We will demonstrate that such a choice is advantageous also in terms of short circuit currents detection in ship-to-shore connections. As far as the rotating converter configurations are concerned, two main solutions can be considered: either a variable frequency synchronous-motor-generator [22] or an adjustable speed generators/motor based upon a doubly-fed induction machine [23,24].

The rotating converter in the designed smart electrical interface for High Voltage Shore Connection is based upon the use of an induction motor and a doubly-fed induction generator as in the second case mentioned. A new control law is hence proposed: the rotor voltages are controlled in a coordinated way with the advanced static var compensator. More specifically, the amplitude of the controlled rotor voltage depends on the charge state of the

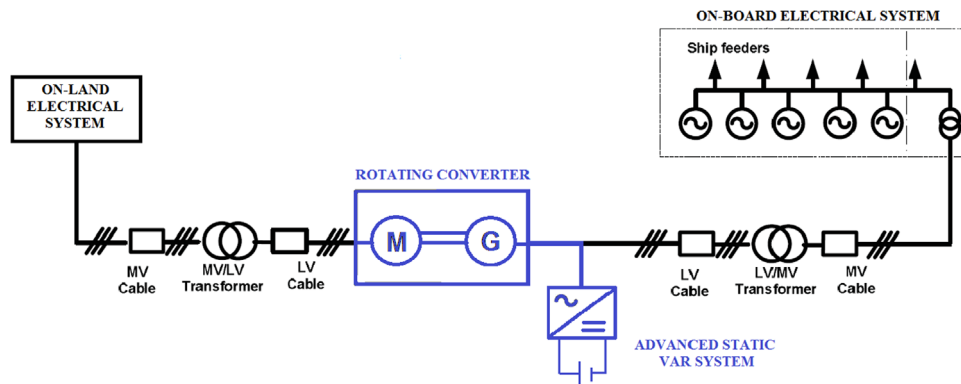

Fig. 2. High Voltage Shore Connection scheme with smart electric interface. (For interpretation of the references to color in this figure legend, the reader is referred to the web version of this article.)

inverter dc voltage while the phase angle is automatically adjusted in order to optimize the machine efficiency.

The considered model for the three phase induction machine is described in terms of  $d-q$  quantities as follows:

$$\begin{aligned} \bar{v}_s(t) &= r_s \bar{i}_s(t) + \left( \frac{p}{\Omega_n} + j \frac{\sigma \Omega(t)}{\Omega_n} \right) \bar{\psi}_s(t) \\ \bar{v}_r(t) &= r_r \bar{i}_r(t) + \left( \frac{p}{\Omega_n} + j \frac{\sigma \Omega(t)}{\Omega_n} \right) \bar{\psi}_r(t) \end{aligned} \quad (1)$$

$$c_e(t) = \frac{x_m}{x_r} \text{Im} \{ \bar{\psi}_r(t) \bar{i}_s(t) \}$$

where  $\sigma(t)$  is the motor slip and the linkages flux can be expressed as function of the stator and rotor currents in the manner that follows:

$$\begin{aligned} \bar{\psi}_s(t) &= x_s \bar{i}_s(t) + x_r \bar{i}_r(t) \\ \bar{\psi}_r(t) &= x_m \bar{i}_m(t) + x_r \bar{i}_r(t) \end{aligned} \quad (2)$$

The rotor voltage is equal to zero for the induction machine operating as motor. The modeling of the mechanical parts involves the coupling of the two rotors with the shaft. By neglecting the torsional oscillations and the shaft inertia, it is easy to show that the angular speed can be described by the following relationship:

$$\frac{d\Omega_r}{dt} = \frac{1}{T_{aeq}} c_{1e} P_{n1} p_1 \Omega_{n1} - D * \frac{\Omega_r}{\Omega_{r0}} + c_{2e} P_{n2} p_2 \Omega_{n2} \quad (3)$$

where  $T_{aeq}$  is the equivalent starting time of the group, i.e.:

$$T_{aeq} = T_{a1} \frac{P_{n1} p_1^2}{\Omega_{n1}^2} + T_{a2} \frac{P_{n2} p_2^2}{\Omega_{n2}^2} \quad (4)$$

In order to take into account the coupling of the induction machines with the static electrical components, it is more

convenient to recast the stator modeling in the following form:

$$\bar{v}_s(t) = \left[ r_s + j \frac{\Omega(t)}{\Omega_n} (x'_s + x_e) \right] \bar{i}_s(t) + \frac{x'_s}{\Omega_n} p \bar{i}_s(t) + \bar{e}(t) \quad (5)$$

where:

$$\bar{e}(t) = \frac{x_m}{x_r} \left( \frac{p}{\Omega_n} + j \frac{\sigma \Omega(t)}{\Omega_n} \right) \bar{\psi}_r(t) \quad (6)$$

and  $x_e$  is the external equivalent reactance, related to the transformer and cable etc.

By taking into account the scheme reported in Fig. 3, it is easy to argue that the stator voltage of the induction generator along the  $d-q$  axis can be directly expressed as function of ac inverter voltages  $v_a(t)$ ,  $v_b(t)$  and  $v_c(t)$ , since  $v_{sa}(t) = v_a(t)$ ,  $v_{sb}(t) = v_b(t)$  and  $v_{sc}(t) = v_c(t)$ :

$$\begin{bmatrix} v_{sd} \\ v_{sq} \end{bmatrix} = \sqrt{\frac{2}{3}} \begin{bmatrix} \cos \theta & \cos(\theta - \frac{2}{3}\pi) & \cos(\theta - \frac{4}{3}\pi) \\ -\sin \theta & -\sin(\theta - \frac{2}{3}\pi) & \sin(\theta - \frac{2}{3}\pi) \end{bmatrix} \begin{bmatrix} v_a \\ v_b \\ v_c \end{bmatrix} \quad (7)$$

The rotor voltage amplitude is regulated according to the scheme of Fig. 4a:

$$v_r(t) = k_p (v_c - V_{cref}) + k_i \int (v_c - V_{cref}) dt \quad (8)$$

In other words, when a load change occurs, the advanced static var compensator operates as flywheel with a very low time constant and successively the grid has the task of supplying the requested active power. The angle of the rotor voltage, as already mentioned, is arranged in order to meet the maximum efficiency of the generator machine. To this purpose, the algorithm based on the extremum seeking scheme proposed in [25] has been used due to its inherent degree of robustness.

The controller scheme for rotor voltage phase is shown in Fig. 4b. It uses a high pass filter (with a cutoff frequency,  $\omega_h$ ), a

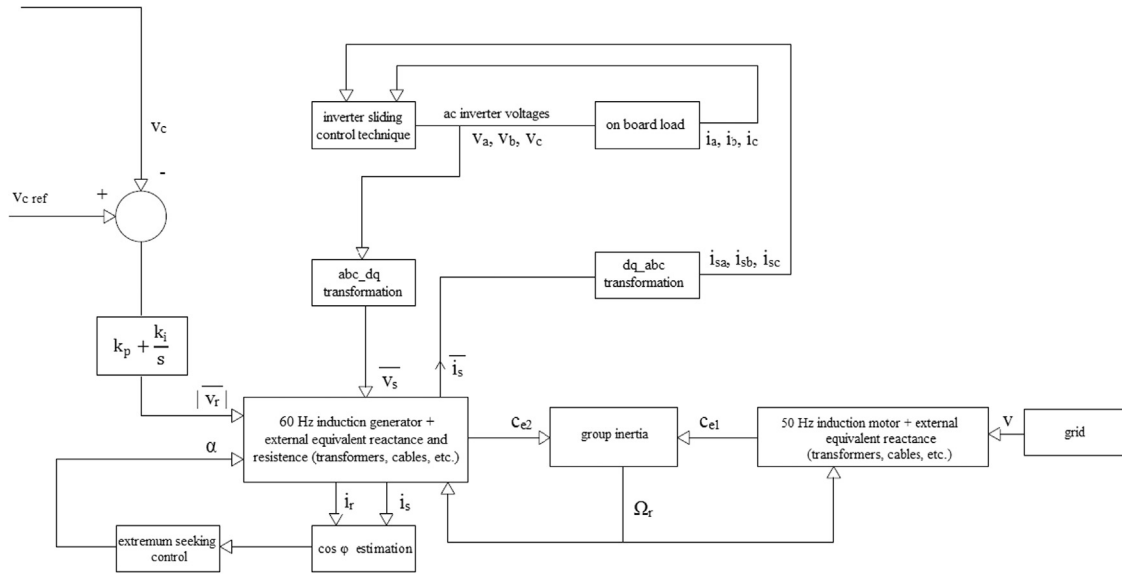

Fig. 3. Principle scheme of the whole High Voltage Shore Connection control strategy.

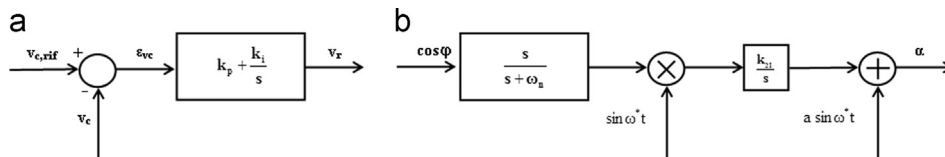

Fig. 4. (a) Control scheme of the rotor voltage amplitude. (b) Control scheme of the rotor voltage phase.

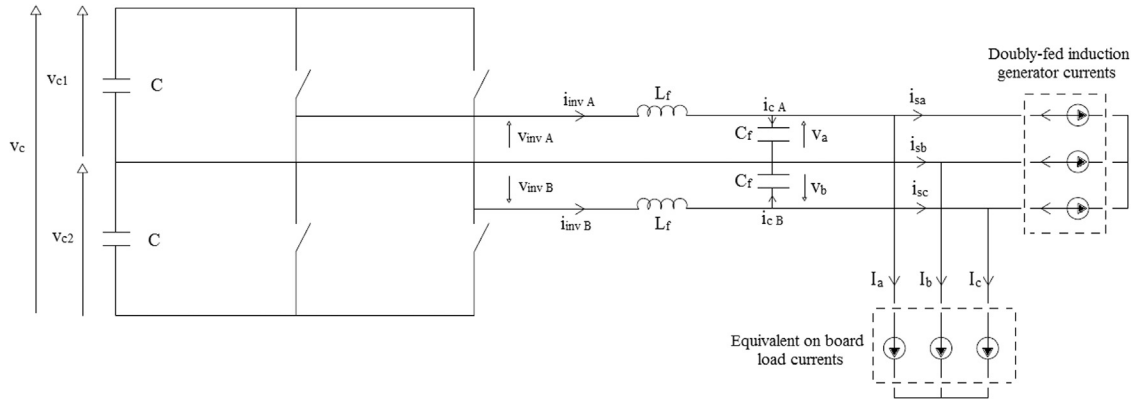

Fig. 5. Two-phase voltage controlled inverter.

demodulator, an integrator (with a suitable gain) and a compensator  $C(s)$ . A small-signal sinusoidal perturbation  $a \sin \omega^* t$  is associated to the integrator. In the present paper, the simplest form of the extremum seeking technique [26] has been adopted, with  $C(s)=1$  and  $\varphi=0$ .

#### 4.2. Advanced static var modeling and control

The conceptualized smart interface solution is in line with the modern tendency of using Flexible AC Transmission Systems which significantly improve the performance of electrical systems. In fact, the continuous fast development in power electronic technologies offers advanced devices representing actual and viable facilities for an adequate control of the electrical state variables and for giving to the system: (i) the desired degree of robustness, (ii) the required stability margins, (iii) the requested power quality and reliability levels. By equipping the smart electrical interface with an advanced static var compensator, the proposed High Voltage Shore Connection solution becomes much more competitive since the potential on-board disturbances, i.e. fast load change, unbalances, harmonic currents, can be significantly reduced by the prompt action of the included power electronic component.

By referring to the Fig. 5, that shows the proposed solution for the controlled inverter, the following dcac converter modeling holds:

$$\begin{cases} \frac{di_{invj}}{dt} = \frac{1}{L_j}(v_{invj} - v_j) \\ \frac{dv_j}{dt} = \frac{1}{C_j}(-i_{sj} + i_{invj} - i_j) \end{cases} \quad (9)$$

where the subscript indexes  $j, k \in \{A, B\}$  with  $j \neq k$ .

Furthermore, the dynamics of the dclink voltages can be stated as follows:

$$\begin{cases} \frac{dv_{c1}}{dt} = -\frac{1}{C_1}(u_A i_{invA} - u_B i_{invB}) \\ \frac{dv_{c2}}{dt} = \frac{1}{C_2}[(1 - u_A) i_{invA} - (1 - u_B) i_{invB}] \end{cases} \quad (10)$$

The reference quantities for the twophase system voltages and their corresponding derivatives can be expressed in compact way by defining the vector:

$$\mathbf{x}_{rj} = [x_{rj1}, x_{rj2}]^T \quad (11)$$

while the two components of  $\mathbf{x}_{rj}$  can be derived (for  $j=A,B$ ) as:

$$\begin{aligned} x_{rA1} &= -\sqrt{2}\omega V^{ref} \sin \omega t \\ x_{rA2} &= \sqrt{2}\omega V^{ref} \cos \omega t \\ x_{rB1} &= -\sqrt{2}\omega V^{ref} \sin(\omega t + \pi/3) \\ x_{rB2} &= \sqrt{2}\omega V^{ref} \cos(\omega t + \pi/3) \end{aligned} \quad (12)$$

The sinusoidal modeling of the inverter voltages can be rearranged in the standard matrix form:

$$\dot{\mathbf{x}}_{rj} = \mathbf{A}_r \mathbf{x}_{rj} \quad j = \{A, B\} \quad (13)$$

with:

$$\mathbf{A}_r = \begin{pmatrix} 0 & -\omega^2 \\ 1 & 0 \end{pmatrix} \quad (14)$$

By defining the statevariables vector  $\mathbf{x}_j$ :

$$\mathbf{x}_j = [x_{j1}, x_{j2}]^T = [v_{pj}, v_{pj}]^T \quad j = \{A, B\} \quad (15)$$

the vector  $\mathbf{x}_{ej}$  of the statevariables error can be directly expressed as:

$$\mathbf{x}_{ej} = \mathbf{x}_{rj} - \mathbf{x}_j = [x_{rj1} - x_{j1}, x_{rj2} - x_{j2}]^T \quad j = \{A, B\} \quad (16)$$

The following switching surface, which determines the change of the inverter configuration, is chosen according to [27], i.e. as a function of the statevariables error  $\mathbf{x}_{ej}$  and also of the dc voltages imbalance at the inverter input dc-link:

$$S_j(\mathbf{x}_{ej}, v_{c1}, v_{c2}) = \sigma_1 x_{ej1} + \sigma_2 x_{ej2} + \sigma_3 (\bar{v}_{c1} - \bar{v}_{c2}) + \sigma_4 (\bar{v}_{c1} - \bar{v}_{c2}) \quad (17)$$

This selection has been proven capable of counteracting the dc voltage imbalance, thus the use of a chopper action aimed at equalizing the dc voltage becomes superfluous.

For the control implementation, a convenient hysteresis band  $\Delta$  has to be identified as a function of the maximum allowable switching frequency and of the filter parameters. The control law takes the following form:

$$u_j = \begin{cases} 0 & \text{if } S_j(\mathbf{x}_{ej}, v_{c1}, v_{c2}) > +\Delta \\ 1 & \text{if } S_j(\mathbf{x}_{ej}, v_{c1}, v_{c2}) < -\Delta \end{cases} \quad (18)$$

where the subscript index  $j \in \{A, B\}$ .

Load current has been assumed as not perfectly sinusoidal and characterized by the addition of harmonics related to the fundamental one according to the expression:

$$I_{jh} = \frac{I_{j1}}{h} \quad j \in \{A, B\} \quad (19)$$

This allows to test the ability of the advanced static var compensator in compensating load current distortions.

## 5. Results

The performance of the smart electrical interface in the proposed High Voltage Shore Connection are assessed in a comprehensive dynamic simulation having the aim to perturb the system

**Table 1**  
Electrical parameters adopted in the dynamic simulation.

$k_p$	1
$k_I$	0.1
$r_s$ [p.u.]	0.05
$r_r$ [p.u.]	0.03
$x_s$ [p.u.]	3.08
$x_r$ [p.u.]	3.08
$x_m$ [p.u.]	3
$T_{a1}$ [s]	6
$T_{a2}$ [s]	6
$x_{e1}$ [p.u.]	0.1
$x_{e2}$ [p.u.]	0.1
$r_{e1}$ [p.u.]	0.01
$r_{e2}$ [p.u.]	0.01
$L_f$ [ $\mu$ H]	5
$C_f$ [ $\mu$ F]	50
$f_c$ [kHz]	3
$C$ [F]	0.01
$P_A$ [kW]	200
$P_B$ [kW]	200
$\cos \varphi_A$	0.8
$\cos \varphi_B$	0.8

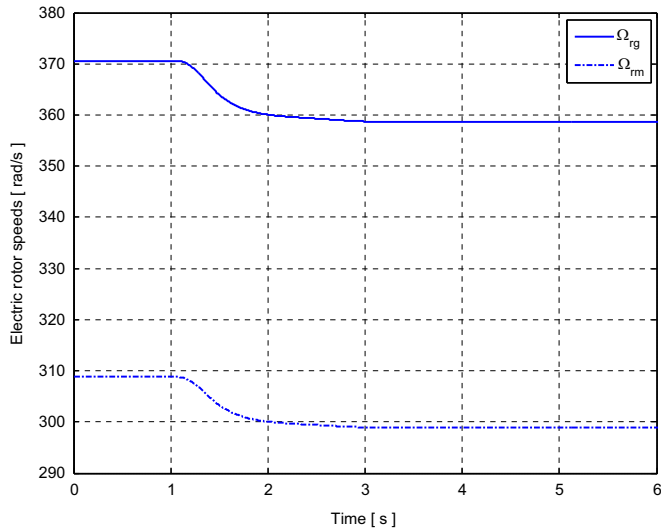

**Fig. 6.** Electrical rotor speeds (motor-generator) recorded during the dynamic simulation.

and hence test the level of robustness and the capacity the minimize the unbalances.

The parameters adopted in numerical simulations are reported in Table 1.

The electrical demand of the on-board electrical system is supposed to suddenly increase from 400 kW to 800 kW at the time instant  $t_0=1$  s. For testing the ability of the advanced static var compensator in improving power quality, the load is supposed to be shared as two distorted single phase loads.

In Fig. 6 the time behavior of the electrical rotor speeds for induction motor and doubly-fed induction generator are depicted.

The inverter dc voltage is shown in Fig. 7, where the fast change can be easily appreciated, even if the control action allows to restore the mean voltage profile at the dc nominal value. A detail about the dc voltage is included in the related main figure. In Fig. 8, whereas a detail of the dc capacitor voltages unbalance is depicted in correspondence of the load variation, it is clearly noticeable that the unbalance is dramatically reduced for the proper choice of the sliding surface (Fig. 9).

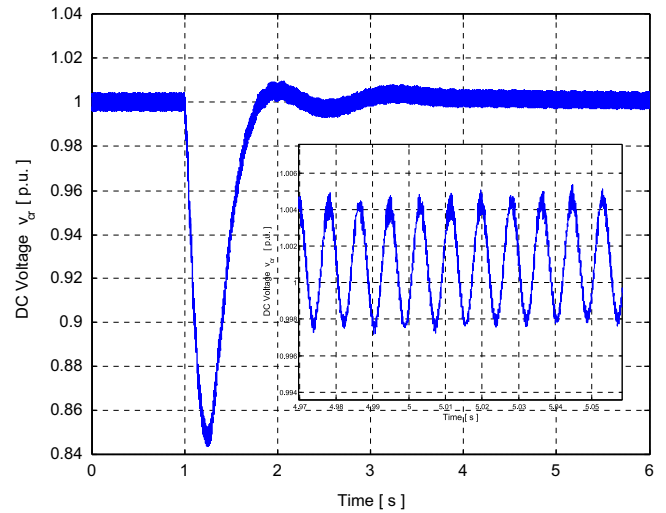

**Fig. 7.** DC inverter voltage recorded during the dynamic simulation.

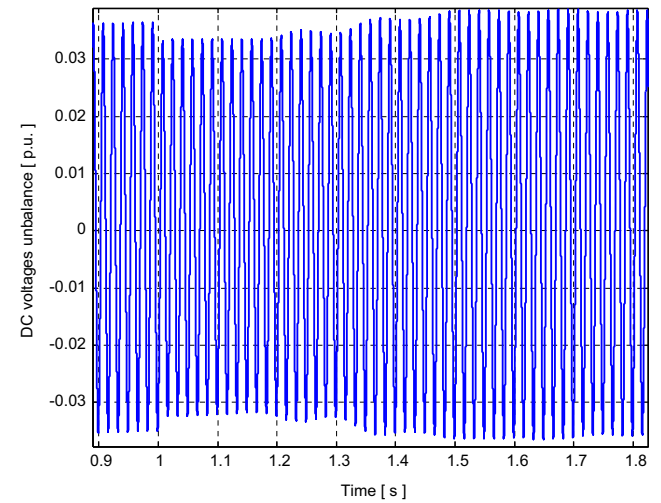

**Fig. 8.** DC capacitor voltages unbalances recorded during the dynamic simulation.

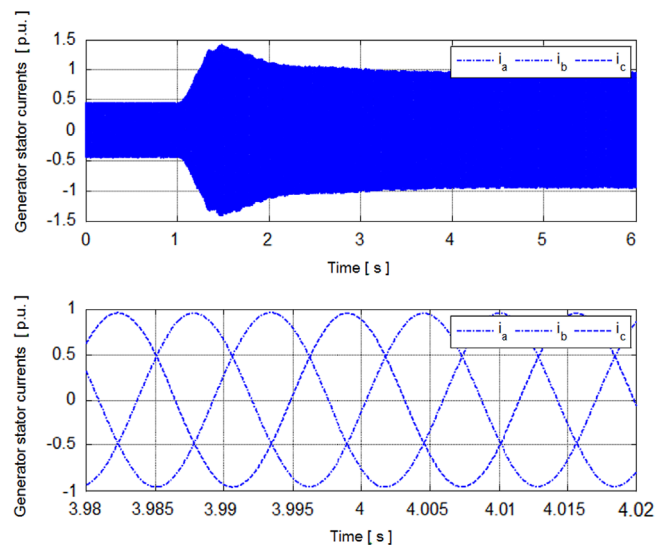

**Fig. 9.** Induction generator stator currents recorded during the dynamic simulation.

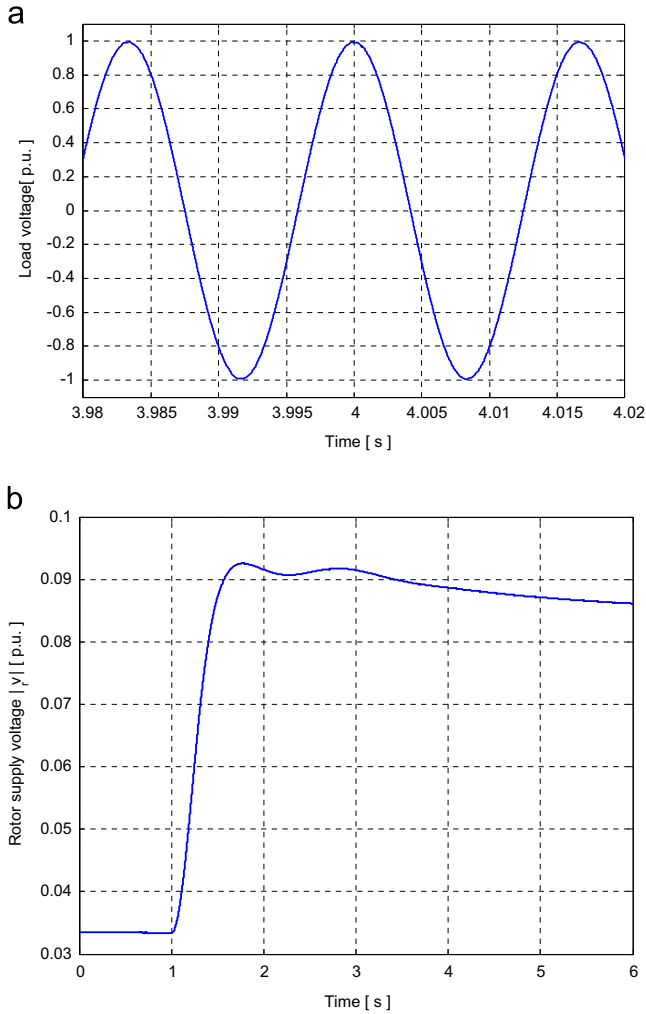

**Fig. 10.** (a) Load voltage recorded during the dynamic simulation. (b) Rotor voltage recorded during the dynamic simulation.

The advanced static var compensator integration in the proposed High Voltage Shore Connection scheme results in balanced induction generator currents against a high degree of load unbalance.

In Fig. 10a the load voltage is reported. It shows an inherently sinusoidal profile in spite of the distorted currents absorbed by the two single-phase non-linear loads.

In Fig. 10b the time behavior of the rotor voltage, which is controlled as function of the dc voltage change, is shown; while in Fig. 11 the power factor of the induction generator is reported, thus demonstrating the goodness of the extremum seeking control.

Fig. 12 shows the induction generator contribution to the total short circuit current. Remarkably, although it constitutes only a quote of the total short circuit current, it is already enough to ensure the correct action of the protection devices. The contribution of the advanced static var system, which must be limited in order to prevent the damage to the semiconductor devices, in any case will permit a more reliable operation of the overcurrents protection systems.

For the sake of comparison, the smart electrical interface has been replaced with the identified feasible solution for enhancing short circuit current value proposed in [10], exactly a classical static converter with a suitable static compensator. The ratio between the obtained average value of the short circuit currents

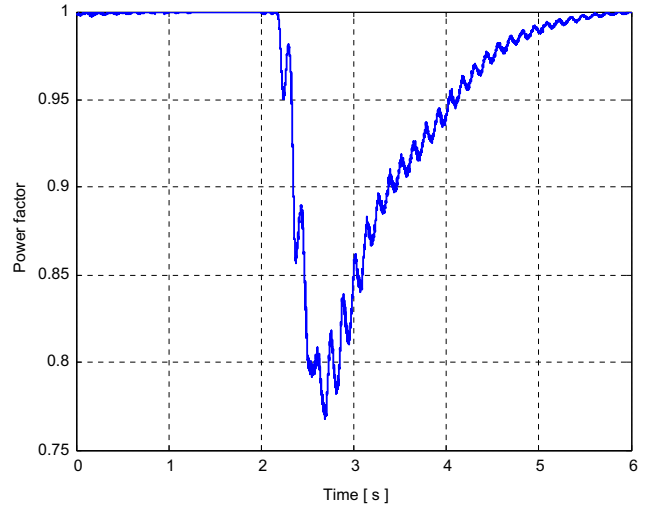

**Fig. 11.** Induction generator power factor recorded during the dynamic simulation.

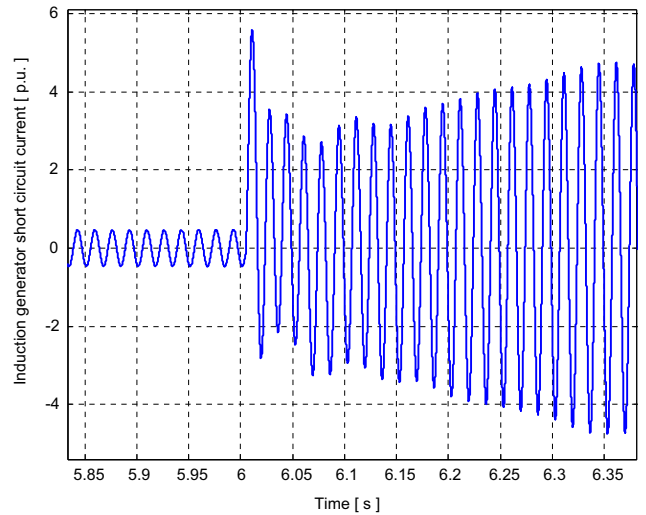

**Fig. 12.** Induction generator contribution to the total short circuit current recorded during the dynamic simulation.

**Table 2**  
High Voltage Shore Connection schemes comparison.

SCC ratio (SCCR)	Cost ratio	Reliability ratio
1.5 ÷ 2	0.58 ÷ 0.85	1.03 ÷ 1.25

provided by the respective grid frequency converters is:

$$SCCR = \frac{I_{GCF-ROT}}{I_{GCF-STAT}} \cong 1.5 \div 2 pu$$

where  $I_{GCF-ROT}$  is the induction generator short circuit current while  $I_{GCF-STAT}$  is the static converter short circuit current. Additional characteristics that could push the designers in choosing our proposed solution are the costs and the inherent reliability of the grid frequency converter as confirmed in [22–24]. The outcomes of the comparison can be quantitatively summarized in Table 2. The second and third column in Table 2 represent the cost and reliability ratio respectively. Like for SCCR, they express the ratio between the cost (reliability) between the proposed solution (i.e. High Voltage Shore Connection with smart electrical interface) and the classical one (i.e. High Voltage Shore Connection with static

converter and STATCOM). They confirm also the affordability and the dependability of the conceptualized power supply solution.

## 6. Discussion

The present paper provided an interesting power supply solution in seaports aimed at addressing specific power quality and protection/safety open issues while ensuring the emissions reduction and hence the sustainability of its implementation. The proposed solution is demonstrated as technically feasible, cost-effective and reliable, thus representing a viable and interesting alternative to be considered in cold ironing system projects.

## 7. Conclusions

The present paper tackled the issue of the design and control of a sustainable power supply system in seaports. A new smart electrical interface for High Voltage Shore Connection composed by two basic components is presented. First of all, a rotating converter instead of a classical static frequency converter for matching the difference of frequency between the on-land and the on-board electrical system. Then, an advanced static var system compensator to improve the quality of the power supplied has been envisaged. It has been demonstrated that the designed solution can: (i) enhance the short circuits level over the minimum intervention threshold of the protection systems (ii) improve the ship-to-shore connection robustness to counter potential on-board disturbances (i.e. fast load change, unbalances, harmonic currents and so on). The conceptualized control paradigm was found simple and efficient.

## References

- [1] European Commission. Communication from the commission-ports: An engine for growth-COM (2013) 295 final; 2014.
- [2] Committee on the Marine Transportation System. Marine transportation system performance measures executive summary; 2015.
- [3] Borkowski T, Tarnapowicz D. Shore to ship system – an alternative. *Electric power supply in port*. J KONES Powertrain Transp 2012;19(3):49–58.
- [4] Acciaro M, Ghiara H, Cusano MI. Energy management in seaports: a new role for port authorities. *Energy Policy* 2014;71:4–12.
- [5] Motiva services Ltd. Fact-finding study on opportunities to enhance the energy efficiency and environmental impacts of ports in the Baltic Sea Region; 2014.
- [6] Tarnapowicz D. Synchronization of national grid network with the electricity ships network in the "shore to ship" system. *Manag Syst Prod Eng* 2013; 3(11):9–13.
- [7] Khersonsky Y, Islam M, Peterson K. Challenges of connecting shipboard marine systems to medium voltage shoreside electrical power. *Ind Appl IEEE Trans* 2007;43(3):838–44.
- [8] Tamapowicz D. Synchronization of national grid network with the electricity ships network in the "shore to ship" system. *Manag Syst Prod Eng* 2013;11(9):13–2013;11:13.
- [9] Megdiche M, Radu D, Jeannot R. Protection plan and safety issues in the shore connection applications. In: Proceedings of the Electricity Distribution and International Conference and Exhibition. Stockholm, Sweden. 2013.
- [10] Ion M, Megdiche M, Radu D, Bacha S, Hadbi D. Increasing the short-circuit current in a shore connection system. In: Proceedings of the PowerTech, Grenoble, France; 2013. p. 1–6.
- [11] Battistelli L, Coppola T, Fantauzzi M, Quaranta F. Evaluation of the environmental impact of harbour activities: problem analysis and possible solutions. In: Rizzuto E, Soares C Guedes, editors. Sustainable maritime transportation and exploitation of sea resources. London: Taylor & Francis Group; 2012. p. 281–304.
- [12] Coppola T, Quaranta F. Fuel saving and reduction of emission in ports with cold ironing applications. In: Proceedings of the high speed marine vehicle conference, Naples, Italy; 2014. p.1–10.
- [13] Battistelli L, Coppola T, Fantauzzi M, Quaranta F. The environmental impact of cruise ships in the port of naples: analysis of the pollution level and possible solutions. *J Marit. Res* 2012;9(3):81–6.
- [14] Sciberras EA, Zahawi B, Atkinson DJ. Electrical characteristics of cold ironing energy supply for berthed ships. *Trans Res Part D: Transp Environ* 2015;39: 31–43.
- [15] Paul D, Peterson K, Chavdarian PR. Designing cold ironing power systems: electrical safety during ship berthing. *IEEE Ind Appl Mag* 2014;20(3):24–32.
- [16] Sulligoi G, Bosich D, Da Rin A, Tosato F. An examination of mutual influences between high-voltage shore-connected ships and port earthing systems during phase-to-ground faults. *IEEE Trans Ind Appl* 2012;48(5):1731–8.
- [17] Paul D, Chavdarian PB. A closer look at the grounding of shore-to-ship power supply system. In: Proceedings of the IEEE industrial & commercial power systems technical conference. Calgary, Canada; 2009. p. 1–7.
- [18] Paul D, Haddadian V. Transient overvoltage protection of shore-to-ship power supply system. *IEEE Trans Ind Appl* 2011;47(3):1193–200.
- [19] Paul D, Chavdarian PR, Haddadian V. Cable-capacitance discharge time with and without the application of grounding device. *IEEE Trans Ind Appl* 2011; 47(1):286–91.
- [20] IEC/ISO/IEEE. Utility Connections in Port, Part 1: High voltage shore connection (HVSC) systems – general requirements, 80005-1, Part 1: High Voltage Shore Connection (HVSC) systems – general requirements. Geneva: IEC/ISO/IEEE; 2012.
- [21] IEEE. IEEE recommended practice and requirements for harmonic control in electric power systems, IEEE Std 519™-2014. IEEE, New York. International Electrotechnical Commission, 2014. Utility connections in port – Part 3: Low Voltage Shore Connection (LVSC) Systems-- general requirements. IEC PAS 80005-3. Geneva: IEC; 2014.
- [22] Wang X, Chai J, Zhan J. Research on parallel operation characteristics of variable frequency synchronous-motor-generator (SMG). In: proceedings of the international conference on electrical machines and systems. Nanjing, China; 2005. p. 72–75.
- [23] Sae-Kok W, Yokoyama A, Ogawa S, Verma SC. Nonlinear excitation control for rotary type frequency converter using two sets of adjustable speed generators/ motors. In: Proceedings of IEEE/PES Asia Pacific transmission and distribution conference and exhibition. Yokohama, Japan; 2002. p. 195–200.
- [24] Hu K, Yokoyama R, Koyanagi K. Modeling and dynamic simulations of new rotary frequency converter which consists of doubly-fed machine and induction machine. In: IEEE Proceedings of power engineering society winter meeting. Singapore, Singapore; 2000. p. 411–415.
- [25] Krstic M. Performance improvement and limitations in extremum seeking control. *Syst Control Lett* 2000;39(5):313326.
- [26] Dan ZZ, Huo Hai B, Jian ZX, Yi CG, Yuan R. Adaptive maximum power point tracking control of fuel cell power plants. *J Power Sources* 2008;176(1): 259–269.
- [27] Lauria D, Coppola M. Design and control of an advanced PV inverter. *Sol Energy* 2014;110:533–42.