

Effect of Ultraviolet Irradiation on Proton Transfer Facilitated by 5,10,15,20-Tetraphenyl-21*H*,23*H*-porphine and Its Metal Complexes at a Water/1,2-Dichloroethane Interface

Tomoya KUBO, Manaki ASHIDA, Shiori OTAGIRI, Haruka NOZUE, Souma MAKIGAKI, and Teruo HINOUE[†]

Department of Chemistry, Faculty of Science, Shinshu University, Matsumoto, Nagano 390-8621, Japan

We examined photochemical effects by ultraviolet irradiation on facilitated proton transfer at a water/1,2-dichloroethane (W/DCE) interface by ion-transfer voltammetry using a Xe flash lamp. 5,10,15,20-Tetraphenyl-21*H*,23*H*-porphine (H₂TPP) or its metal complex, such as cobalt (Co(II)TPP), zinc (Zn(II)TPP), and nickel (Ni(II)TPP) complexes, was added into the DCE phase as an ionophore for the facilitated proton transfer. After we irradiated the W/DCE interface through the W phase, the voltammetric waves for proton transfer facilitated by H₂TPP and Co(II)TPP were remarkably enhanced and shifted to the lower potential region, compared to those before irradiation. We confirmed from the pH and argentometric titrations that such enhancements and shifts of the waves were caused by hydrogen chloride (HCl) produced by photodecomposition of DCE. On the other hand, the waves for proton transfer facilitated by Zn(II)TPP and Ni(II)TPP were very small from the beginning, and showed neither enhancement nor any shift upon irradiation.

Keywords 5,10,15,20-Tetraphenyl-21*H*,23*H*-porphine, H₂TPP, Co(II)TPP, Zn(II)TPP, Ni(II)TPP, water/1,2-dichloroethane interface, ion transfer voltammetry, facilitated proton transfer, ultraviolet light, photodecomposition

(Received July 21, 2017; Accepted September 4, 2017; Published December 10, 2017)

Introduction

In the past couple of decades, ion-transfer voltammetry at an interface between two immiscible electrolyte solutions (ITIES) has been used for examining various chemical and biochemical reactions occurring at a liquid-liquid interface and in a membrane.¹⁻⁴ In these many studies on ion-transfer voltammetry at ITIES, photochemistry, photosynthesis, photochemical reactions, and photoinduced electron transfer have been examined.⁵⁻¹² On the other hand, we have developed several voltammetric techniques at ITIES by using light as optical excitation sources. Thermal modulation voltammetry (TMV) is one of them, in which ultraviolet or visible laser light serves as a heat source. Using the TMV at ITIES, we determined the standard entropy changes of ion transfer for tetraalkylammonium ions, 1-alkylpyridinium ions, *etc.*¹³⁻¹⁵ Further, using ultraviolet light inducing photochemical reactions, we developed photomodulation voltammetry (PMV) and examined the photodecomposition of tetraphenylborate at ITIES with a He-Cd laser emitting light at 325 nm.^{16,17} Based on these studies, we attempted to use shorter wavelength ultraviolet light, since such light has a strong possibility to induce various photochemical reactions useful for analytical chemistry. This work is the first result for our attempt.

In general, we cannot observe ion transfers across ITIES of proton (H⁺) and very hydrophilic metal ions, such as Li⁺, Na⁺, *etc.*, from the aqueous to the organic phase within a conventional potential window by ion-transfer voltammetry. However, the

addition of proper ionophores, such as various kinds of crown compounds, to the organic phase allows one to observe the ion transfers of such hydrophilic ions.¹⁸⁻²⁰ Some lipophilic amines can facilitate proton transfer from the aqueous to organic phase by forming its conjugated acid.²¹⁻²³ 5,10,15,20-Tetraphenyl-21*H*,23*H*-porphine (H₂TPP) and its transition-metal complexes (M(II)TPP), which are lipophilic, have two proton-free nitrogen atoms in their pyrrole rings, as shown in Fig. 1, and consequently they can facilitate proton transfer from the aqueous to the organic phase at liquid-liquid interfaces.²⁴⁻²⁷ While exploring the PMV using ultraviolet light from a Xe flash lamp, we accidentally found out that proton transfer facilitated by H₂TPP or Co(II)TPP was greatly enhanced at a water/1,2-dichloroethane (W/DCE) interface after irradiating the interface. In this paper, we consider this enhancement in more detail and propose its mechanism.

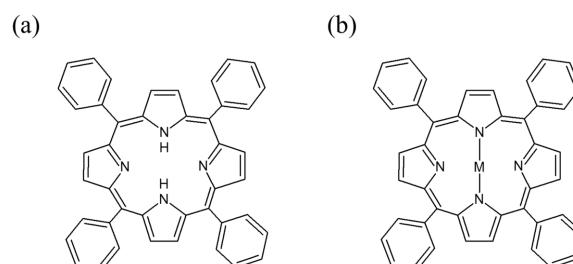

Fig. 1 Structures of H₂TPP (a) and MTPP (M = Co(II), Zn(II), or Ni(II)) (b).

[†] To whom correspondence should be addressed.
E-mail: thinoue@shinshu-u.ac.jp

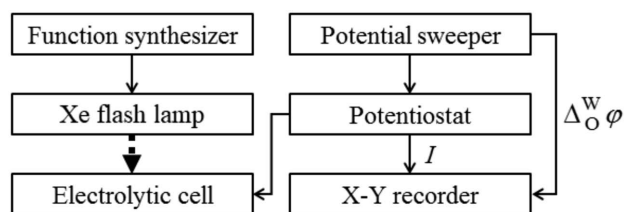

Fig. 2 Experimental arrangement for ion transfer voltammetry with a Xe flash lamp used in this work.

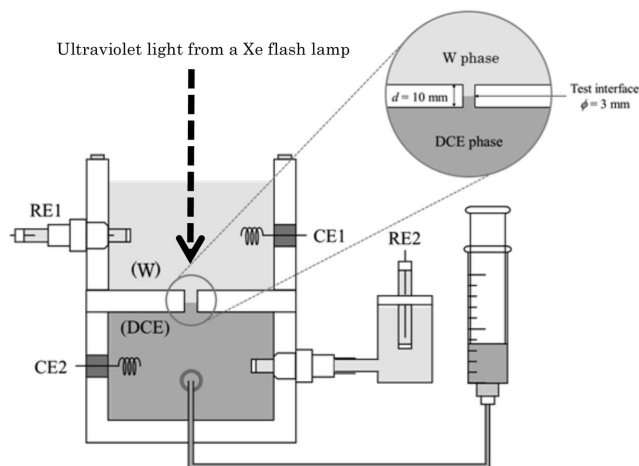
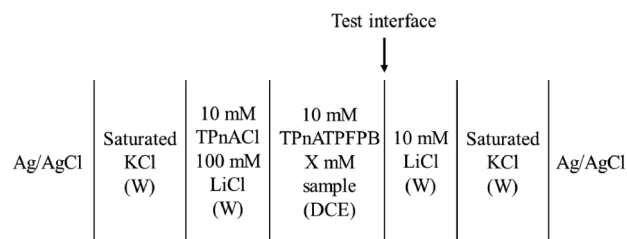

Fig. 3 Electrolytic cell used in this work. RE1 and RE2 represent KCl saturated Ag/AgCl reference electrodes and CE1 and CE2 represent spiral platinum-wire counter electrodes.

Experimental

Apparatus

Experimental arrangement for ion-transfer voltammetry at a W/DCE interface used in this work is shown in Fig. 2. Ultraviolet light was supplied from a Xe flash lamp (Hamamatsu, SQ type, L 2359) covered with UV glass driven at 400 Hz with an electronic source (Hamamatsu, C3684) and a function synthesizer (NF, 1930A). The Xe flash lamp has a spectral range from 185 to 2000 nm and several bright lines below an absorption edge of DCE saturated with water, approximately 300 nm. The irradiance at 229 nm is the strongest one in those at the wavelengths of the bright lines, $0.72 \mu\text{W cm}^{-2} \text{nm}^{-1}$.²⁸ For voltammetric measurements, we used a four-electrode type potentiostat (Hokuto Denko, HA1010mM1A); the voltammograms were recorded on an X-Y recorder (Riken Denshi Co., Ltd., Model-F35CA). The potential was usually swept at 10 mV s^{-1} with a potential sweeper (Huso Electro Chemical System, Model 1104). The positive currents indicate ion transfer of a cation from the W to the DCE phase and *vice versa*. The electrolytic cell used is shown in Fig. 3. The cell was machined from polychlorotrifluoroethylene resin blocks and consisted of two compartments for the W and DCE phases. The two compartments were separated by a quartz glass plate of 10 mm thick with a hole of 3 mm in diameter. The W/DCE interface was formed in the hole and its horizontal position was exactly fixed at the middle of the hole by injecting the DCE solution with a syringe. In order to maintain the interface flat, the wall of the hole on the side of the DCE phase was treated



Scheme 1

with dimethyldichlorosilane. The spot size of the ultraviolet light was approximately 10 mm in diameter at the interface, and the flashes were delivered from the W to the DCE phase. The reference electrodes in the W (RE1) and DCE (RE2) phases were KCl saturated silver/silver chloride (Ag/AgCl) electrodes. Spiral platinum wires were used as counter electrodes (CE1 and CE2). As shown in Scheme 1, the W phase contained 10 mM ($1 \text{ M} = 1 \text{ mol dm}^{-3}$) LiCl as a supporting electrolyte, whereas the DCE phase contained 10 mM tetrapentylammonium tetrakis(pentafluorophenyl)borate (TPnATFPFB) and X mM (usually 0.5 mM) H_2TPP , Co(II)TPP , Zn(II)TPP , or Ni(II)TPP . Cyclic voltammograms were measured after irradiation for 10 min. Ohmic drop compensation was used in all voltammetric measurements. The measurements were carried out at room temperature, $25 \pm 1 \text{ C}^\circ$. Galvani potential differences ($\Delta\phi^{\text{W}}$) were shown based on the tetraarsonium-tetrapentylborate assumption by taking the standard ion transfer potential ($\Delta\phi^{\text{W}}$) for tetraethylammonium ion at a W/DCE interface to be 20 mV .²⁹

Cyclic voltammograms were measured for the W phases with different proton concentrations. The proton concentration was adjusted with hydrochloric acid and sodium hydroxide solution. The chloride-ion concentration was adjusted to be 100 mM by adding LiCl or NaCl. Further, we measured the voltammograms, using phosphate and acetate buffer solutions with an ionic strength of 0.2 M. The pHs of W phases were measured with a pH meter (HORIBA, F-52S). In addition, UV-Vis absorption spectra were measured with a spectrophotometer (JASCO Co., V-670DS).

Acid-base titration and argentometry³⁰

Titration was carried out to determine photodecomposed products of DCE, that is, proton and chloride ion. Then, a 50-mL portion of DCE and 50 mL of deionized water were added to a 100-mL beaker, which was irradiated with a flash lamp for 180 min from the aqueous phase. After irradiation, we slowly stirred the aqueous phase with a glass rod to make it uniform, sampled a certain volume of the aqueous phase, and determined the proton concentration by acid-base titration and the chloride-ion concentration by argentometric titration (Mohr method).

Reagents

5,10,15,20-Tetraphenyl-21*H*,23*H*-porphine (H_2TPP), 5,10,15,20-tetraphenyl-21*H*,23*H*-porphine cobalt(II) (Co(II)TPP), 5,10,15,20-tetraphenyl-21*H*,23*H*-porphine zinc(II) (Zn(II)TPP), and 5,10,15,20-tetraphenyl-21*H*,23*H*-porphine nickel(II) (Ni(II)TPP) were purchased from Aldrich. Lithium tetrakis(pentafluorophenyl)borate (LiTPFPB) ethyl ether complex was purchased from Tokyo Chemical Industry. TPnATFPFB was synthesized by mixing tetrapentylammonium bromide and LiTPFPB ethyl ether complex in water/methanol mixed solution ($v/v = 1/2$).

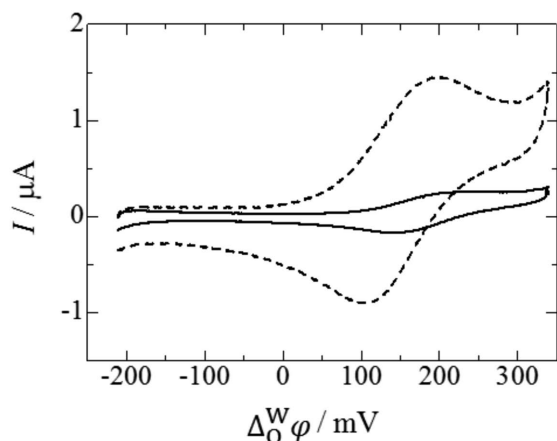

Fig. 4 Effect of ultraviolet irradiation with the Xe flash lamp on cyclic voltammograms for proton-transfer facilitated by H_2TPP . The solid curve is the voltammogram measured before the irradiation. The dashed curve is the voltammogram measured after the 10-min irradiation. The W phase contained 10 mM LiCl and the DCE phase 0.5 mM H_2TPP and 10 mM TPnATPFPB. The potential was swept at 10 mVs^{-1} .

Table 1 Peak potentials, peak currents, and mid-potentials obtained from the cyclic voltammograms in Fig. 4^a

Irradiation time/min	$\Delta_O^W \phi_{pa}/\text{mV}$	$I_{pa}/\mu\text{A}$	$\Delta_O^W \phi_{pc}/\text{mV}$	$I_{pc}/\mu\text{A}$	$\Delta_O^W \phi_m/\text{mV}$
0	235	0.257	149	-0.166	192
10	191	1.45	105	-0.902	148

a. $\Delta_O^W \phi_{pa}$ and $\Delta_O^W \phi_{pc}$ are the peak potentials of the anodic and cathodic peaks, respectively. I_{pa} and I_{pc} are the peak currents of the anodic and cathodic peaks, respectively. $\Delta_O^W \phi_m$ denotes the mid-potential.

TPnATPFPB synthesized was recrystallized from acetone and was washed with water/methanol mixed solution several times.³¹ 1,2-Dichloroethane (nacalai tesque) was mixed with deionized water in a large flask together and stirred with a stirring bar for 3 h for equilibration. All other reagents used were guaranteed reagents and used without further purification.

Results and Discussion

Effect of ultraviolet irradiation with the Xe flash lamp on proton transfer facilitated by H_2TPP

Figure 4 shows cyclic voltammograms for facilitated proton transfer across the W/DCE interface before and after ultraviolet irradiation for 10 min. Irradiation for longer than 10 min hardly gave any further voltammogram change. Although both voltammograms showed a couple of positive and negative waves, their mid-potentials and peak currents were greatly different. The waves have already been reported to be due to proton transfer facilitated by H_2TPP , shown as $H_2TPP(\text{DCE}) + H^+(\text{W}) \rightleftharpoons H_3TPP^+(\text{DCE})$.^{24,26} Table 1 lists the peak-potentials, $\Delta_O^W \phi_p$, the peak currents, I_p , and the mid-potentials, $\Delta_O^W \phi_m$, obtained from the cyclic voltammograms in Fig. 4. The mid-potential was shifted from 192 to 148 mV and the peak currents were enhanced by approximately 5.5 times. The negative shift in the mid-potential and the enhancement in the peak current both suggest an increase in the proton concentration

Table 2 Concentrations of proton and chloride ion before and after ultraviolet irradiation^a

Sample	Irradiation time/min	$[H^+]/10^{-5} \text{ M}$	$[Cl^-]/10^{-5} \text{ M}$
DCE	0	0.224 ^b	0
DCE	180	94.6 ± 0.4	104 ± 1
DCE containing 10 mM TPnATPFPB	180	4.14 ± 0.16	3.76 ± 0.26

a. All titrations were repeated 3 times.

b. The proton concentration was estimated from pH.

on the W-phase side of the interface. For proton transfer facilitated by H_2TPP , the following expression has been proposed on the condition that the concentration of H^+ in the W phase is much higher than that of H_2TPP in the DCE phase,^{26,32}

$$\Delta_O^W \phi_{H^+}^{1/2} = \Delta_O^W \phi_{H^+}^{\circ'} + \frac{RT}{2F} \ln \left(\frac{D_L^{\text{DCE}}}{D_{LH^+}^{\text{DCE}}} \right) - \frac{2.303RT}{F} \text{p}K_a^{\text{DCE}} + \frac{2.303RT}{F} \text{p}H^{\text{W}}. \quad (1)$$

Here, $\Delta_O^W \phi_{H^+}^{1/2}$ is a half-wave potential and $\Delta_O^W \phi_{H^+}^{\circ'}$ is a formal potential for the proton transfer. D_L^{DCE} and $D_{LH^+}^{\text{DCE}}$ are diffusion coefficients of H_2TPP and H_3TPP^+ in DCE, respectively. $K_a^{\text{DCE}} (= (a_L^{\text{DCE}} a_{H^+}^{\text{DCE}})/a_{LH^+}^{\text{DCE}})$ is the acid-dissociation constant of H_3TPP^+ in the DCE phase and $\text{p}H^{\text{W}}$ is the pH in the W phase. As described later in detail, the mid-potential was shifted at approximately 60 mV/pH. Based on this fact, a decrease in the pH between before and after the irradiation was estimated to be 0.74. This decrease in the pH indicates that the proton concentration after irradiation increased by 5.5-times higher than that before irradiation. The good agreement between the enhancement in the peak current and the increase in the proton concentration strongly suggests that DCE is decomposed by irradiation to produce hydrogen chloride, HCl. Indeed, it is known that DCE is slowly photodecomposed under sunlight, and that its decomposition is promoted by ultraviolet irradiation.^{33,34} From such facts, the following mechanism will be proposed. Hydrogen chloride is photochemically produced by the ultraviolet irradiation in the DCE phase, and is then extracted to the W phase. As a result, the facilitated proton transfer is greatly enhanced.

Determination of HCl produced by the ultraviolet irradiation

In order to experimentally demonstrate that DCE is decomposed by the irradiation to produce HCl, two kinds of titrations, that is, an acid-base and an argentometric titration, were carried out. Two DCE phases were tested. One is pure DCE and the other is a DCE solution containing 10 mM TPnATPFPB. The results are summarized in Table 2. These results indicate that the proton and chloride ion were almost equivalently produced by the irradiation, and it is therefore suggested that the decomposed product of DCE was mainly HCl. However, the concentration of the chloride ion was somewhat higher than that of the proton. This fact implies that the decomposed product was not only HCl, but also substances other than HCl, for example, choline Cl_2 . On the other hand, the addition of 10 mM TPnATPFPB into the DCE phase lowered both concentrations of proton and chloride ion. This fact implies that tetrakis(pentafluorophenyl)borate (TPFPB^-) strongly absorbed the ultraviolet light, or it was mainly

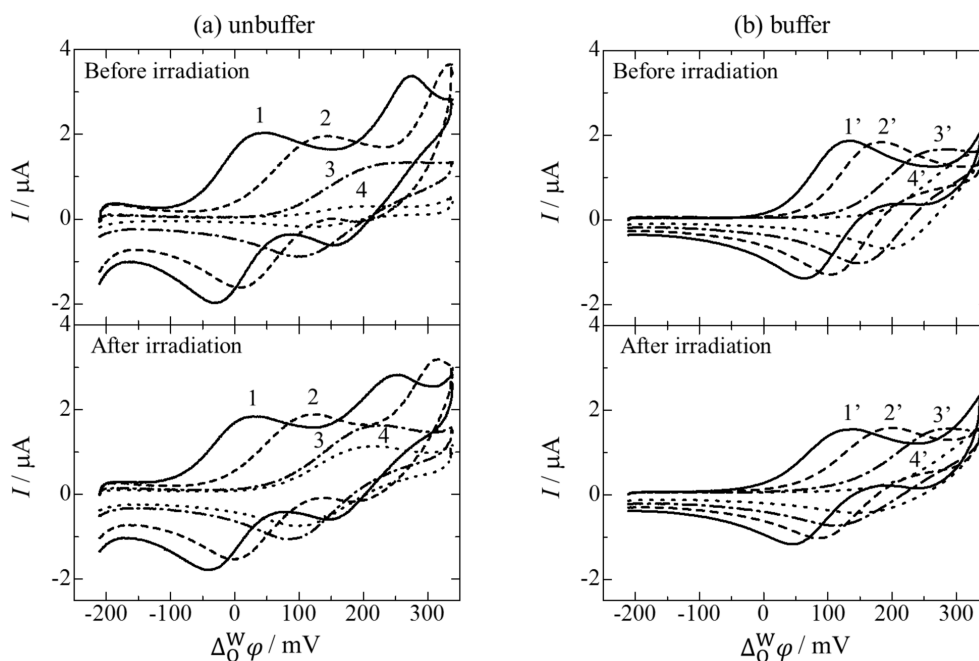

Fig. 5 Effect of the buffer action on the cyclic voltammogram for proton transfer facilitated by H_2TPP . (a) The voltammograms measured with unbuffer solutions. 1, pH 1.00; 2, pH 1.90; 3, pH 3.92; 4, pH 5.07. (b) The voltammograms measured with buffer solutions. 1', pH 2.57; 2', pH 3.42; 3', pH 4.43; 4', pH 5.37. The potential was swept at 10 mV s^{-1} .

decomposed instead of DCE by the irradiation, although TPFPB^- is known to be a resistive material to ultraviolet light.

Cyclic voltammetry by using unbuffer and buffer solutions as the W phase

In voltammetric measurements until now, the W phase was not buffered (pH 8.1). If buffer solutions are used for the W phase, the buffer action is expected to reduce any pH change with HCl distributed to the W-phase side of the interface. Based on this expectation, we measured cyclic voltammograms, using buffer solutions. Figures 5 and 6 show cyclic voltammograms obtained before and after the 10-min irradiation when using unbuffer (a) and buffer solutions (b), and the pH dependences of the mid-potentials and the anodic peak currents, respectively.

1) *Unbuffer solutions.* As can be seen in Fig. 5(a), the voltammograms measured before the irradiation showed two waves at pHs of 1.00 and 1.90, and one wave at pHs of 3.92 and 5.07. This is obvious that the two waves were both shifted to the more positive potential region with increasing pH, and eventually only the first wave remained within the potential window and the second wave was beyond it at higher pHs. The first and second waves are assigned to proton transfer facilitated by H_2TPP expressed as:

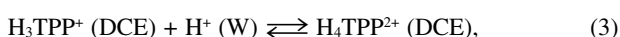
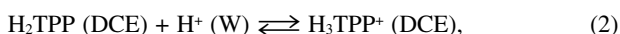

respectively.^{26,27} The pH dependences of $\Delta_0^W\phi_m$ in Fig. 6(a) show that the mid-potential of the first wave before and after the irradiation was shifted to more positive potentials with increasing pH, approximately at 60 mV/pH in the pH region less than 4 and leveled off in the pH region more than 4. The pH dependences of less than 4 can be explained by proton transfer facilitated by H_2TPP , as expressed by Eq. (2). However, it

should be noted that each mid-potential of the first wave after the irradiation was approximately 15 mV more negative than that before irradiation at the same pH. This fact means that the proton concentration on the W-phase side of the interface was slightly increased by HCl produced from photodecomposition of DCE. The levelling off in the pH region of more than 4 can be explained by a fact that the concentration of HCl did not become much higher than that of H_2TPP under such an irradiation condition.³² By the way, we have confirmed the existence of $\text{H}_4\text{TPP}^{2+}$ from a maximum absorption wavelength of the Soret band and the number of Q-band of an absorption spectrum of DCE solution of H_2TPP measured after ultraviolet irradiation.³⁵ Meanwhile, the voltammograms measured after irradiation showed two waves at lower pHs, and one wave at higher pHs in the same way as those before irradiation. Further, the wave was clearly observed even at pH 5.07 compared to that before irradiation. In addition, the pH dependence of I_{pa} in Fig. 6(a) shows that the wave was clearly observed even until pH 8.3 beyond pH 5.07 after the irradiation. These results are due to a fact that HCl, being produced from photodecomposition of DCE, maintained pH on the W-phase side of the interface constant at approximately 5 under the irradiation used in this experiment. Even before irradiation, the wave was slightly observed in a pH region of more than 5, as can be seen from the pH dependence on I_{pa} , although I_{pa} became rapidly smaller beyond pH 4. Moreover, the pH dependence on $\Delta_0^W\phi_m$ showed that $\Delta_0^W\phi_m$ was kept approximately constant at 170 mV regardless of the pH. Such pH dependences on I_{pa} and $\Delta_0^W\phi_m$ seem to be contradictory to each other. We speculate that this contradictory might be due to a fact that the pH at a thin W-layer adjacent to the interface had been lowered from the beginning by residual acid contained in DCE. With respect to the second wave, the mid-potentials before and after irradiation were shifted to positive potentials with increasing pH at approximately 60 mV/pH , although the second wave was measured at only two

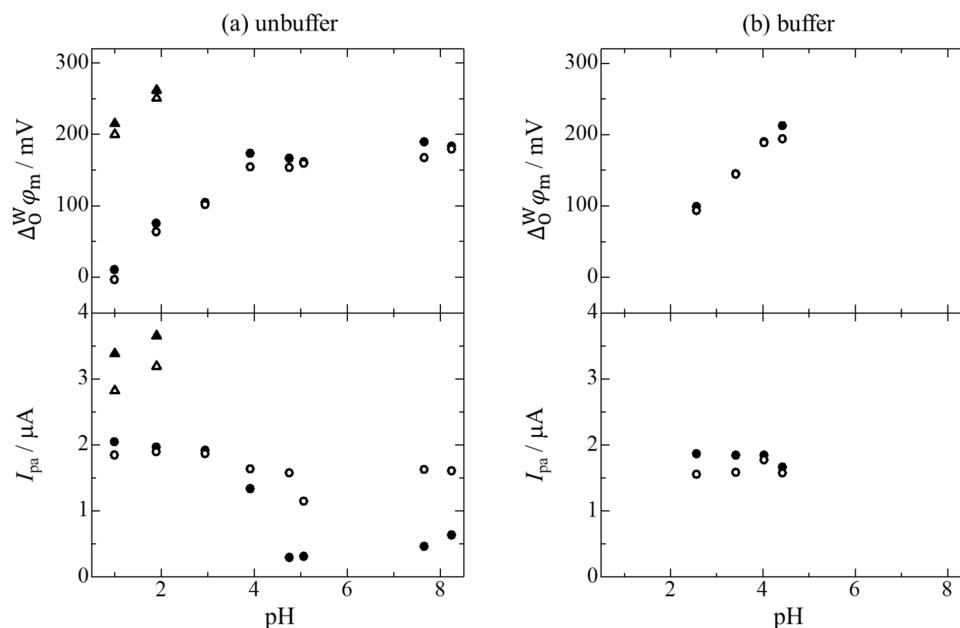

Fig. 6 pH dependences of the mid-potential, $\Delta_0^W\phi_m$, and the anodic peak current, I_{pa} , obtained from the cyclic voltammograms in Fig. 5. The solid circles, \bullet and the circles, \circ indicate $\Delta_0^W\phi_m$ and I_{pa} obtained from the first waves of the voltammograms measured before and after the 10-min ultraviolet irradiation, respectively. The solid triangles, \blacktriangle and the triangles, \triangle from the second waves of the voltammograms measured before and after the irradiation, respectively.

pHs of 1.00 and 1.90. This fact supports that proton transfer facilitated by H_2TPP occurred with one proton, as shown in Eq. (3). The irradiation effect on the second wave was also similar to that on the first wave.

2) *Buffer solutions.* When buffer solutions were used, both voltammograms before and after irradiation showed only one wave, as shown in Fig. 5(b), which corresponds to the first wave shown in Eq. (2). As can be seen from the pH dependences on $\Delta_0^W\phi_m$ and I_{pa} in Fig. 6(b), the mid-potentials agreed well before and after irradiation, although the peak currents were somewhat different. These facts suggest that the voltammograms before and after irradiation are substantially the same and that a change in pH coming from photodecomposition of DCE is entirely reduced by the buffer action. In this connection, pK_{a1} for H_4TPP^{2+} (DCE) $\rightleftharpoons H_3TPP^+$ (DCE) + H^+ (DCE) and pK_{a2} for H_3TPP^+ (DCE) $\rightleftharpoons H_2TPP$ (DCE) + H^+ (DCE) were determined to be 6.54 and 10.4 by using Eq. (1), respectively. These pK_a values are fairly in agreement with literature values.²⁶ From a comparison between the voltammograms measured with unbuffer and buffer solutions, it is confirmed that the change of the voltammogram by irradiation is attributed to HCl produced from photodecomposition of DCE.

Effect of the ultraviolet irradiation on ion transfer voltammograms for Co(II)TPP and other M(II)TPPs

It has already been known that proton transfer is facilitated by transition-metal complexes including Co(II)TPP, Zn(II)TPP, and Ni(II)TPP in the same manner as H_2TPP .^{24,25} Figure 7 shows the cyclic voltammograms for Co(II)TPP with unbuffer (a) and buffer (b) solutions. As can be seen in this figure, the voltammograms measured with unbuffer solutions showed two waves in the pH region of less than at least 3.21 and one wave at higher pHs, both before and after irradiation. The slopes for the first and second waves were determined to be 47 and 37 mV/pH, respectively, in the pH region less than 4.82 (data not

shown). Although the slopes were less than the theoretical value of 59 mV/pH, these waves are likely assigned to proton transfer facilitated by Co(II)TPP expressed as:

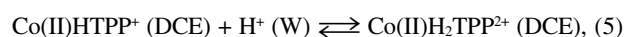
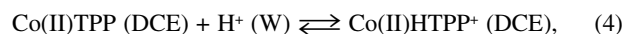

respectively.^{24,25} In addition, we confirmed the existence of Co(II)HTPP⁺ and Co(II)H₂TPP²⁺ from the maximum absorption wavelength of the Soret band and the number of Q-band in an absorption spectrum of DCE solution of Co(II)TPP after the ultraviolet irradiation.³⁵ Thus, the first wave was enhanced in the higher pH region by HCl produced from decomposition of DCE by the irradiation, compared to that before irradiation. On the other hand, the voltammograms measured with buffer solutions, shown in Fig. 7(b), showed only one wave, and both the voltammograms before and after irradiation were identical to each other. It is obvious from this fact shows that a change in the pH is perfectly vanished by the buffer action. In this connection, pK_{a1} for $H_2Co(II)TPP^{2+}$ (DCE) $\rightleftharpoons HCo(II)TPP^+$ (DCE) + H^+ (DCE) and pK_{a2} for $HCo(II)TPP^+$ (DCE) $\rightleftharpoons Co(II)TPP$ (DCE) + H^+ (DCE) were determined to be 6.54 and 10.2 by using Eq. (1), respectively. These pK_a values were almost the same as those for H_2TPP . On the other hand, the waves for proton transfer facilitated by Zn(II)TPP and Ni(II)TPP were very small from the beginning, and showed neither an enhancement nor a shift by the irradiation. Instead of an enhancement and a shift of the wave for the facilitated proton transfer for Zn(II)TPP, one new wave was observed after irradiation. Since the mid-potential of the new wave was almost constant regardless of the pH (data not shown), the wave is probably due to ion transfer from the DCE to the W phase of an anionic decomposed product of Zn(II)TPP by the irradiation. In the case of Ni(II)TPP, the effect of irradiation was hardly observed.

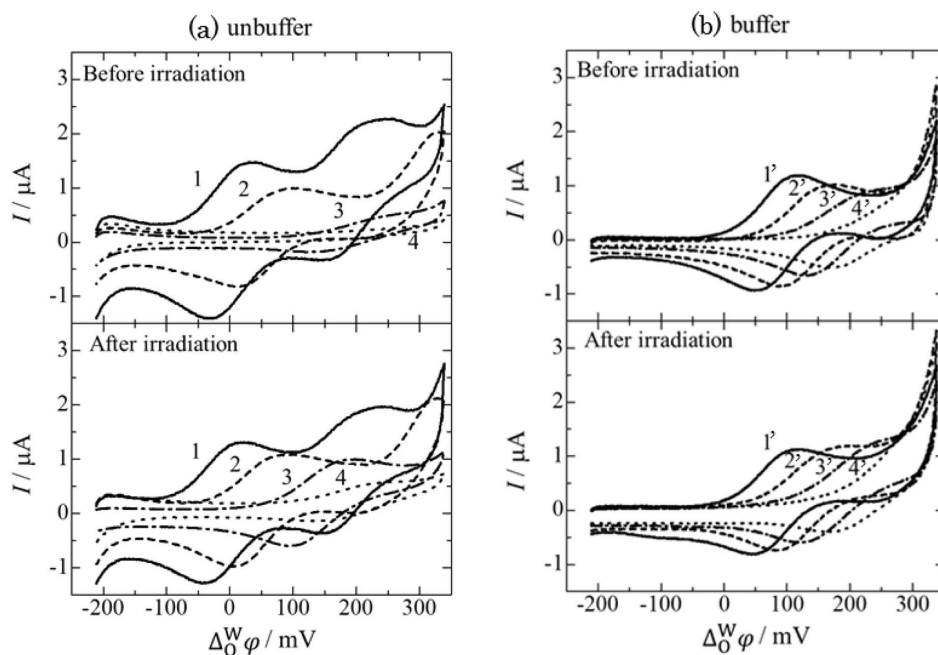

Fig. 7 Cyclic voltammograms for proton transfer facilitated by Co(II)TPP. (a) The voltammograms measured by using unbuffer solutions. 1, pH 0.91; 2, pH 3.21; 3, pH 5.89; 4, pH 8.39. (b) The voltammograms measured by using buffer solutions. 1', pH 2.65; 2', pH 3.45; 3', pH 4.55; 4', pH 5.56. The DCE phase contained 0.5 mM Co(II)TPP. The potential was swept at 10 mV s⁻¹.

Summary

We examined the effect of ultraviolet irradiation on proton transfers facilitated by H₂TPP and its transition-metal complexes at a DCE/W interface by ion transfer voltammetry, using a Xe flash lamp, which has several bright lines in the ultraviolet region below 300 nm, and acid-base and argentometric titrations. As the result, it became clear that DCE is decomposed by ultraviolet irradiation to produce HCl, and the HCl is distributed to the W phase to lower pH on the W-phase side of the interface. Consequently, when the W phase was not buffered, the voltammograms for proton transfer facilitated by H₂TPP were greatly changed. In addition to proton transfer by H₂TPP, we examined the effect of the irradiation on the proton transfer facilitated by Co(II)TPP and other metal complexes, such as Zn(II)TPP and Ni(II)TPP. For Co(II)TPP, the effect was the same as that for H₂TPP. However, one new wave was observed after irradiation for Zn(II)TPP when using either unbuffer or buffer solution. Since the wave was independent of the pH, it is probably due to ion transfer of a decomposed product of Zn(II)TPP by irradiation. With respect to Ni(II)TPP, the effect was hardly observed. The photodecomposition of DCE by irradiating with a Xe flash lamp with several bright lines below 300 nm is available for changing the pH *in situ* at a DCE/W interface.

References

- (a) J. Koryta, *Electrochim. Acta*, **1979**, *24*, 293. (b) J. Koryta, *Electrochim. Acta*, **1984**, *29*, 445. (c) J. Koryta, *Electrochim. Acta*, **1988**, *33*, 189.
- Z. Samec, *Chem. Rev.*, **1988**, *88*, 617.
- H. H. Girault and D. J. Schiffrin, "Electrochemistry of Liquid-Liquid Interfaces", ed. A. J. Bard, **1989**, Vol. 15, 1.
- M. Senda, T. Kakiuchi, and T. Osakai, *Electrochim. Acta*, **1991**, *36*, 253.
- Z. Samec, A. R. Brown, L. J. Yellowlees, H. H. Girault, and K. Baše, *J. Electroanal. Chem.*, **1989**, *259*, 309.
- V. Mareček, A. H. De Armond, and M. K. De Armond, *J. Electroanal. Chem.*, **1989**, *261*, 287.
- V. Mareček, A. H. De Armond, and M. K. De Armond, *J. Am. Chem. Soc.*, **1989**, *111*, 2561.
- N. A. Kotov and M. G. Kuzmin, *J. Electroanal. Chem.*, **1990**, *285*, 223.
- Z. Samec, A. R. Brown, L. J. Yellowlees, and H. H. Girault, *J. Electroanal. Chem.*, **1990**, *288*, 245.
- N. A. Kotov and M. G. Kuzmin, *J. Electroanal. Chem.*, **1992**, *338*, 99.
- D. J. Fermín, Z. Ding, H. D. Duong, P.-F. Brevet, and H. H. Girault, *J. Phys. Chem. B*, **1998**, *102*, 10334.
- H. Nagatani, S. Dejima, H. Hotta, T. Ozeki, and T. Osakai, *Anal. Sci.*, **2004**, *20*, 1575.
- T. Hinoue, E. Ikeda, S. Watariguchi, and Y. Kibune, *Anal. Chem.*, **2007**, *79*, 291.
- S. Furuhashi, Y. Terauchi, N. Makita, H. Tatsumi, and T. Hinoue, *Anal. Chem.*, **2010**, *82*, 6717.
- R. Watanabe, Y. Terauchi, M. Sakaue, and T. Hinoue, *Anal. Sci.*, **2014**, *30*, 595.
- S. Watariguchi, E. Ikeda, and T. Hinoue, *Anal. Sci.*, **2005**, *21*, 1233.
- S. Watariguchi, Y. Kibune, and T. Hinoue, *Anal. Sci.*, **2007**, *23*, 1143.
- D. Homolka, K. Holub, and V. Mareček, *J. Electroanal. Chem.*, **1982**, *138*, 29.
- Y. Shao, M. D. Osborne, and H. H. Girault, *J. Electroanal. Chem.*, **1991**, *318*, 101.
- E. Torralba, J. A. Ortuño, A. Molina, C. Serna, and F. Karimian, *Anal. Chim. Acta*, **2014**, *826*, 12.
- E. Makrlík, W. Ruth, and P. Vanýsek, *Electrochim. Acta*,

- 1983**, 28, 575.
22. D. Homolka, V. Mareček, and Z. Samec, *J. Electroanal. Chem.*, **1984**, 163, 159.
23. M. V. Manzanares and D. J. Schiffrin, *Electrochim. Acta*, **2004**, 49, 4651.
24. X. H. Xia, W. D. Su, and S. M. Zhou, *J. Electroanal. Chem.*, **1992**, 324, 59.
25. A. Trojánek, V. Mareček, H. Jänchenová, and Z. Samec, *Electrochem. Commun.*, **2007**, 9, 2185.
26. B. Su, F. Li, R. P.-Nia, C. Gros, J.-M. Barbe, Z. Samec, and H. H. Girault, *Chem. Commun.*, **2008**, 5037.
27. A. Trojánek, J. Langmaier, B. Su, H. H. Girault, and Z. Samec, *Electrochem. Commun.*, **2009**, 11, 1940.
28. Report on a Xe flash lamp by Hamamatsu Photonics K. K.
29. T. Osakai, “*Kagaku Binran, Kisohe*”, ed. Chemical Society of Japan, 5th ed., **2004**, Maruzen, II-579.
30. G. D. Christian, P. K. Dasgupta, and K. A. Schug, “*Analytical Chemistry*”, 7th ed. **2014**, Chaps. 8 and 11, John Wiley.
31. D. J. Fermín, H. D. Duong, Z. Ding, P.-F. Brevet, and H. H. Girault, *Phys. Chem. Chem. Phys.*, **1999**, 1, 1461.
32. H. Matsuda, Y. Yamada, K. Kanamori, Y. Kudo, and Y. Takeda, *Bull. Chem. Soc. Jpn.*, **1991**, 64, 1497.
33. D. Salomon, A. W. Kirk, and E. T.-Roux, *J. Phys. Chem.*, **1979**, 83, 2569.
34. T. Yano and E. T.-Roux, *J. Phys. Chem.*, **1980**, 84, 3372.
35. E. Austin and M. Gouterman, *Bioinorg. Chem.*, **1978**, 9, 281.
-