

# *A Screw Surface of a Board*

Makoto ICHIKAWA\*

(Received June, 29, 1967)

## 1. Introduction

As to how to make a screw surface of a board used in a screw conveyer and the like, two or three methods regarded as fit for a work shop are known wide, but in these methods, by reason of the fact that a helix curvature on a root cylinder, a flank angle etc., the important elements to a screw surface, are not taken into consideration, an outside diameter, a pitch and a flank angle cannot be made just as they are desired.

As is generally known, only an involute helicoid screw surface can be developed among the screw surfaces, and therefore its screw surface must be made of a board by taking advantage of the property. About such a way of thinking, for example, Dr. P. CORMAC shows that an involute helicoid screw may be constructed by cutting out two circular rings having a slit of a board, Fig. 1, being overlapped and stitched together round the outer circular edges and pulling apart it at the slits. But a method of making a screw surface of a board with requested dimensions seems not to be found yet.

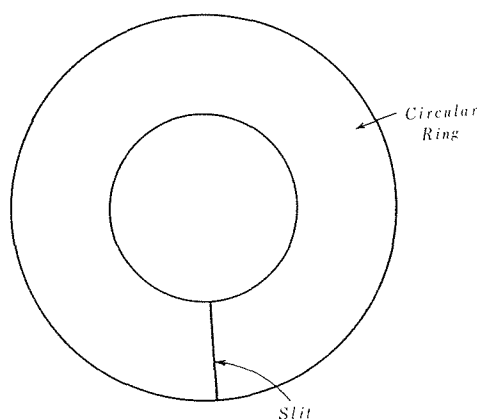

Fig. 1. Construction of Model of Involute Helicoid Screw shown by P. CORMAC.

\* Assistant Professor of Mechanical Engineering, Faculty of Engineering, Shinshu University.

The author, fully considering the specific property of an involute helicoid, has found out the theory of making a screw surface of an involute helicoid of a board, which led him to make one that has a dimension as accurate as desired. This method is not only useful in manufacturing a conveyer, pump and the like which need a screw surface but also convenient in both researching and teaching a screw thread and a gear, especially in the latter as a model of an involute helicoid, an involute worm, a gear hob etc. can be made easily and accurately.

## 2. Theory of Making

This theory, as is above mentioned, is to be derived from fact that an involute helicoid has a property of being developable and the developed one becomes a ring of two concentric circles, and therefore, it is a chief subject to decide the dimensions of the inner and outer diameter of the ring, in order to make a screw surface with requested dimensions.

Moreover, when we come to think that a pitch, a flank angle and an outside diameter change according to their mutual relation and in consequence, variant screw surfaces can be formed, in case of the inner circumferential edge of the ring being fitted around a shaft, it is well understood that a pitch, a flank angle, an outside diameter and a shaft diameter, namely a root diameter, are all the constructive elements of the screw surface. Even if the dimension of a ring has been decided to make a requested screw surface, the ring makes not only the particular requested one but also other variant ones infinitely within a certain limit.

### 2-1. Radius of Helix Curvature on Base Cylinder

The radius of a helix curvature on the base cylinder of an involute helicoid, is equal to that of the inner circle of the ring that the developed screw surface forms. The diameter and the lead angle of the helix on the base cylinder can be calculated from the given involute helicoid, so the radius of the helix curvature on the base cylinder must be obtained, in proceeding with this theory.

In Fig. 2, let  $r_g$  be the radius of the base cylinder of an involute helicoid. Let  $A_0$ ,  $A_1$  and  $A_2$  be the points where the helix and the tangents, that is, a generatrix of an involute helicoid, at  $Q_1$  and  $Q_2$  to the helix meet a perpendicular plane to axis,  $Q_1P_1$  and  $Q_2P_2$  the generatrix of the base cylinder at  $Q_1$  and  $Q_2$ ,  $M_1$  the intersection of the tangents to the helix at  $Q_1$  and  $Q_2$ ,  $M_2$  the intersection of the tangents to the base cylinder at  $P_1$  and  $P_2$ , respectively. And let  $\angle A_1M_1A_2 = d\theta'$ ,  $\angle A_1M_2A_2 = d\theta$  and let  $\beta_g$  be the lead angle

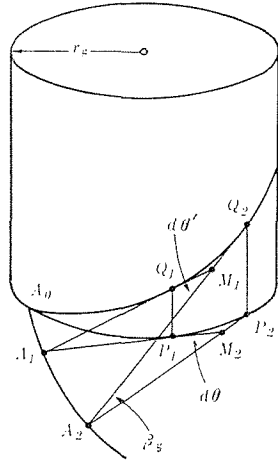

Fig. 2. Obtaining Radius of Helix Curvature on Cylinder.

of the helix, we have

$$d\theta = d\theta' \cdot \sec \beta_g. \tag{1}$$

Then, the angle subtended by  $\widehat{Q_1Q_2}$ , that is the helix, at the centre of the base cylinder becomes  $d\theta'$ , the radius of curvature  $\rho$  is given by

$$\rho = \frac{r_g \cdot d\theta \cdot \sec \beta_g}{d\theta'}. \tag{2}$$

From the two preceding equations, we get

$$\rho = r_g \cdot \sec^2 \beta_g. \tag{3}$$

The above is also the equation to obtain the radius of a common helix curvature.

### 2-2. Equations to Obtain the Dimensions

Of the involute helicoid screw surface,  $2r_a$  is the outside diameter,  $2r_b$  the root diameter,  $P$  the pitch and  $\alpha$  the flank angle at the mean diameter, respectively.

For the mean diameter  $2r_c$ , we have

$$2r_c = r_a + r_b, \tag{4}$$

the lead angle  $\beta_c$  at the mean diameter is given by

$$\tan \beta_c = \frac{P}{2\pi r_c}, \tag{5}$$

and from the property of an involute helicoid, for the lead angle  $\beta_g$  on the base cylinder, we have

$$\tan \beta_g = \sqrt{\tan^2 \alpha + \tan^2 \beta_c}. \tag{6}$$

From the preceding equations,  $\beta_g$  can be obtained, and so the radius  $r_g$  of the base cylinder is given by

$$r_g = \frac{P}{2\pi \cdot \tan \beta_g}. \tag{7}$$

Hence, for the radius  $R_g$  of curvature of helix on the base cylinder, from Eq. (3), we get

$$R_g = \frac{r_g}{\cos^2 \beta_g}. \tag{8}$$

Let  $S_1$  and  $S_2$  be the length of the generatrix from the point of contact to the root and to the top of an involute helicoid screw surface, respectively, we get

$$S_1 = \frac{\sqrt{r_b^2 - r_g^2}}{\cos \beta_g}, \quad (9)$$

$$S_2 = \frac{\sqrt{r_a^2 - r_g^2}}{\cos \beta_g}. \quad (10)$$

And then, let  $R_1$  and  $R_2$  be the distance from the centre of the helix curvature on the base cylinder to the root and the top of that screw surface, we get

$$R_1 = \frac{\sqrt{r_b^2 \cdot \cos^2 \beta_g + r_g^2 \cdot \sin^2 \beta_g}}{\cos^2 \beta_g}, \quad (11)$$

$$R_2 = \frac{\sqrt{r_a^2 \cdot \cos^2 \beta_g + r_g^2 \cdot \sin^2 \beta_g}}{\cos^2 \beta_g}. \quad (12)$$

For the length  $l$  of one coil of the helix on the base cylinder, we have

$$l = \frac{2\pi r_g}{\cos \beta_g}, \quad (13)$$

and let  $\theta$  (deg.) be the ratio of the length  $l$  to the circumferential length having the radius  $R_g$  of the helix curvature as its radius, we get

$$\theta = \frac{l}{2\pi R_g} \cdot 360 = \frac{r_g}{R_g \cdot \cos \beta_g} \cdot 360, \quad (14)$$

where  $\theta$  is the centre angle of the circle radius  $R_g$  which is needed to obtain one coil of the helix. Then the number  $n$  of the coils of the screw surface which can be made of a board, is given by

$$n = \frac{R_g \cdot \cos \beta_g}{r_g}. \quad (15)$$

### 2-3. Construction

The construction order is as follows (Fig. 3) :

Describe a circle of radius  $R_g$ . Decide two points on the circumference so that the angle subtended by them at centre may be  $\theta$ . Draw a tangent to the circle at each point and decide two points on either of the tangents having the distance of  $S_1$  and  $S_2$  from the point of contact, as shown in the

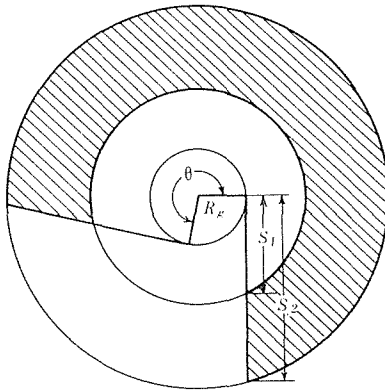

Fig. 3. Construction of Screw Surface of Board (1).

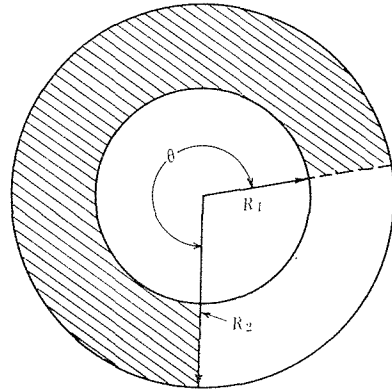

Fig. 4. Construction of Screw Surface of Board (2).

figure. Describe two concentric circles of which the radii have the distance covering from the centre to the points, respectively, and the part surrounded by the two circles and the two tangents (covered with oblique lines in the figure) makes the screw surface of one coil.

The inner circumferential edge forms the root and the outer forms the top of the screw surface, and the tangents make the generatrix of the involute helicoid. Therefore, if the inner circumferential edge is fitted to the helix having a requested pitch on the shaft of which the diameter is equal to the requested root diameter, the outside diameter and the flank angle are to have requested value naturally, that is, the desired screw surface is to be obtained.

Moreover, the two concentric circles can be described by  $R_1$  and  $R_2$  from Eq. (11) and (12), but in this case, it is easy to describe but troublesome to calculate and the generatrix of an involute helicoid cannot be seen, as shown in Fig. 4.

The number of boards which are needful to make as many coils of the screw surface as number  $N$ , if the overlaps be ignored, is given by  $N/n$  and the fraction must be calculated as one board. In this case, the angle  $\theta$  of the board, from Eq. (14), is given by

$$\theta = \frac{r_g}{R_g \cdot \cos \beta_g} \cdot 360 \cdot (\text{fraction}). \tag{16}$$

### 3. Example of Calculation and Models

Data are as follows :

Outside diameter	$2r_a = 150$ mm,
Root diameter	$2r_b = 58$ mm,
Pitch	$P = 52$ mm,
Flank angle	$\alpha = 30^\circ$ .

The lead angle  $\beta_c$  at the mean diameter, from Eq. (5) and (4), is given by

$$\tan \beta_c = \frac{P}{\pi(r_a + r_b)}, \quad (17)$$

substituting the data in above Eq. (17), we get

$$\tan \beta_c = \frac{52}{3.1416(75 + 29)} = 0.1592.$$

The lead angle  $\beta_g$  on the base cylinder is, by substituting above value and  $\tan 30^\circ = 0.5774$  in Eq. (6),

$$\tan \beta_g = \sqrt{0.5774^2 + 0.1592^2} = 0.5989,$$

hence

$$\beta_g = 30^\circ 55',$$

substituting above value in Eq. (7), the radius  $r_g$  of base cylinder is

$$r_g = \frac{52}{2 \times 3.1416 \times 0.5989} = 13.8192,$$

then, the radius of curvature  $R_g$  of the helix is, by substituting above value and  $\cos 30^\circ 55' = 0.8579$  in Eq. (8),

$$R_g = \frac{13.8192}{0.8579^2} = 18.78 \text{ (mm)}.$$

The centre angle  $\theta$  of the circle of the radius  $R_g$  necessary to obtain one coil of the screw surface, from Eq. (14), is

$$\theta = \frac{13.82}{18.78 \times 0.8579} \cdot 360 = 308.8 \text{ (deg.)},$$

the length  $S_1$  and  $S_2$  of the tangents to the circle of radius  $R_g$ , from Eq. (9) and (10), are

$$S_1 = \frac{\sqrt{29^2 - 13.82^2}}{0.86} = 29.72 \text{ (mm)},$$

$$S_2 = \frac{\sqrt{75^2 - 13.82^2}}{0.86} = 85.92 \text{ (mm)}.$$

The number of coils which can be obtained of a board, by substituting the preceding values in Eq. (15), is

$$n = \frac{18.78 \times 0.86}{13.82} = 1.17 \text{ (coils)}.$$

Using the values of  $R_g$ ,  $\theta$ ,  $S_1$  and  $S_2$  obtained by these manners, the requested screw surface can be made. The screw surface which is made by the above mentioned calculated value is shown in Photo-1. In making the

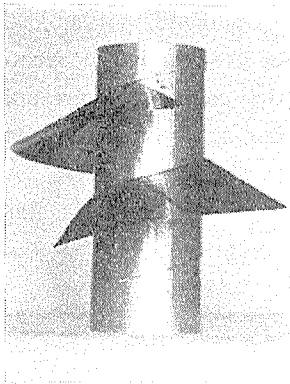

Photo. 1. Model of Screw Surface.

screw surface practically, the inner circumferential edge of the phosphor bronze plate ring 0.2 mm thick having above mentioned values was fitted around to the helix groove with requested pitch which is made on an aluminum cylinder, so that its bottom diameter might be equal to the requested root diameter. In this case, as the whole of the board was used without reference to  $\theta$ , about 1.2 coils of the screw surface were obtained as indicated in calculation, and moreover, a very accurate outside diameter and a flank

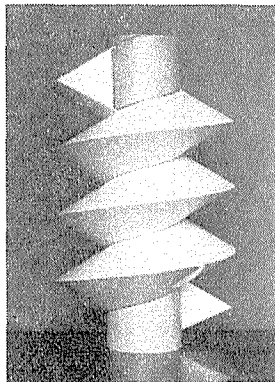

Photo. 2. Model of Involute Helicoid Screw Surface (1).

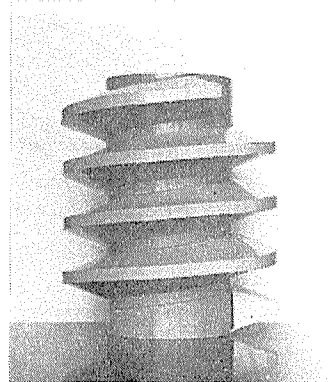

Photo. 3. Life-Size Model of Gear Hob, (Module 12, Pressure Angle  $20^\circ$ )

angle were obtained, too.

A model of an involute helicoid of 148 mm in outside diameter, 58 mm in root diameter, 52 mm in pitch,  $30^\circ$  in flank angle, is shown in Photo. 2. In making this screw surface, as three boards (six boards for both the flank) were used, about 3.5 coils were obtained. Although both the flanks of a screw surface are made by the same constructions, in the section, only an upper line indicates a generatrix of an involute helicoid, as shown in the photograph.

A life-size model of a gear hob; module 12, pressure angle  $20^\circ$ , is shown in Photo. 3.

In making these models (Photo. 2, 3 and 4), a pipe and a board of solid poly vinyl chloride are used as a material, for the shaft and the plate ring. The helix groove of the shaft is shaped by an angular fraise cutter so that it may have a section which is to be decided from the given pitch and flank angle. For example, when the model of the involute helicoid in Photo. 2 is made, the inner and the outer circumferential edges are shaped accurately by a lathe as shown in Fig. 5, considering both the cases of overlapping and pasting. The rings are connected with each other at the cut lines, and then one flank is formed by fitting the inner edge to the helix groove. And the other flank is formed by the same manner, and finally both the flanks are stucked together round the outer circumferential edges.

#### 4. Limit of Flank Angle

The flank angle of a screw surface which is used in a screw conveyer

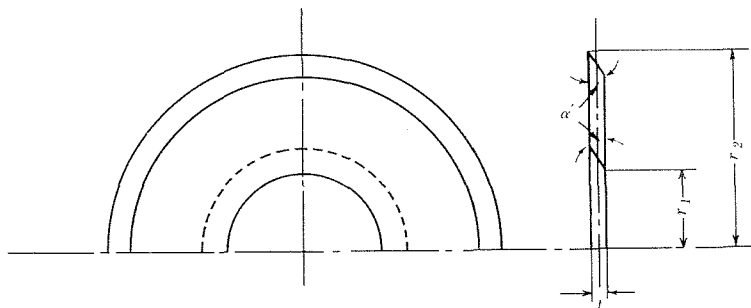

- $r_1$  = Radius of Inner Circle.  
 $r_2$  = Radius of Outer Circle.  
 $t$  = Thickness of Board.  
 $\alpha'$  = Flank Angle.

**Fig. 5. Form of Ring Edge.**



and the like, had better be made as small as possible, but in an involute helicoid, the diameter of a base cylinder cannot be larger than a root diameter, and so there will be found out a certain limit in the flank angle.

Substituting Eq. (6), representing the relation in an involute helicoid in Eq. (7), we get

$$r_g = \frac{P}{2\pi\sqrt{\tan^2\alpha + \tan^2\beta_c}}, \quad (18)$$

substituting Eq. (5) in the above equation, we get

$$r_g = \frac{r_c P}{\sqrt{4\pi^2 r_c^2 \tan^2\alpha + P^2}}. \quad (19)$$

From the property of an involute helicoid, we have

$$r_b \geq r_g, \quad (20)$$

from Eq. (19) and (20), we get

$$r_b \geq \frac{r_c P}{\sqrt{4\pi^2 r_c^2 \tan^2\alpha + P^2}}, \quad (21)$$

hence, the value of limit of a flank angle is given by

$$\tan\alpha \geq \frac{P\sqrt{r_c^2 - r_b^2}}{2\pi r_c r_b} \quad (22)$$

or

$$\tan\alpha \geq \frac{P\sqrt{r_a^2 + 2r_a r_b - 3r_b^2}}{2\pi r_b (r_a + r_b)}. \quad (23)$$

When the flank angle has the minimum value obtained by the preceding equation, from Eq. (19), we get  $r_g = r_b$ . That is, the diameter of the base cylinder is equal to the root diameter, and then from Eq. (9),  $S_1 = 0$  is obtained, and the construction is as shown in Fig. 6.

If the value of a flank angle becomes smaller than the limit value, a complete involute helicoid can not be formed, and therefore it is impossible to construct, too.

Obtaining the limit value of the flank angle in the example shown in Photo. 2, from Eq. (22), we get

$$\tan\alpha \geq \frac{52\sqrt{51.5^2 - 29^2}}{2 \times 3.1416 \times 51.5 \times 29} = 0.2358,$$

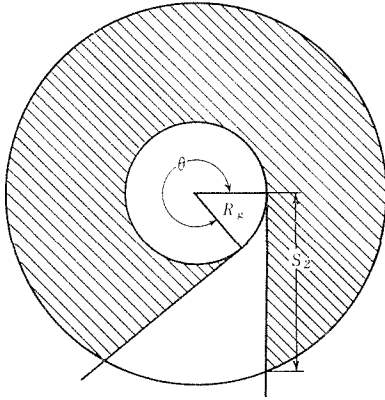

Fig. 6. Construction of Screw Surface of Board (3), in Case of Limit Flank Angle.

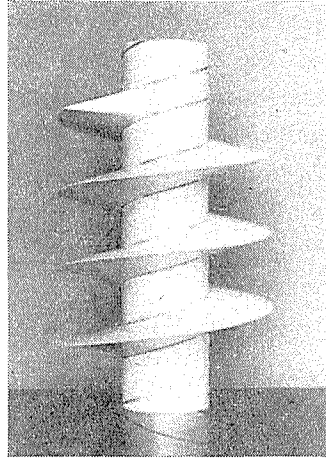

Photo. 4. Model of Involute Helicoid Screw Surface (2), in Case of Limit Flank Angle.

hence,

$$\alpha \geq 13^{\circ}16'.$$

The model of above data (148 mm outside diameter, 58 mm root diameter 52 mm pitch,  $13^{\circ}16'$  flank angle) is shown in Photo. 4. The generatrix of the involute helicoid is observed as the tangent to the root cylinder.

Moreover, let  $\beta_b$  be the lead angle on the root cylinder, we have

$$\tan \beta_b = \frac{P}{2\pi r_b} \quad (24)$$

and substituting above Eq. (24) in Eq. (23), we get

$$\tan \alpha \geq \tan \beta_b \frac{\sqrt{1 + 2\frac{r_b}{r_a} - 3\left(\frac{r_b}{r_a}\right)^2}}{1 + \frac{r_b}{r_a}}. \quad (25)$$

From Eq. (25),  $r_b/r_a$  being represented as an abscissa,  $\alpha$  as an ordinate and  $\beta_b$  as a parameter, the diagram shown in Fig. 7 is obtained. Therefore, when the outside diameter  $2r_a$ , the root diameter  $2r_b$  and the pitch  $P$  are given, the limit of a flank angle can be decided easily by using the diagram.

## 5. Conclusion

The following are stated in this paper :- the theory of making a screw surface of a board could be derived from a property of an involute helicoid

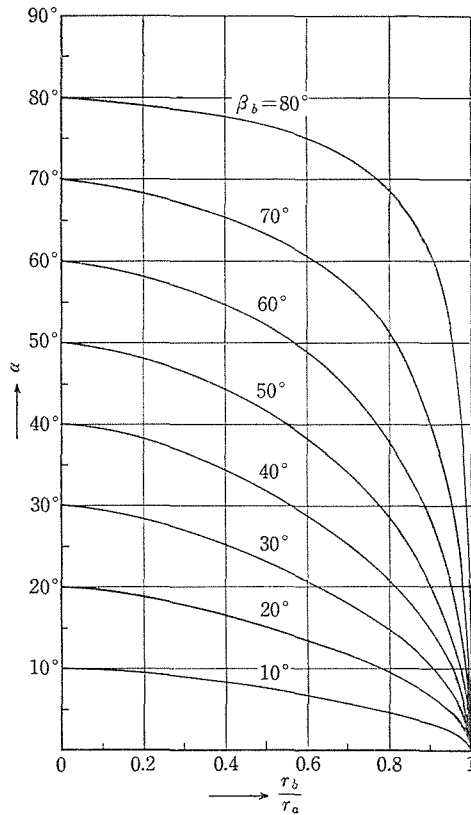

Fig. 7. Diagram of Limit Flank Angle.

and an desired one could be made accurately. In addition, the limit of the flank angle was discussed in making it practically.

The author believes at present that this is the only method of making an accurate screw surface of a board theoretically, since it is theoretically impossible to make that of the other triangular thread and the like of a board.

This method has the following advantageous points in comparison with some other methods for work shop.

- 1) The outside diameter, the pitch and the flank angle can be made as they are wished. In other words, a theoretically accurate screw surface can be made.
- 2) The flank angle which is not considered in other methods can be made into any angle that meets a purpose for use within a certain limit decided by the outside diameter, the root diameter and the pitch, on the basis of the property of an involute helicoid.

3) The number of coils of a screw surface which is made of one board can be calculated.

Moreover, for example, as a model can be made in case a generatrix coincides with a cutting off line of a board, and a diameter at a base cylinder is equal to a root diameter, this is convenient for learning the property of an involute helicoid.

#### Acknowledgement

The author wishes to express his gratitude for the guidance and encouragement received from Dr. Akira YAMAMOTO, Professor of the Research Laboratory of Precision Machinery and Electronics of the Tokyo Institute of Technology. He also is greatly indebted to Dr. Isamu YOSHIMOTO for his suggestions in writing this paper and to Dr. Muneharu MOROZUMI for his contribution to the author in making the model.

This paper first appeared in the Journal of the Society of Precision Engineering, Volume 32, No. 9, September 1966.

#### Reference

- 1) P. CORMAC : A Treatise on Screws and Worm Gear, their Mills and Hobs, Chapman & Hall Ltd, London, (1936) 40.

#### Summary

It seems that a theoretical and accurate method of making a screw surface of a board has not been known yet.

Considering the property of an involute helicoid, the author has derived the theory on how to make a screw surface of a board, and succeeded in making a very accurate one by using this theory. This method has many advantageous points in comparison with some other methods which are known as for a work shop.

Furthermore, the author thinks that this is only method of making an accurate screw surface of a board, since it is impossible theoretically to make that of a triangular thread and the like, of a board.