

Improvement in Efficiency of Wireless Power Transfer of Magnetic Resonant Coupling Using Magnetoplated Wire

Tsutomu Mizuno¹, Shintaro Yachi¹, Akira Kamiya¹, Daisuke Yamamoto¹

¹Faculty of Engineering, Shinshu University, Nagano 380-8553, Japan

Wireless power transfer is expected in the use of an electric vehicle and a chip card. However, it requires a high efficiency and takes a long distance. In this paper, we propose the use of a magnetoplated wire (MPW), which is a copper wire (COW) whose circumference is plated with a magnetic thin film, to improve transmission efficiency. The MPW can reduce resistances due to the proximity effect comparison with the COW. The inner diameter of COW and MPW coils is $d_i = 37$ mm and their number of turns is $n = 10$. As a result, the resistances of the COW and MPW at the frequency $f = 12$ MHz are 6.8Ω and 4.1Ω , respectively, which show a reduction of 40%. The quality factors of the COW and MPW at the frequency $f = 12$ MHz are 83 and 138, respectively, which show an increase of 66%. The efficiencies of the COW and MPW at a transmission distance of 10 mm are 69.8% and 77.7%, respectively, which show an increase of 7.9%.

Index Terms— wireless power transfer, magnetic resonant coupling, efficiency, magnetoplated wire, litz wire, quality factor.

I. INTRODUCTION

The technology of the wireless power transfer of magnetic resonant coupling has already been utilized, for example, in IC cards, and its practical application to portable telephones and electric automobiles is expected [1]. The wireless power transfer of magnetic resonant coupling takes a long distance and can be used in long-distance transmission with a high efficiency [2]. It is necessary to improve the quality factors of transmitting and receiving coils for long-distance and high-efficiency transmission. For the improvement in the quality factor characteristic, a litz wire is generally used to decrease the AC resistance due to the skin effect of a coil [3]. However, the decrease in AC resistance caused by the proximity effect is difficult, and there is a limit in increasing the quality factor using a litz wire.

Therefore, the authors propose the use of a litz wire (LMW) with a magnetoplated wire (MPW) to improve the transmission efficiency [4]. The MPW is a copper wire (COW) plated with a magnetic thin film. The MPW increases the inductance and decreases the AC resistance due to the proximity effect. This is because an alternating magnetic flux flows in the magnetic thin film with larger permeability and resistivity than copper. As a result, by the magnetic thin film, the inductance is increased, and the resistance due to the proximity effect is decreased because eddy current loss is reduced [5], [6].

In this paper, the impedance characteristics of coils using litz wires (LCWs) with COWs and LMWs are compared. In addition, the transmission efficiency characteristics of the LCW and LMW coils are compared, and the other following characteristics are described.

- (1) Impedance characteristics of the LCW and LMW coils
- (2) Transmission efficiency characteristics of the wireless power transfer of magnetic resonant coupling

II. WIRELESS POWER TRANSFER OF MAGNETIC RESONANT COUPLING USING MAGNETOPLATED WIRE

Fig. 1 shows the structures of the COW and MPW. The COW has a diameter of $100 \mu\text{m}$ and is plated with insulating films. The MPW is a copper wire with a diameter of $100 \mu\text{m}$ and is plated with magnetic thin films (Fe and Ni). The thicknesses of the Fe and Ni thin films are 0.9 and $0.05 \mu\text{m}$, respectively. The Ni film is plated for ease of soldering.

Fig. 2 shows the structures of the LCW and LMW. Each litz wire is composed of eight wires.

Fig. 3 shows the wireless power transfer of magnetic resonant

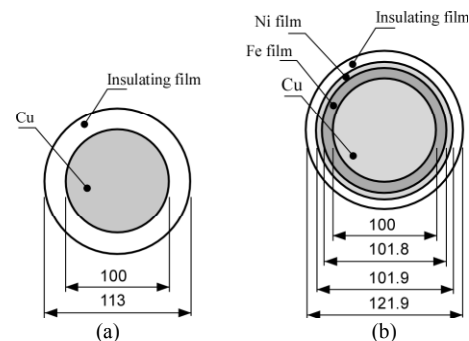

Fig. 1. Structures of COW and MPW (unit: μm). (a) COW. (b) MPW.

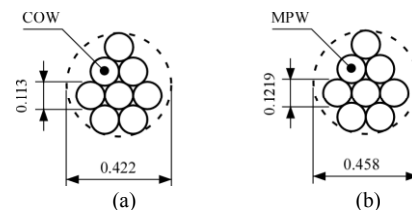

Fig. 2. Litz wires using COW and MPW (unit: mm). (a) LCW. (b) LMW.

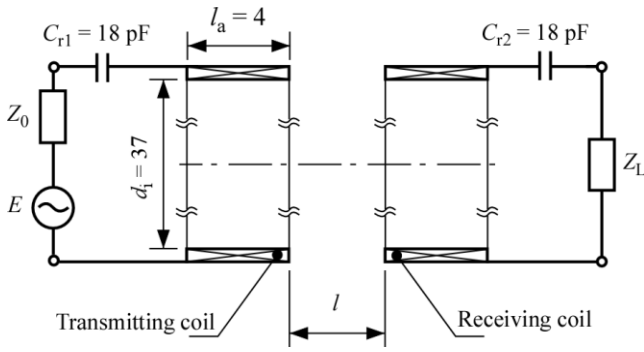

Fig. 3. Wireless power transfer of magnetic resonant coupling (unit: mm).

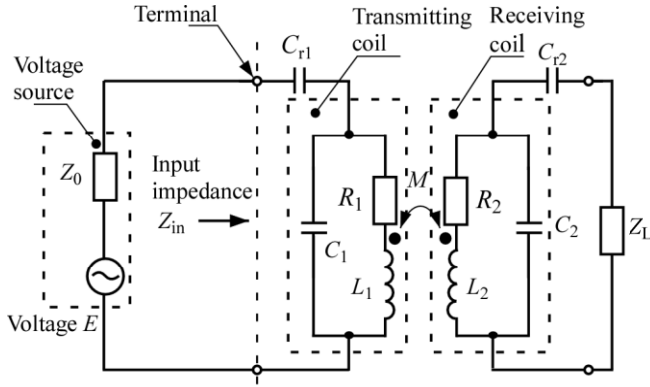

Fig. 4. Equivalent circuit of magnetic resonant coupling.

coupling. The inner diameter of the transmitting and receiving coils is $d_i = 37$ mm and their number of turns is $n = 10$, and the capacitors $C_{r1} = C_{r2} = 18$ pF are connected in series. The coils are air core coils wound closely, and the axial direction length of the LCW and LMW coils is $l_a = 4$ mm. The transmission efficiency is measured at the transmission distance $l = 10$ mm and 18.5 mm.

III. BASIC CHARACTERISTICS OF COIL

Fig. 4 shows the equivalent circuit of magnetic field resonant coupling. The transmitting coil is represented by the resistance R_1 , primary inductance L_1 , and stray capacitance C_1 . The receiving coil is represented by the resistance R_2 , secondary inductance L_2 , and stray capacitance C_2 . These coils are coupled at the mutual inductance M . The capacitors C_{r1} and C_{r2} are respectively connected to the transmitting and receiving coils in series. Z_0 represents the output impedance of power supply, and Z_L load impedance. The transmission efficiency η_{21} from the transmitting side to the receiving side is shown by the following equation with the transmission coefficient S_{21} from the transmitting side to the receiving side [7]:

$$\eta_{21} = |S_{21}|^2 \times 100 = \left| \frac{2}{\alpha_1 + j\beta_1} \right|^2 \times 100 \quad (\%) \quad (1)$$

$$\alpha_1 = \frac{1}{\omega^2 k \sqrt{L_1 L_2 C_{r1} C_{r2} Q_1 Q_2 Z_0}} \left[Z_0 \left[\omega^2 \left[Q_1 Q_2 \left[L_1 C_{r2} (C_{r1} + C_1) \right. \right. \right. \right. \right. \\ \left. \left. \left. \left. + L_1 C_{r1} C_1 + L_2 C_{r1} (C_{r2} + C_2) + L_2 C_{r2} C_2 \right] \right. \right. \right. \\ \left. \left. \left. + \omega^2 L_1 L_2 \left\{ 1 - Q_1 Q_2 (1 - k^2) \right\} \left\{ C_{r2} C_2 (C_{r1} + C_1) \right. \right. \right. \right. \\ \left. \left. \left. + C_{r1} C_1 (C_{r2} + C_2) \right\} \right] - Q_1 Q_2 (C_{r1} + C_{r2}) \right] - \omega L_2 Q_1 (C_{r2} + C_2) \\ - \omega L_1 Q_2 (C_{r1} + C_1) + \omega^3 L_1 L_2 (C_{r1} + C_1) (C_{r2} + C_2) (Q_1 + Q_2) \\ + \omega^3 C_{r1} C_{r2} Z_0 Z_L \left\{ L_1 C_1 Q_{21} + L_2 C_2 Q_1 \right. \\ \left. - \omega^2 L_1 L_2 C_1 C_2 (Q_1 + Q_2) \right\} \right] \quad (2)$$

$$\beta_1 = \frac{1}{\omega^3 k \sqrt{L_1 L_2 C_{r1} C_{r2} Q_1 Q_2 Z_0}} \left[-\omega^3 Z_0 \left[\left\{ L_1 Q_2 \right. \right. \right. \\ \left. \left. \left. - \omega^2 L_1 L_2 C_2 (Q_1 + Q_2) \right\} (C_{r1} + C_1) C_{r2} + L_1 C_1 C_{r1} Q_2 \right. \right. \\ \left. \left. \left. + \left\{ L_2 Q_1 - \omega^2 L_1 L_2 C_1 (Q_1 + Q_2) \right\} (C_{r2} + C_2) C_{r1} + L_2 C_2 C_{r2} Q_1 \right] \right. \\ \left. \left. \left. + Q_1 Q_2 - \omega^2 L_2 Q_1 Q_2 (C_{r2} + C_2) \right. \right. \right. \\ \left. \left. \left. - \omega^2 (C_{r1} + C_1) \left[L_1 Q_1 Q_2 + \omega^2 L_1 L_2 (C_{r2} + C_2) \left\{ 1 - Q_1 Q_2 (1 - k^2) \right\} \right] \right. \right. \\ \left. \left. \left. + \omega^2 C_{r1} C_{r2} Z_0 Z_L \left[\left[\omega^2 L_1 C_1 Q_1 Q_2 + L_2 C_2 Q_1 Q_2 \right. \right. \right. \right. \right. \\ \left. \left. \left. \left. + \omega^2 L_1 L_2 C_1 C_2 \left\{ 1 - Q_1 Q_2 (1 - k^2) \right\} \right] - Q_1 Q_2 \right] \right] \right] \quad (3)$$

where α_1 and β_1 are the coefficients of the real and imaginary parts of S_{21} , ω is the angular frequency (rad/s), k is the coupling coefficient, L_1 and L_2 are the primary and secondary inductances (H), C_{r1} and C_{r2} are the capacitances (F) of the transmitting and receiving sides, Q_1 and Q_2 are the quality factors of the transmitting and receiving coils, Z_0 is the output impedance (Ω) of power supply, Z_L is the load impedance (Ω), and C_1 and C_2 are the stray capacitances (F) of the transmitting and receiving coils, respectively.

Equations (1), (2), and (3) show that the coupling coefficient and the resistance of the coils must increase to improve the efficiency η_{21} [7]. The coupling coefficient depends on transmission distance; thus, it decreases with increasing transmission distance. Then, the decrease in the resistance or the increase in quality factor is examined for the improvement in efficiency η_{21} .

Fig. 5 shows the impedance versus frequency characteristics of the coils. The impedance characteristics were measured with an impedance analyzer (Agilent, 4294A). The resistances of the LCW and LMW coils at the frequency $f = 12$ MHz were 6.8 Ω and 4.1 Ω , respectively; thus, the resistance of the LMW decreases by 40% compared with that of the LCW. The inductances of the LCW and LMW coils at the frequency $f = 12$ MHz were 7.47 and 7.57 μH , respectively; thus, the inductance of the LMW increases by 1.3% compared with that of the LCW. Therefore, the quality factors of the LCW and LMW coils at the frequency $f = 12$ MHz were 83 and 138, respectively; thus, the quality factor of the LMW increases by 66% compared with that of the LCW.

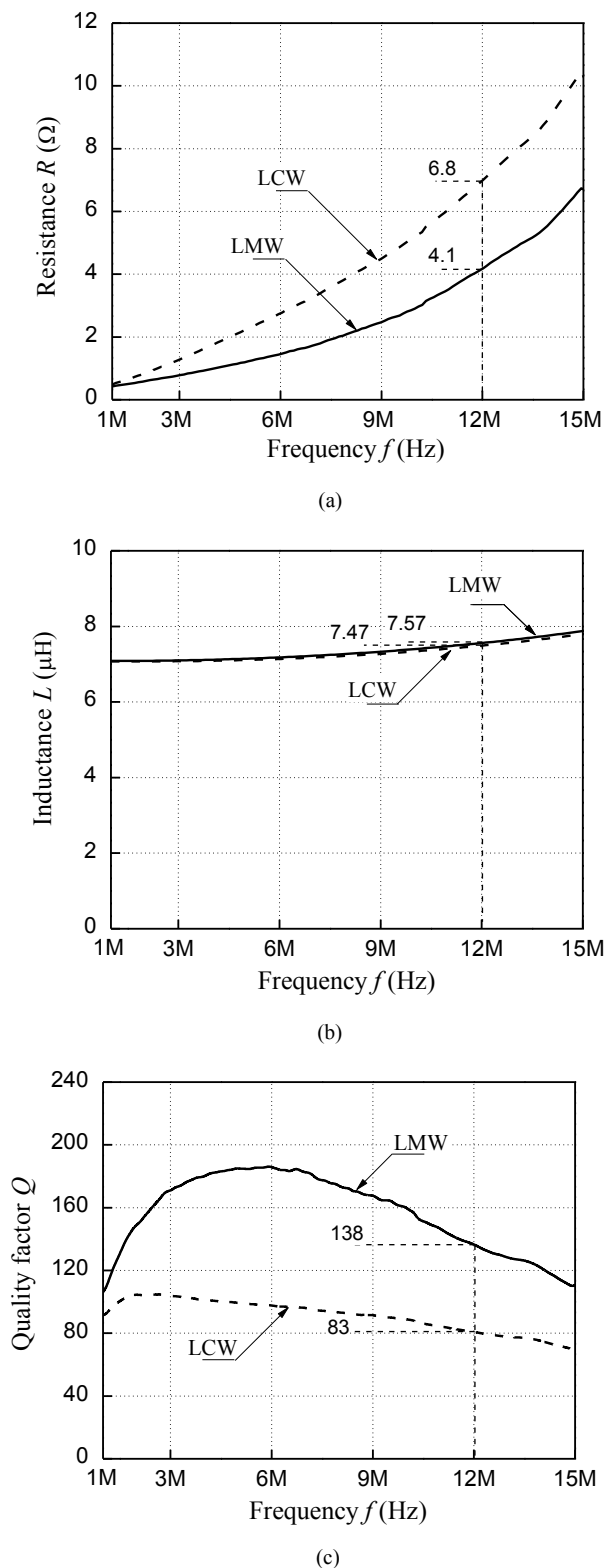

Fig. 5. Impedance characteristics of coils (measured with 4294A). (a) Resistance. (b) Inductance. (c) Quality factor.

Fig. 6 shows the coupling factor versus transmission distance characteristics. The coupling factors of the LCW and LMW coils at the transmission distance $l = 18.5$ mm were 0.093 and 0.091, respectively; thus, the coupling coefficient of the LMW

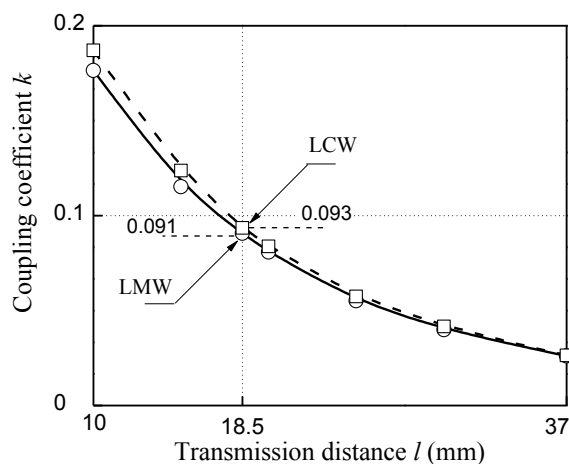

Fig. 6. Coupling coefficient characteristics (measured with 4294A).

decreases by 2.2% compared with that of the LCW. This is because the magnetic energy is stored in a magnetic thin film.

IV. TRANSMISSION EFFICIENCY CHARACTERISTICS

1) Efficiency characteristics

Fig. 7 shows the transmission efficiency versus frequency characteristics of the LCW and LMW coils. The series resonance frequency of the LCW and LMW coils is approximately 13 MHz. The efficiency characteristics were measured with a network analyzer (Agilent, E5061B). The network analyzer is measured at $Z_L = Z_0 = 50 \Omega$. The input power is $P_i = 0$ dBm in this measurement. Figs. 7 (a) and (b) show the transmission efficiency versus frequency characteristics of the coils at the transmission distances $l = 10$ mm and 18.5 mm, respectively. In Fig. 7, η_{11} is the reflection efficiency, and η_{21} is the transmission efficiency. The maximum efficiencies η_{21} of the LCW and LMW coils at the transmission distance $l = 10$ mm were 69.8% and 77.7%, respectively, indicating a 7.9% improvement in the efficiency of LMW coil. The efficiency η_{21} also improves by 8.5% at the transmission distance $l = 18.5$ mm.

2) Input impedance characteristics

Fig. 8 shows the input impedance frequency characteristics of the coil connected to the capacitor $C_{r1} = C_{r2} = 18$ pF in series. The receiving side is connected to the load impedance $Z_L = 50 \Omega$. Figs. 8 (a) and (b) show the input impedance versus frequency characteristics of the transmission distances $l = 10$ mm and 18.5 mm, respectively. The input impedance of the LCW and LMW coils at $l = 10$ mm, $f = 12$ MHz was both $Z_{in} = 56 \Omega$ as shown in Fig. 8 (a). Therefore, the input impedance Z_{in} is near the load impedance $Z_L = 50 \Omega$, and η_{11} is 5% or less, and η_{21} reaches the maximum value as shown in Fig. (7) (a). There is no reflection, and η_{21} greatly depends on the ohmic loss of the coils. The improvement in the efficiency η_{21} of the LMW coil originates from the increase in quality factor due to the reduction in AC resistance. It is similar to the above-mentioned for $l = 18.5$ mm as shown in Figs. 7 (b) and 8 (b).

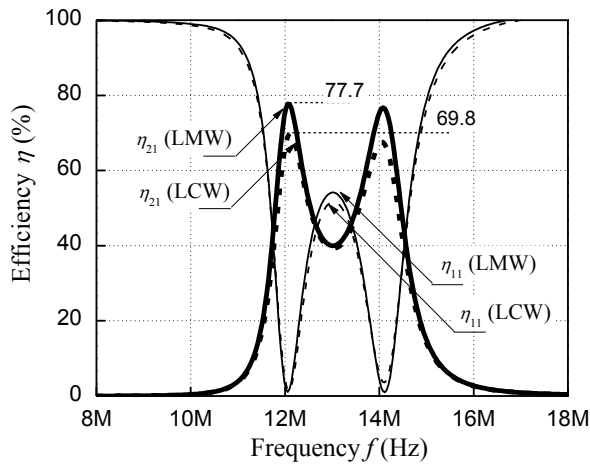

(a)

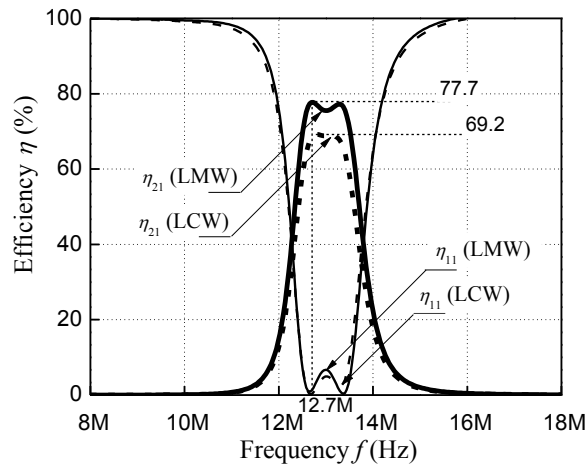

(b)

Fig. 7. Efficiency vs. frequency characteristics (measured with Agilent E5061B, $d_i = 37$ mm, $n = 10$, $C_{r1} = C_{r2} = 18$ pF, $P_i = 0$ dBm, $Z_L = 50$ Ω). (a) $l = 10$ mm. (b) $l = 18.5$ mm.

V. CONCLUSION

1) Impedance characteristics of coil

The resistances of the LCW and LMW coils at the frequency of 12 MHz were 6.8 Ω and 4.1 Ω , respectively, thus, the resistance of the LMW decrease by 40% compared with that of the LCW. The quality factors of the LCW and LMW coils at the frequency of 12 MHz were 83 and 138, respectively; thus, the quality factor of the LMW increased by 66% compared with that of the LCW.

2) Transmission efficiency characteristics

The maximum efficiencies of the LCW and LMW coils at the transmission distance $l = 10$ mm were 69.8% and 77.7%, respectively; thus, the efficiency of the LMW coil was improved by 7.9%. The maximum efficiencies of the LCW and LMW coils at a transmission distance $l = 18.5$ mm were 69.2% and 77.7%, respectively, the efficiency of the LMW coil improved by 8.5%.

The above-mentioned characteristics originating from the AC resistance due to the proximity effect of the LMW decreased and the quality factor of the LMW improved.

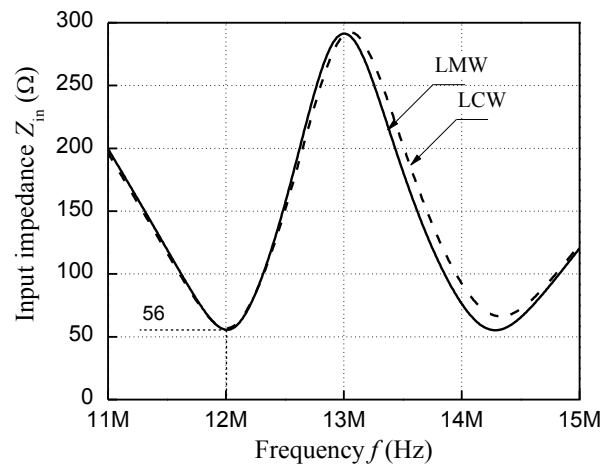

(a)

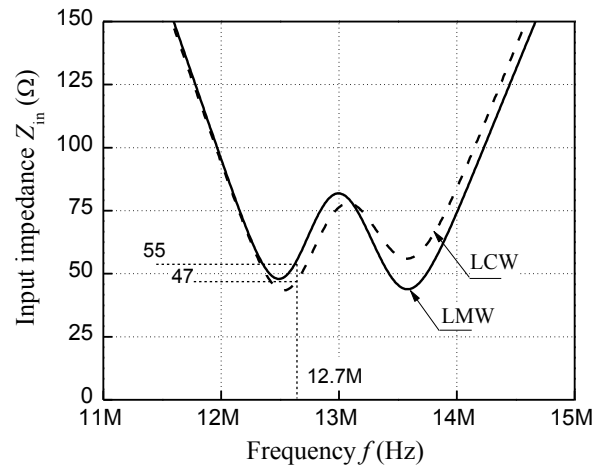

(b)

Fig. 8. Input impedance vs. frequency characteristics ($d_i = 37$ mm, $n = 10$, $C_{r1} = C_{r2} = 18$ pF, $Z_L = 50$ Ω). (a) $l = 10$ mm. (b) $l = 18.5$ mm.

REFERENCES

- [1] Y. Matsuda, H. Sakamoto, "Non-contact magnetic coupled power and data transferring system for an electric vehicle," J. Magn. Mater., Vol. 310, No. 2, Part 3, pp. 2853-2855, 2007.
- [2] A. Karalis, *et al.*, "Efficient wireless non-radiative mid-range energy transfer," Ann. Phys. Vol. 323, pp. 34-48, 2008.
- [3] A. Jesus, A. Rafael, B. Jose M., B. Luis A., P. Diego, "Frequency-dependent resistance in litz-wire planar windings for domestic induction heating appliances," IEEE Trans. Power Electron., Vol. 21, No. 4, pp. 856-866, 2006.
- [4] T. Mizuno, S. Enoki, T. Hayashi, H. Shinagawa, "Extending the linearity range of eddy-current displacement sensor with magnetoplated wire," IEEE Trans. Magn., Vol. 43, No. 2, pp. 543-548, 2007.
- [5] S. Yoshimura, S. Yoshihara, T. Shirakashi, E. Sato, K. Ishii, "Characteristics of high-Q coils composed of Fe-plated Cu wire," Magneto-Electronics International Symposium, pp. 485-487, 1994.
- [6] T. Mizuno, S. Enoki, T. Asahina, T. Suzuki, M. Noda, H. Shinagawa, "Reduction of proximity effect in coil using magnetoplated wire," IEEE Trans. Magn., Vol. 43, No. 6, pp. 2654-2656, 2007.
- [7] T. Imura, H. Okabe, T. Uchida, Y. Hori, "Study on open and short end Helical antennas with capacitor in series of wireless power transfer using magnetic resonant couplings" Annu Conf IEEE Ind Electron Soc., Vol. 35th Vol. 6 pp. 3654-3659, 2009.