



A reconstruction of the Greek–Roman repeating catapult

Cesare Rossi*, Flavio Russo

Department of Mechanical Engineering for Energetics (DIME), University of Naples "Federico II", Via Claudio, 21, 80125 Naples, Italy

ARTICLE INFO

Article history:

Received 21 February 2009

Received in revised form 17 July 2009

Accepted 29 July 2009

Available online 4 September 2009

Keywords:

History of Engineering

Ancient automatic weapons

Mechanism reconstruction

ABSTRACT

An "automatic" repeating weapon used by the Roman army is presented. Firstly a short description is shown of the working principle of the torsion motor that powered the Greek–Roman catapults. This is followed by the description of the reconstructions of these ancient weapons made by those scientists who studied repeating catapults. The authors then propose their own reconstruction. The latter differs from the previous ones because it proposes a different working cycle that is almost automatic and much safer for the operators. The authors based their reconstruction of the weapon starting from the work of previous scientists and on their own translation of the original text (in ancient Greek) by Philon of Byzantium.

© 2009 Elsevier Ltd. All rights reserved.

1. Introduction

Among the designers of automata and automatic devices in ancient times Heron of Alexandria (≈ 10 B.C.–70 A.D.) was probably the best known. In some of his treatises (e.g.: *Pneumatica*, *Automata*) Heron described statues having human semblances (automaton) that were moved in a theatre acting as actors, animals that drank, singing birds and other devices, all moved by steam or water. Heron was one of the many scientists belonging to the Hellenistic school and, the influence of the Hellenistic thinking and knowledge on science and philosophy was very strong for some centuries after the I century B.C. Hence the existence of automatic devices in the Greek–Roman age is well-known.

Nevertheless the presence of automatic weapons in the Greek–Roman era is not very widely known.

Certainly the Roman Empire was conquered and held not only by the army itself but also by Roman technology and modernity. This modernity was not only in the field of the Law and Literature but also (and perhaps mostly) in the field of Engineering and Science. Engineering, in particular, was more advanced than one can commonly think; this certainly in the field of architectural works but probably even more in the field of Hydraulics and Mechanics. Although the knowledge of Mechanics was surprisingly advanced, this field is probably less known than others since archaeological finds are less evident, smaller and sometimes unrecognised. Among the devices developed 2000 years ago in the field of mechanics, the ones interesting are those used for military purposes and, in particular, the repeating catapult.

Catapults and ballistae represented the light artillery pieces of the Roman Army; after the fall of the Roman Empire these weapons were widely used by several armies up to the XV century, until black powder became commonly used. The word catapult comes from the Greek (κατα = through and πελτη = shield). The first catapults were developed by the Greeks of Syracuse (eastern Sicily, Italy). The researches on these machines, that were financed by Dionysius the Elder (430–367 B.C.), required mathematical and technical skills in order to design such machines and to maintain and operate them [1,2]. During the Roman Empire the word "catapulta" was used for a machine that throws darts, while the word ballista (that

* Corresponding author. Tel.: +39 081 7693269; fax: +39 081 2394165.

E-mail addresses: cesare.rossi@unina.it, rossi_cesare@fastwebnet.it (C. Rossi).

also comes from the Greek word βαλλω = to throw) was used for a machine that throws balls. During the Middle Age the words were used with the opposite meaning: ballista for a dart throwing machine and catapult for a ball throwing one.

Almost all these weapons were not repeating devices since they had to be reloaded after each strike was thrown, but one little catapult (a scorpion) was a repeating weapon. It was very probably designed by Dionysius of Alexandria, and represents the first example of a repeating weapon.

The weapon was studied by several authors (see, e.g. [3–6]) who assume that the mechanism was operated by turning a windlass in a direction for the first half of the cycle and in the opposite direction for the second half of the cycle.

The authors of the reconstruction here presented, think that such a working principle had some disadvantages and, after a brief review on the motors used for catapult and ballistae, propose their reconstruction in which the mechanism is moved by a windlass that is rotated always in the same direction.



Fig. 1. Author's virtual reconstruction of a Roman catapult with torsion motor.

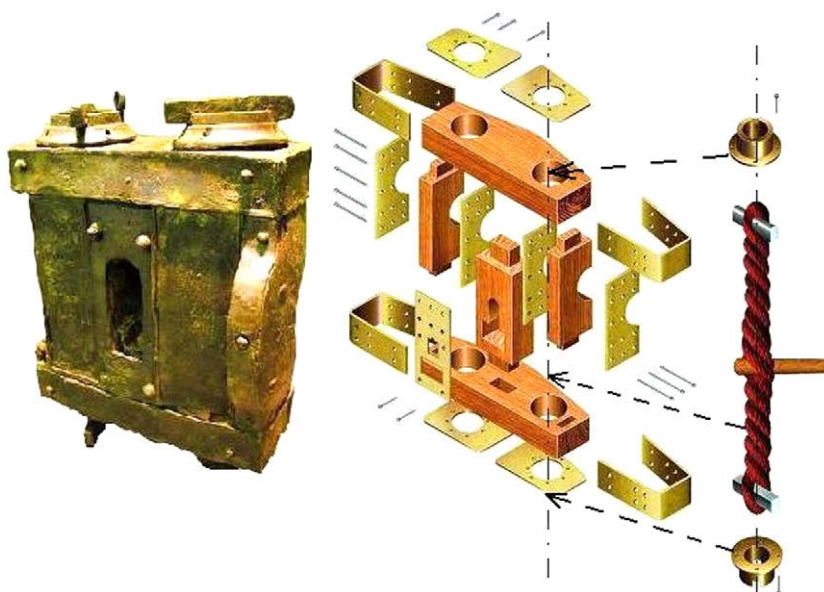

Fig. 2. Propulsor of a Roman catapult: finds (left) and author's reconstruction (right).

2. Ancient torsion motors

Other authors have studied these ancient weapons operated by torsion motors in detail (see, e.g. [1–8]) so we will confine ourselves to a brief description of the torsion motor for ancient weapons.

From a general point of view, the ideal motor for a launching machine would have had to be small and powerful: according to sources something of the sort appeared around the middle of the IV century B.C. It may have been suggested by the torsion press, used in Egypt for thousands of years to press vegetable essences, or the more recent frame-saw with a rope and rod tightener. Difficult to determine now: what we do know is that this was the period in which the first torsion artillery appeared on the scene but in just a few decades it replaced flexion artillery. The development in the design of torsion motors for projectile throwing machines is very interesting; although it is not the main aim of the present paper, it can be interesting to briefly remember some aspects highlighted by other authors in their researches (see, e.g. [1,8]).

From a construction aspect, a torsion motor consisted of a strong wooden square frame, reinforced by iron straps, divided into three separate sections. The central section was used to insert the shaft of the weapons, while the sides were for the two coils of twisted rope. As far as these coils or bundles is concerned, it must be said that one of the main steps was represented by the establishment of the optimum ratio between the diameter and the length of the coil [1,2,7]. Inside the coils arms were fitted to which the rope was affixed, like the ends of an archery bow. The last major improvement in the catapult design was achieved during the Roman Empire when the most stressed components of these machines were made by metal (iron and

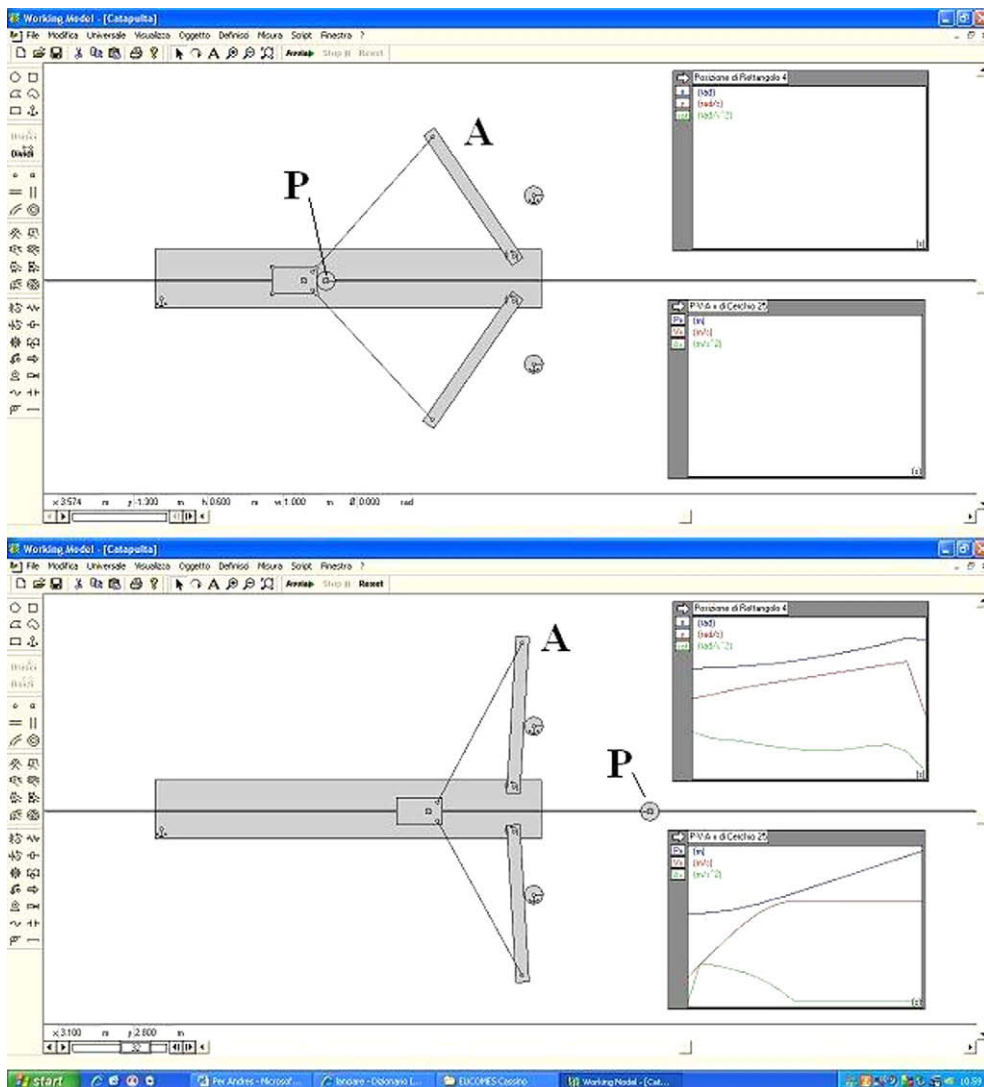

Fig. 3. Multibody model of a torsion motor weapon.

bronze) allowing reduction in size, increase of the permissible stress levels and greater freedom of travel for the bow arms [2].

In Fig. 1 is reported a virtual reconstruction of a Roman catapult with torsion motor, according to data provided by Vitruvius.

Fig. 2 shows a propulsor of a Roman catapult found in Xantem, Germany and an exploded view of it with one of its coils. Contrary to traditional ropes, the coils were not made of twisted vegetable fibres but of bovine sinews, horsehair or women's hair. Keratinous formations were preferred for their superior resistance, excellent for elastic motors that worked by repeated cycles of torsion and immediate return. Since the kinetic power of a weapon depended on the diameter of the coils, the diameter became the dimensional module, just like the caliber in modern artillery.

The only and not insignificant drawback of torsion motors was the strongly hygroscopic nature of the coils, which were weakened when they came into contact with water or a humid environment. Rain or even a prolonged exposure to humidity or fog drastically decreased its potential. This problem was solved by Ctesibius who invented a pneumatic ballista (see, e.g. [8,9]) that was described by Philon of Byzantium.

The dynamics of catapults and ballistae powered by torsion motor can be easily studied by simulation codes. For example, Fig. 3 shows a multi-body model of a ballista with a torsion motor made by the code WM2D, at the beginning (top) and at the end (bottom) of the working cycle.

In Fig. 4 there are reported some examples of the diagrams shown on the right side of the WM2D frame enlarged. These diagrams show position (1), speed (2) and acceleration (3) of the arm A (left) and the projectile P (right) and are reported as a function of time for two projectiles with a different mass: a relatively light mass projectile in the top diagrams and for a higher mass projectile in the lower diagrams; both the projectiles were thrown by the same machine. In the diagrams no sizes are reported since the values (expressed in rad, rad s^{-1} and rad s^{-2} or in m, m s^{-1} and m s^{-2}) are automatically scaled by WM2 in order to represent the curves that refer to a same body in the same diagram. Naturally all these values depend on a number of factors such as: torsion stiffness of the springs, arm length, mass of the projectile, frictions and dampings, each of which can be easily modified in the model. By means of the same model, forces and torques can be also computed very easily. In this way, by means of a rather simple 2D model, the influence of several factors can be considered on the behaviour of such a machine. In fact if the diagrams in the first row (light weight projectile) are compared to those in the lower row (high weight projectile) the differences in the dynamic behaviour are clearly visible.

The example above shows that there is an optimum ratio between the projectile mass and the energy of the torsion motor coil in order to achieve the optimum performance of a given machine. This was clearly understood by the ancient catapult designers.

As already illustrated, the optimum ratio between the diameter and the length of the coil was established [1,2,7]; hence the coil diameter alone was sufficient to give the data about the stiffness of the motor's springs and, hence, of the energy that the machine could develop. The latter greatly depends on the coil volume, this can explain the efforts, made since ancient times, to compute the square root. The problem was solved by a number of ancient Greek scientists and probably the most well-known are the ones by Hippocrates of Chios ($\approx 470\text{--}410$ B.C.) and by Eratosthenes (276–195 B.C.); they both conceived and built devices, called mesolabio, that could compute the cubic root (see, e.g. [10]). According to Chondros [1] the optimization of the coils of twisted fibres (or cord bundle) was completed around 270 B.C. perhaps by a group of Greek engineers working in Egypt, Thera (the ancient Santorini) and Rhodes and most of the group of the solvers of the cube-root problem had either a direct or an indirect connection with catapults; Eratosthenes stated explicitly that the catapult was the main practical reason why he worked on cubic roots.

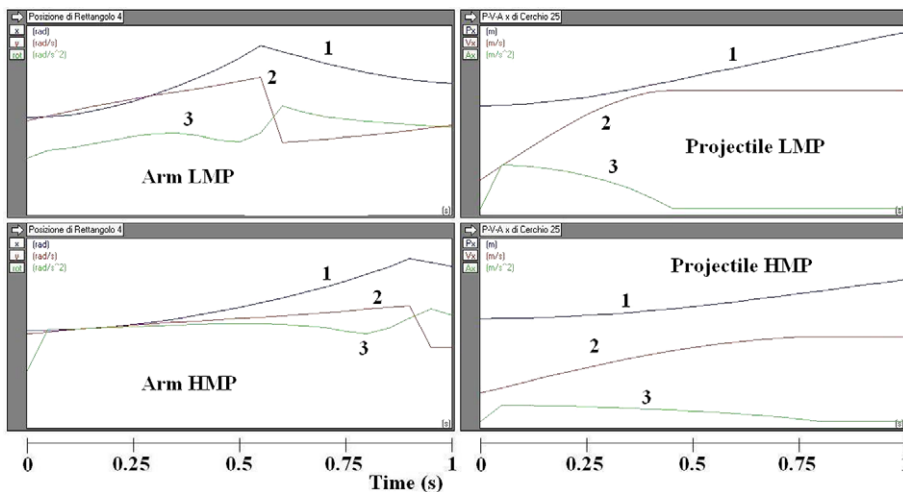

Fig. 4. Position (1), speed (2) and acceleration (3) of the arm A and the projectile P for a light mass projectile (LMP) and for an high mass projectile (HMP).

From a general point of view, in machine design problems, usually the number of unknown parameters is order of magnitude greater than the available data of specifications. This uncertainty can be eliminated to a small extent by optimization methods and by the designer's judgment. This was true 20 centuries ago like nowadays.

3. The repeating catapult

The authors have based their reconstruction of the weapon starting from the work of previous scientists [1–4] and on their own translation of the original text (in ancient Greek) by Philon of Byzantium.

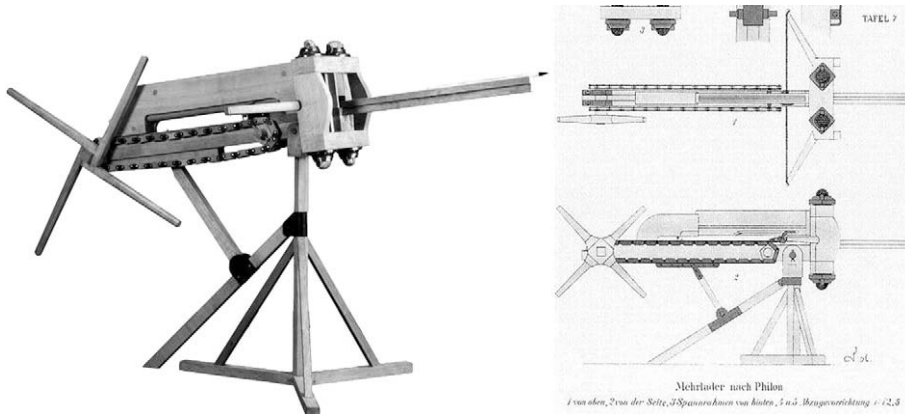

Fig. 5. Repeating catapult: reconstruction at the Museum für Antike Schifffahrt in Mainz (left) and the design by Schramm [1], Tafel 7 (right).

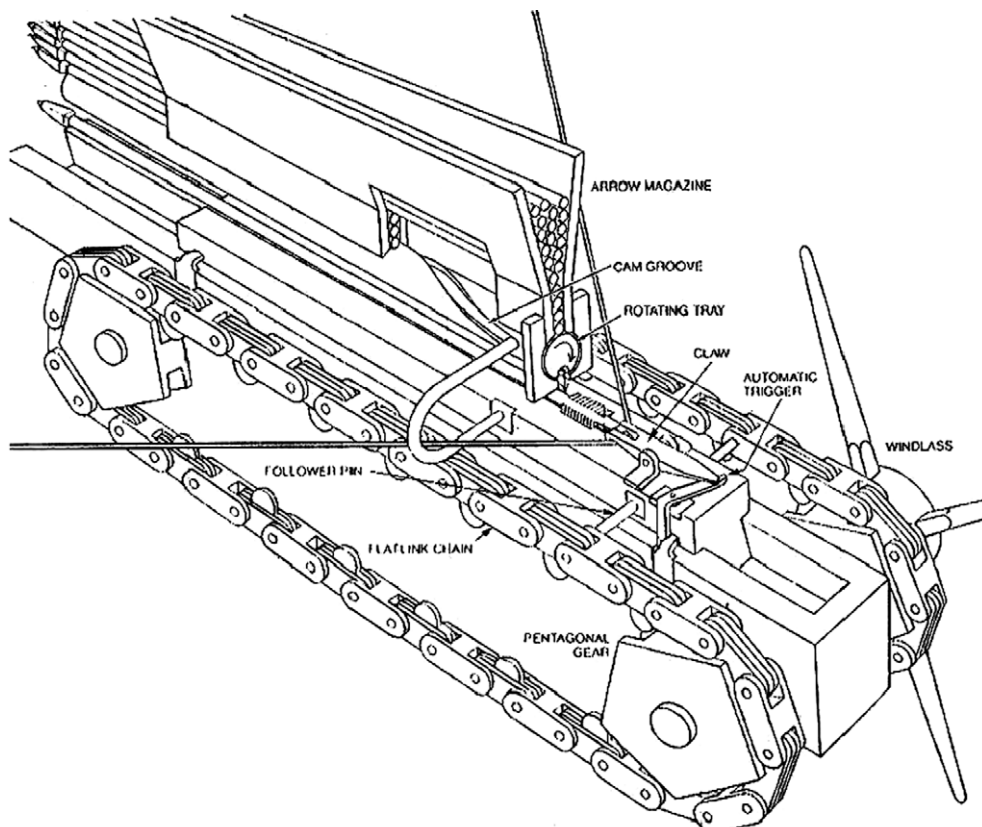

Fig. 6. Reconstruction by Soedel and Foley [6].

The device is described by Philon of Byzantium and can be considered as a futuristic automatic weapon that throws 481 mm long darts. This machine was attributed to Dionysius of Alexandria and, apparently, it was used around the I century B.C.; it was a part of the arsenal of Rhodes that may be considered as a concentration of the most advanced mechanical kinematic and automatic systems of the time, many of which show working principles and a conceptions that still can be considered as “modern” [10]. Reconstruction of very ancient devices is often difficult. The one of the repeating catapult, for instance, is based on old texts (e.g. [11]), on the work carried out by Schramm [3] that is also reported by Marsden [4,5] with the original description by Philon of Byzantium. As for this last description it has to be pointed out that ancient Greek has no technical terms: for instance in “Ta Filonos Belopoika 75, 33–34” the chainmail is called “πλινοθιζα” = little brick and the teeth of the chain mails are called “περοναιζα” = fin. Hence, the description left to us by Philon, as is easily understandable, was not written to eliminate all doubt, since it lacks a technical glossary and an analytic style.

3.1. Previous reconstructions

Although the repeating catapult has already been described “in modern times” by Baldi [11], the first studies on it were carried out by a German officer, Schramm [3], who built a model of it at the beginning of the XX century. It must be said that a reconstruction based on Schramm’s studies is still held at the Museum für Antike Schifffahrt (Museum of Ancient Shipping) in Mainz (Germany) and is shown in Fig. 4 together with a design by Schramm. For his reconstruction, Schramm used a chain very similar to a bicycle chain as it can be observed in Fig. 5.

One of Schramm’s prototypes was tested at the presence of the Kaiser; during the test one arrow split in two the one that was previously thrown on the target.

Later, this device was also studied by Marsden and other authors (see, e.g. [4–6]). In Fig. 6 is reported a design by Soedel and Foley [6]; it is based on the same working cycle conceived by Schramm and Marsden.

All the reconstruction and the studies carried out till now suppose that the repeating mechanism is operated by turning levers, windlasses or cranks in a sense for the first half of the cycle and in the opposite sense in the second half of the cycle. That is to say: in a first phase of the working cycle the operators had to turn the windlass in a direction to charge the weapon, at the end of this phase the missile was thrown then the operators had to turn the windlass in the opposite direction in order

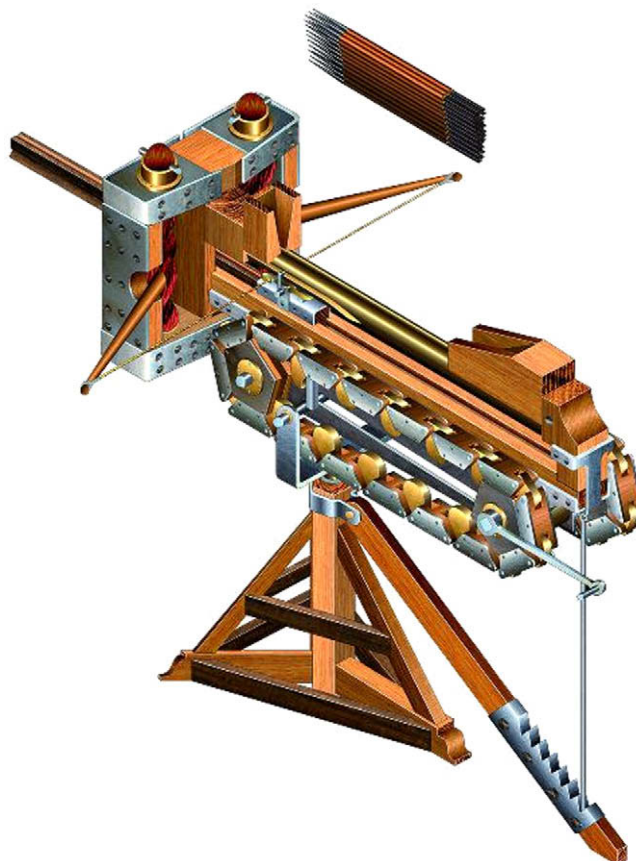

Fig. 7. Authors' pictorial reconstruction of the automatic catapult.

to carry the mechanism back to the starting configuration. In this way, among other things, once one cycle was started, it could be very difficult to stop or to pause it; this is because in the first half of the cycle the torsion motor was charged and no non-return devices could be used since the windlass should be free to rotate in both directions. The authors of

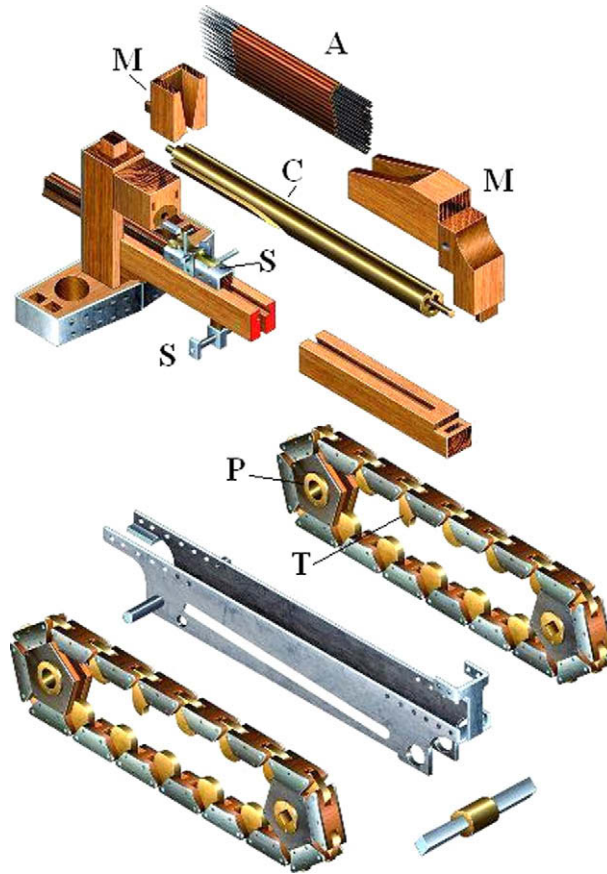

Fig. 8. Details of the mechanism.

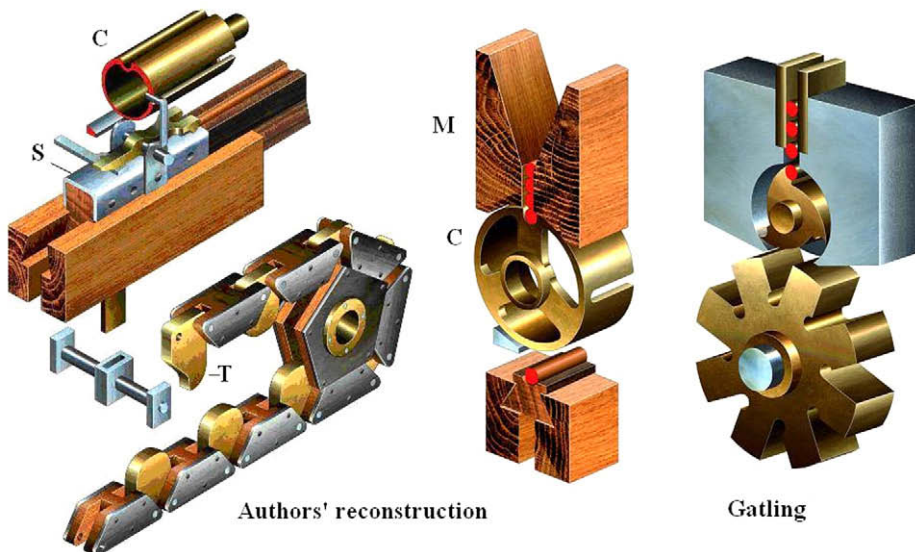

Fig. 9. Details of the mechanism (left and centre); Gatling gun mechanism (right).

the reconstruction here presented, think that such a working principle had some disadvantages: it had little efficiency, was difficult to be operated during a battle and was also dangerous for the operators.

Instead, a mechanism that was operated by turning the windlass always in the same direction of rotation and the presence of a non-return mechanism could greatly simplify all the operating sequence by the operators, increasing both the rate of fire and the working safety. In fact it would have been possible to stop the working sequence at any step of it. Finally the whole mechanism would have been automatic from a wider point of view.

For the reasons above, the authors tried to interpret the description of the mechanism described by Philon of Byzantium (that is reported by Marsden [4,5]) in order to permit that the whole cycle was operated by simply turning the levers in the same direction.

3.2. The author's reconstruction of the repeating catapult

A pictorial author's reconstruction of the repeating catapult is shown in Fig. 7. The repeating device essentially consisted in a container holding within it a number of arrows, a cylinder feeding device and movement chain.

Fig. 8 is another pictorial reconstruction by the authors showing some details of the mechanism. In this figure the particulars that permit to operate the whole cycle by rotating the windlass always in the same sense of rotation. According to Philon and to other authors' reconstructions, the arrows A were located in a vertical feeder M (see Figs. 8 and 9) and were transferred one at a time into the firing groove by means of a rotating cylinder C activated alternatively by a guided cam, in

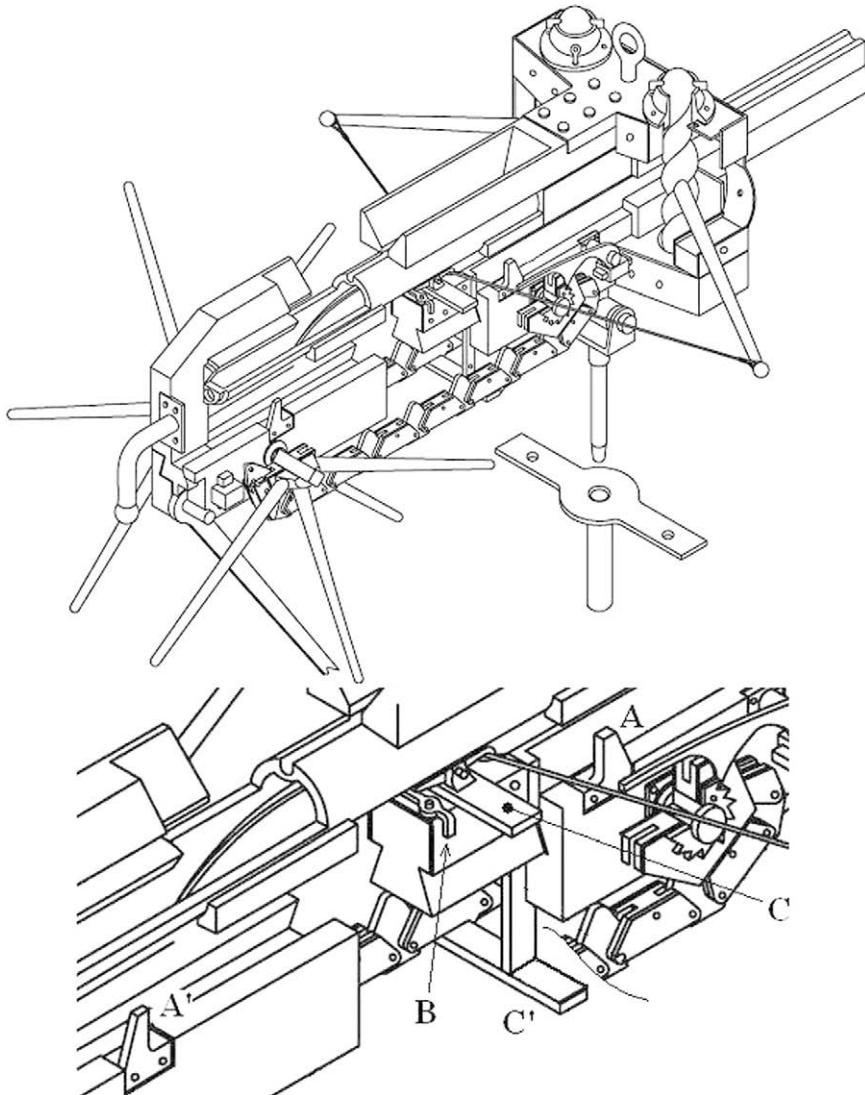

Fig. 10. Perspective section of the repeating catapult.

turn activated by a slide. The guided cam is represented by a helical groove in the rotating cylinder in which a pin connected to the slide is located. Hence, a simple rotation of the crank was sufficient to move the cylinder, the slide, the slide hooking mechanism and the trigger mechanism. The cycle repeated automatically without interruption or inverting the rotation of the sprocket until the magazine was empty, a magazine that could be reloaded without suspending firing. In the figure the slide S and the pentagonal wheels P are also represented.

It is interesting to note that the motion from the “motor” shaft to the other parts occurred by means of two flat link chains pulled by pentagonal sprockets, as shown also in Fig. 9. These, similar to modern electrical saws, had interior teeth that were inserted into the spaces of the pentagonal motor sprocket and the return sprocket, preventing them from exiting. Similar types of chains, called Galle, are attributed to Leonardo da Vinci and transmit motion in bicycles and motorcycles.

The difference between our reconstruction of this device and the previous ones mainly consists in the reload sequence: the other authors suppose that the crank handles had to reverse the rotation for each strike, while we suppose the direction of rotation was always the same. This seems to us more believable also because, in this way, the ratchet could have worked correctly and the rate of fire could have been maintained quasi constant.

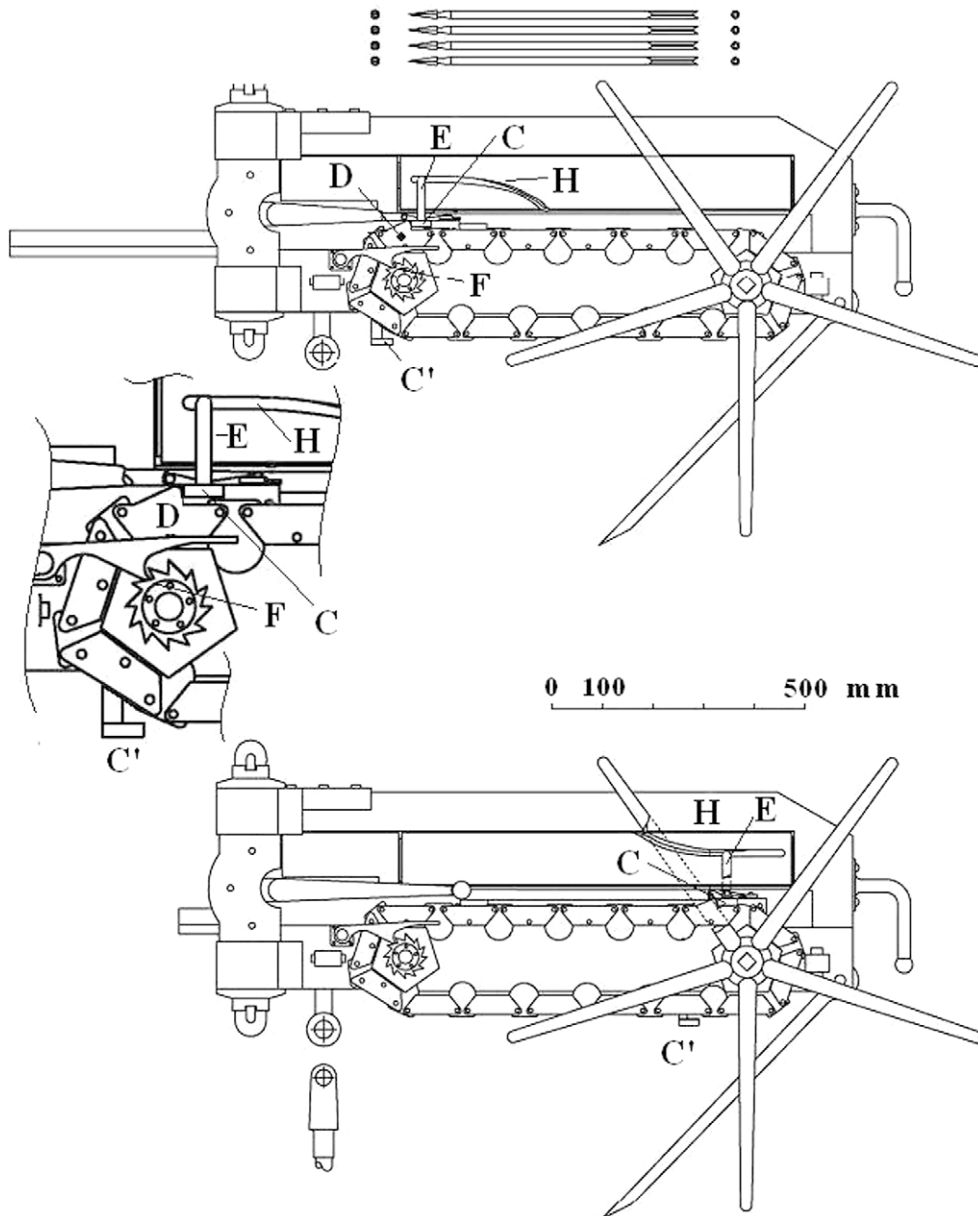

Fig. 11. Side view of the repeating catapult.

In our reconstruction of the chain and trigger mechanism shown in Fig. 9 one of the longer interior teeth T pulls the slide S which in turn pulled the cord, loading the coils of the motor. When in motion, an attached cam caused a 180° rotation in the direction of the loader cylinder C, drawing an arrow from the magazine and placing it in the channel in front of the rope. When the slide reached the rear of the weapon, the cog released it, while another opened the release mechanisms. An instant later, upon completion of sprocket rotation, the same cog coupled with the slide from underneath, pulling in the opposite direction. Near the top of the weapon, the second device closed the hook after it had retrieved the cord, while the feeder cylinder picked up another arrow from the feeder. A half rotation in the sprocket and the cycle was repeated.

Fig. 9 also shows the feed mechanism compared with the one of the Gatling machine gun; the latter is considered as the first (1862 US patent) machine gun and its working principle is still used for modern aircraft automatic weapons.

Fig. 10 shows a perspective section of another reconstruction by the authors and an interesting part enlarged. In the figure is also shown the trigger lever B that is activated when the slide reaches the end of its backwards run as soon as the trigger lever touches cog A'; during the forward run of the slide, the trigger lever is re-armed when it touches cog A. Fig. 10 also shows the two bar lines C and C' that are connected to the slide and permit the chain to hook up the slide.

In Fig. 11 is reported side view of the authors' reconstruction; from top to bottom: unloaded catapult, a detail around the front sprocket and loaded catapult. In this reconstruction the crank is substituted by levers disposed in radial direction on the hub. From the figure it is possible to observe: the two bar lines C and C' that are connected to the slide and hooked by a knob D that is one of the chain mails; the bar line and pin E that rotates the feeding cylinder by means of a helical groove H on the cylinder itself when the slide moves back and forth. The authors also supposed the presence of a ratchet mechanism F that probably was adopted to avoid a dangerous retrograde motion if the bars of the "motor" were released during the loading cycle.

The authors believe that it is more simple (and hence more believable) that the hooking up of the slide by the chain was obtained by means of the chain cog as shown in the last figure. In any case, it must be remarked that, according to the authors' reconstructions, the whole sequence was obtained by rotating the shaft always in the same direction.

From a ballistic perspective, the speed of firing must have been an average of five strokes per minute: very little when compared to modern automatic weapons, but certainly impressive for the era. Paradoxically, this would have been useless as it concentrated all the arrows in the same location in such a short period of time that it continued to strike the same target. As already told, an unquestionable demonstration of its potential was confirmed in the early 1900s, when a life size reproduction was made in Germany: during the testing performed before the Kaiser, one of its arrows split another arrow exactly in two parts.

4. Conclusion

The presented reconstruction is absolutely compatible with Philon's description and matches the reconstruction suggested by other researchers. From a mechanical point of view, the few differences only consist in some little particulars, but these differences permit a rather different working cycle. As already mentioned, the difference essentially consists in that, according with author's reconstruction, the windlass is rotated by the operators always in the same direction while in all the previous reconstructions other researchers supposed that the windlass had to reverse the rotation for each strike.

Obviously the authors of the presented reconstruction think that their one is the most reliable. Anyway, it is clear that, if the windlass rotation was always in the same direction, this would have given great advantages. First of all the presence of a non-return mechanism would have been possible (it is shown in Fig. 11) that could greatly simplify all the operating sequence by the operators, increasing both the rate of fire and the working safety. Then it would have been possible to stop the working sequence at any step of it. Finally the whole mechanism would have been automatic from a wider point of view. If the automata and automatic devices, that were invented in the same period (see, e.g. [12–14]), are considered, one can understand that the ideas and the knowledge about automatic devices in that age were rather advanced.

References

- [1] T.G. Chondros, The development of machine design as a science from classical times to modern era, in: Proceedings of the International Symposium on History of Machines and Mechanisms November 11–14, 2008, Tainan, Taiwan (HMM 2008), Springer, Netherland, 2008, ISBN 987-1-4020-9484-2 (Print) 978-1-4020-9485-9 (Online).
- [2] T.G. Chondros, in: Marco Ceccarelli (Ed.), Archimedes (287–212 BC) History of Mechanism and Machine Science 1, Distinguished Figures in Mechanism and Machine Science, Their Contributions and Legacies, Part 1. University of Cassino, Italy, Springer, The Netherlands, 2007, ISBN 978-1-4020-6365-7.
- [3] E. Shramm, Die antiken Geschütze der Saalburg, 1918, Reprint, Saalburg Museum, Bad Homburg, 1980.
- [4] E.W. Marsden, Greek and Roman Artillery Historical Development, II ed., Oxford University Press, 1969.
- [5] E.W. Marsden, Greek and Roman Artillery: Technical Treatises, Oxford, 1971. pp. 106–184.
- [6] V. Soedel, V. Foley, Ancient Catapults, Scientific American, 1979. March.
- [7] A. Iriarte, The Inswinging Theory, Gladius XXIII, 2003, pp. 111–140.
- [8] F. Russo, Tormenta Navalia L'artiglieria navale romana, USSM Italian Navy, Roma, 2007.
- [9] F. Russo, C. Rossi, F. Russo, Automatic weapons of the Roman Empire, in: Proceedings of the Eucomes, 2008.
- [10] C. Rossi, F. Russo, F. Russo, Ancient Engineers' Inventions – Precursors of the Present. Springer, Series: History of Mechanism and Machine Science, vol. 8, 2009, ISBN: 978-90-481-2252-3.
- [11] B. Baldi, Heronis Ctesibii Belopoeka, hoc est, Telifactiva, Augusta Vindelicorum, typu Davidu Frany, 1616.
- [12] F. Russo, C. Rossi, M. Ceccarelli, F. Russo, Devices for distance and time measurement at the time of Roman Empire, in: Proceedings HMM 2008 International Symposium on History of Machines and Mechanisms, Tainan, Taiwan, 2008, pp. 101–114.
- [13] D. de Solla Price, Automata and the origins of mechanism and mechanistic philosophy, Technology and Culture 5 (N.1) (1964) 9–23.
- [14] C. Rossi, Una breve rassegna sugli automi: la meccanica che ha preceduto i robot, I Convegno Nazionale di Storia dell'Ingegneria, 2006, pp. 715–727.