

X International Scientific Siberian Transport Forum

Thermocyclic fatigue and destruction of high pressure turbine blades in their critical sections

Mykola Kulyk, Mykola Koveshnikov, Yana Petruk*, Bohdan Petruk, Oleksandr Yakushenko

National Aviation University, 1 Liubomyra Huzara ave., Kyiv 03058, Ukraine

Abstract

In the article the critical sections and points at the leading edges of the airfoils of high-pressure turbines were reasonably defined for experimental studies of thermocyclic durability. Experimental studies of thermocyclic durability were performed for the samples of heatproof alloys for the cyclic change parameters in extreme temperatures and thermomechanical stresses that exert at the starting and running down of aircraft gas turbine engines and ground gas turbine power plants. The influence of protective coatings on thermocyclic durability of alloys and parts is mentioned in the article. The article describes the methods of determination the thermal stress in the blades. It is emphasized that extreme thermal stresses of compression in the edges of nozzle vanes and stretch on the pressure side of the airfoil occur on the operating mode "starting", and the cracks are revealed mainly on the mode "shutdown". In the intermediate stages of the flight cycle the do not exceed of the yield strength of the blade material and do not significantly affect there lative thermocycle durability of heatproof alloys. The destruction of the blades of high-pressure turbines in their cross sections along the airfoil shroud platform, in the zone of maximum temperature sand in the root sections explained from the position of the three- and multi component approach.

© 2022 The Authors. Published by ELSEVIER B.V.

This is an open access article under the CC BY-NC-ND license (<https://creativecommons.org/licenses/by-nc-nd/4.0>)

Peer-review under responsibility of the scientific committee of the X International Scientific Siberian Transport Forum

Keywords: thermocycle; high-pressure turbines; compression; gas turbine engines; structural materials; combustion chambers; gas turbine blades; temperature; temperatures cyclic loads; thermomechanical stresses.

1. Introduction

The creation of aircraft engines of the next generations is associated with the solution of a certain set of problems. According to it the main problems are: increasing of the service time of aviation gas turbine engines by a factor of 1.3 ... 3; creation of GTE service time counters considering information about actual technical state of the

* Corresponding author. Tel.: +38 (096) 397 63 53

E-mail address: y.petruk@ukr.net

main high-loaded parts, as well as the equations of main parts materials critical state under their multicomponent loading during testing of the materials and the parts manufactured from these materials in the laboratory; accurate reliable stable characteristics of low-cycle fatigue of the main structural materials and real parts, which consider their technological heredity; modern methods of studying the mechanisms and causes of cracks and other changes in the structure of materials in the most responsible and loaded parts, high-speed rotors, in order to predict their service time. All mentioned tasks are aimed at increasing the reliability and service time of the gas turbine engines, as well as their competitiveness.

However, the gradual and steady increase of aviation engines and stationary gas turbine units operating parameters, especially the gas temperature after combustion chamber, which already reaches 2000 K, compels designers and researchers not only to protect parts from too high temperatures, but also to seek reserves of thermocyclic durability of heatproof alloys under the load of extreme cyclic temperatures ($T_{g \max} \leftrightarrow T_{g \min}$) and thermomechanical stresses $\Delta\sigma_{tm}$. These loads, as result of thermal expansion of the alloy of turbine blades edges, act in radial direction especially at gas turbine engine starts and stops. They produce alternating deformations, which, together with static stresses, significantly exceed the heatproof alloys yield strength, both in compression and extension. It results in the accumulation of one direction plastic deformations ϵ_{pl} , fatigue and destruction of high-pressure turbine blades due to cyclic action of stress with different asymmetry.

2. Methods

The effect of stress vibration component σ_{-1} on the thermocyclic fatigue of heatproof alloys for combustion chambers was studied. For high pressure turbine stator and rotor blades this component is usually technically minimized and mechanically damped, so it is almost not considered in the research. Full-scale tests and researches are known to be very cumbersome, very costly and uninformative.

However, a linear dependence of the gas turbine blades bearing capacity depletion on the number of non-stationary modes in form "start-stop" is showed. This fact confirms the possibility of providing accelerated, almost equivalent-cyclic tests of heatproof alloys under conditions of action of extreme temperatures cyclic loads and thermomechanical stresses. The effect of thermal stresses on the samples is measured and researched using the well-known Coffin's method. But this method does not allow to stabilize the parameters of thermal stresses and deformations changing cyclically according to the Bauschinger's effect. This fact complicates and limits the research of heatproof alloys durability, especially its thermomechanical fatigue. Therefore, in this study and works (Kulik, et al., 2009a; Kulik, et al., 2009b) preference is given to the method and test bed allowing to stabilize the parameters of the cyclic temperatures and thermomechanical stresses complex action (certificate of authorship №873822 (Loziczki, et al., 1979)).

The aim and objectives of this research is to reasonably determine zones, cross sections and points in the stator and rotor blades of high-pressure turbine (HPT) for experimental researches of the characteristics of heatproof alloys thermocyclic durability on parameters of cyclic extreme temperatures action ($T_{\max} \leftrightarrow T_{\min}$) and thermomechanical stresses $\Delta\sigma_{tm}(\Delta T)$ with various asymmetry of cycles which are possible in operation of aviation engines and ground power plants.

Determination of critical zones, sections and points of HPT blades:

– In HPT nozzle blades (Figure 1) (solid and cooled), due to the known rule of directing the maximum flame temperature to the peripheral third of the blade, there are mainly alternating extreme thermal stresses along blades leading and trailing edges. Gas forces are relatively insignificant and mechanical ones are almost absent.

In modern HPT the extreme temperature of lades T_b significantly exceed 1200 K, temperature gradients ΔT in cross sections and in radial direction of blades are in range 250 ... 650 K. Extreme alternating thermal stresses absolute values $\pm \sigma_t$ exceed 450 ... 650 MPa. Frequently they exceed the yield strength of materials for current temperature. It is partially compensated, redistributed and lead to the accumulation of one direction plastic deformations, depletion of complex plasticity service time, destruction of blade material in the area of maximum temperatures T_{\max} (Figure 1).

Thermal stresses in the blades can be found analytically with Birger-Malinin relation, as well as finite element methods. The accuracy of these approaches relatively to the Coffin's method varies and depends on the density of the grid and software features. In works (Kulik, et al., 2009a; Kulik, et al., 2009b) the levels of thermomechanical

stresses were set and measured on test bed (Loziczkiy, et al., 1979) with elaborated Coffin's method by setting extreme operating temperatures for different alloys and their extreme differences $\Delta T = 650\text{ }^{\circ}\text{C}$.

Extreme thermal compress stress $-\sigma_{t\text{max}}$ in edges of nozzle blades and extension stress in their central parts takes place during the engine start (Figure 3 (Petruk)). Cracks open at $+\sigma_{t\text{max}}$ after this mode, mainly at the stage of engine stop.

In the intermediate stages of the flight cycle (for example for engine AI-20, see Figure 3, a, b, c): warm-up, test, take-off, flight and reduction of altitude thermal stresses, as seen in Figure 3, do not exceed half of the extreme values and, as a rule, do not go beyond blade material yield strength and have no significant effect on thermocyclic fatigue (see relative thermocyclic durability in (Petruk), Figure 3, b) of heatproof alloys. Therefore, in thermocyclic tests for thermocyclic durability of heatproof alloys as equivalent-cyclic ones, the action of these modes is added to thermocyclic durability strength limit of the corresponding alloys and parts from them and to the reliability limit of a gas turbine engine.

As can be seen in Photo 1 on the HPT nozzle blades critical cross sections are almost clearly defined in the area of maximum gas temperatures $T_{g\text{max}}$ and the corresponding maximum temperature of the blade material $T_{b\text{max}}$ and this area is localized to the size of 1...2 mm spot.



Fig. 1. Localization of HPT nozzle blades damages in a zone of maximum temperatures action (in 1...2 mm spots)

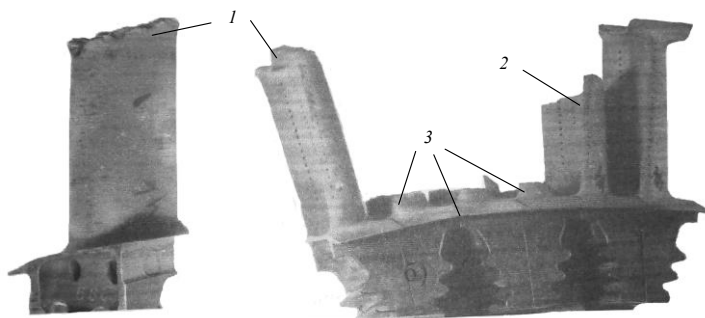

Fig. 2. Localization of HPT nozzle blades damages: 1 – in the area of bondage shelves; 2 – in the area of maximum temperatures T_{max} and thermomechanical stresses; 3 – in the area of maximum complex mechanical and thermocyclic stresses

In experimental studies of National Aviation University (Kulik, et al., 2009a; Kulik, et al., 2009b) on the thermocyclic durability of heatproof alloy samples (see Figure 4 (Kulik, et al., 2009a)) revealed a similar pattern of localization in 1...2 mm of alternating-sign deformations and destruction of samples precisely in the hysteresis zone of maximum temperature (heated and cooled $T_{\text{max}} \leftrightarrow T_{\text{min}}$), and (2...3 mm) (Kulik, et al., 2009b) but with differing asymmetries of the thermomechanical stress cycle (Kulik, et al., 2009b). Such a thermophysical analogy indicates the predominant role of maximum temperatures T_{max} , their differences ΔT and local gradients, as well as the action of extreme levels of alternating-sign thermomechanical stresses $\pm\sigma_{\Sigma\text{tm}}$ exceeding a yield strength. Such a thermophysical analogy does not contradict the concept of constructive similarity in the works (Sheremet'ev, 2012; Sheremet'ev, 2018).

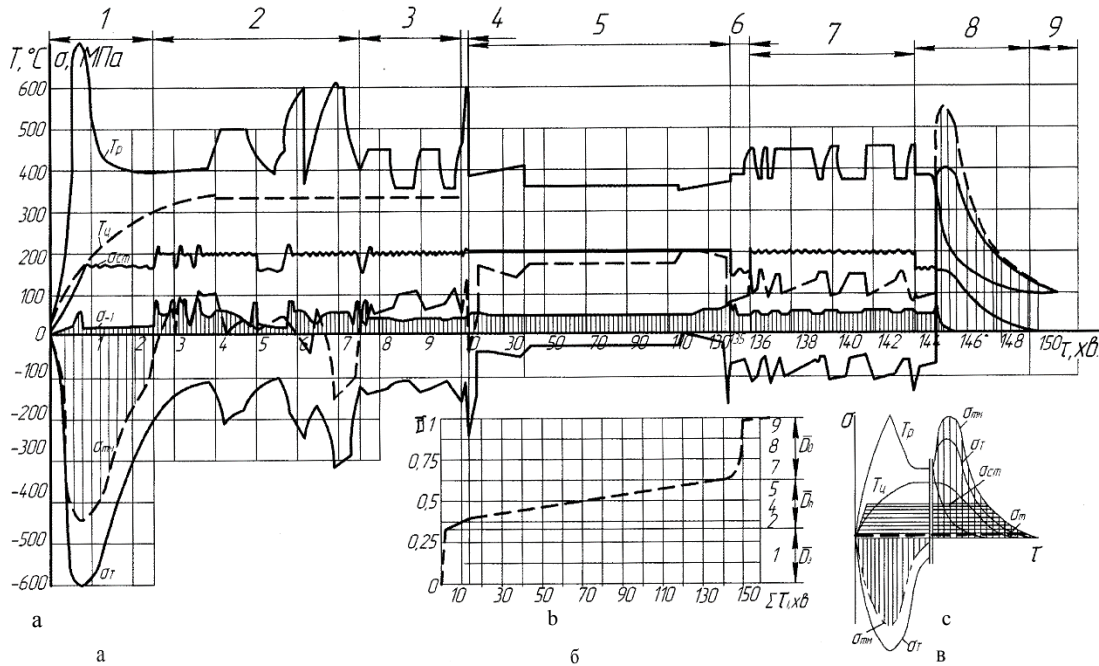

Fig. 3. Operating load of the turbine blade (a), character of damage accumulation (b) in a flight cycle (c): 1 – start; 2 – tests; 3, 7 – taxiing; 4 – takeoff; 5 – flight; 6 – landing; 8 – stop; 9 – parking

– In HPT blades (Figure 2) the spectrum of operating temperatures T and thermomechanical stresses $\sigma_{\Sigma im}$ is much more complex (Figure 5) and includes all operating components: $\sigma_{\Sigma im} = \sigma_e \pm \Delta\sigma_t + \sigma_{-1} + \sigma_{bg} + \sigma_{bc}$, where σ_e is extension stress from centrifugal forces P_c equal to the static stress on a mode $\sigma_{st} = \sigma_e$; alternating-sign thermal stresses $\pm \Delta\sigma_t$; vibrating ones $-\sigma_{-1}$; gas bending ones $-\sigma_{bg}$ bending the blade in an axial and circumferential directions as well as the bending stress of the centrifugal forces σ_{bc} .

From the standpoint of the three- and multicomponent approach (Sheremet`ev, 2018) it is possible to explain the destruction of HPT blades in these three areas (Figure 2, Figure 5): near a bandage shelf (Figure 5, 1, Figure 2, 1), in the area of maximum temperatures action (Figure 5, 2, Figure 2.2) and in the root section (Figure 5, 3, Figure 2.3).

Detailed analysis of thermal and stress state in section I (Figure 4) shows that significant temperatures of gas $T_{g \max}$ and blade alloy $T_{b \max}$ (Figure 5) appear in this zone in rather thin peripheral sections of the blade. They cause thermocyclic creepage (Pridorozhny`j, et al., 2011), which, alongside with increasing peripheral diameters of the turbine, leads to weakening of the bandage connections between blades shelves, to additional vibrations of these shelves and to destruction of section I (see Figure 2.1; 5.1 and 6, 1).

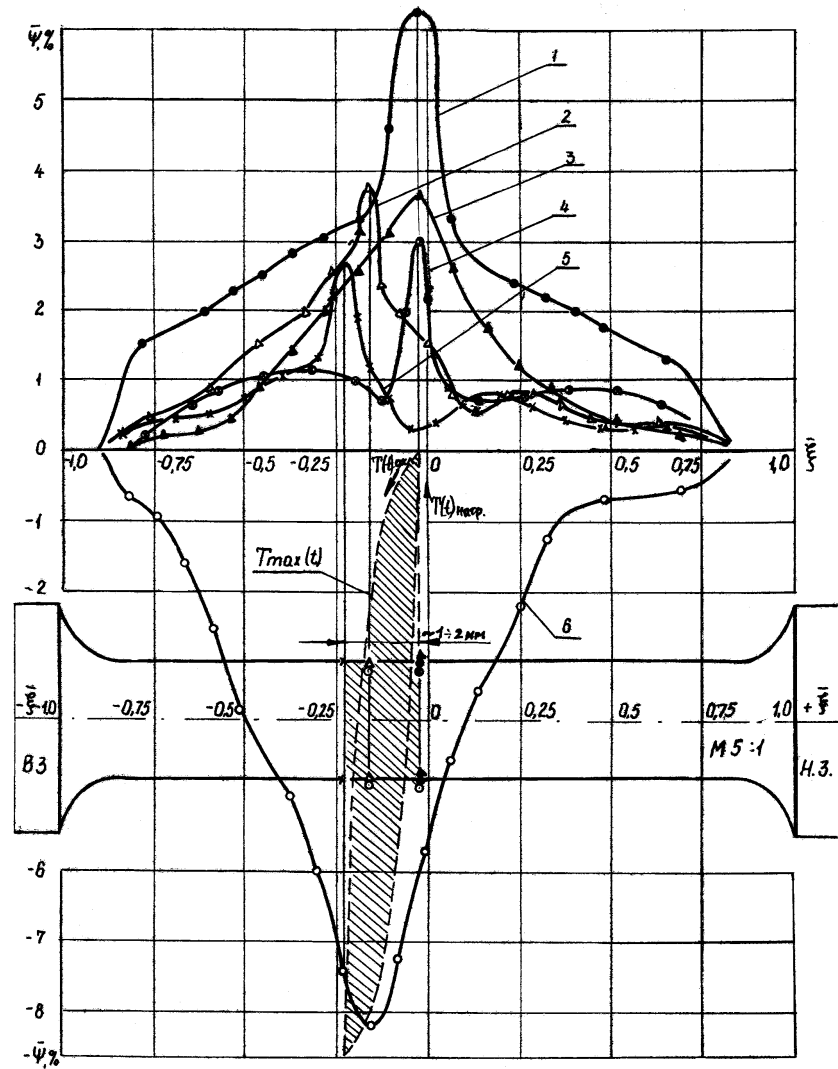

Fig. 4. Localization (0.5...2 mm) of relative transverse deformations of alloy samples before fracture under the action of thermocycles ($T_{\max} \leftrightarrow T_{\min} = 350 \leftrightarrow 1000 \text{ }^{\circ}\text{C}$) and thermomechanical stresses of different levels of asymmetry I – GS6U, $\sigma_{st} = 150 \text{ MPa}$; 2, 3 – GS6K, GS6U, $\sigma_{st} = 418 \text{ MPa}$; 4 – GS6K, $\sigma_{st} = 150 \text{ MPa}$, $\Delta\sigma_{tm} = 640 \text{ MPa}$; 5 – GS6K, $\sigma_{st} = -130 \text{ MPa}$, $\Delta\sigma_{tm} = 650 \text{ MPa}$; 6 – GS6K, $\sigma_{st} = 250 \text{ MPa}$, $\Delta\sigma_{tm} = -640 \text{ MPa}$

In section 2 (Figure. 5, 2 and 6.2), where extreme temperatures of gas $T_{g \max}$ and the blade material $T_{b \max}$ cyclically act and produce extreme thermomechanical stresses $\pm\sigma_{\Sigma tm}$, damages are obviously localized and destruction of rotor blades is observed in much the same way as in nozzle blades and samples of heatproof alloys (Kulik, et al., 2009a) (Figure 4).

In section 3 (Figure 2,3; 5,3 and 6.3) damages are localized under the cyclic action of maximum temperatures T_{\max} , mechanical ($\sigma_{st} + \sigma_{bg}$), alternating-sign thermal $\pm\sigma_t$, and vibration stresses σ_{-1} , which are summed up (especially during not mode stops of an engine), and also, after weakening of bandage links, leading to destruction in root section 3 (Figure 2 and 7).

It is not always possible to simulate the multicomponent load of rotor blades (Sheremet'ev, 2012; Sheremet'ev, 2018) in samples. In this case "Observance of a thermal similarity criteria, geometric similarity, stress and deformation equality in corresponding points of object not always possible, the simulation can be performed using the available experimentally confirmed analytical relationships between the main parameters" (Sheremet'ev, 2012; Sheremet'ev, 2018). Obviously as this "main parameters" the above-mentioned parameters of thermophysical

similarity, extreme temperatures ($T_{\max} \leftrightarrow T_{\min}$), their differences and gradients (ΔT), thermomechanical ($\Delta\sigma_{\Sigma\text{tm}}$) and static stresses σ_{st} can be used. These parameters should be such that primarily determine the thermocyclic durability of HPT alloys and parts but not their characteristics of hundred-hour and thousand-hour long-term strength which are still used to determine HPT parts and an engine in general service time.

Thus, there are prerequisites for increasing the thermocyclic durability of the most high-loaded HPT parts if it is possible to optimize the ratio of static σ_{st} and amplitude of extreme thermomechanical $\Delta\sigma_{\text{tm}}$ stresses that cyclically act during the operation of aviation gas turbine engines. The latter are determined by the formulas of the semi-ellipse (Kulik, et al., 2010):

$$\sigma_{\text{st opt}} = \sigma_{m \text{ opt}} \left(1 + \frac{1}{2 \operatorname{tg} \alpha} \right);$$

$$\sigma_m = \Delta\sigma_{\text{tm}} \operatorname{tg} \alpha;$$

$$\sigma_{m \text{ opt}} = \sqrt{(1 - \operatorname{tg}^2 \alpha) \left/ \left(\frac{a_{2\text{st}}^2 (3 - \operatorname{tg}^2 \alpha)}{(\lg N - a_{1\text{st}})^2} + \frac{a_{2\text{st}}^2 (1 - 3 \operatorname{tg}^2 \alpha)}{\operatorname{tg}^2 \alpha (\lg N - a_{1\text{r}})^2} \right) \right.},$$

where $a_{1\text{st}}$, $a_{2\text{st}}$, $a_{1\text{r}}$, $a_{2\text{r}}$ – experimental coefficients, and an angle α of the semi-ellipse of the alloys boundary characteristics. Value of α equals to 18–20° in the coordinates $\sigma_m - \Delta\sigma_{\text{tm}}$ for tests within N cycles $10^3 \dots 10^4$ (average cycle stress σ_m and difference $\Delta\sigma_{\text{tm}}$ of thermomechanical stresses).

These formulas were obtained in National Aviation University [9] using experimental data of the characteristics of thermocyclic durability of alloys such as GS6K i GS6U in complex thermomechanical load with different cycle asymmetry ($T_{\min} \leftrightarrow T_{\max} = 350 \leftrightarrow 1000$ °C). According to the results of research the mathematical model of the ultimate stresses of alloys in the form of an ellipsoid described by the equation of the fourth power on $\lg N$ (thermocyclic durability in cycles N):

$$\lg^4 N + c_3 \lg^3 N + c_2 \lg^2 N + c_1 \lg N + c_0 = 0,$$

where c_0 , c_1 , c_2 , c_3 – coefficients of the equation obtained experimentally [9].

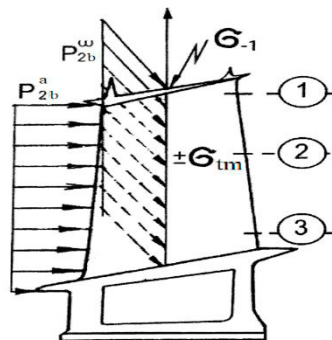

Fig. 5. Diagram of loads acting in the critical sections (1, 2, 3) of HPT rotor blade: extension stress σ_e of centrifugal forces P_c , vibrating $\sigma-1$, gas bending forces σ_{bg} in the axial P_{abg} and circumferential $P_{\omega bg}$ planes, bending stress of centrifugal forces σ_{bc} , thermal stresses $\pm\sigma_t$

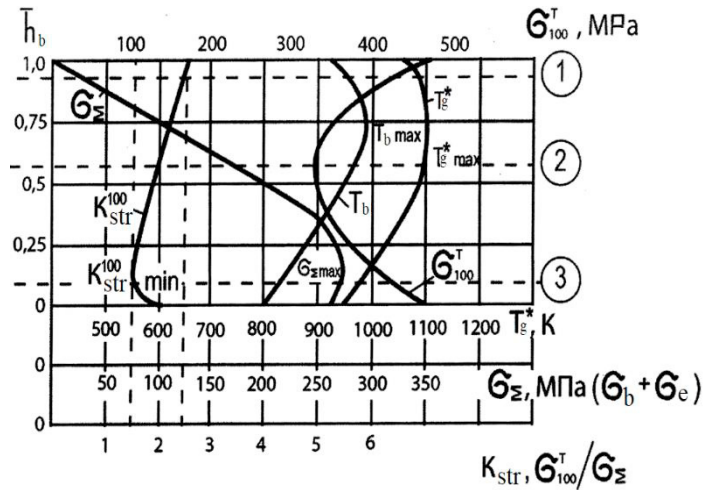

Fig. 6. The scheme of determining the safety coefficients K_{str} by the characteristics of one hundred hours of long-term strength σ_{100}^T in the critical cross sections of the HPT rotor blades without taking into account the characteristics of thermocyclic durability under conditions of cyclic temperature and thermomechanical stresses



Fig. 7. Weakening of bandage connections due to creep in thin peripheral sections and breakage of a blade under the action of thermomechanical and vibrational stresses

Solving this equation for $\lg N$ is quite difficult, but it is possible [8, 9]. The research shows that for tests with $N = 10^3 \dots 10^4$ cycles, $\sigma_{st\ opt} \approx 50 \dots 250$ MPa which increases the thermocyclic durability by factor 2... 3 compared to the symmetric cycle of thermocyclic stress.

Work (Kulik, et al., 2009b) devoted to the influence of the asymmetry of the thermomechanical load cycle on the durability of heatproof alloys in thermocyclic tests. In it is shown that the range of asymmetry of the thermomechanical load cycles of heatproof materials samples (range $-0.25 \dots -0.5$) in which (regardless of materials) plastic deformations are mutually compensated and almost do not accumulate. In this range the durability of materials and parts of them can be increased by factor 2...5. The latter conclusion requires additional theoretical and experimental research to substantiate it to new materials. But the reserves of thermocyclic durability of alloys are available and they should be used whenever it is possible (Vetrov, Koveshnikov, 1981).

As for creation of engine service life counters, using data of engine main high-stress parts actual technical state monitoring, it should be noted that in the program of the counters must be consider, along with the characteristics of long-term and vibration strength, also characteristics of thermocyclic durability. Then the thermocyclic durability of parts in complex conditions will be, though not very large, but correspond to the actual extreme operating conditions of the gas turbine engine.

3. Conclusions

1. Damages accumulation in high pressure turbines nozzle blades takes place in the area of maximum temperatures and thermocycling stresses.

2. In HPT rotor blades localization of damages is possible in three zones: under the bandage shelf, in the zone of maximum temperatures and in a root zone as result high temperatures and extreme thermomechanical stresses action.

3. To determine the thermocyclic durability of alloys and the service life of HPT blades it is not enough to use only of one-hundred-hour (or thousand-hour) long-term strength characteristics to calculate strength but it is necessary, first of all, to do special laboratory research and apply experimental characteristics of thermocyclic durability in identical (extreme) operating conditions.

4. Reserves of thermocyclic durability, i.e. HPT service life and also engine reliability should be defined not only by characteristics of alloys thermocyclic durability but also considering asymmetry of a cycle of stresses and plastic deformations in semicycles of heating and cooling during engine starts and stops.

References

- Kulik, M.S., Kucher, O.G., Koveshnikov, M.O., Dubrovs'kij, S.S., Petruk, Y.A., 2009. Lokalizaciya kritichnih zon poskodzhennya zharomicnih materialiv ta rotornih detalej gazoturbinnih dviguniv. Naukoemni tekhnologii. Nauk. Zhurnal, NAU, Kiiv, 2, 5-11.
- Kulik, M.S., Kucher, O.G., Koveshnikov, M.O., Dubrovs'kij, S.S., Petruk, Ya.A., 2009. Vpliv asimetrii ciklu termomekhanichnogo navantazhennya na dovgovichniy zharomicnih materialiv pri termociklichnih viprobuvannyah. Naukoemni tekhnologii. Nauk. Zhurnal, NAU, Kiiv 3, 9-19.
- Kulik, M.S., Kucher, O.G., Koveshnikov, M.O., Dubrovs'kij, S.S., Petruk, Y.A., 2010. Model' granichnikh napruzhen' pri termociklichnikh viprobuvannyakh na dovgovichniy zharomicznikh materi'ali'v. Naukoemni' tekhnologi'yi. K.: Vid-vo nacz. avi'acz. un-tu «NAU-druk» 1:5-15.
- Loziczkiy, L.P., Vetrov, A.N., Koveshnikov, N.A., A.S.SSSR.839022 Ustanovka dlya ispy'tanij materialov na termomekhanicheskuyu ustalost', KIIGA: Zayavl.05.03.1979. 2732866 / 25-28, Opubl. VBI, 1981, #38; MKZ 601 #3 / 60. UDK620.178.38 (088.8).
- Petruk, B.A., Deformaczi'jna spromozhni'st' avi'aczij'nikh zharomicznikh splavi'v ta yikh termociklichna dovgovichni'st'. Problemi tertya ta znoshuvannya. K.: NAU 2:92-97.
- Petruk, Y.A., 2016. Optimi'zaczi'ya czikli'chnogo termomekhanichnogo napruzhennya v kritichnikh tochkach detalej garyachoyi chastini gazoturbinnykh dvigunovikh ustanovok. Problemi tertya ta znoshuvannya. K.: NAU 2:86-91.
- Pridorozhnyj, R.P., Zin'kovskij, A.P., Sheremet'ev A.V., et al., 2011. O vliyanii polzuchesti na napryazhenno-dempirovanoe sostoyanie bandazhirovannykh rabochikh lopatok turbin. Prochnost' materialov i e'lementov konstrukcij: Tr. Mezhdunar. nauch.-tekh. konf. K.: In-t problem prochnosti im. G.S. Pisarenko NAN Ukrainy' 348-353.
- Sheremet'ev, A.V., 2012. Konstruktivnoe podobie v detalyakh aviacionny'kh GTD. Aviacionno-kosmicheskaya tekhnika i tekhnologiya 9.96:49-53.
- Sheremet'ev, A.V., 2018. Ob uchete mnogokomponentnogo nagruzheniya pri obespechenii prochnostnoj nadezhnosti detalej aviacionny'kh GTD. Vestnik dvigatelestroeniya 2:164-168.
- Vetrov, A.N., Koveshnikov, N.A., AS SSSR #1448370. Sposob obrabotki detalej, KIIGA: Zayavl. 1981 g. Opubl. VBN 1983. 4 s.