

# Wire Mesh Tomography System for Horizontal Two-phase Fluid Flow Investigation

Leong Lei Yeng<sup>1</sup>, Ruzairi Abdul Rahim<sup>1\*</sup>, Navintiran Rajan<sup>1</sup>, Mohd Shukri Manaf<sup>1</sup>, Mohd. Hafiz Fazalul Rahiman<sup>2</sup>, Anita Ahmad<sup>1</sup>, Yusri Md. Yunus<sup>1</sup>, Sallehudin Ibrahim<sup>1</sup>, Yasmin Abdul Wahab<sup>3</sup>, Mimi Faisyalini Ramli<sup>4</sup> and Suzanna Ridzuan Aw Abdullah<sup>5</sup>

<sup>1</sup>School of Electrical Engineering, Faculty of Engineering, Universiti Teknologi Malaysia, 81310 UTM Johor Bahru, Johor, Malaysia

<sup>2</sup> Faculty of Electrical Engineering Technology, Universiti Malaysia Perlis, Pauh Putra Campus, 02600 Arau, Perlis, Malaysia

<sup>3</sup> Faculty of Electrical & Electronics Engineering Technology, Universiti Malaysia Pahang, 26600 Pekan, Pahang, Malaysia

<sup>4</sup> Faculty of Technology Engineering, Universiti Tun Hussein Onn, Campus Pagoh, Johor, Malaysia

<sup>5</sup> Faculty of Electrical & Automation Engineering Technology, Terengganu Advanced Institute Technical College (TATIUC), Telok Kalong, 24400 Kemaman, Terengganu, Malaysia

\*Corresponding author: ruzairi@utm.my, Tel: 607-5537801

**Abstract:** Simultaneous flow of liquid and gas is commonly found in process industries, such as petroleum pipeline transport, chemical process, oil and gas pipeline transport and many more. Phase distribution monitoring and visualizing for such flow is important to ensure the operation safeness and effectiveness. This study aims to investigate wire-mesh tomography system on solid-free two-phase flow monitoring and visualization. Experiment was conducted on a horizontal liquid/gas flow with an inner diameter of 84mm. A 16 x 16 wire-mesh sensor was designed and applied in this study to obtained the raw data from the target flow. The sensor worked together with transceiver circuit and data acquisition and image reconstruction software to visualize the flow condition and void fraction. Tomogram images were resulted as the final results of this experiment.

**Keywords:** Process tomography, two-phase fluid flow, wire-mesh tomography system, wire-mesh sensor

© 2021 Penerbit UTM Press. All rights reserved

*Article History: received 25 May 2021; accepted 12 June 2021; published 15 October 2021*

## 1. INTRODUCTION

The rise of process industries and pipeline transports causing the needs of technology involvement on phase distribution monitoring and analysing. This is to provide a better visual on the flow condition and understanding phenomena occurred [1]. Furthermore, this also helps in constant monitoring and controlling processes.

Many phase distribution monitoring techniques has been designed in analysing multiphase flow, such as process tomography. Process tomography is a technique which involve in tomographic imaging, such as electrical resistivity tomography, electrical capacitive tomography, X-Ray and many more [2]. Each tomography imaging method has its benefits and drawbacks in different situation. Electrical process tomography, such as electrical impedance tomography which is generally low price compare to radiative methods, but it has sensitivity problem [3]. For radiative methods such as X-Ray tomography, they are benefits on their non-intrusive sensors, however they usually involve in bulky equipment and ionizing radiation occur which might affect humans

health[4]. Ultrasonic tomography is also a non-intrusive tomography sensor by measuring the incident of ultrasonic waves and objects[5]. Even though each process tomography imaging is experimented and studied by many scientific researches, none of them can be said to be universally applicable, they have significant flaws which might fail in different scenarios.

Wire-mesh tomography is one of the tomographic imaging methods. It is an intrusive sensor which results cross-sectional images of the multiphase flow at high spatial and temporal resolutions for phases with significantly difference in conductivity or capacitance[6]. Prasser et al. was the first to develop a wire mesh sensor in measuring void fraction of liquid and gas flow using conductivity approach[7]. In later years, wire mesh tomography is further developed and improved which allows the measurement of velocity, types of liquid flow, such as slug flow and bubbly flow and vertical flow.

Prasser et al. further improved data acquisition unit by increasing the allowing sampling frequency from 1.2kHz to 10kHz[8]. Then, Wangjiraniran et al. further improve wire mesh tomography system by involving digital video

camera to the experimental study[9]. Image processing algorithm is used in measuring the bubble size and velocity in a transparent pipe. This design able to only achieved 500 frames per second which is relatively lower frame rate comparing with previous Prasser's design.

From years to years, wire-mesh tomography is tested in multiple process flow condition, such as horizontal or vertical flow[10]. Artificial intelligence algorithm such as fuzzy logic also involved in improving the resolution of the reconstructed image. However, there is a trade-off by using complex image reconstruction algorithm, which is reducing the maximum framerate of the resulted images as more time are required in image reconstruction process [11].

In this experimental study, a wire-mesh sensor based on conductivity approach was designed to study two phase liquid and gas flow in a horizontal pipe. This paper reviews the principle of wire-mesh technique and details the methodology in data acquisition and image reconstruction.

## 2. WIRE-MESH SENSOR

### 2.1 Operation Theory

Wire-mesh sensor (WMS) is an intrusive sensor which identify the condition inside a pipeline by measuring the conductivity or capacitance of the fluid passing through.

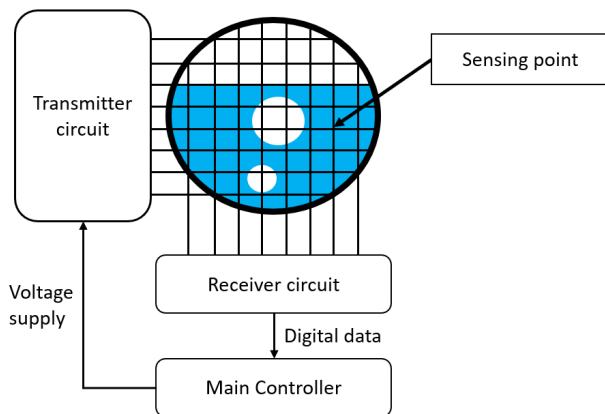

Figure 1. Simplified design of wire-mesh sensor

The two planes are aligned across the fluid's flowing direction. Each plane served a distinct purpose; transmitter plane and receiver plane. Transmitter plane is connected to the voltage supply terminal and the voltage supply while receiver plane is connected to the signal acquisition unit. Each crossover of wires on transmitter and receiver plane will be forming a sensing point and each of them represent one pixel on the reconstructed image.

The data or signal on the receiver plane will be acquired by the receiver circuit. An analog-to-digital converter (ADC) is applied to convert analog measurements into digital form. Next, main controller will receive and process the data and image reconstruction will be carried out to result a tomogram image of the water flow. Figure 2 shows an example tomogram result from a wire-mesh tomography system.

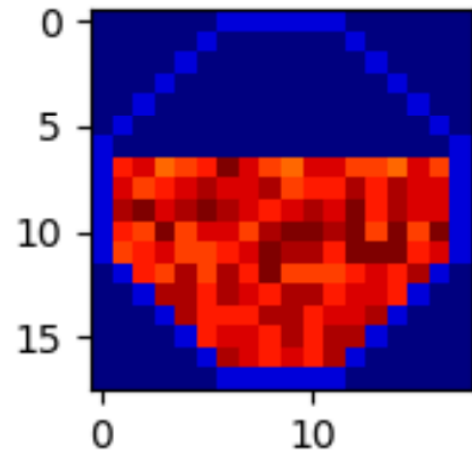

Figure 2. Reconstructed image of two-phase flow

### 2.2 Design of Wire Mesh Sensor

The wire-mesh sensor has two conducting planes which is formed by evenly arranged copper wires (Figure 3). The planes are placed perpendicular with a pitch distance,  $P=6\text{mm}$ . Each plane has a total of 16 copper wires with diameter,  $D=0.8\text{mm}$  and separated with a distance,  $d=4.5\text{mm}$  (Figure 4). Figure 5 shows the 3D design of the wire-mesh sensor fixture with a height,  $H=80\text{mm}$  and equal width and length,  $W=L=104\text{mm}$ .

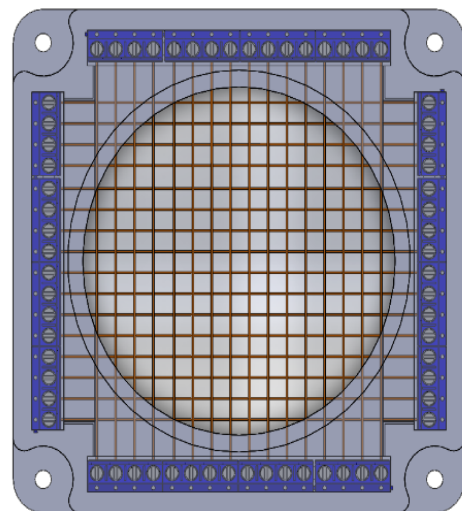

Figure 3. Top view of wire-mesh sensor

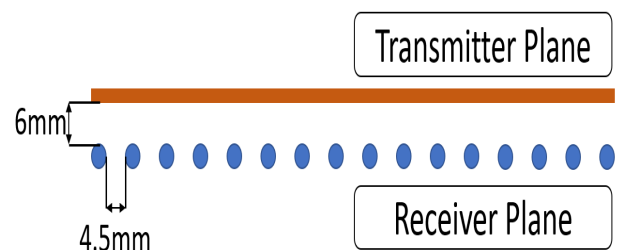

Figure 4. Dimension of wire-mesh sensor plane

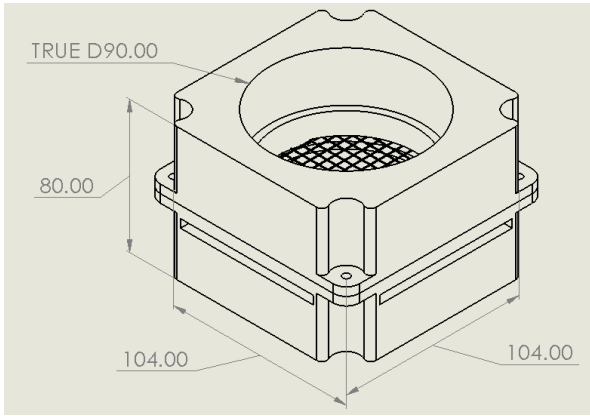

Figure 5. Dimension of wire-mesh sensor plane fixture

Two planes of 16 copper wires forming a total of 256 sensing points on the wire-mesh sensor. The wire-mesh sensor is attached to middle of two transparent Perspex process columns with an inner diameter,  $id=85\text{mm}$  and outer diameter,  $od=90\text{mm}$ . Since the process column is a cylinder, only a total of 216 sensing point will be useful in measurements. Two ways terminal blocks are used to connect the copper wires to the transceiver circuit boards.

The fixture is 3D printed as shown in Figure 6 using PLA filaments. The 3D printer was fully tuned with a tolerance of  $+0.2\text{mm}$ . The fixture is 3D printed into two parts which are then screwed together with four M4 bolts and nuts at each corner. Single core insulated wires are used in connecting the terminal blocks to the transceiver circuits. Figure 7 shows the self-fabricated PCB of the transceiver circuits.

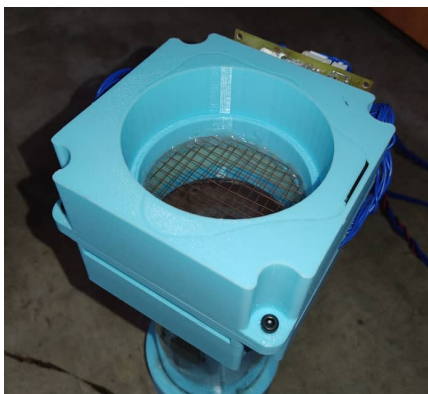

Figure 6. 3D printed wire-mesh sensor fixture

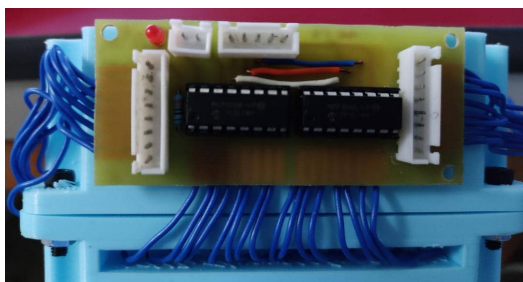

Figure 7. 3D printed wire-mesh sensor fixture

### 2.3 Electronic System of Wire-Mesh Sensor

The wire-mesh sensor adopts the measurement technique introduced by Prasser et al. This technique uses conductivity of fluid to conduct and varies voltage transferred to receiver plane[7].

Transmitter circuit consist of a connecting point between the main controller which is Raspberry Pi 400. A total of 16 general purpose input output port on the Raspberry Pi 400.

The logic output of Raspberry Pi only able to supply a maximum of 3.3V voltage supply through general input output pin, thus a level shifter circuit is used to leverage the 0V to 3.3V analog measurements to 0V to 5V measurements. Figure 8 shows the connection of a non-inverting operational amplifier circuit with a gain,  $A=1.51$  which is used as a level shifter in this condition. Gain of a non-inverting operational amplifier circuit can be calculated using Equation 1.

$$A = 1 + \frac{R_1}{R_2} \tag{1}$$

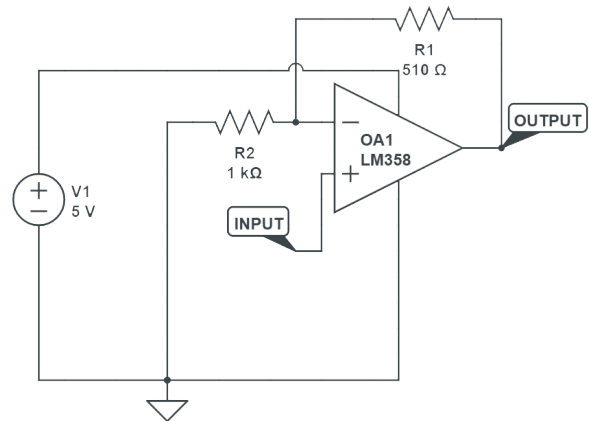

Figure 8. 3.3V to 5V level shifter circuit

Resistors,  $R_1$  and  $R_2$  should be as low as possible to reduce the resistor noise or thermal noise generated by themselves which might cause noisy or inaccurate result [12]. Op amp tends to be noisier at low frequency due to the existence of  $1/f$  noise from the op amp itself. Thus, it is importance in selecting low noise op amp[13].

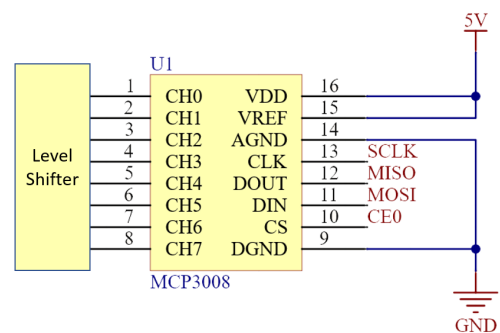

Figure 9. Connection between level shifter and ADC

Since Raspberry Pi only able to process digital signal, analog-to-digital converter is required in converting analog measurement from the level shifter to digital signal for further analysis and image reconstruction. Two 8 input channels ADC MCP3008 are used to cover the 16 receiver channels. Connection of MCP3008 with level shifter as shown in Figure 9. MCP3008 will convert the analog measurements to digital data and sent to Raspberry Pi through SPI connection with a maximum 12kHz sampling rate. Two ADCs share same SPI connection port, however each of them is connected with different chip select pin [14].

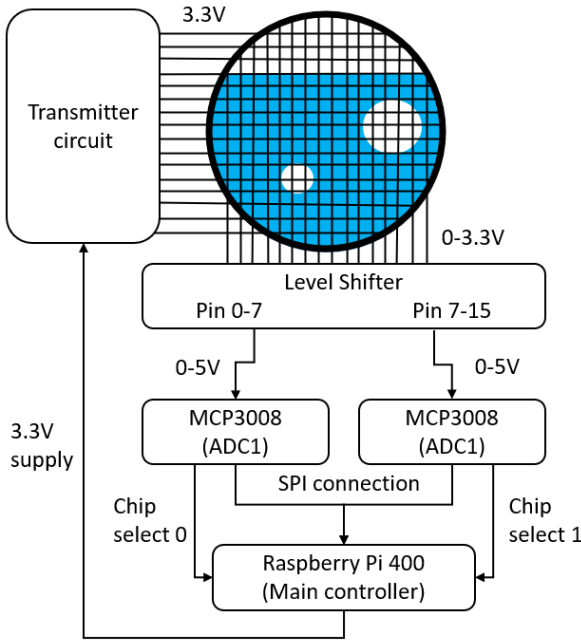

Figure 10. Block diagram of wire-mesh tomography system

Figure 10 shows the overall connection and communication within a tomography system between wire-mesh sensor and main controller. The measurements from the receiver plane will be acquired and send to Raspberry Pi for image reconstruction.

**2.4 Image Processing**

All the programming scripts are written in Python language as it is an open-source programming language with various library. The software system of wire-mesh system starts with generating excitation signal to the transmitter plane. 3.3V PWM excitation signal is supplied to the transmitter plane in fixed order and one at a time. The excitation signal changes from one wire to another once all 16 channels measurements on the receiver plane are acquired.

Python spidev library is used in acquiring data through SPI communication from MCP3008. All the data are stored in array or matrix for easier classification and calculation. Array of 18x18 dimension is used in data storing, where two extra rows and columns of the array are used in setting up the borders in separating active sensing nodes and passive sensing nodes. After 256 channels

measurements are successfully collected, it is sufficient to generate one frame of 2D tomogram result. The data are stored in array form and transferred to another python scripts for image reconstruction.

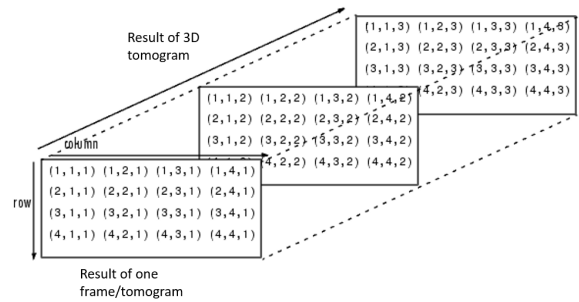

Figure 11. Example of result from the data acquisition software

To construct 3D tomogram result of the fluid flow, multiple 2D tomogram result is required. Thus, the data acquisition steps and excitation signal supply are repeated for few times in obtaining 3-dimension array as shown in Figure 11. Each 2-dimension array representing one set of data for one tomogram result.

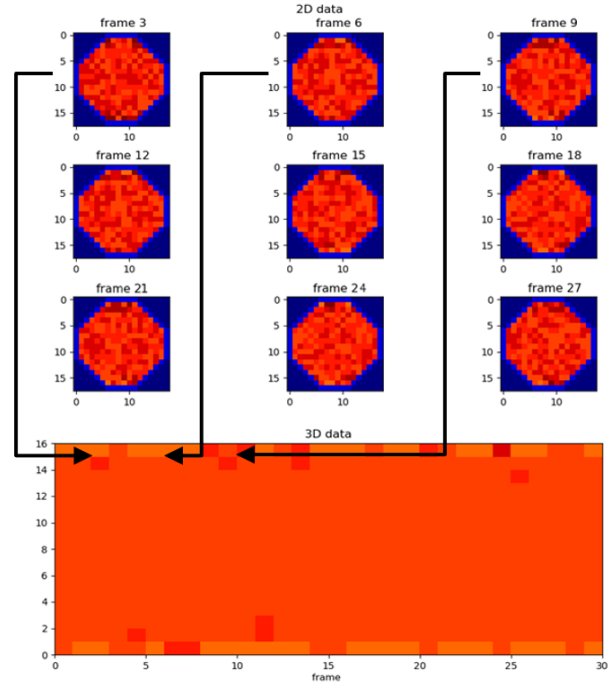

Figure 12. Formation of 3D tomogram result

Arrays from the data acquisition scripts will be mapped and converted into tomogram through image reconstruction scripts. Different colours are used in representing different conductivity measured by the wire-mesh sensor from the target fluid flow. Figure 12 shows the tomogram results after image reconstruction.

Simple algorithm is used in image reconstruction. The calculated conductivity of the fluid is mapped to respective colour according to jet colourmap. This is to reduce the processing time period in image reconstruction.

### 3. RESULTS AND DISCUSSIONS

For easier data acquisition and data collection, a GUI is designed for this experiment using python as shown in Figure 13. “Run” is button to initiate data acquisition scripts to collect data and “Download” button is to download the tomogram results reconstructed.

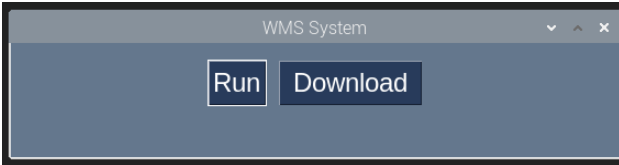

Figure 13. GUI of wire-mesh tomography system

Results of different void fraction were acquired and reconstructed. Nine frames of 2D tomogram results were displayed to show the changes of the fluid flow and void fraction. A 3D tomogram results fluid flowing condition while 30 frames of data were taken. Jet colourmap are used for clearer visualization on the phase distribution of the fluid flow.

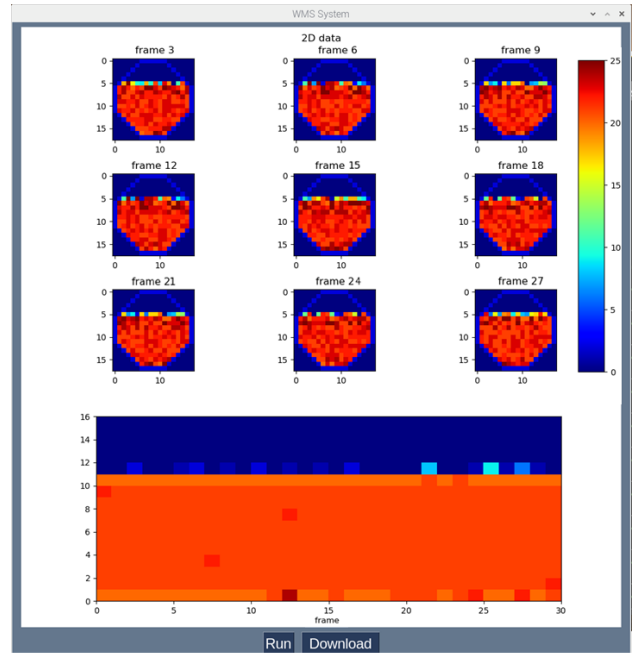

Figure 15. Tomogram results of 75% void fraction

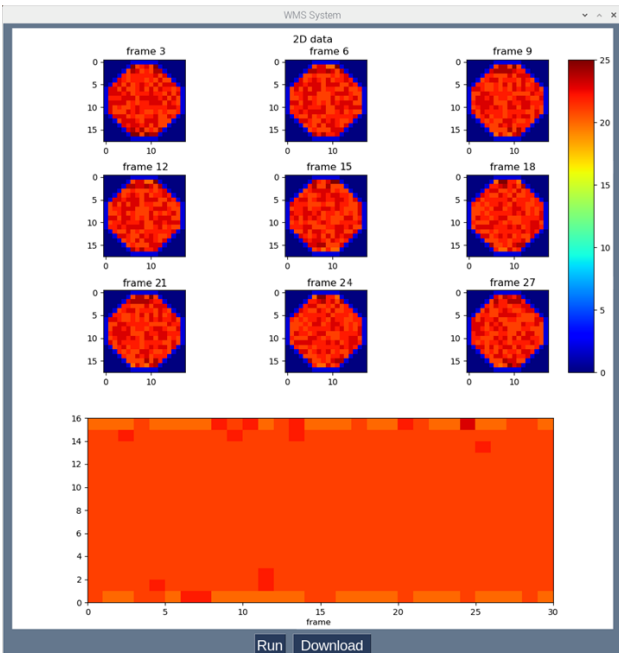

Figure 14. Tomogram results of 100% void fraction

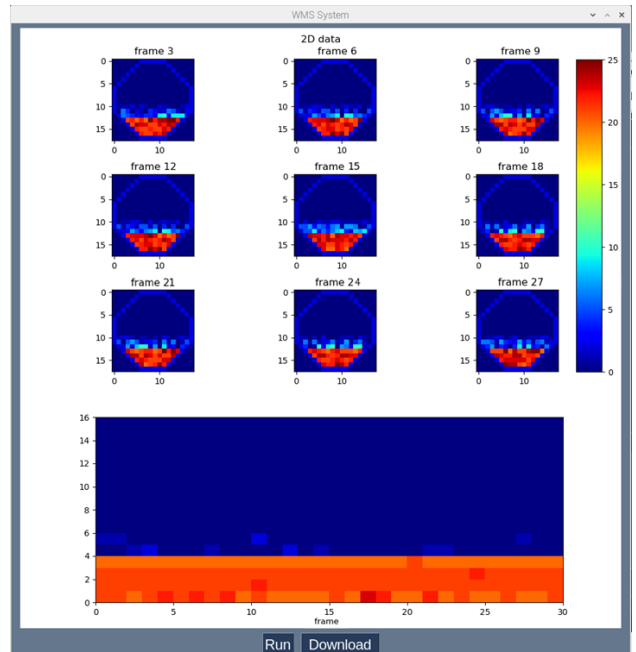

Figure 16. Tomogram results of 25% void fraction

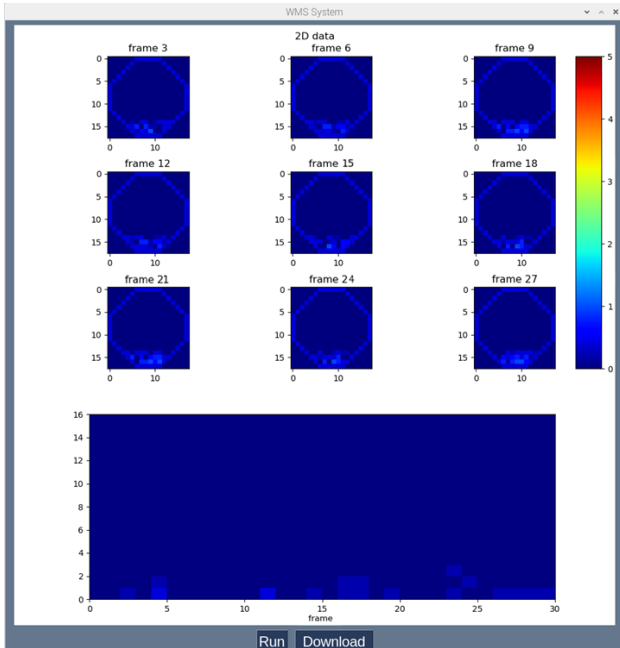

Figure 17. Tomogram results of 0% void fraction

Figure 14 clearly shows the pipe is fully filled with water. However, the acquired data are not stable and fluctuating. This is due to the unstable and unshielded wire connection between the receiver circuits and Raspberry Pi, causing an estimated  $\pm 3\%$  error.

Two distinct phases of liquid and gas flows are clearly shown in Figure 15 and Figure 16. But the measurements on the liquid surface are slightly inaccurate which causing the inaccurate

By referring to the data tomogram results in Figure 14, Figure 15 and Figure 16, the measurements around the borders of the wire-mesh sensor have higher error compared to the centre sensing point. However, the errors are small and acceptable in measuring phase distribution of two-phase flow.

The tomogram results of 0% void fraction shown in Figure 17 from the wire-mesh sensor shown an inaccurate result. This is due to slightly accumulation of water at the bottom of the sensor fixture and causing readings still exists.

Overall, the errors in the measurements are acceptable which is around  $\pm 3\%$ . However, the errors or the noise can be further reduced by using shielded wire and more stable wire connection. Besides, PCB of the circuit system should be properly shielded by adding ground pad on empty area.

#### 4. CONCLUSION

The paper presents the results of experimental study of wire-mesh tomography system in phase distribution imaging of two-phase liquid gas flow. The designed  $16 \times 16$  wire-mesh sensor is mainly powered by Raspberry Pi and Python was used as the main programming language throughout this study. Wire-mesh sensor assure efficient tomographic imaging on multiphase flow. This system can be further improved by using programming wise filtering system to further suppress noisy measurement. Besides, the image reconstruction algorithm also can be further studied for smoother reconstructed tomogram results.

#### ACKNOWLEDGMENT

The authors would like to thank to Universiti Teknologi Malaysia for supporting the research study under UTMER Research Fund, vot number QJ130000.3851.19J53.

#### REFERENCES

- [1] M. J. Da Silva, U. Hampel, L. V. R. Arruda, C. E. F. Do Amaral, and R. E. M. Morales, "Experimental investigation of horizontal gas-liquid slug flow by means of wire-mesh sensor," *J. Brazilian Soc. Mech. Sci. Eng.*, vol. 33, no. SPEC. ISSUE, pp. 237–242, 2011, doi: 10.1590/S1678-58782011000500005.
- [2] M. H. F. Rahiman, L. T. Siow, R. A. Rahim, Z. Zakaria, and V. Ang, "Initial study of a wire mesh tomography sensor for Liquid/Gas component Investigation," *J. Electr. Eng. Technol.*, vol. 10, no. 5, pp. 2205–2210, 2015, doi: 10.5370/JEET.2015.10.5.2205.
- [3] E. Santos and F. Simini, "Electrical Impedance Tomography for pulmonary oedema extent monitoring: Review and updated design," *J. Phys. Conf. Ser.*, vol. 407, no. 1, 2012, doi: 10.1088/1742-6596/407/1/012024.
- [4] C. Tompkins, H. M. Prasser, and M. Corradini, "Wire-mesh sensors: A review of methods and uncertainty in multiphase flows relative to other measurement techniques," *Nucl. Eng. Des.*, vol. 337, no. July, pp. 205–220, 2018, doi: 10.1016/j.nucengdes.2018.06.005.
- [5] N. MITA and T. TAKIGUCHI, "Principle of ultrasonic tomography for concrete structures and non-destructive inspection of concrete cover for reinforcement," *Pacific J. Math. Ind.*, vol. 10, no. 1, 2018, doi: 10.1186/s40736-018-0040-0.
- [6] A. Sujiwa and E. Endarko, "Wire-Mesh  $16 \times 16$  Capacitance Sensor for Analysis of Capacitance Distribution on Cylindrical Pipe," *IPTEK J. Proc. Ser.*, vol. 4, no. 1, p. 130, 2018, doi: 10.12962/j23546026.y2018i1.3524.
- [7] H. M. Prasser, A. Böttger, and J. Zschau, "A new electrode-mesh tomograph for gas-liquid flows," *Flow Meas. Instrum.*, vol. 9, no. 2, pp. 111–119, Jun. 1998, doi: 10.1016/S0955-5986(98)00015-6.
- [8] H. Prasser, E. Krepper, D. Lucas, and J. Zschau, "Fast Wire-Mesh Sensors for Gas-Liquid Flows and Decomposition of Gas Fraction Profiles According To Bubble Size Classes," pp. 41–58, 2001, [Online]. Available: [http://www.hzdr.de/FWS/FWSF/mtws\\_00/WS4\\_Zschau.pdf](http://www.hzdr.de/FWS/FWSF/mtws_00/WS4_Zschau.pdf).
- [9] W. Wangjiraniran, Y. Motegi, S. Richter, H. Kikura, M. Aritomi, and K. Yamamoto, "Intrusive effect of wire mesh tomography on gas-liquid flow measurement," *J. Nucl. Sci. Technol.*, vol. 40, no. 11, pp. 932–940, 2003, doi: 10.1080/18811248.2003.9715436.
- [10] T. T. Nguyen, H. Kikura, H. Murakawa, and N. Tsuzuki, "Measurement of Bubbly Two-phase Flow in Vertical Pipe Using Multiwave Ultrasonic Pulsed Doppler Method and Wire Mesh Tomography," *Energy Procedia*, vol. 71, pp. 337–351, 2015, doi: 10.1016/j.egypro.2014.11.887.
- [11] P. Wiedemann, F. de A. Dias, E. Schleicher, and U.

- Hampel, “Temperature compensation for conductivity-based phase fraction measurements with wire-mesh sensors in gas-liquid flows of dilute aqueous solutions,” *Sensors (Switzerland)*, vol. 20, no. 24, pp. 1–21, 2020, doi: 10.3390/s20247114.
- [12] C. Arnaboldi *et al.*, “Low-frequency noise characterization of very large value resistors,” *IEEE Trans. Nucl. Sci.*, vol. 49 I, no. 4, pp. 1808–1813, 2002, doi: 10.1109/TNS.2002.801507.
- [13] B. Carter, “Op Amp Noise Theory and Applications,” in *Op Amps for Everyone*, 1st ed., Texas: Texas Instruments Incorporated, 2003, pp. 10.1-10.25.
- [14] T. DiCola, “MCP3008 | Raspberry Pi Analog to Digital Converters | Adafruit Learning System.” <https://learn.adafruit.com/raspberry-pi-analog-to-digital-converters/mcp3008> (accessed May 19, 2021).