

World Maritime University

The Maritime Commons: Digital Repository of the World Maritime University

World Maritime University Dissertations

Dissertations

10-31-2022

Hazard analysis of hydrogen fuel cell ships using land based accidents data and elicitation of experts

Chahrazed Tigha

Follow this and additional works at: https://commons.wmu.se/all_dissertations



Part of the [Energy Policy Commons](#)

Recommended Citation

Tigha, Chahrazed, "Hazard analysis of hydrogen fuel cell ships using land based accidents data and elicitation of experts" (2022). *World Maritime University Dissertations*. 2070.
https://commons.wmu.se/all_dissertations/2070

This Dissertation is brought to you courtesy of Maritime Commons. Open Access items may be downloaded for non-commercial, fair use academic purposes. No items may be hosted on another server or web site without express written permission from the World Maritime University. For more information, please contact library@wmu.se.

WORLD MARITIME UNIVERSITY

Malmö, Sweden

**HAZARD ANALYSIS OF HYDROGEN FUEL
CELL SHIPS USING LAND BASED
ACCIDENTS DATA AND ELICITATION OF
EXPERTS**

By

**TIGHA CHAHRAZED
ALGERIA**

A dissertation submitted to the World Maritime University in partial
fulfilment of the requirements for the award of the degree of

**MASTER OF SCIENCE
in
MARITIME AFFAIRS**

(MARITIME SAFETY AND ENVIRONMENTAL ADMINISTRATION)

2022

Declaration

I certify that all the material in this dissertation that is not my own work has been identified, and that no material is included for which a degree has previously been conferred on me.

The contents of this dissertation reflect my own personal views, and are not necessarily endorsed by the University.

(Signature):

A handwritten signature in blue ink is written over a horizontal dotted line. The signature is stylized and appears to be 'C. Chae'.

Date: **30th September 2022**

Supervised by: **Dr.Chong-Ju Chae**

Supervisor's affiliation: **Assistant Professor- WMU**

Acknowledgements

In the beginning, I want to thank God for blessing me with such a wonderful life and for being my companion on this amazing path to wisdom. Through thick and thin, he has been by my side. If it weren't for God's grace, I wouldn't have the strength to embark on this adventure and learn to love its ups and downs. I will be forever indebted to Him.

It is a pleasure for me to express my heartfelt appreciation to my sponsor, the Nippon Foundation and Sasakawa Peace Foundation, for the wonderful opportunity to study at this prestigious University.

I would like to convey my deep appreciation to my supervisor, Professor Chong-Ju CHAE of WMU, for providing me with the opportunity to do research on this topic. He assisted me at every stage of this course and encouraged me to pursue excellence in my research.

I would like to express my deepest appreciation to my husband “Hichem” and to my lovely daughter “Eva Miral” as well as to the whole family for their unwavering support and for being the pillars on which I stand and the sources of my inspiration. Their sacrifices made it possible for me to get this point in my life.

Especially, I would like to thank my brothers “Fouad” and “Mohamed Ali”. I always feel I have support in whatever I do and I enjoy it. The motivation I receive from you all keeps me going.

I would also like to express my gratitude to my friend Nadhir kahlouche from WMU for providing me with ideas and supporting me during the research. I would like to express my gratitude to my wonderful classmates from MSEA as well as my friends from WMU who have provided moral support and who have helped to make the learning process enjoyable. In addition, I would like to extend my gratitude to everyone who took the time to answer, as well as the WMU academic, library, and residence staff members that helped make this wonderful experience possible for me.

Abstract

Title of Dissertation: Hazard analysis of Hydrogen fuel cell ships using land based accidents data and elicitation of experts.

Degree: Master of Science

Over the past few years, hydrogen has attracted a lot of attention. Even though industry interest is growing and a several studies have been launched, there are still numerous obstacles to overcome. The remaining challenges are primarily related to safety aspects, and there is, in a nutshell, a demand for greater more gaps in the use of hydrogen fuel cell in marine applications. The purpose of this study intends to contribute to the investigation of hazards associated with HFC in the shipping industry. The study investigates the existence of different hazards, their causes and consequences from various industry based on hydrogen incident database. In particular, it investigates the way the lesson learnt from previously available incidents contributes in creating such a foundation for safety measures in the shipping industry regarding the new technology of HFC. The study employed an exploratory HAZID study based on past incidents analysis. In addition to the qualitative exploratory part, the validity of the findings overcoming from the incidents database were assessed by elicitation from the experts. The study yielded four factors that can affect and jeopardise safety when HFC is used: Human error, management factors, equipment failure and other factors. In addition to four hazardous events which are: Leakage, source of ignition in the space, permeation and flooding that can negatively impact the safety performance as well as the operational aspects of ships. The study proposed several safety measures to remove or minimise the root causes expected in case of hydrogen leakage. Moreover, the study indicates that learning from previous incidents is an effective technique, particularly when data about the technology to investigate is so scarce. Such information gleaned from the investigation of occurrences may be of assistance in the process of risk assessment.

KEYWORDS: Hazard analysis, HFC, Sustainable fuel, Safety aspects, Incident database, safety measures, lesson learnt, Delphi rounds.

Table of Contents

Declaration	ii
Acknowledgements	iii
Abstract.....	iv
Table of Contents	v
List of Tables	vii
List of Figure	viii
List of Abbreviations	ix
CHAPTER 1: INTRODUCTION.....	10
1.1 Background	10
1.2 Problem statement.....	13
1.3 Aims and objectives	14
1.4 Research questions	14
1.5 Composition of dissertation	15
CHAPTER 2: LITERATURE REVIEW	16
2.1 Hydrogen Fuel Cell (HFC) in the maritime industry	16
2.2 Fundamental principle of fuel cells	19
2.3 Fuel cells in shipping application	22
2.4 Safety issues associated with HFC	26
2.5 Regulatory perspective of HFC use in shipping	27
2.6 Hydrogen technologies in the maritime industry	29
2.6.1 On-board end use	29
2.6.2 Fuel cells	30
2.6.3 Hazards of on-board use.....	30
CHAPTER 3: RESEARCH METHODOLOGY	34
3.1 Accidents database to support risk assessment process.....	34
3.2 Data Analysis of Hydrogen incidents from eMARS Database.....	37
3.3 Thematic analysis (TA).....	38
3.4 Barrier Analysis approach for accident prevention	38
3.5 Delphi methodology	39
3.6 Research design	41
3.6.1 Data collection	41
3.6.2 Interviews.....	42
3.6.3 Application of the Delphi method on the data collection	43
3.6.4 Expert selection	43
3.6.5 Delphi interview questions rounds.....	44
3.6.6 Expert judgment.....	45
3.6.7 Degree of agreement between experts' concordance	47
3.7 Reliability and validity.....	47
3.8 Ethical Consideration	48
CHAPTER 4: DATA ANALYSIS	49
4.1 Thematic analysis	49

4.2	Management Oversight and Risk Tree	49
4.3	Statistical analysis.....	50
4.4	Data analysis through Delphi study	52
4.4.1	Delphi round 1	52
4.4.2	Delphi round 2	54
4.4.3	Delphi Round 3	57
4.5	Barrier Analysis	59
CHAPTER 5: DISCUSSION AND LIMITATION		61
5.1	Discussion of the findings.....	61
5.2	Limitation.....	64
CHAPTER 6: CONCLUSIONS & RECOMMENDATIONS		65
6.1	Conclusions	65
6.2	Recommendations.....	68
Reference		70
Appendices.....		79
Appendix A: WMU Research Ethics Committee Protocol		79
Appendix B: Personal Interview		80
Appendix C: Screenshot of excel eMARS Database		83
Appendix D: Expert questionnaire (Round one)		85
Appendix E. Expert questionnaire (Round two)		87

List of Tables

Table 1. Fundamental properties of hydrogen .	18
Table 2. Hydrogen accident data bases	35
Table 3. Scale for estimation probability of occurrence	46
Table 4. Scale used to estimate the severity of consequence	47
Table 5. Classification of accidents causes	49
Table 6. Feedback results of the expert questionnaire (round one)	54
Table 7. Feedback results of the expert questionnaire (round two)	55
Table 8. PO of the hazard Rankings $r_{i,j}$ in Delphi round 2 (m=6)	56
Table 9. Calculation the Kendall's coefficient of concordance W (round 2)	57
Table 10. Group Ranking of PO in round 2	57
Table 11. Severity of consequence Rankings $r_{i,j}$ in Delphi round 3 (m=6)	58
Table 12. Calculation the Kendall's coefficient of concordance W (Round 3)	58
Table 13. Consequence group rankings according to the third round's mean ranks.	59

List of Figure

Figure 1. Symbolic representation of individual generic fuel cells.	200
Figure 2. Principal fuel cell system components.	22
Figure 3. Maritime fuel cell project numbers since 2000.	25
Figure 4. Research methodology design.....	34
Figure 5. Multiple sources of evidence.....	41
Figure 6. Frequency distribution of the causal factors of hydrogen accidents in the industry (N=158).....	51
Figure 7. Frequency distribution of consequences of hydrogen accidents in the industry(N=103).....	51
Figure 8. Hazards associated with the use of Hydrogen in the industry (data analysis of 140 accidents on eMARS database)	52
Figure 9. Occupation of Delphi participants.....	53

List of Abbreviations

ACUsafe	US Chemical Safety Board Monitored Database
ARIA	Analysis, Research And Information On Accidents
ARIP	Accident Release Information Program
DS	Dangerous Space
eMARS	Major Accident Reporting system
ERNS	Emergency Response Notification System
FACTS	Failure Accidents Technical Information System
HIAD	Hydrogen Incident And Accident Database
HIRD	Hydrogen Incident Database
HFC	Hydrogen Fuel Cell
HTPEM	High Temperature Fuel Cells Powered By Methanol
IMO	International Maritime Organization
MCFC	Molten Carbon Fuel Cell
PEM	Proton Exchange Membrane
PO	Probability Occurrence
SOC	Severity of Consequence
SOFC	Solid Oxide Fuel Cell
SOLAS	Safety Of Life At Sea
WMU	World Maritime University

CHAPTER 1: INTRODUCTION

1.1 Background

Organizations and industry are collaborating to curb climate pollution across all sectors, as rising CO₂ level contributes to global warming. Globally, maritime industry use of energy was estimated at 19% in 2015. This figure is expected to hold steady in 2040, according to data from the US Energy information administration (EIA) (EIA, 2017). In fact, 90% of world trade is shipped by sea in which more than 56,000 merchant vessels operate on a global scale (“merchant fleet”, 2021). In particular, 99 % of the world's fleet is propelled by internal combustion engines with fossil fuels (Rattazzi et al., 2021).

According to recent data conducted by the International Maritime Organization (IMO), 300 million tons of fossil fuels are used annually (Ammar, 2019). Within the period from 2012 to 2018, IMO recorded a rise in green house (GHG) emissions of 977 million tons to 1076 million tons and CO₂ emissions from 962 million tons to 1056 million tons (Wijayanto, 2020). Therefore, it is estimated that around 3.1 % of the total CO₂ emissions is attributed to ship emissions (Balcombe et al., 2019), and if business as usual continues, IMO predicts 50 to 250 percent CO₂ emissions by 2050 (Linstad et al., 2015). Thus, recent IMO efforts and regulations require minimizing as much as possible CO₂ and GHG emissions.

As part of this, the energy efficiency regulations were properly established to address CO₂ issues, and this resulted in the creation of the mandatory Energy Efficiency Designs Index (EEDI) for new ships, which promotes the use of more energy-efficient equipment and engines. Moreover, some energy efficiency techniques are introduced to increase the energy efficiency of ship in a value manner as demonstrated by the Ship Energy Efficiency Management Plan (SEEMP) and the following Energy Efficiency Operational Indicator (EEOI). This latter, EEOI, was adopted for the purpose to underline the voyage efficiency by taking into account the

ton CO₂ per ship (Yalcin et al., 2020). Furthermore, the IMO decided in 2018 to develop an initial strategy to address the environmental problem of greenhouse gas (GHG) emissions caused by shipping activities. The goal of this strategy is to gradually eliminate GHG emissions from international shipping (Yalcin et al., 2020).

Despite the fact that there are various ways to achieve decarbonisation, the utilisation of alternative fuels still appears in all of the strategy terms. The use of batteries is also a solution to fulfil the global climate goals, as stated by Mao et al (2021). In this essence, the H2020 project TrAm of the European Union has resulted in the development of battery-powered vessels that have demonstrated their compliance with the IMO's GHG reduction requirements. Another friendly energy source is hydrogen, which has gained a lot interest during the latest years in the maritime sector (Georgeff et al., 2020). One main advantage of hydrogen is that can be produced in a sustainable manner through renewable energy, and it is an emission free of greenhouse gases when used. These alternatives are indeed promoting the complete decarbonizing for maritime transport (Inal et al., 2018).

For more than half a century, hydrogen has been applied as fuel, most prominently in space missions as rocket fuel (Granath, 2017). However, hydrogen has recently been exploited to power automobiles, buses, trucks, and ferries (Hall et al., 2018). It is available as a compressed gas (CH₂) or a liquid (LH₂) and can be utilized in either a fuel cell or an internal combustion engine (ICE). In 1842, William Grove invented the use of a fuel cell as a generator of electricity (Basu, 2007). Fuel cells have not been generally considered for general application due to the success and efficiency of combustion engines. Furthermore, fuel cells have only lately been used in specialized applications like space exploration and submarines. Due to the stringent emission regulations in the shipping industry, there has been an increased emphasis on the development of fuel cells as a viable option due to their high efficiency and low emissions (Inal et al., 2018). By eliminating NO_x, SO_x, and particle (PM) emissions and substantially reducing CO₂ emissions, fuel cell propulsion can meet current environmental regulations and ensure the sustainable development of the shipping

industry. Long-term use of hydrogen fuel derived from renewable energy sources could produce carbon-neutral ships (Linstad et al., 2015).

Currently, shipping faces the difficulty of diversifying the available fuels for on-board use (Tronstad et al., 2017). The use of this type of fuel, which has a low flash point, on ships necessitates the implementation of numerous requirements in order to comply with maritime regulations. Regarding hydrogen and fuel cells, the review of maritime regulations revealed that there are currently no internationally accepted regulations for the use of this new technology (Tronstad et al., 2017). However, there are regulations and guidelines that are of relevance for the concept installation. The International Code of Safety for Ship Using Gases or Other Low-flashpoint Fuels, IGF Code, is one of the primary codes that regulate safety instruction for the use of gases or other substances with a low flashpoint (Linstad et al., 2015). This latter establishes the specifications for the design and operation of liquefied natural gas-fuelled ships. However, it should be noted that there are no prescriptive regulation specifically addressing the safety use of HFC insulation. Additional zero-emission technologies could be a solution for ships, but they pose new safety concerns and obstacles in the construction of ships, including weight limitations and internal arrangement restrictions (Linstad et al., 2015).

Many attempts are being undertaken to gain a better knowledge of hydrogen safety concerns while dealing with fuel cells for use in shipping applications. To use HFC safely, however, additional regulatory standards must be developed. Led by DNV, 26 major associations and organizations have published a handbook on hydrogen-powered vessels in an effort to shed light on the most pressing regulatory issues surrounding hydrogen as a ship fuel cell. In addition, the MarHySafe joint development project (JDP) has been established to enhance knowledge of the safety of hydrogen operations in shipping, including the regulatory framework that addresses knowledge gaps regarding the safe handling, storage, and bunkering of hydrogen, as well as hydrogen's unique properties that make it difficult to manage (Linstad et al., 2015).

HFC technologies have many hazards and risks associated with them. Not least, a catastrophic failure in any HFC project could harm the stakeholder's opinion of HFC and hinder the capacity of HFC technologies to obtain insurance clearance, which is a prerequisite for commercialization. Therefore, the successful transition to hydrogen fuel cells is highly dependent on the assessment of HFC safety and associated risks that are likely to occur on ships. Additionally, as mentioned previously, there are no specific rules and regulations governing the use of HFC on ships. Aside from this, there are only a few of standard risk assessment methodologies for evaluating the risks associated with the use of hydrogen and fuel cells in maritime applications.

1.2 Problem statement

As the number of ships expected to be deployed in the future rises, so does the importance of understanding the risks and repercussions of maritime incidents involving hydrogen fuel cell as a preventative measure to eliminate the dangers. With regard to Hydrogen use on merchant ships, unless appropriate safety measures and practices are implemented, the properties of hydrogen may increase the overall risk aboard ships relative to other fuels. When hydrogen fuel and fuel cells are used on ships, especially in enclosed spaces such as fuel cell space and hydrogen storage space, there is a risk of low flash fuel leakage, which poses a fire and explosion hazard. As a direct result, hydrogen safety and leaks have attracted a great deal of attention, which requires prompt resolution. Notwithstanding, hydrogen has been put to work in a variety of other transport applications such as light duty vehicles, buses in tunnels or hydrogen refuelling station across. This means that regulations, standards and codes covering industrial use are already in place. In maritime context, the global maritime community trend towards reducing air pollution from ships has highlighted a new focus on the use of HFC to propel vessels. However, there is a lack in regulations about this new technology in the maritime context. The question that emerges from this statement is as follows: How can the use of HFC on board ships be achievable without compromising maritime safety?

1.3 Aims and objectives

The purpose of this study is to analyse hazards associated with the use of HFC in ships. The paper first discusses the potential dangers that could arise from using HFC as a powered fuel. Based on previous accidents that have been occurred in various industries, a hazard identification (HAZID) analysis will be conducted to investigate the root causes and consequences of hazardous events that may happen on board HFC ships. Then, the study will attempt to identify possible safety barriers that need to be incorporated into the maritime system. The research could facilitate policy makers to integrate the new technology in decarbonisation goals without jeopardising the safety in maritime application.

1.4 Research questions

Any new technology introduced into the maritime industry is required to undergo extensive research and development before it can be implemented on ships. This is done to ensure that the potential hazards posed by the new technology are not significantly greater than those posed by the technologies already in use. In this study, the following questions will be addressed as bellow:

1. What are the risks associated with the future operation of Fuel-cell powered ships?
2. What is the perception of maritime professionals regarding the risks that might be linked to the use of HFC on board ships?
3. What are the lessons learned from accident data of fuel cell technology in other industries to assess the risks of fuel-cell powered ships?
4. What are the safety measures that can be implemented to navigate safely on board HFC vessels?

1.5 Composition of dissertation

There are six sections to the dissertation. Chapter one contains the background, the problem statement, the aim and objectives, and content of the dissertation. The second chapter is a literature review that primarily explores the topic of hydrogen and fuel cell, with a special emphasis on safety concerns in maritime application. The methods, such as how the Delphi rounds and interviews were conducted, as well as how to conduct an exploratory HAZID study based on past knowledge from various industries, are described in Chapter 3. Besides the results of Delphi Rounds, chapter four describes and analyses accidents involving hydrogen on the EMARs database. The chapter 5 discusses the finding of the research and its limitation. The final chapter draws some final conclusions and make some suggestions for the future of the research.

CHAPTER 2: LITERATURE REVIEW

2.1 Hydrogen Fuel Cell (HFC) in the maritime industry

Due to the various challenges that are harming the environment, tightened emissions control have been set for more sustainable future with zero carbon content in various industries. The International Maritime (IMO), a specialised agency of UN responsible to regulate environmental protection for shipping internationally, is seeking to halve GHG emissions from international shipping by 2050 and, to more extent, eliminating them completely in the 21 century (Georgeff et al., 2020). For this concern and for the purpose of keeping international shipping safe, environmentally friendly, energy efficient and secure, IMO has recently been focussed on a regulatory framework necessary for a green and sustainable maritime transportation. A paradigm shift has opened the door to new alternative propulsion options as the maritime industry evolves.

Many vessels are sailing the world carrying out the global supply chain that society depends upon. Whilst maritime activities being recognized as an effective means of transportation, fossil fuels are still in use to propel 99% of the worldwide fleet, which has led to serious emission concerns regarding pollutants and greenhouse gases (IMO, 2014). Based on some statistics, 2.9% of global greenhouse gases are emitted by ships in all kind of categories, making the shipping industry hard to abate (Georgeff et al., 2020). Despite all the efforts, there are increasing amounts of carbon dioxide (CO₂), sulphur oxides (SOX), nitrogen oxides (NOX), particulate matter (PM), methane (CH₄), nitrous oxide (N₂O), and other harmful gases that are released as exhaust gases generated by the combustion of fossil fuels in marine engines (IMO, 2014). These emissions have dangerous effects on people and the environment. If the maritime community remain abstaining to mitigate such issues, there is a high expectation that emissions will increase further due to many factors such as the global economic growth, increase in international trade, and the need of shipping demand.

In terms of sustainability of shipping activities, fossil fuel use poses a serious problem. This has led to an increase in the development of new propulsion systems in recent years (Inal et al., 2022). In this regards, introducing hydrogen fuel cells (HFCs) as a power source for marine propulsion is viewed as a promising solution for completely decarbonizing maritime transport (Inal et al., 2022). In comparison to land-based industries, the HFC technology have demonstrated a certain level of acceptance in terms of construction technology and operating parameters (Spada et al., 2018).

Potential benefits of the use of HFC have been investigated, mainly including no pollution, high efficiency, great energy density, favourable stability and low noise (Borman, 1998). Due to the portfolio's advantages cited previously, it has gradually attracted a great deal of attention in the shipping industry. Moreover, the application of hydrogen fuel cells in vessels has promoted the development of clean energy (Inal et al., 2022). Currently, the HFC technology is being used on a few vessels, such as Viking Lady, Alsterwasser, Tianxiang, SF BREEZE and others (Li et al., 2018). From the perspective of clean energy propulsion, these vessels have been dubbed as the most environmentally friendly in history.

From a safety standpoint, the risks associated with the use of HFC aboard ships have not yet been adequately addressed for two reasons: on the one hand, there is a lack of understanding of hydrogen safety in such complex environments due to the novelty of the product and its limitations in commercial shipping (Li et al., 2018). On the other hand, as indicated by number of studies, fuel cell technologies pose unique safety challenges compared to conventional fuels (Spada et al., 2018). Consequently, safety is a crucial aspect that must be addressed during the period of maritime decarbonisation, necessitating the development of proactive responses to emerging risks and the continuation of current procedures for well-known dangers.

Hydrogen (H₂) properties include high leakage and diffusion, low ignition energy, large spectrum of fuel explosions and powerful explosion energy (Rigas et al., 2012), volume fraction of ignition throughout a range 4–74%, explosion volume fraction ranged from 18 to 59%, and minimum ignition energy of 0.02 m J (Rigas &

Amyotte, 2012). The hydrogen when it leaks can therefore reach easily other compartment due to its high diffusion characteristics, and consequently, there would be extremely severe issues resulting from series of chain reactions such as fire and explosion. Additionally, hydrogen is a colourless gas. It exists as a diatomic molecule when it is in its natural condition. There are two types of isotopes that can be found in hydrogen: simple hydrogen and heavy hydrogen, which is known as deuterium. However, the super-heavy form of hydrogen, known as tritium, decays radioactively and is therefore almost never encountered in nature. As a result, it is important to focus on safety aspects when a hydrogen fuel cell is being deployed to ships. The fundamental properties of hydrogen are presented in Table 1.

From ship's point of view, When HFC technology is applied as new system of propulsion, a very specific method is applied in order to classify the hazardous zones where unwanted events may occur. It is highly important to indicate that the fuel cell space and the hydrogen storage space are regarded as hazardous areas because of high the high possibility of leaks that might occur in both areas (Tronstad et al., 2017). Many authors focused on the application of several fuel cell powered ship projects in Europe, put forward different design schemes, and compared the efficiency and economy (Ghenai et al.,2019). Among others, Vogler (2009) compiled a number of instances of fuel cell-powered ships and suggested some general precautions to avoid hydrogen fuel leakage.

Table 1*Fundamental properties of hydrogen*

Property	Hydrogen
Density at 1 atm and 300 k	0,087 Kg /m ³
Stoichiometric composition in air	9,48 vol.%
Lower heating value	46.72 MJ/Kg
Minimum ignition energy	0,28 mJ
Laminar flame speed at NTP	0,16 m/s
Auto ignition temperature	550°C
Stoichiometric air fuel ratio	34.5:1
Adiabatic flame temperature	2214°C
Mass diffusivity in air	0.06 cm ² /s

Note. Adapted from *The hazards and risks of hydrogen*, by Crowl, D. A., & Jo, Y. D. (2007), *Journal of Loss Prevention in the Process Industries*, 20(2), 158-164, (<https://doi.org/10.1016/j.jlp.2007.02.002>).

2.2 Fundamental principle of fuel cells

Fuel cells are electrochemical devices that convert the chemical energy in fuels directly into electrical energy (Baroutaji et al., 2019). Fuel cells are not limited by the thermodynamic constraints of heat engines, such as the Carnot efficiency of a heat engine, due to the absence of heat and mechanical work generation (Baroutaji et al., 2019). Due to the absence of a combustion process, fuel cells generate electricity while emitting minimal pollution (EG&G, 2004).

The fundamental physical structure of standard fuel cells is depicted in Figure 1. A fuel cell is composed of an anode (negative electrode) and a cathode (positive electrode) encasing an electrolyte (Larminie et al., 2003). The cathode receives oxygen and the anode receives fuel. When activated by a catalyst, hydrogen atoms split into protons and electrons (Larminie et al., 2003). The external circuit is traversed by electrons, resulting in the flow of electricity. Electrolytes transport protons to the

cathode. When protons recombine with oxygen and electrons, they produce water and heat (IEA, 2004).

Figure 1

Symbolic representation of individual generic fuel cells

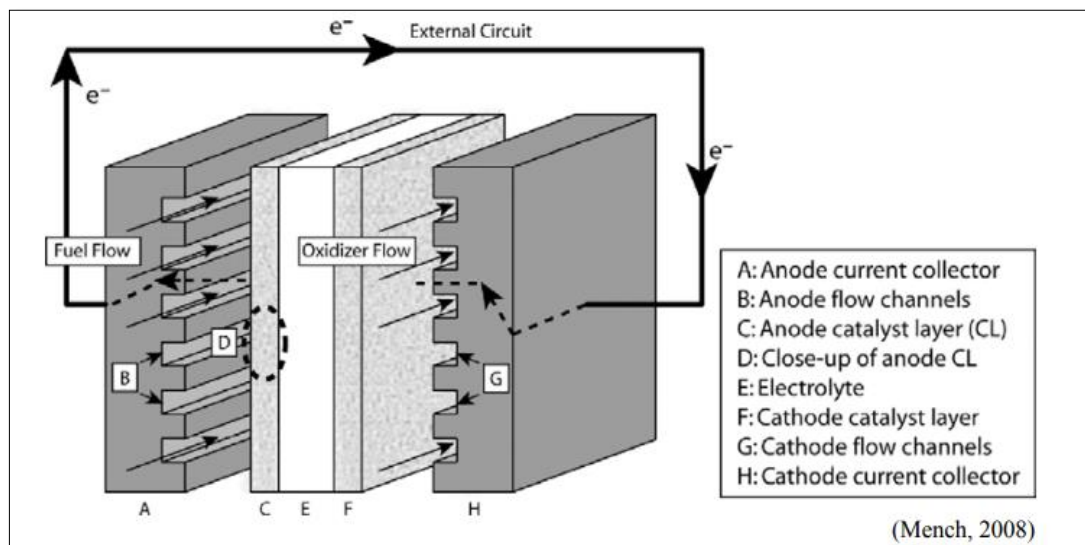

Note. Adapted from *Fuel cell engines*. John Wiley & Sons by Mench, M. M. (2008).

As shown in Figure 2, fuel cell power systems typically include three main components, namely H₂ storage, Fuel Cell Power Stack, and a DC/AC Power Inverter (Larminie et al., 2003). In stacks of fuel cells, individual cells are electrically connected to produce units with the desired output capacity. Theoretically, increasing the electrode surface area and reactant flow rate enables a single fuel cell to generate any amount of current and power. However, due to electrochemical potential limitations, the output voltage of individual fuel cells operating under realistic conditions is always less than 1 volt. Consequently, a stack of fuel cells consists of a series of connected individual cells. The Balance of plant (BoP) includes the following elements:

- Feed stream modification (including a fuel processor if needed): Before delivering hydrogen-rich gas to the fuel stack, the fuel processor or reformer must convert fuel to hydrogen-rich gas and purify it;
- Air delivery: it includes air compressors or blowers and air filters in the majority of practical fuel cell systems;
- Temperature control: all fuel cell systems require stack temperature management;
- Control of water resources: water is a reaction product and a requirement in some fuel cell areas. Most fuel cell systems need water management systems to prevent adding water to fuel and ensure smooth operation; and
- DC/AC Power Inverter: It converts fuel stack electricity into the desired output. After installing voltage and power monitoring and control devices, DC current can be drawn straight from the stack. Fuel cells generate direct current (DC). If AC is needed, the power conditioner includes an inverter.

This latter, the fuel cell controller, controls start-up power, stack cooling, gas flow, and close-down operation during power and hold on. Microprocessors and sensors measure temperature and gas flow. Most fuel cell systems' weight, volume, and cost come from their batteries (BoP) (Larminie et al., 2003).

Figure 2

Principal fuel cell system components

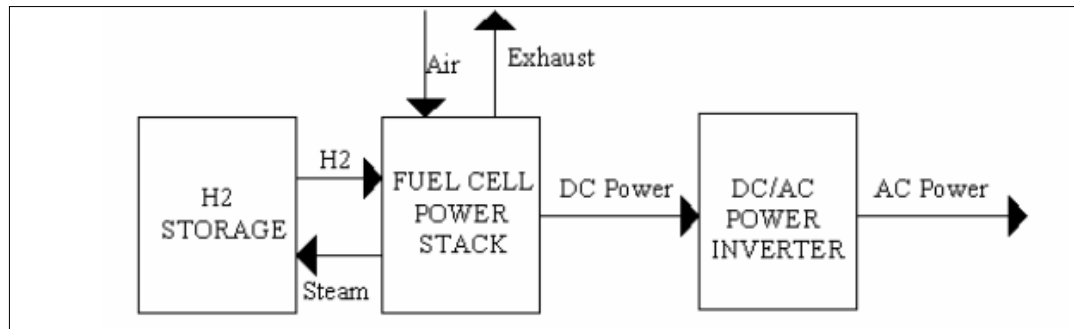

Note. Adapted from *Design of a PEM fuel cell system for residential application.* by Gencoglu, M. T., & Ural, Z. (2009), *international journal of hydrogen energy* 34(12), 5242-5248, (<https://doi.org/10.1016/j.ijhydene.2008.09.038>).

2.3 Fuel cells in shipping application

As with many new technologies, military research inspired fuel cells. Despite being discovered in the early 1800s, the principle was not applied until the mid-20th century (Larminie et al., 2003). US Navy fuel cell research began in the 1960s. In contrast, the German submarine industry and the Ministry of Defense came to the conclusion in the 1970s that fuel cells provided the most efficient solution for air independent propulsion (AIP) for electric diesel submarines. This made it possible for the submarines to remain submerged for longer periods of time (Mart& Margeridis, 1995). The Canadian Department of National Defence (DND) has been involved in the development of PEMFC technology since the mid-1980s (Weaver, 2002). UTC developed an alkaline fuel cell system for a US Navy deep submergence search vehicle. Deep Quest was equipped with UTC 30 kW alkaline fuel cells in 1978. Congress (1986) and Andudjar (2009) said Bacon developed fuel cells for submarines during World War II, but a paper shows the British Royal Navy adopted PEM technology in the 1980s (Smithsonian, 2004).

Compared to land-based applications, fuel cell adoption in surface ships is slow. Fuel cell research on surface ships began in 1996. Within this year, the German Mussel Fishers Association decided to equip their fleet with eco-friendly propulsion. Fuel cells can replace diesel generators. In 1997, the Office of Naval Research (ONR) began developing a ship service fuel cell (SSFC) module. 2004-EG&G Several FC-powered passenger vessels have been developed and demonstrated in response to the growing number of lakes in Europe where internal combustion engine-powered motor boating is restricted or banned to prevent pollution. In Switzerland, a pedalo-style boat powered by PSI's 100 W PEMFC stack was the first prototype. In Finland, Hydrocell Oy demonstrated a small fuel cell-powered boat (Weaver, 2002). EU started the FCSHIP project in July 2002 for two years. The Norwegian Ship-owners Association leads the 21-member project consortium. Most fuel cell demonstrations involve sailboats or yachts. Yuasa Corporation Japan used DMFC to power the 5.8-meter Malt's Mermaid III sailboat in 2002 (Cropper, 2004). MTU CFC unveiled a 12-meter PEM-powered sailboat in October 2003. The vessel is powered by a 20-kW unit co-developed with Ballard. She can travel 225 km at 6 km/h and is the first fuel cell-powered vessel to receive GL certification. Haveblue XVI sailboat prototype debuted in 2005 (Adamson, 2005). Voller installed their Emerald PEM APU on a Beneteau Oceanis yacht for fuel cell engineering trials in 2007. Icelandic New Energy supervised the installation of the Smart H2's hybrid hydrogen fuel cells APU (Hydrogen, 2008).

The UNIDO International Centre for Hydrogen Energy Technologies in Turkey contracted Hydrogenics to supply six 30 kW PEMFC power modules for a 50-passenger sightseeing boat (McConnel, 2010). The Viking Lady is the first commercial vessel with marine fuel cells. On April 29, 2009, Eidesvik Offshore got the Viking Lady. DNV classifies the ship as a North Sea supply vessel. Viking lady is the result of the 2003 FellowSHIP project, which aimed to develop power packs that reduce CO₂ emissions by up to 50% and increase energy efficiency by up to 30%. Nitrogen oxides, sulphur oxides, and particles will be completely eliminated. FellowSHIP also includes

power integration, safety and reliability studies, approval, and rule development (Facts, 2009).

The Dutch green tug project and Smit E3 Tug are others. Hydrogen and fuel cell technology benefit from a National Innovation Program (NIP). The NIP's first marine R&D project is e4 ships. It began in July 2009 and ends in 2016. Its goal is to show that fuel cells can work in ships' power supply systems under everyday conditions to promote cleaner energy generation in merchant shipping (IMO, 2009). The project involves 17 German institutions, including shipyards and shipping companies, fuel cell manufacturers, universities, associations, and classification organizations like GL, DNV, MTU On-site energy, and ZBT (e4ship, 2009). In June 2010, 20 kW SOFC was installed in Undine.

METHAPU is a consortium of Wartsila, Wallenius Marine, Lloyd's Register, Det Norske Veritas (DNV), and the University of Genoa in Italy. The project aims to validate and demonstrate new technologies that can reduce ship emissions. Also, it aims to establish international regulations for using methanol on commercial ships and as a marine fuel (Tronstad, 2017). This could indicate the emergence of fuel cells as a technology to solve environmental issues and their growth potential.

Figure 3

Maritime fuel cell project numbers since 2000

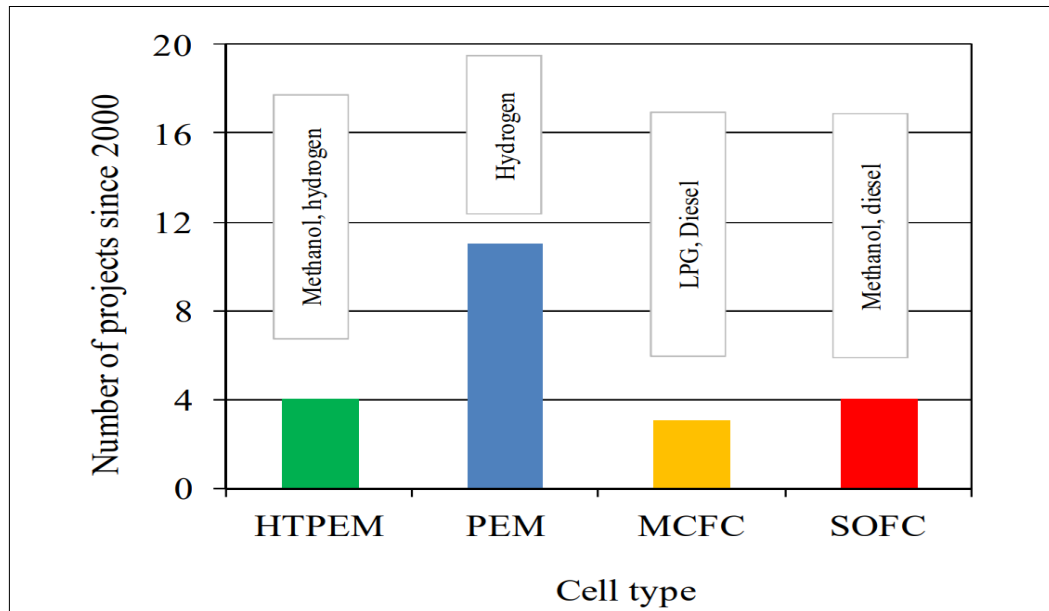

Note. Adapted from *The potential of fuel cells as a drive source of maritime transport* by Markowski, J., & Pielecha, I. (2019). *In IOP Conference Series: Earth and Environmental Science* (Vol. 214, No. 1, p. 012019). IOP Publishing, (<https://doi.org/10.1088/1755-1315/214/1/012019>).

Figure 3 shows the number of surface ship fuel cell projects from 2000 to 2019. Recession may have affected fuel cell development. The early 2000s recession may have affected the lowest trend line graph in developed nations. The late-2000s recession may have caused a second downturn.

Moreover, fuel cells are being incorporated into a variety of future ship designs that are environmentally friendly. In April 2009, NYK released a preliminary exploratory design for the NYK Super Eco Ship 2030. This vessel is anticipated to be significantly more energy-efficient and emit significantly less carbon dioxide than other vessels. It will utilize cutting-edge technologies that are widely available by 2030. It is possible to reduce the amount of power required to propel a ship by decreasing the hull's mass and water resistance. Increasing propulsion power through

the use of fuel cells powered by LNG, solar cells, and wind energy will reduce CO₂ emissions by 69% per container transported (NYK, 2009). Wallenius Wilhelmsen also incorporated a futuristic concept into the design of the E/S Orcelle, a car carrier capable of carrying up to 10,000 vehicles on eight cargo decks. It has a pentameral hull, which eliminates the traditional stern propeller and rudder, thereby eliminating the need for ballast water. During its voyage, the E/S Orcelle will produce zero emissions. It is powered by the intelligent use of energy from renewable sources, such as solar energy, wind energy, and wave energy, and will be used in tandem with a hydrogen-powered fuel cell system. According to Wallenius Wilhelmsen, future technologies will have the capacity to convert solar, wind, and wave energy into hydrogen that can be used immediately or stored on board (Wallenius, 2010).

2.4 Safety issues associated with HFC

Concerns about the safety of fuel cells include the potential for fire, explosion, asphyxia, and electrical shock. The primary focus, however, is on the fire and explosion risks associated with the system's hydrogen content. The mixture of hydrogen and air, a combustible gas, is explosive. In reality, a wide variety of air/hydrogen concentrations can trigger an explosion. Four percent by volume to seventy-five percent by volume of hydrogen can spontaneously ignite. Hydrogen and air mixtures in a confined space pose a significant risk of explosion under these conditions. In addition, the ignition energy necessary to initiate a hydrogen/air explosion is incredibly low, requiring only 0.02 mJ. In the event of a breach, hydrogen quickly dissipates upwards due to its greater buoyancy than air. These characteristics will serve to reduce the likelihood of an explosive atmosphere forming as a result of the leak occurring in a well-ventilated area.

As an aside, a hydrogen leak in an enclosed space containing electrical equipment or other sources of ignition can result in an explosion (Newsholme, 2004). When an ignition source is nearby, high barriers such as ceilings and other impermeable surfaces pose a heightened risk (Newsholme, 2004). Consequently, fuel cell safety can be

ensured by referring to classification organization-developed standards. If fuel cells are not adequately sealed, gas leaks and explosive atmospheres could result in terms of safety.

The fundamental principle of the laws is that, in comparison to conventional machinery, the level of safety cannot be reduced when using gas. In addition to the existing "intrinsically gas safe" system for pipe that contains flammable gas, the "emergency shutdown protected machinery (ESD)" concept has been developed. In most circumstances, emergency shutdown-protected machinery areas are considered gas-safe, but in rare cases they may become gas-hazardous. In such situations, all machinery and ignition sources not protected by explosion protection must automatically shut down (Vogler, 2008).

An additional danger that needs to be taken in consideration is the life-threatening hazard of electricity (Newsholme, 2004). Both the regular 240-volt mains A.C. power source, as well as direct output of the fuel cell stack, poses electrical risks in fuel cell installations. The total output from the stack can be in the range of 200-400 volts and 500 amps, despite the fact that the voltages and currents produced by each element in the stack are extremely modest. A prevalent problem is a lack of management over risky places, such as areas where unprotected bus bars are present (Newsholme, 2004).

Despite the additional risks associated with the use of fuel cells, it appears that this problem can be successfully resolved by adhering to a set of clearly defined and strictly enforced criteria during the design and operation phases.

2.5 Regulatory perspective of HFC use in shipping

It has been highlighted that hydrogen has a high probability of leakage and diffusion. Since it has also a very large spectrum of fuel explosions and powerful explosion energy (Rigas et al.,2012), fire and explosion have to be considered when dealing with hydrogen. Given these facts, working around hydrogen on board has the potential to expose the crew to toxic chemicals, including fire and explosion risks in

case of leaks. However, environmental and safety standards are becoming increasingly vital due to the fact that activities that maintain shipping are highly important to helping supply and demand chains. This is because sustain shipping activities are very important to helping supply and demand chains (Rattazzi et al., 2021).

In terms of regulatory perspective, an initial strategy has been adopted in 2018 by IMO in order to downsize GHG emissions 50% by 2050 compared to 2008 rates (Rattazzi et al., 2021). In 2021, IMO's Subcommittee on Cargoes and Containers (CCC 7) finalized draft guidelines that have been assigned for development of standards specifically for ships using fuel cells (Rattazzi et al., 2021). The guidelines in this draft provide information on fire and gas/vapour detection to prevent fuel cell-related damages. Moreover, The European Maritime Safety Agency (EMSA) has carried out an in-depth technical study on the application of fuel cells in shipping with the purpose of performing a safety assessment. This study also included an analysis of the potential risks posed by this emerging technology (Tronstad, 2017). In light of upcoming environmental restrictions and the further advancement of fuel cell and hydrogen technologies, European Maritime Safety Agency (EMSA) is establishing a specific activity to promote maritime fuel cell projects and hydrogen technology (Tronstad et al., 2017).

As this new type of energy power is considered to have a low flash point, all matters relating to it are governed by the international code of safety for ships using gases or other low-flashpoint fuels (IGF Code) (Tronstad et al., 2017). The IGF Code entered into force in 2017 aiming to reduce the risks which may happen to the ship, to the crew and to the environment. However, this code addresses only concerns arising from the use of liquefied natural gas (LNG). Consequently, the subcommittee established an enhanced work plan for developing safety measures for new low-flashpoint fuels under the IGF Code, which will be consideration by MSC 105 (Tronstad et al., 2017). In this regards, further pre-normative work will be needed to have wider compliance with hydrogen fuel cell use on board ships.

Current regulations ban the use of hydrogen fuel cells as propulsion power. However, classification societies and other players are conducting risk assessments to provide advice and guidance that will contribute to the establishment of new regulations and standards (Ash & Scarbrough, 2019).

2.6 Hydrogen technologies in the maritime industry

Currently, compressed hydrogen is used to demonstrate the viability of hydrogen in the maritime shipping industry. Hydroville is the first seaworthy passenger vessel in the world to be powered by dual-fuel hydrogen combustion engines. She was designed by the Belgian ship owner CMB (CMB, 2020). The shipowner has recently formed a joint venture called BeHydro with the aid of engine manufacturer ABC engines (Garmsiri et al., 2013). This demonstrates, more than anything else, the interest and potential of shipowners in H₂-fueled engines. Ships powered by fuel cells and hydrogen have also been demonstrated, albeit to a lesser extent; the Duffy–Herreshoff water taxi and the Yacht XV are two examples (Garmsiri et al., 2013).

HySeas III project also uses hydrogen-powered ships to ferry people around the Scottish Orkney Islands (Gomez Trillos et al., 2013). The Technical University of Berlin studied hydrogen propulsion for the RiverCell-Elektra towboat. The ZemShip Alsterwasser demonstrated hydrogen as a shipping fuel near Hamburg (Pratt & Klebanoff, 2018). Nemo H₂ in Amsterdam, Hornblower Hybrid and Hydrogenesis in Bristol, MF Vigen173 and SF-Breeze near San Francisco are examples of hydrogen-powered passenger vessels (Pratt & Klebanoff, 2016).

2.6.1 On-board end use

Hydrogen is commonly associated with fuel cells in energy systems, but it can also be burned in diesel and gasoline engines. Hydrogen can be used in these combustion engines as the sole fuel (mono fuel) or as part of a dual fuel system (Dimitriou & Tsujimura, 2017). Some storage methods also require the use of reactors to release the hydrogen before it can be utilized in an engine or fuel cell. The final

product of hydrogen, whether it is burned or used in a fuel cell, is always water. In terms of emissions, the amount of nitrogen oxides (NO_x) that fuel cells emit versus combustion engines is the most significant (Heffel, 2003). Fuel cells have a higher energy efficiency than internal combustion engines, but they are significantly more expensive and typically have a shorter lifespan (Braga et al., 2014). While combustion engines have been used in the maritime industry for decades, fuel cells are still a novelty in the industry today (Ahmadi et al., 2020).

2.6.2 Fuel cells

Hydrogen is the most commonly used fuel source for fuel cells (FCs). As an electrolyser system, fuel cells operate in the opposite direction of this review's emphasis on its particular operations. This means that at the electrodes of the fuel cell, the fuel is broken down into its constituent parts and electricity is generated. To use fuel cells as the primary ship propulsion system, a ship must be electrified, whereas the rotor is currently powered by a mechanical engine. There are many different types of fuel cells, such as proton exchange membrane fuel cells (PEMFC), molten carbonate fuel cells, and solid oxide fuel cells. The PEMFC system is one of the most widely used fuel cells, but it is limited by its need for ultrapure hydrogen and its susceptibility to CO and ammonia poisoning (Lan et Tao, 2014). Systems like molten carbonate fuel cells and solid oxide fuel cells are being studied as they are more poison-resistant at higher temperatures (Sasaki et al., 2006). Additionally, the PEMFC has been improved by employing membranes that can withstand higher temperatures (Verma & Scott, 2010). Due to the high temperatures at which molten carbonate and solid oxide fuel cells operate, they can immediately degrade hydrocarbons and ammonia within the cell (Wojcik et al., 2003). Due to the high temperatures generated by fuel cells, NO_x production can still be a problem (Chuahy & Kokjohn, 2019).

2.6.3 Hazards of on-board use

First, it must be acknowledged that hydrogen has a negative reputation when it comes to safety. The phobia of this molecule can be traced back to the Hindenburg

disaster in 1937; the destruction of this airship instilled in the public a fear of hydrogen use. It is also suggested that the public be better informed about the usage of hydrogen as an alternative to fossil fuels (Pratt & Klebanoff, 2016). The low ignition energy of 0.017 mJ, coupled with hydrogen's wide range of flammability (4–75 vol % in air), results in an easily ignitable fuel. Because hydrogen is a fuel, it must be combustible. It should be noted that small molecules like hydrogen can escape from even the most impermeable pipework or storage containers. In addition to its high diffusivity, this is one of its key advantages. In the open air, hydrogen disperses quickly because it is so light (Saffers & Molkov, 2014). Additionally, there are hydrogen detectors capable of detecting a level of hydrogen 100 times lower than the explosion limit (Xiao et al., 2018). Aside from that, excessive amounts of hydrogen, an odourless, colourless gas, can cause asphyxiation by displacing oxygen in the atmosphere. The discharge of hydrogen in a compressed state must be managed to avoid the risk of explosions. The tanks are built to withstand bullet strikes, therefore the tanks are safe to store in (Paczkowski, 2004). It is necessary to use materials that can resist extremely cold temperatures when storing hydrogen in a cryogenic liquid form, such as liquid hydrogen at 253 degrees Celsius or S-LNG at 162 degrees Celsius. Damage to the ship's hull may result if the cryogenic liquid leaks out of its containers. Because of the liquid's evaporation in the air, larger spills of liquid hydrogen or LNG quickly chill the ground surface. The cold fracture of the steel in the ship's hull can be caused by spills, and this can result in the ship's hull being damaged (Mokhatab et al., 2013). After the release of cryogenic liquids, extremely cold vapour clouds are produced. People working aboard the ship are at risk because of the low temperatures caused by these vapour clouds. Water vapour in cryogenic liquid clouds makes them heavier than air, which prevents them from dispersing like gaseous fuels, which do. As a result, asphyxiation and explosion risks are exacerbated. The Fischer–Tropsch diesels are predicted to provide no new dangers because of their similarity to conventional fuels. The carbon chain molecules in FTS diesels are identical to those found in conventional diesel fuel, despite the fact that recycling CO₂ makes them appear to be a greener fuel. Because of this, oil spills from FTS diesels have a smaller negative impact on the

environment than spills from ordinary crude oil diesels. Contrast this with the biodegradability of methanol, which is very water-soluble and rapidly degrades. As a result, compared to diesel fuel spills, methanol spills from ships have a much smaller environmental impact. When compared to diesel, the boiling point of methanol is 65 degrees Celsius, while the flashpoint is 11 degrees Celsius. Methanol, on the other hand, has a larger chance of catching fire than diesel. The lethal dose for ingesting methanol is on the order of 56.2 grammes per person, while the lethal concentration for inhaling it is between 4000 and 13 000 parts per million (Moon,2017). There will be increased monitoring of methanol levels around ship's engine rooms and fuel tanks to ensure crew safety because methanol evaporates five times faster than water. Long-term exposure to methanol, even at low levels, can cause health problems (Verbruggen, 2015). Because formic acid is a commonly produced chemical, it may be handled and transported with ease. This hydrogen carrier can thus be used as a ship's fuel because tanks and pumps to transfer it are readily available (Apter et al., 1994). It is still a caustic substance that can inflict severe burns to the skin and eyes, however. Despite the fact that it is less prone to evaporate than methanol, formic acid should nevertheless be monitored in enclosed areas on the ship to ensure that the ship's air is not polluted by formic acid.

Under normal atmospheric conditions, ammonia and hydrogen are both invisible, but ammonia has a very strong smell, and the human olfactory sense can detect ammonia at 50 ppm. The ammonium ion (NH_4^+), which is very alkaline and produces burns on animal tissue, notably in the respiratory system and the eyes, is formed when ammonia comes into contact with damp surfaces (Nowatzki, 2008). Large concentrations of ammonia will produce clouds that are heavier and more easily blown by the wind. There can be fatalities even hundreds of metres away from where the ammonia cloud is being inhaled because of the dangerous region that can be covered by it('exposure guideline', 2010). The safety record of DBT is excellent. High boiling and auto-ignition temperatures indicate that only very low fire or explosion risks are associated with this transporter. While DBT and hydrogenated H18-DBT share many of the same chemical properties as diesel, they are predicted to be safer for the

environment and last for a shorter time on a vehicle's fuel tank. As a result, the toxicity of DBT is more difficult to determine because it comprises a variety of regioisomers. It has just three aromatic rings and no excessive branching, according to a set of rules of thumb given by Boethling et al (2007). DBT does not have a high halogenation level, a high number of aromatic rings, or excessive branching. Not only are diesel fuels not environmentally friendly, but this chemical is not biodegradable or biodegradable. The use of hydrogen as a zero-carbon fuel is possible; however, it comes with the same safety issues as fossil fuels that do produce CO₂. There is a difference in the stability of the carriers in the solid-state hydrogen storage systems. Hydrogen carriers should be kept out of the reach of both air and moisture (Cao et al., 2018). According to the MSDS (2020) it is necessary to keep NaBH₄, NaAlH₄, and MgH₂ out of direct contact with water. If this is not the case, the carrier's hydrogen will be released, which could be dangerous if it happens while bunkering or sailing.

In conclusion, numerous efforts have been made by policymakers, stakeholders, and the research community for the use of hydrogen fuel cells in the shipping industry in an effort to fill knowledge gaps regarding hydrogen safety. However, there are currently a number of regulations that do not align with safety-specific requirements for the application of hydrogen fuel cells. Hydrogen poses a significant hazard, so risk assessment methodology appeared to be the most effective means of addressing safety concerns. In this context, additional research is required to evaluate the safety of ships equipped with hydrogen fuel cells, to aid policymakers, and to develop pertinent codes, including the IGF code and related rules.

CHAPTER 3: RESEARCH METHODOLOGY

This study employs a three-phase methodology: HAZID through examination of Hydrogen fuel cells accidents in various industries; and expert interview based on Delphi method to identify the most critical risks and the potential consequences that can result from the use of HFC on board ship. In the end; a proposed safety barriers analysis will be proposed and validated by two of professionals of the World Maritime University (WMU). The flowchart in Figure outlines the hazards and safety measures followed in the research methodology.

Figure 4

Research methodology design (Designed by the Author)

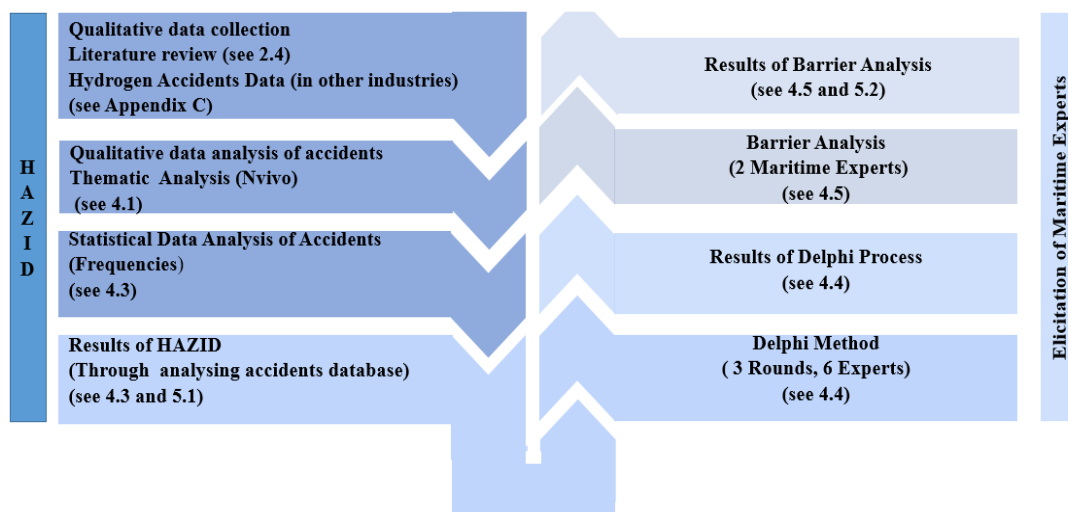

3.1 Accidents database to support risk assessment process

Hydrogen has already been safely used for decades in a variety of industrial application areas, such as aerospace technology, chemical processing including refineries, fertilisers, food and electronic industries, etc. (Wen et al., 2022). Accordingly, hydrogen and fuel cells technologies are expected to play a key role in implementing the transition of the energy systems from fossil-fuel-based to a more

sustainable energy (Linstad et al., 2015). In order to deploy this type of energy on a large scale, the aspect of safety needs to be addressed to ensure at least the same level of safety as the technologies that are currently in use.

With regards to safety research, one of the most methods used in industry to develop and improve safety strategies for a specific technology is the return of experience obtained from its previous deployments (Mirza et al., 2011). As an example, the petrochemical industry is known for learning from past incidents in order to avoid recurrence of similar events and improve overall safety measures (Mirza et al., 2011).

Accident databases are most often developed to provide lesson learned from existing accidents, as a basis for improving technical systems, operations, management systems, and organizations (Mirza et al., 2011). Accidents data base maybe useful sources of ideas for identifying what are going wrong when we are doing a risk analysis (Mirza et al., 2011). According to Kvaloy and Aven (2005), data from accident can be used to identify hazards which may give an input to risk analysis. Many databases with information about accidents and incidents have been established. Some of these data bases are listed below in Table 2.

Table 2

Hydrogen accident data bases

Database Name	Number of incidents	Web address	Administratered by
HIRD	194	http://www.h2incidents.org/	Pacific Northwest National Laboratory,USA.
HIAD	253	https://odin.jrc.ec.europa.eu/hiad/globalview.hiad	European Commission Joint Research Center (JRC),Petten,Netherlands.

ACUsafe	No information available	Htpps://www.acusafe.com/Incidents/frame-incident.htm	US Chemical Safety board, USA.
eMARS	743	http://mahb-srv.jrc.it/typo3/?id=4	Major Accident Hazards Bureau, JRC (EG), Italy.
FACTS	24,100	http://www.factdoline.nl/	TNO Industrial and External Safety Departement, Netherlands.
ERNS	No information available	Http://www.rtknet.org/d/b/erns/sustance	OMB Watch (A non-profit organisation),USA.
ARIA	37,000	http://www.aria.developpement-durable.gov.fr/barpi_stat_s.gnc	Frensh Ministry of Ecology and Sustainable Development,France.
ARIP	4946	http://www.epa.gov/oem/tools.htm#arip	Environmental Proctection Agency,USA.

Note. Adapted from *Analysis of hydrogen incidents to support risk assessment*, by Mirza, N. R., Degenkolbe, S., & Witt, W. (2011), *International journal of hydrogen energy*, 36(18), 12068-12077,(<https://doi.org/10.1016/j.ijhydene.2011.06.080>).

The information that is gleaned through accident reviews and investigations assists industries in developing a more effective safety level system, which in turn assures a more secure and healthy working environment in their respective environments (Kavloy and Aven, 2005). This method is still beneficial, as it reveals in what direction the on-going research efforts should be focused, and it does so in an informative manner. This type of information obtained from the investigation of occurrences can also be used to bolster some aspects of the risk assessment process (Mirza et al., 2011).

As mentioned previously mentioned, there are a number of databases that store information about accidents that have occurred in the past. These databases each have their own set of benefits and drawbacks; for example, some of them are not free to use or require some kind of subscription, and other databases contain information that is not reliable (Tauseef et al., 2011). In addition, according to Arun et al (2022), among accident databases, eMARS–The Major Accident Reporting System gives the most

comprehensive information possible. This is due to the fact that member states are required to record all incidents in this accident database. A full report from this database, however, takes at least two to three years to become available following the investigation. Given this fact, in this study from 2005 to 2020 Hydrogen accidents in other industries were examined in eMARS database. This indicates that the most recent adjustment to the update has been taken into account.

As a part of this study, drawing data from previous accident involving Hydrogen in various industries, a Hazard Identification (HAZID) analysis is performed to determine the potential safety threats and their causes and consequences that may occur on board ships. As a result of the scarcity of data from the maritime sector, the identification of hazards process can be conducted through the examination of hydrogen accidents in other industries.

As a result of the scarcity of data from the maritime sector, the HAZID will be conducted by examining hydrogen accidents in other industries following by the expert panel judgment to validate the outcomes.

3.2 Data Analysis of Hydrogen incidents from eMARS Database

For the purpose of this study an exploratory Hazard identification study has been designed on past learning and experiences in various industries. The HAZID study was structured to identify the potential hazards associated with the use of hydrogen fuel cells. Following a systematic review of the related literature, Hydrogen accidents in other industry were examined in Major Accident Reporting System (eMARS) database. As a result, data of 140 accidents from 2005 to 2020 were collected accordingly. The data, consisting of accidents report summaries were then sorted for the analysis in an excel file in five columns: event type, industry type, accident causes, accident consequences and lessons learned. A table has been attached at the end of the research as Appendix C. The file was then imported as an internal material to the qualitative data analysis software, NVivo 12. Subsequently, thematic and statistical analyses of the data were performed.

3.3 Thematic analysis (TA)

According to Braun and Clarke (2012), TA is a method for systematically identifying, organizing, and gaining insight into the factors that are significant across multiple data sets. The objective of this technique is to determine what is shared by the most popular topics in the database to be analysed. The TA can be used in a variety of situations and coding and categorizing of data into themes is one of those opportunities (Huberman & Miles, 1994).

When analysing data qualitatively, it is crucial to find relationships between categories and themes of data to gain a deeper understanding of the phenomena involved. Data was previously sorted, clipped, and categorised using coloured pens, a procedure that took a long time (Hilal & Alabri, 2013). Recent developments in the field of software tools for qualitative data analysis have greatly simplified and reduced the difficulty of this once-intensely complex process (Dhakal, 2022). Given this fact, Nvivo as the qualitative data analysis software is considered the best tool in this research to manage the coding procedure.

3.4 Barrier Analysis approach for accident prevention

The Management Oversight and Risk Tree (MORT) is an analytical procedure for determining causes and contributing factors (Johnson, 1975). At the first time MORT originated from a project undertaken in the 1970s. The purpose of its creation aimed to provide the U.S. Nuclear industry with a risk management program competent to achieve high standards of health and safety. Barrier analysis is a component of MORT analysis, a complex approach to accident investigations. It has been found that every single accident tends to be complex in terms of many casual factors and preventive measures. This makes it essential for investigator to have a methodology for breaking down possible sequence of events and controlling factors leading to an accident. According to the concept of The MORT model, it illustrates that the causes of any accidents can be grouped into four main categories (Kingston et al., 2002). Using this categorisation, can be a relevant step for analysing accident data bases.

3.5 Delphi methodology

During the following steps of the research methodology of this study, a variety of sources of information were consulted in order to collect and evaluate the data that will be the subject of this chapter. In contrast to the majority of experimental studies conducted in the field of maritime engineering, the method that was applied during this study was not heavily based in engineering, physics, or mathematics. Instead, it was heavily based in human behaviour, thought process, and opinion that was informed by individual experience. Despite its uniqueness, the methodology has been validated over the course of time and is widely accepted both in academic circles and in the field of maritime research. The reasons for selecting the method, the steps involved in the method, as well as the limitation of employing the method, will be discussed. The last part of this chapter will be a discussion of how the research was conceived of and carried out within the context of this study.

Every aspect of the risk assessment process contains an element of uncertainty, which is frequently exacerbated in the case of developing technology (Beaudrie et al., 2016). In the lack of sufficient empirical evidence, it is possible to estimate unknown parameters and models based on the subjective expert judgement elicited through thorough elicitation techniques. One of the most used methods in technology forecasting is the Delphi method (Helmer et al., 1966).

As with many other technologies and techniques developed in the 20th century, the Delphi method is a structured research technique used to support a variety of risk assessment studies in the maritime domain that has applications in other fields (Helmer et al., 1966). In 2008, Zaloom et al. asked participants from five sectors of the maritime domain: public ports, United States Coast Guard (USCG), shipping industry, private ports, and law enforcement to identify events that could disrupt shipping and to rank their likelihood of occurrence on the Sabine Neches Waterway. The results indicate that a panel of experts was able to reach a high level of consensus regarding the types of events posing risks to shipping and the likelihood of their occurrence. Moreover,

according to Streveler & alstatement (2008) "Proponents of the Delphi method recognize human judgment as a legitimate and useful input in generating forecasts and therefore believe that the use of carefully selected experts can produce reliable and valid results." In other words, it is believed that selecting an appropriate panel of experts will increase the validity of the findings because, if a diverse panel reaches a consensus, it will bolster the value of the findings.

Goerlandt et al. (2017) stated that the Delphi method is a suitable method for detecting maritime risk trends, based on the tools that can detect and assess the significance of new and emerging risks in the maritime transportation system, such as the use of a new type of fuel or a new technological system such as an unmanned vessel. Valdengo et al. (2018) conducted a Delphi survey to identify training and technology gaps/needs for maritime Special Operations Force (SOF) personnel, which led to the provision of training and technology to assist SOF personnel in performing their missions in maritime surveillance more effectively. Moreover, in exploratory, theory-building research activities involving complex, multidisciplinary issues, the Delphi method is said to be particularly applicable, particularly when the focus of the research is the examination of new future trends (Meredith et al., 1989).

In addition to the literature review, the analysis of previous accidents involving Hydrogen and fuel cells to support the risk assessment of hydrogen fuel cell in ship has revealed a knowledge gap in the application of hydrogen fuel cells in the maritime industry. Due to the paucity of research in this field and the complexity of the research topic, Delphi is seemed to be the ideal research technique for this study. The organised group communications approach of the Delphi method promotes individual ideas and progressive group solution creation (Gupta & Clarke, 1996). In addition, the selection of participants from a variety of disciplines and backgrounds for the Delphi panel enables the study to adopt a more focused approach in attempting to identify the most critical risks and safety measures on board an HFC ship, by leveraging the experts' depth of knowledge in hydrogen use and fuel cell technology and their area of expertise.

3.6 Research design

3.6.1 Data collection

Multiple sources of evidence methodology contribute to internal validity, according to Yin (2003), because it offers data from a variety of sources to assess and discuss the study topics. As a result, the validity of this research was ensured throughout the data collection procedure by using multiple sources of evidence. According to the presented research, the options for the investigation were deemed to be documents, analysis of incidents database, Delphi interviews and semi structured interviews. Some kinds of evidence, including observation or survey, were unsuitable for the study due to the constrained timeline and research site. Even though not all of the sources were ready, every possible source was thoroughly investigated to ensure that we had sufficient data to analyse and that we could provide an effective response to the research topic.

Figure 5

Multiple sources of evidence

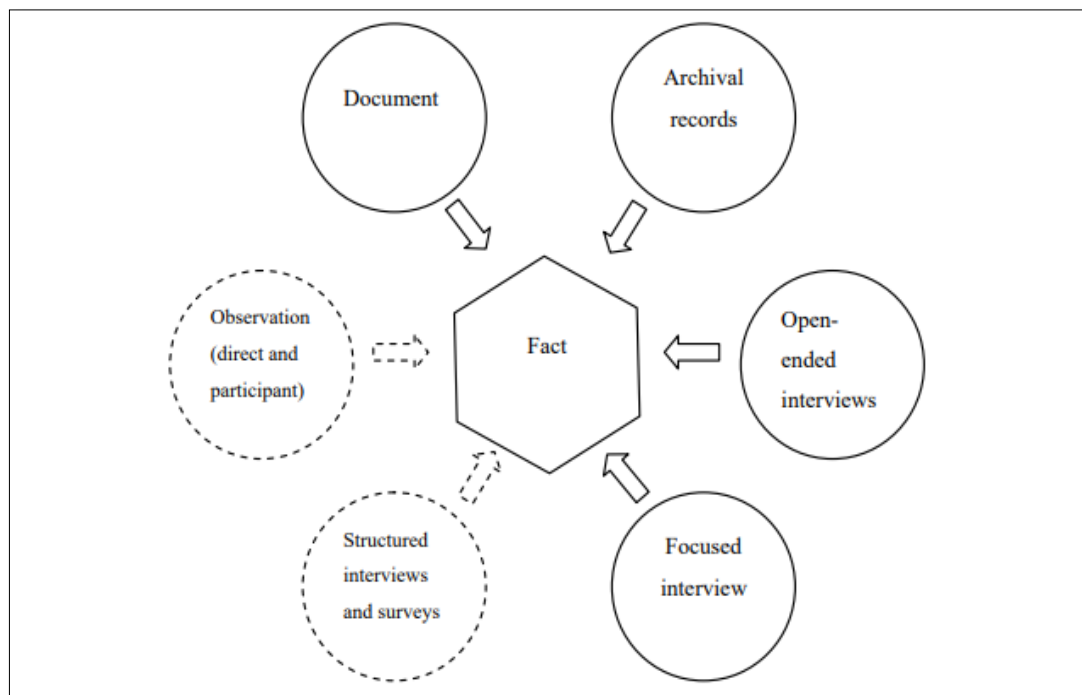

Note. Adapted from *Design and methods (3rd ed.)*, by Yin, R. K. (2003), *Case study research: Thousand Oaks, CA: Sage*, (<https://doi.org/10.1037/13620-009>).

3.6.2 Interviews

In order to research the study, interviews were conducted with individuals who had experience or understanding regarding the HFC technology. The purpose of these interviews was to gather information for the investigation. The style of interview that we decided to use for this investigation is called a semi-structured interview. The topics that were going to be discussed and the questions that were going to be asked were prepared in advance, but they were flexible enough to be adjusted to better fit the flow of the conversations. The questions were of an open-ended nature, which will help in gaining a better understanding of the respondents' experiences. The questions and interview guide will provide a direction for the dialogue during the interview so that it will focus on the evaluation of risks and the integration of the system. At the same time, we were able to obtain more supplementary data or topics from interviewees beyond the scope of our interview questions. According to what Oates (2005) states about the framework of the semi-interview, extra questions might be asked whenever the respondents suddenly brought up new issues or fascinating themes. During the interviewing research phase, a framework for semi-structured interviews was utilised so that various forms of information that we might obtain could be captured.

Emails were sent to experts to introduce our research and obtain contact information for the person we can interview. Many marine organisations and shipping firms provided encouraging responses when asked if they might contribute their valuable time to the project. E-mails were addressed to the appropriate parties to provide more information about the study and the type of data required. Prior to the actual interviews, they were sent a list of questions to give them time to consider their responses and to allow them to schedule the interview at their convenience. Online meetings were appropriate and sufficiently effective for conducting the interview with them. It is comprised of seven interviews with individuals who have utilised hydrogen

and fuel cells in business and shipping. The respondents are from a variety of industries and positions, which provided a variety of insights on HFCs and risk assessment. During the interview, the interview was recorded by a recorder and also scripted. Each interview began with a summary of the research history and field of inquiry.

After conducting interviews, the experience of the interviewees regarding the application of HFC in the maritime industry was recorded. Capturing and further investigating or analysing the most significant risks and associated repercussions to better help the risk assessment process.

3.6.3 Application of the Delphi method on the data collection

The purpose of the Delphi study is to elicit from Delphi experts a convergent list of significant risks and hazards associated with HFC-powered ships in order to facilitate risk analysis and decision-making. The ultimate research conclusion is qualitative, but the responses must be quantitative so they can be statistically analysed for the Delphi technique to be successful. To accomplish this, the interview questions required the experts to assess the importance of the output's relevance. The data gathering consists of two major steps: the selection of experts and the rounds of the Delphi questionnaire.

3.6.4 Expert selection

The selection of qualified experts is the primary determinant of the quality of any Delphi study. According to the procedure outlined in Okoli (2004), the experts will be chosen accordingly.

1. Prepare a Knowledge Resource Nomination Worksheet (KRNW).

The KRNW intends to categorise the experts so that no significant categories of experts are neglected. As this research focuses on HFC technology in the maritime industry, the specialist categories include chief engineers, Masters, BV inspectors, and personnel in charge of the machinery and safety of Plan Approval surveyors.

2. **Populate the KRNW with Names.** Under the various categories, possible experts were selected. The experts comprised of six maritime professionals. Two experts will be invited per category for the interview process, for a total of six experts. This guarantees that each category is well represented while keeping the number of participants manageable. The Delphi method does not require a big number of participants because it is a targeted research technique designed to achieve a decent consensus of viewpoints among a group of professionals.
3. **Invite Experts.** The experts were reached by email, phone, and online meeting. In addition, the initial strategy included briefing the experts on the research study and the Delphi procedure.

3.6.5 Delphi interview questions rounds

The Delphi study was conducted in three iterations, as described below: (most hazardous spaces based on the literature review).

Round 1. Brainstorming of hazard identification. In this stage, the experts were tasked with identifying and ranking the most pertinent places for the concept installation based on the ship system and interview questions. In addition, they were asked to identify any other locations on board ships that they consider to be hazardous. At this stage, the experts were not briefed on the results of the literature research or the data obtained from lessons learned past hydrogen events. The first questionnaires were created with an introduction that provides a brief summary of the research topic, the Delphi method, and the participation requirements. The goal of the preamble was to provide sufficient information to the experts to prevent uncertainty on the research topic and to provide the experts the best opportunity to provide high-quality responses for the subsequent questionnaire round.

Round 2. After analysing the outcomes of the first round, the second questionnaire conveyed the findings of the first round to the experts. The experts were also tasked with identifying all potential dangers and their

underlying causes; for each prospective hazard, the probability of its occurrence and potential repercussions were debated and ranked. Any newly detected possible dangers in the first round were relayed to the expert panel and incorporated into the ranking.

Round 3. Identification of the severity of the consequences. The second round's results were relayed to the experts. When an expert's round 2 ranking was significantly different from the group mean ranking, the experts were asked to explain why. Accordingly, the experts were asked to discuss the severity of the prospective implications.

3.6.6 Expert judgment

According to Stoneburner (2002) the likelihood and severity of a result are both important considerations for determining a risk level. After a list of potential hazards and their repercussions has been compiled, it's time to determine the likelihood of an incident and the extent of any damage that could result.

In this study, the evaluation of risks will be done by expert judgment because in this method it is easy to use providing there are clear guidelines on how to evaluate the level of risk. Other methods are more complex and require more detailed calculations. In order to prevent accidents and other unwanted events possibly occurring when dealing with installations such as HFC on board ships this requires evaluation of identified risks.

- **Selection of Probability Occurrence Method**

Safe practices in the use of hydrogen and fuel cells are essential for the widespread acceptance throughout the maritime industry. In this scenario, to identify and explore potential undesired events a risk assessment is necessary. However, in many cases, this approach is not possible due to unavailable or non-representative data. Many researches have done previously that relied on expert opinion to assess the probability of occurrence of undesired events

particularly when data are unavailable or if it is about a new technology or no accidents have been occurred yet . As stated by Martins et al. (2020), the probability evaluation of events based on historical data may not be accurate and should be elicited from experts. Expert elicitation is deployed when data are absent or uninformative and critical decisions must be made (Martins et al., 2020).

It's worth noting that since the introduction of HFC as a power to propel ships, the marine industry has experienced zero accidents. Thus, a subjective evaluation is a possibility since it permits working independently of the previous data, resulting in more trustworthy outcomes.

- **Severity of consequence based on expert elicitation**

For each identified causes and following hazards, an estimation of potential consequence shall be made; the severity of consequence can be measured as indicated in Table 4. In this context the risk analysis expert can estimate the potential consequences by using their judgement.

All identified hazards are ranked based on their frequency and severity, and then the researcher chooses several main hazards with high risk to analyse in detail. Based on IMO formal safety assessment (2013), the scale used to estimate the probability occurrence of the event as well as the severity consequence scale are presented in the Table 3 and Table 4 as follow:

Table 3

Scale for estimation probability of occurrence

	1	2	3	4
Frequency of the event	Extremely remote	Remote	Reasonably probable	frequent

Table 4

Scale used to estimate the severity of consequence

	1	2	3	4
Severity of consequence	Minor	significant	severe	Catastrophic

3.6.7 Degree of agreement between experts' concordance

In the HAZID process, experts are asked to assign a risk ranking to various events or incidents based on their assessment of their severity and likelihood. Since this is a subjective ranking, it is possible that different experts will come up with different lists of worst-case scenarios. To improve the transparency in the outcome, the final ranking should also include a concordance coefficient showing how well the experts agreed among themselves. In each round, the statistical data (rankings) will be analysed in order to calculate the mean rank and sample standard deviation. The convergence of opinions was qualitatively assessed using Kendall's coefficient of convergence W in accordance with Okoli's Delphi approach (2004). W ranges from 0 to 1, denoting a lack of consensus to absolute agreement, respectively. Schmidt (1997) suggested that a moderate consensus exists for $W = 0.5$ and a strong consensus exists for $W > 0.7$. To conclude the Delphi rounds for the purposes of this study, “ W ” must exceed 0.70.

3.7 Reliability and validity

The exploratory method used in this research provided deep insights and information regarding the aim and the objectives of the research. According to the present study, the past accidents analysis reported by incident database have been performed from 2005 to 2020. In this database, the majority of accidents that occurred in EU member states are listed as well as detailed reports.

The interview questions conducted through the Delphi Rounds were prepared carefully concerning both content and structure and were validated by a professor with extensive experience and knowledge in the maritime sector. The reliance upon expert judgement is recognised as prime input to decision analysis which is a major decision aiding technique (Martins et al., 2020). The reliability and validity evaluation of the Delphi questionnaire was performed in the data analysis. Also, by involving relevant experts for this research such as classification society inspectors, chief engineers, Masters, and Plan Approval surveyors' machinery and safety, a valid and reliable research outcome can be achieved.

3.8 Ethical Consideration

Throughout the research process, ethical considerations were taken into account as an essential factor in order to prevent any ethical issues from arising. The WMU Research Ethics Committee conducted a comprehensive review to ensure that the highest ethical standards were adhered to before approving the interview. In addition to respecting the participants' rights and privacy, the study addressed confidentiality, anonymity, data protection, and withdrawal options. Importantly, the individuals' participation was entirely voluntary and they were not compensated for their involvement. After the dissertation was submitted, no changes or additions were made to the received data, and all materials were removed. The protocol of the WMU Research Ethics Committee is included in Appendix A: WMU Research Ethics Committee Protocol.

CHAPTER 4: DATA ANALYSIS

A theoretical basis for the study as well as recommendations for conducting the research was presented in previous chapters. The following section provides an overview of what are the lessons learned from analysing the data. In this context, analysis of qualitative data based on accident database is presented first and then proceeds on to consideration of the expert judgment data analysis.

4.1 Thematic analysis

Thematic analysis was performed to identify categories and themes, which would capture the causes and consequences of the examined accidents.

4.2 Management Oversight and Risk Tree

Using the Management Oversight and Risk Tree (MORT) method, the detected direct causes of hydrogen-related incidents were classified into four main groups (Kingston et al., 2002) and based on the accident analysis, further segmented into 17 categories (see Table 5). Human factors include errors and violations that contributed either directly or indirectly to accident occurrence. Management factors relate to the organization, that contributed to accident occurrence. Technical factors relate to equipment failure. External factors are associated with the external environment.

Table 5

Classification of accidents causes

Contributing Factors	Themes
Human Error	HE1. Maintenance leading to damage
	HE2. Operations induced damage
	HE3. Changing in operating procedures
	HE4. Inadequate communication
	HE5. Lack of supervision/inadequate inspection

	HE6. Inadequate preventive maintenance
Equipment failure	EF1. Mechanical component failure (pump, valve, relieve valve and piping)
	EF2. Absence of preventive measures (relief valve, sensor...)
	EF3. Design flaw/material incompatibility
	EF4. Installation power loss
	EF5. Inadequate system monitoring/oversight
Management factors	MF1. Inadequate preventive maintenance
	MF2. Training issues
	MF3. Failure in procedures
Other factors	OF1. Operating environment (weather, vibration...)
	OF2. External hazards (external fire, sabotage...etc.)

Regarding the accident consequences, five themes were identified: workers' exposure to hydrogen; fire; explosion; fire and explosion; property damage.

4.3 Statistical analysis

After extracting and classifying the themes, the accident data (causes and consequences) were coded using NVivo. Figure 5 summarizes the statistical analysis of the causes of the accidents. Then, the frequency distribution of accident consequences is presented at Figure 6. In addition, as part of Figure 7, hazards analysis regarding the use of hydrogen in various industries are also displayed.

Figure 6

Frequency distribution of the causal factors of hydrogen accidents in the industry (N=158)

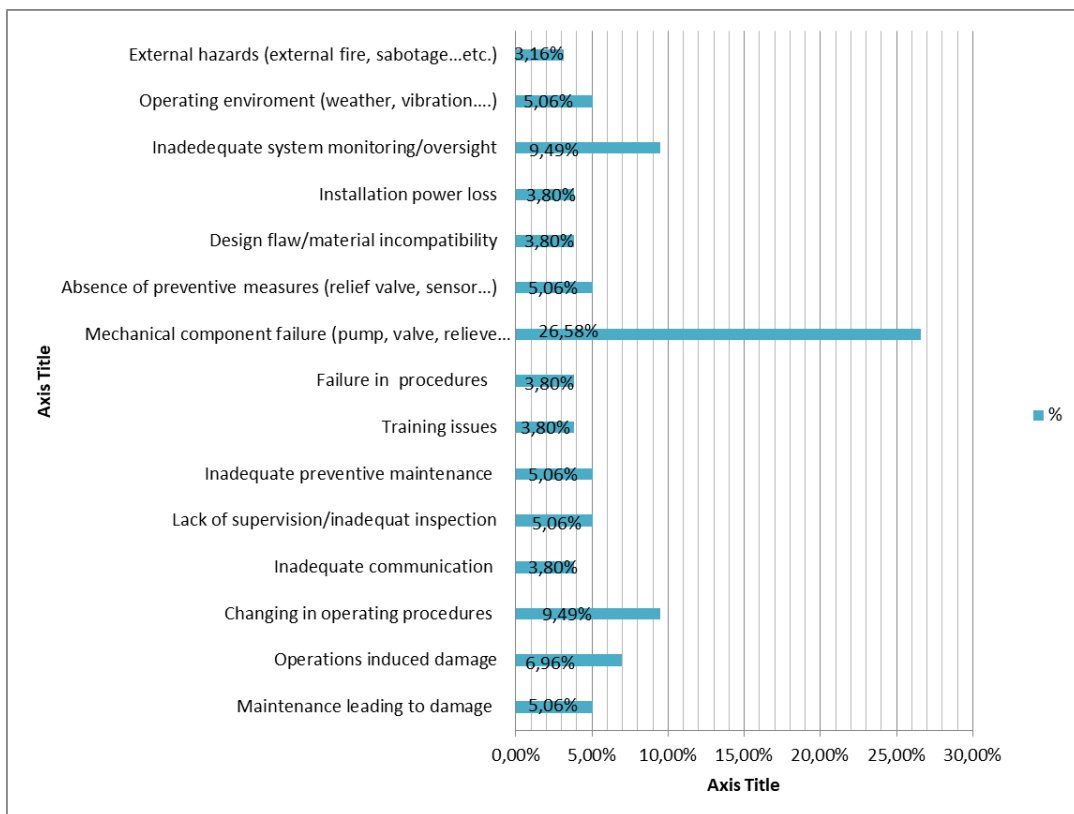

Figure 7

Frequency distribution of consequences of hydrogen accidents in the industry (N=103)

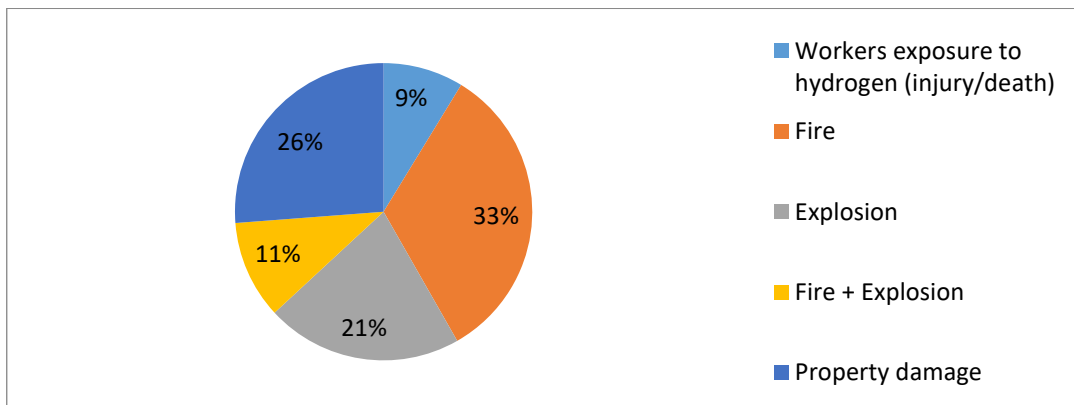
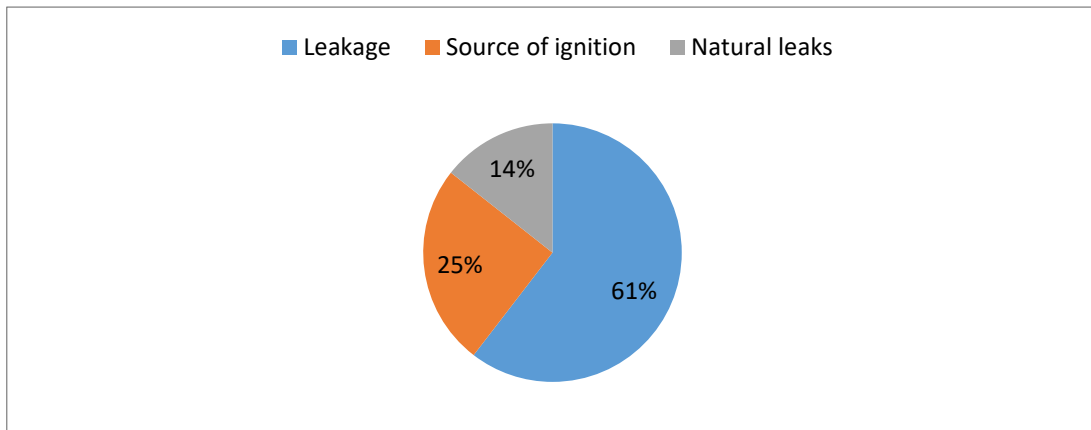

Figure 8

Hazards associated with the use of Hydrogen in the industry (data analysis of 140 accidents on eMARS database)



4.4 Data analysis through Delphi study

Initial invitations and Participant Consent Forms were emailed to prospective Delphi participants. In accordance with the requirements of the WMU Research Ethics Committee, the Delphi study did not begin until all participants had submitted signed consent forms. Six of the ten invited participants consented to participate in this study.

4.4.1 Delphi round 1

Round 1 Delphi commenced in August 2022 with a sample set of six participants. All six participants returned their questionnaires on time. The samples set consist of senior professionals in the maritime industry, which includes BV inspectors, Plan Approval surveyor machinery and safety, Masters, Chief engineers.

Figure 9

Occupation of Delphi participants

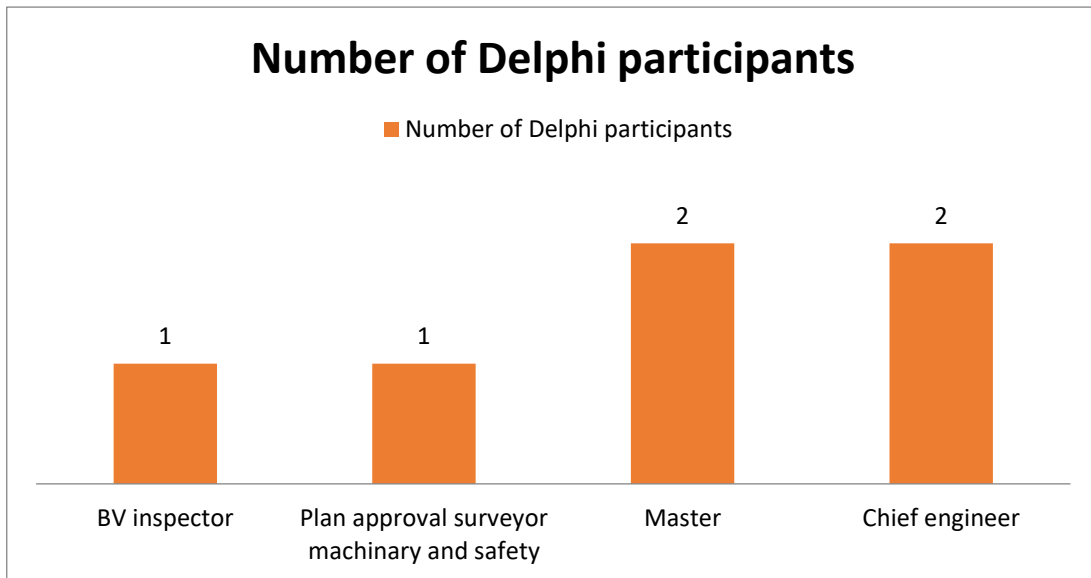

All participants are based in Algeria and France. The participants' ages vary from 51 to 60, indicating the extensive experience they have in the industry. Despite the relatively small sample size, the Delphi panel is a fair representation of the Hydrogen fuel cell technology. In order to safeguard the anonymity of the Delphi participants, subsequent conversations on the Delphi study will be conducted anonymously.

All participants have had involvement with Risk assessment, ship fire and safety in their careers. 90% of participants have had more than 15 years involvement with shipping activities. The majority of participants have an important level of understanding with regards to the use of the hydrogen fuel cell technology.

The first Delphi round asked the participants to analyse the basic installation of ship to determine any spaces that they judge them to be the most risky or dangerous spaces. The first-round questionnaire is shown in Appendix D, and then the feedback results of the expert panel are shown in the Table 6.

Table 6*Feedback results of the expert questionnaire (round one)*

	P1/ RANK	P2/ RANK	P3/ RANK	P4/ RANK	P5/ RANK	P6/ RANK
DS1.Hydrogen tank space	1	1	1	1	2	1
DS2.Fuel cell space	2	2	2	1	2	2
DS3.Engine space	6	6	6	5	5	5
DS4.Battery space	4	4	3	2	1	3
DS5.Bunkering station	3	3	4	1	2	4
DS6.Fuel transfer space	5	5	5	6	6	6

The panel expert has identified six spaces that they judge them to be risky spaces on board HFC ships. These identified spaces are: fuel transfer space, bunkering station, fuel cell space, machinery space, battery space and hydrogen storage space. A number of potential hazards have been discussed, and the two most pertinent ship installation spaces, respectively "Hydrogen storage space" and "Fuel Cell space", have been emphasized.

4.4.2 Delphi round 2

In Round 2, Delphi participants were only presented with the two spaces they believe are most likely to be affected by the risks. Based on this, after identifying risk factors and their causes, the participants were requested to rank their probability of occurrence (PO) and the severity of consequences (SOC). The experts questionnaire is shown in Appendix E. Then the feedback is presented below.

Table 7*Feedback results of the expert questionnaire (round two)*

Hazardous event	Cause	Probability of event (1-4),including all possible causes
Leakage	<ul style="list-style-type: none"> -Pipelines and connections (mainly the connections of the H2 pipe to the FC); Human error (e.g. from maintenance and operation); Corrosion of hydrogen pipes (fatigue corrosion, corrosion thinning, mechanical stress; -Manufacturing errors of fuel cell/ connectors; -Material compatibility with hydrogen (embrittlement); -FC not in conformity for a maritime environment (corrosion, vibration). - Tank overfilling. - Tank materials defect. - Valve leakage. - Defect in piping. - Relief valve failure. - Control system failure. 	4
Presence of ignition source in space	<ul style="list-style-type: none"> -Electrical ignition source: cable going through the spaces, lights, ventilation, fans control valves, detection system, power tools, and equipment during service/maintenance, fc and its associated electrical equipment. -Collision/mechanical damage. -Mechanically caused spark: failure of mechanical ventilation systems fan. -Static discharge. -Heat: heat spread from a fire in adjacent space, friction of machinery or power tools, hot surfaces (overheating, electricity, piping). 	3
Permeation	No particular cause it does happen naturally	1
Flooding	<ul style="list-style-type: none"> -Collision. -External damage. -Hatches that have lost their water tightness. 	2

The PO (frequency) of the hazards and the SOC of the hazards rankings in round two are shown in the table below. For the purpose of statistical computation, let i be the PO, $r_{i,j}$ be the rank given to PO i by participant number j . Let m be the number of participants and n be the total number of PO's.

Table 8

PO of the hazard Rankings $r_{i,j}$ in Delphi round 2 ($m=6$)

Hazards i	Judge j					
	1	2	3	4	5	6
Permeation	4	2	2	2	3	2
Leakage	4	4	4	4	3	4
Source of Ignition	3	4	3	3	4	3
Flooding	3	2	4	4	2	3

Kendall's coefficient of concordance W is used to measure the convergence of ranks.

$$W = \frac{12 S}{m^2(n^3-n)}$$

Where m and n are defined above and S is the sum of squared deviations, defined as follows.

$$S = \sum_{i=1}^n (R_i - \bar{R})^2$$

R_i is the total rank given to PO of the hazard i , and R is the mean of these total ranks.

$$R_i = \sum_{j=1}^m r_{i,j}; \bar{R} = \frac{1}{2} m(n+1)$$

The calculations for “ W ” is shown on Table 9.

Table 9*Calculation the Kendall's coefficient of concordance W (round 2)*

Hazard i	R _i	(R _i - \bar{R}) ²
1	15	0
2	23	64
3	20	25
4	18	9
Total S		162

$$W = \frac{12 \times 162}{6^2(4^3 - 4)} = 0,9$$

With regard to the calculations made in this round 2, a strong consensus has been achieved with $w = 0,9$. The experts generally agreed that leakage is a hazard that is frequent to occur, having a mean rank of 3,83. Presence of source of ignition hazard (3) came second with a mean rank of 3,33 followed by flooding hazard. According to the mean rank in round 2, the PO hazards group rankings are summarised in the table below.

Table 10*Group Ranking of PO in round 2*

Number	Probability occurrence of hazard	Rank
(1)	Permeation	1
(2)	Leakage	4
(3)	Source of ignition	3
(4)	flooding	2

4.4.3 Delphi Round 3

The round 3 questionnaire began with a review of Round two results. Following the recommendations of Schmidt (1997), three pieces of information were fed back to the participants. First, the group mean for probability occurrence for each hazard was given and compared with the participants' Round 2 rankings. As such the

questionnaires were individually tailored to suit each participant's rankings. Second, the degree of convergence of Round 2 opinions was reported as being very strong. Third, for each identified hazard, the percentage of participants who ranked them in the top half was reported. The second and third pieces of information gave the participants a sense of the level of consensus achieved. After that, the participants were asked only about the top hazard which is hydrogen leakage. After that, the expert panel participants were brainstormed and discussed the resulting scenarios from hydrogen fuel leakage in ships. The resulting consequence that was constructed included: crew exposure to hydrogen, fire, jet flame, and explosion. Similar to the round 2, the severity of consequence is shown in Table 11 below:

Table 11

Severity of consequence Rankings $r_{i,j}$ in Delphi round 3 ($m=6$)

Consequences	Judge j					
	1	2	3	4	5	6
Crew exposure to hydrogen	1	1	2	2	1	2
Fire	3	4	3	4	4	4
Jet flame	2	1	1	3	3	3
Explosion	4	4	3	3	3	3

Table 12

Calculation the Kendall's coefficient of concordance W (Round 3)

Consequence i	R_i	$(R_i - \bar{R})^2$
Crew exposure to hydrogen	9	36
Explosion	20	25
Jet flame	13	4

Fire	22	49
Total S		114

$$w = \frac{12 \times 114}{6^2(4^3 - 4)} = 0,63$$

As shown in the table above, a moderate to a strong convergence has been achieved with $W = 0,63$. The experts generally agreed that fire is the high consequence that likely to occur when HFC is installed on board ship, which has a mean rank of 3,66. In second position, the explosion with mean rank of 3,33. Table 12 provides a summary of the consequence group rankings according to the third round's mean ranks.

Table 13

Consequence group rankings according to the third round's mean ranks

Number	Consequences	Rank
(1)	Crew exposure to hydrogen	1
(2)	Explosion	3
(3)	Jet flame	2
(4)	Fire	4

4.5 Barrier Analysis

After consulting with two professionals from the World Maritime University (WMU), the researcher compiled a list of potential safety solutions to mitigate the risks posed by hydrogen leakage, which were subsequently validated by the professionals consulted. (see Appendix B: Personal interview).

The proposed safety measures are listed below:

- Suitable gas detection systems for fire extinguishing and fire detection should be in compliance with maritime environment.

- Ventilation system should be designed to manage the expected natural leaks of hydrogen.
- Protective equipment to reduce the risk of asphyxia to the crew.
- New training for seafarers.
- The use of adequate material in accordance with maritime conditions.
- A regular check of the automatic devices response time.
- Open air system is proposed to ensure an optimal dispersion and a reduced pressure in the spaces.

CHAPTER 5: DISCUSSION AND LIMITATION

This chapter provides a discussion of the findings and its limitation points.

5.1 Discussion of the findings

As previously mentioned, the study included forth research questions.

Research question one (Q1): What are the risks associated with the future operation of Hydrogen Fuel-cell powered ships.

To answer this question Q1, data analysis from land based accidents data were conducted. Content analysis of the Hydrogen accidents database yielded a classification of the contributing factors associated with the use of HFC on various industries in four main categories: human error, equipment failure, management factors and other factors (see chapter 4.2).

Supported by statistical analysis and based on the details of accidents analysis themes, causes and consequences were coded by using Nvivo tool. The themes represented “the nodes”, and each accident meant one “case”. The total occurrence frequency of the direct causes was 158. Equipment failure (48, 73%) and human error (30, 38%) had the highest frequencies. For the human errors, human errors during maintenance (HE1) and operations (HE2) had a total frequency of 19%, while changing in operation procedures (HE3) and inadequate communication had 21%. Management factors represents 20%, in which inadequate preventive maintenance planning (MF1) represents 8%. In parallel, the total frequency of accidents consequences was 103. The analysis of this carefully 140 accidents hydrogen based incidents showed that 33, 01% of them resulted in fires, 21, 36% in explosion and 10,68% in both fire and explosion. Worker’s exposure represented 8, 74% of the total and the reminder percentage were attributed to the property damage.

Subsequently, to qualitatively answer the research question Q2 which is “What is the perception of maritime professionals regarding the risks that might be linked to the

use of HFC on board ships”, Delphi interviews were conducted. The result shows that all the risks associated with the use of HFC in other industries were highly correlated with those that may occur on board ships. With regards to the hazardous events, the group rankings correlate well with the findings of data analysis of hydrogen incidents database in figure 6, for instance the top ranking is leakage has been consistently identified previously in the accident database analysis. Likewise, the source of ignition hazard, which was ranked three by the group, has been identified in 25% of the eMARS Database. However, flooding hazard that can be originated from external damage to the ship (rank 2) was not presented in the eMARS accidents database. This could be explained by the fact that most of the accidents have been occurred basically on other type of industries then in shipping. In practice, flooding hazard should be taken into consideration, as the Delphi participants observed in their experience.

For the leakage hazard, the group rankings correlate well with the eMARS database findings. For instance, the top-ranking fire consequence has been consistently identified in the eMARS database with percentage of 33 % of all analysed accidents. Likewise, the explosion which has ranked 3 by the group has been identified in 21% of the accidents that have happened involving hydrogen use. However, Jet of flame (ranked 2) which present only uncountable accidents cases in the database. In addition to crew exposure to hydrogen leading to injuries and fatalities has presented only minor severity and that according to the expert due to the fact that seafarers are expected to be aware of safety issues when this technology is finally deployed. In this regard, the correlation analysis results led to state, as an answer to the research question (Q1) and (Q2).

Research question (Q3): What are the lessons learned from accidents database of Hydrogen fuel cell technology in other industries to assess the risks of fuel-cell powered ships?

The research question Q3 refers to lesson learned from accidents in other industries that have occurred in the past. This question was investigated through a comparison analysis of the findings of the accidents database and the Delphi rounds. The Delphi

rankings are compared with the eMARS Database precisely regarding Hydrogen use in various industries. Note that the rankings from the database encompass various industries outside the scope of this study, which is limited to HFC in maritime shipping. There is generally good agreement between the findings of the Delphi and the eMARS Database. Other hazardous events were discussed by the Delphi participants, which is the probability occurrence of the flooding event. This hazard was not mentioned in the data analysis from accidents database. One explanation is that participants have an important experience in the maritime industry. On this basis, the consequence due to the flooding would probably not be severe in comparison to the remaining hazard.

Research question Q4: What are the safety measures that can be implemented to navigate safely on board HFC vessels?

Finally, the main element concerning the safety measures in case of hydrogen leakage is that the leak must be immediately halted to prevent its escalation. To avoid and reduce the effects of hydrogen leaks, suitable gas detection systems for fire extinguishing and detection are expected safety precautions in both fuel storage areas and fuel cell areas. This is a mitigation barrier against hydrogen leakage. Particularly crucial will be the installation of hydrogen-detecting sensors in any hydrogen space to aid in the detection of any unseen leaks. Furthermore, a ventilation system or an inerting system needs to exist in these spaces. For hydrogen-fueled ships, specific barriers need to be designed and adapted to tackle safety issues as well.

Additionally, some barriers such as protective equipment, regulations, practices, and procedures are in place to minimise the risk of crew exposure to hydrogen as a cargo. For example, the IGF Code introduces new training requirements for seafarers in order to protect them from ships using gases or other low flashpoints. In particular, Chapter 14 of the IGC Code stipulates regulations for respiratory and eye protection, breathing apparatus, emergency escape, contaminated showers, eyewash, and protective apparel. However, hydrogen as a fuel on board will require further rigorous provisions. For example, to avoid corrosion in hydrogen pipes, the use of adequate

materials is required. In addition, to maintain continuous monitoring, the strength of various pipes should be monitored regularly. Therefore, further prescriptive design is required to be adopted considering, human exposure limits and, more importantly, the response time of automatic action devices (detectors, shut-off valves, and sniffers to be used during maintenance).

Furthermore, in general, the strategies used for hydrogen applications are based on an event system in order to ensure quick dispersion and a lesser probability of pressure build-up. In this regard, open air in the space storage and fuel cell room might be the most feasible solution to avoid fire and explosion risks. In accordance with the interim IMO Guidelines and the IGF Code, access to hydrogen storage spaces and fuel cell spaces should preferably be directly from the open deck or through airlocks. So, if hydrogen leaks, the people in charge would be safe from problems related to suffocating effect.

5.2 Limitation

In this research study, limitations exist. First, the hazard identification analysis was based on previous accidents involving hydrogen in other industries. These accidents could have different causes and consequences in the maritime context, given the shipboard environment. In further research, other techniques of HAZID could be used, such as risk workshops, personal interviews, and focus group exercises involving different maritime professionals. Another limitation is the limited number of maritime experts used in the Delphi method, six experts. This was due to time limitations. Due to travel restrictions to Covid-19, the online option was used in the interview with experts. Physical interaction with an expert can depict more information, which could bring more benefits to the study. Lastly, the probability calculation was mainly based on expert judgment. In future research, other quantitative methods, such as Fuzzy Logic and Bayesian Network tools, could be used to assist the calculation.

CHAPTER 6: CONCLUSIONS & RECOMMENDATIONS

6.1 Conclusions

Through this study, the researcher has discovered and analysed a number of hazards and their probability occurrence as well as their severity of consequence and safety measures relating to the use of hydrogen fuel cells in maritime application. A number of follow up recommendations are discussed in the following subsection, to improve and make more effective the implementation of this technology safely in the maritime sector.

In accordance with IGF code, an approval process for adaption of alternative fuels and power systems is required to play a crucial role in the journey towards sustainability. It is important to note, in this regard, that these new power systems must provide a comparable level of safety to conventional solutions. Nevertheless, the main dangers associated with using HFC on board ships linked to the risks of fire and explosion. Further, there is a probability that the crews may be exposed to asphyxia environment, or that they may suffer from suffocating effect. As of yet, neither the IMO, Flag States, nor Class Societies have presented any satisfactory rules or requirements for hydrogen fuel cell-powered ships. Having said that, this is still a work in progress.

In addition, The International Maritime Organization (IMO) has started the process of adding fuel cell regulations to the IGF Code. In terms of safety, risk assessment can be used as a means of providing decision makers with information needed to understand factors that can harmfully impact any kind of operations. Since there is a lack of data from the maritime industry particularly when a new technology is about to be implemented, analysing accidents from various industries could support risk assessment process in this field. Further, lesson learnt gathered in relation to the involvement of HFC from previous experience could serve as an advance step to make this technology safer and more sustainable.

While reviewing the lesson learnt from accident database of hydrogen, the researcher found out that applying hazard analysis at early stage will guide the design and the operation of safe HFC ships.

This work interrogated and then discussed the different perspectives to analyse hazards emanating from HFC technology as well as the feasibility of using risk analysis as an aid to decision making in the maritime transportation sector. HFC in the maritime industry is not very different from other industries. Although, the maritime industry is a high-risk industry, it is reasonable to conduct a risk analysis through the analysis of accidents that have been happened from different industries.

A qualitative risk approach was used in this research based on hydrogen incident database which was validated by expert elicitation via Delphi method. The analysis of the interviews questionnaire and incident findings helped the researcher understand the various risks associated with the future operation of hydrogen fuel cell powered ships. Through this research, the researcher was also able to find how can we use accident data of HFC technology from other industries to analyse risks of HFC powered ships and how the experts through their experience and their knowledge in the maritime field could give their expectations regarding the potential hazards associated with hydrogen storage space as well as fuel cell area on board vessels in addition to proposed safety measures that could minimize the risks.

In response to the questions posed by the research, the findings of the research and the analysis of those findings indicate the following:

- A number of potential ignition factors, including electrical sources, mechanical damage, mechanically caused sparks, static discharge, sources of heat, and the auto-ignition of a hydrogen leak, have been identified as being present in the area that houses the fuel cells and the hydrogen storage space. In the meantime, a great number of preventative safety measures have been devised in order to get rid of or lessen the amount of sources of ignition in areas that contain hydrogen, thereby lowering the risk of fires and explosions. These preventative

safety measures include the selection of materials, the utilisation of classified equipment, and maintenance routines for the crew.

- Similarly, it was discovered that leakage presented a risk in both the compartments used for fuel storage and fuel cells. Leakage was found to be a common and even probable threat in a gasoline storage area, and it was concluded that if testing and maintenance of the tanks were not managed effectively, the area would be at risk. Corrosion of system components, connection problems, and manufacturing faults are some of the possible causes that have been indicated. An explosion is the worst-case scenario that could emerge from a breach; it could cause significant damage to the ship or perhaps result in fatalities. The potential repercussions of a leakage can vary. Safety precautions such as A-60 divisions, gas detection, and adequate systems for fire-extinguishing and fire detection are expected to be present in fuel storage areas and fuel cell spaces, respectively, in order to avoid and reduce the effects of the release of hydrogen. As an additional precautionary measure, it will be necessary to install either a ventilation system or an inerting system in the areas in question.
- Inherent in the tiny size of hydrogen molecules is the risk of permeation. Hydrogen storage tank materials should be evaluated to determine their permeation rates to guarantee safe levels of hydrogen storage. The performance of metal lining is anticipated to be superior to that of polymer lining in this respect. It is important that the ventilation system in the hydrogen storage area be built to control the expected permeation. Using double-walled pipes and butt-welded connections could help reduce leaks in the piping system. Some additional precautions against and amelioration of permeation were also identified.
- Flooding hazard was also identified by Delphi rounds in hydrogen tank spaces and fuel cell spaces; however, this hazard was not emphasized in hydrogen incident database.

- Any hardware utilised in such an arrangement must be suitable for use at sea. There were also concerns brought up about vibrations and sea water exposure. To prove their worth in a marine setting, components must undergo rigorous testing and certification.

The next sub-section gives recommendations which MSEAs future researchers can follow to conduct hazard analysis to explore the impact of hydrogen and fuel cells on the maritime industry.

6.2 Recommendations

To make the use of HFC safer on-board ships, prepare the crew, and ensure the safety of life at sea, a risk assessment is required. By analyzing the risks inherited from HFC-fuelled ships, and by providing risk information to shipping personnel, we can gain a deeper understanding of this new technology. In the process of risk assessment, a list of areas where further studies and work are recommended is presented below:

- Additional evaluation of the identified risks, particularly the risk of explosion associated with hydrogen leakage.
- A thorough evaluation of the cost of the identified safety measure and its effect on the identified risks.
- In order to understand more clearly the causes and consequences of hydrogen leakage scenario, the application of bow tie model would be more effective to develop prevention and mitigation measures.
- Further investigation into the bunkering of hydrogen and its associated safety precautions.
- Analyse the development of hydrogen installation costs in light of the progress of both technology and legislation.
- Collect incident information in hydrogen industry from various incidents databases.
- Create a checklist for preventing maritime incidents from occurring based on the effects, causes, and consequences in different industries.

- More research into past failures is required, together with the application of the lessons learned, in order to better improve risk assessment in the future.
- Based on the findings of this study, a quantitative risk assessment could be developed.

Reference

- Adamson, K.A. (2005). Opening doors to fuel cell commercialization: Fuel Cell and Marine Application. Retrieved 29 July 2009 from http://www.fuelcelltoday.com/media/pdf/archive/Article_951_FC_Marine.pdf
- Ahmadi, P., Torabi, S. H., Afsaneh, H., Sadegheih, Y., Ganjehsarabi, H., & Ashjaee, M. (2020). The effects of driving patterns and PEM fuel cell degradation on the lifecycle assessment of hydrogen fuel cell vehicles. *International Journal of Hydrogen Energy*, 45(5), 3595-3608.
- Ammar, N. R. (2019). An environmental and economic analysis of methanol fuel for a cellular container ship. *Transportation Research Part D: Transport and Environment*, 69, 66-76.
- Annex, I. M. O. (1997). 19-Resolution MEPC. 203 (62). Amendments to the annex of the protocol of.
- Apter, A., Bracker, A., Hodgson, M., Sidman, J., & Leung, W. Y. (1994). Epidemiology of the sick building syndrome. *Journal of Allergy and Clinical Immunology*, 94(2), 277-288.
- Ash, N., & Scarbrough, T. (2019). Sailing on solar: Could green ammonia decarbonise international shipping. *Environmental Defense Fund: London, UK*.
- Arun, P. A., Tauseef, S. M., & Uniyal, U. (2022). Comparison of Accident Databases and Analysis of Past Industrial Accidents in the Chemical Process Industry. *Engineering, Technology & Applied Science Research*, 12(4), 8922-8927.
- Bagotsky, V.S. (2009). Fuel Cells: Problem and Solution. *Canada: John Wiley & Sons, Inc.*
- Balcombe, P., Brierley, J., Lewis, C., Skatvedt, L., Speirs, J., Hawkes, A., & Staffell, I. (2019). How to decarbonise international shipping: Options for fuels, technologies and policies. *Energy conversion and management*, 182, 72-88.
- Baroutaji, A., Wilberforce, T., Ramadan, M., & Olabi, A. G. (2019). Comprehensive investigation on hydrogen and fuel cell technology in the aviation and aerospace sectors. *Renewable and sustainable energy reviews*, 106, 31-40.
- Basu, S. (2007). Fuel cell science and technology (pp. 188-215). Anamaya Publishers, New Delhi, India.

- Beaudrie, C. E., Kandlikar, M., & Ramachandran, G. (2016). Using expert judgment for risk assessment. In *Assessing Nanoparticle Risks to Human Health* (pp. 91-119). William Andrew Publishing.
- Boethling, R. S., Sommer, E., & DiFiore, D. (2007). Designing small molecules for biodegradability. *Chemical reviews*, *107*(6), 2207-2227.
- Borman, G. L., & Ragland, K. W. (1998). *Selected Material from Combustion Engineering: ME 140 Combustion Processes: Customized for University of California-Berkeley*. McGraw-Hill.
- Braga, L. B., Silveira, J. L., da Silva, M. E., Machin, E. B., Pedroso, D. T., & Tuna, C. E. (2014). Comparative analysis between a PEM fuel cell and an internal combustion engine driving an electricity generator: Technical, economic and ecological aspects. *Applied Thermal Engineering*, *63*(1), 354-361.
- Braun, V., & Clarke, V. (2012). *Thematic analysis*. American Psychological Association.
- Cao, H., Georgopoulos, P., Capurso, G., Pistidda, C., Weigelt, F., Chaudhary, A. L., ... & Klassen, T. (2018). Air-stable metal hydride-polymer composites of Mg (NH₂)₂-LiH and TPXTM. *Materials today energy*, *10*, 98-107.
- Chen, L., & Guan, W. (2021). Safety Design and Engineering Solution of Fuel Cell Powered Ship in Inland Waterway of China. *World Electric Vehicle Journal*, *12*(4), 202.
- Chuahy, F. D., & Kokjohn, S. L. (2019). Solid oxide fuel cell and advanced combustion engine combined cycle: A pathway to 70% electrical efficiency. *Applied energy*, *235*, 391-408.
- Cropper, M. (2004). Opening doors to fuel cell commercialization: Fuel cells in ocean going yacht. Retrieved August 2, 2010 from http://www.fuelcelltoday.com/media/pdf/archive/Article_752_FuelCellsinyachts0304.pdf
- Crowe, B.J. (1973). Fuel Cells: A Survey. Retrieved 3 August 2010 from http://ntrs.nasa.gov/archive/nasa/casi.ntrs.nasa.gov/19730017318_1973017318.pdf
- Dhokal, Kerry. "NVivo." *Journal of the Medical Library Association* 110, no. 2 (2022): 270-272.

- Dimitriou, P., & Tsujimura, T. (2017). A review of hydrogen as a compression ignition engine fuel. *International Journal of Hydrogen Energy*, 42(38), 24470-24486. <https://doi.org/10.1016/j.ijhydene.2017.07.232>
- E4ship partners. (2009). Retrieved 18 August 2010 from <http://www.e4ships.de/e4ships-partners.html>
- Eastman. Marlotherm SH Heat Transfer Fluid MSDS, 2020, available from: <https://www.eastman.com/Pages/ProductHome.aspx?product=71114174&pn=Marlotherm+SH+Heat+Transfer+Fluid>.
- EG&G Technical Services, Inc. (2004). Fuel cells handbook, 7th ed. US: DOE
- EIA, U. (2017). Energy Information Administration, "International Energy Outlook 2017," 2017.
- Facts about FellowSHIP and the Viking Lady: Sustainable energy generation for marine use. (2009).
- FCS "Alsterwasser" starts into new season. (2009). Zemship Newsletter No.2–2009/05
- Five lessons to learn on hydrogen as ship fuel - DNV. (n.d.). Retrieved March 12, 2022, from <https://www.dnv.com/expert-story/maritime-impact/Five-lessons-to-learn-on-hydrogen-as-ship-fuel.html>
- Garmsiri, S., Dincer, I., & Naterer, G. F. (2013). Comparisons of automotive, locomotive, aircraft and marine conversion to hydrogen propulsion using six-sigma methodologies. *International journal of hydrogen energy*, 38(5), 2020-2028.
- Georgeff, E., Mao, X., Rutherford, D., & Osipova, L. (2020). Liquid hydrogen refueling infrastructure to support a zero-emission US–China container shipping corridor. *Working Paper*, (2020-24).
- Ghenai, C.; Bettayeb, M.; Brdjanin, B.; Hamid, A.K. Hybrid solar PV/PEM fuel Cell/Diesel Generator power system for cruise ship: A case study in Stockholm, Sweden. *Case Stud. Therm. Eng.* 2019, 14, 100497.
- Goerlandt, F., Khakzad, N., Reniers, G., 2017. Validity and validation of safety-related quantitative risk analysis: a review. *Saf. Sci.* 99, 127–139.
- Gomez Trillos, J. C., Wilken, D., Brand, U., & Vogt, T. (2019). HySeas III: The World's First Sea-Going Hydrogen-Powered Ferry—A Look at its Technical

Aspects, Market Perspectives and Environmental Impacts. *Nutzung Regenerativer Energiequellen und Wasserstofftechnik 2019*, 57-80.

- Gupta, U., & Clarke, R. (1996). Theory and application of the Delphi technique: A bibliography (1975-1994). *Technological Forecasting and Social Change*, 53, 185-211.
- Granath, B. (2017). Liquid hydrogen—The fuel of choice for space exploration. Washington, DC: National Aeronautics and Space Administration. Retrieved from <https://www.nasa.gov/content/liquid-hydrogen-the-fuel-of-choice-for-space-exploration>.
- Hall, D., Pavlenko, N., & Lutsey, N. (2018). Beyond road vehicles: Survey of zero-emission technology options across the transport sector. *International Council on Clean Transportation Working Paper*, 11.
- Heffel, J. W. (2003). NOx emission and performance data for a hydrogen fueled internal combustion engine at 1500rpm using exhaust gas recirculation. *International Journal of Hydrogen Energy*, 28(8), 901-908.
- Helmer, O., Brown, B., Gordon, T., 1966. Social Technology. *Basic Books, New York*.
- Hilal, A. H., & Alabri, S. S. (2013). Using NVivo for data analysis in qualitative research. *International interdisciplinary journal of education*, 2(2), 181-186.
- Huberman, A. M., & Miles, M. B. (1994). Data management and analysis methods.
- Hydrogen and fuel cell in marine transport. (2008). Retrieved July 27, 2010 from http://www.ika.rwthachen.de/r2h/index.php?title=Hydrogen_and_Fuel_Cells_in_Marine_Transport&oldid=6019
- IEA/OECD. (2004). Hydrogen & fuel cell : *Review of national R & D program. France: IEA/OECD*
- IMO. (2009). Climate change on the agenda as UN agency leaders meet at IMO. Retrieved 8 August 2010 from http://www.imo.org/newsroom/mainframe.asp?topic_id=1773&doc_id=11336
- IMO. (2013). Revised Guidelines for Formal Safety Assessment (FSA) for Use in the IMO Rule-Making Process. London: Author.
- IMO. (2014). Third IMO GHG study 2014. Executive summary and final report, MEPC 67/6/INF.3., International Maritime Organization, London.

- Inal, O. B., & Deniz, C. (2018, April). Fuel cell availability for merchant ships. *In Proceedings of the 3rd International Naval Architecture and Maritime Symposium* (pp. 907-916).
- Japan Transport Safety board. (2021). statistics of marine accident. https://www.mlit.go.jp/jtsb/statistics_mar.html
- Johnson, W. G. (1975). MORT: The Management Oversight and Risk Tree. *Journal of Safety Research*.
- Kingston, J., Koornneef, F., Van den Ruit, J., Frei, R., & Schallier, P. (2002). NRI MORT User's Manual. *For Use with the Management Oversight and Risk Tree Analytical Logic Diagram*
- Kvaløy, J. T., & Aven, T. (2005). An alternative approach to trend analysis in accident data. *Reliability Engineering & System Safety*, 90(1), 75-82.
- Lan, R., & Tao, S. (2014). Ammonia as a suitable fuel for fuel cells. *Frontiers in energy research*, 2, 35.
- Li, F., Yuan, Y., Yan, X., Malekian, R., & Li, Z. (2018). A study on a numerical simulation of the leakage and diffusion of hydrogen in a fuel cell ship. *Renewable and Sustainable Energy Reviews*, 97, 177-185.
- Lindstad, H., Asbjørnslett, B. E., & Strømman, A. H. (2012). The Importance of economies of scale for reductions in greenhouse gas emissions from shipping. *Energy policy*, 46, 386-398.
- Linstone HA, Turoff M. The Delphi method: techniques and applications, vol. 29. Reading: Addison-Wesley; 1975.
- Maeda, T., Yokoyama, K., Hisatome, N., Ishiguro, S., Hirokawa, K. & Tani, T. (2006). Fuel Cell AUV "URASHIMA". *Mitsubishi Heavy Industries, Ltd. Technical Review* , 43 (1).
- Marine application of fuel cells. (nd.). Retrieved 13 August 2010 from http://ec.europa.eu/research/energy/pdf/efchp_fuelcell39.pdf
- Martins, M. R., Pestana, M. A., & Droguett, E. A. L. (2020). A Methodology for assessing the probability of occurrence of undesired events in the Tietê–Paraná Inland Waterway Based on Expert Opinion. *Risk Analysis*, 40(6), 1279-1301.

- Markowski, J., & Pielecha, I. (2019). The potential of fuel cells as a drive source of maritime transport. In *IOP Conference Series: Earth and Environmental Science* (Vol. 214, No. 1, p. 012019). IOP Publishing.)
- Mashhadimoslem, H., Ghaemi, A., Palacios, A., & Behroozi, A. H. (2020). A new method for comparison thermal radiation on large-scale hydrogen and propane jet fires based on experimental and computational studies. *Fuel*, 282, 118864.
- Meredith J, Raturi A, Amoako-Gyampah K, Kaplan K. Alternative research paradigms in operations. *J Oper Manage* 1989; 8:297–327.
- McConnell, V.P. (2010). Now, voyager? The increasing marine use of fuel cells. *Fuel cells bulletin*, May 2010, pp. 12-17.
- Mirza, N. R., Degenkolbe, S., & Witt, W. (2011). Analysis of hydrogen incidents to support risk assessment. *International journal of hydrogen energy*, 36(18), 12068-12077
- Mirza, N. R., Degenkolbe, S., & Witt, W. (2011). Analysis of hydrogen incidents to support risk assessment. *International journal of hydrogen energy*, 36(18), 12068-12077.
- Mokhatab, S., Mak, J., Valappil, J., & Wood, D. A. (2013). *Handbook of liquefied natural gas*. Gulf Professional Publishing.
- National Research Council, & Committee on Acute Exposure Guideline Levels. (2010). Xylenes Acute Exposure Guideline Levels. In *Acute Exposure Guideline Levels for Selected Airborne Chemicals: Volume 9*. National Academies Press (US).
- Newsholme, G. (2004). Fuel cells – hazard and risk management. Retrieved 22 November 2009 from <http://www.hse.gov.uk/foi/internalops/hid/din/548.pdf>
- Nowatzki, J. (2008). Anhydrous Ammonia: *Managing the Risks*.
- Nylander, J. (2021). Fire hazards onboard unmanned vessels: fire protection of unmanned ships with conventional solutions.
- NYK Releases Exploratory Design for NYK Super Eco Ship 2030. (2009). Retrieved 3 August from http://www.nyk.com/english/release/31/NE_090422.html
- Oates, B. J., 2005. *Researching information systems and computing*, Thousand Oaks, CA: Sage.

- Okoli, C., & Pawlowski, S. D. (2004). The Delphi method as a research tool: an example, design considerations and applications. *Information & management*, 42(1), 15-29.
- Paczkowski, B. (2004). Ballistic Testing of Pressurized Hydrogen Storage Cylinders. In *Power Sources Conference* (pp. 1-4).
- Pakbeen, H. (2018). Comparative Study of Leading Cruise Lines' Sustainability Practices and Environmental Stewardship in Contribution to SDGs' Sea and Water Conservation Goal. *European Journal of Sustainable Development*, 7(3), 507-507.
- Pratt, J. W., & Klebanoff, L. E. (2016). Feasibility of the SF-BREEZE: a zero-emission, hydrogen fuel cell, high-speed passenger ferry.
- Pratt, J. W., & Klebanoff, L. E. (2018). *Optimization of Zero Emission Hydrogen Fuel Cell Ferry Design, with Comparisons to the SF-BREEZE (No. SAND2018-0421)*. Sandia National Laboratories.
- Rattazzi, D., Rivarolo, M., & Massardo, A. F. (2021). An innovative tool for the evaluation and comparison of different fuels and technologies onboard ships. In *E3S Web of Conferences (Vol. 238)*. EDP Sciences.
- Rigas, F., & Amyotte, P. (2012). *Hydrogen safety*. CRC Press.
- Saffers, J. B., & Molkov, V. V. (2014). Hydrogen safety engineering framework and elementary design safety tools. *International journal of hydrogen energy*, 39(11), 6268-6285.
- Sasaki, K., Susuki, K., Iyoshi, A., Uchimura, M., Imamura, N., Kusaba, H., ... & Jingo, N. (2006). H₂S poisoning of solid oxide fuel cells. *Journal of the Electrochemical Society*, 153(11), A2023.
- Schmidt, R. (1997). Managing Delphi surveys using nonparametric statistical techniques. *Decision Sciences*, 28 (3), 763-774.
- Skulmoski, G. J., Hartman, F. T., & Krahn, J. (2007). The Delphi method for graduate research. *Journal of Information Technology Education: Research*, 6(1), 1-21.
- Smithsonian Institution. (2004). PEM Fuel Cells. Retrieved May 1, 2010 from <http://americanhistory.si.edu/fuelcells/pem/pemmain.htm>
- Spada, M., Burgherr, P., & Rouelle, P. B. (2018). Comparative risk assessment with focus on hydrogen and selected fuel cells: Application to Europe. *International Journal of Hydrogen Energy*, 43(19), 9470-9481.

- Subramanian V., Mallikarjuna J.M., and Ramesh A., Intake charge dilution effects on control of nitric oxide emission in a hydrogen fuelled SI engine. *International Journal of Hydrogen Energy*, 2007, 32: 2043–2056.
- Stoneburner, G., Goguen A., & Feringa, A., 2002. Risk Management Guide for Information Technology Systems. National Institute of Standards and Technology, *NIST Special Publication*.
- Streveler, R. A., Miller, R. L., Nelson, M. A., Geist, M. R., & Olds, B. M. (2008). Developing an instrument to measure engineering student misconceptions in thermal and transport science. *Journal of Engineering Education*.
- Tauseef, S. M., Abbasi, T., & Abbasi, S. A. (2011). Development of a new chemical process-industry accident database to assist in past accident analysis. *Journal of loss prevention in the process industries*, 24(4), 426-431.
- Takeo, K., Okabayashi, K., Kouchi, A., Nonaka, T., Hashiguchi, K., & Chitose, K. (2007). Dispersion and explosion field tests for 40 MPa pressurized hydrogen. *International Journal of Hydrogen Energy*, 32(13), 2144-2153.
- The CMB Group. Hydroville [Internet]. 2020 [cited 2020 Apr 22]. Available from: <http://www.hydroville.be/en/>
- Turoff, M., & Linstone, H. A. (2002). The Delphi method-techniques and applications.
- Tronstad, T., Åstrand, H. H., Haugom, G. P., & Langfeldt, L. (2017). Study on the use of fuel cells in shipping. *European Maritime Safety Agency*.
- Tronstad, T., Åstrand, H. H., Haugom, G. P., & Langfeldt, L. (2017). Study on the use of fuel cells in shipping. *European Maritime Safety Agency*.
- U.S. Congress, Office of Technology Assessment. (1986). Marine Applications for Fuel Cell Technology—A Technical Memorandum, *OTA-TM-O-37*. Washington, DC: U.S. Government Printing Office.
- Ural, Z., Gencoglu, M. T., & Gumus, B. (2007, July). Dynamic simulation of a PEM fuel cell system. In *Proceedings of 2nd International Hydrogen Energy Congress and Exhibition* (pp. 1-12.)
- Valdengo, J., LaChance, E., & Andrews, D. (2018). Training Special Operations Forces to Conduct Maritime Surveillance: A New Approach. *Special Operations Journal*, 4(2), 202-212.

- Verbruggen, S. W. (2015). TiO₂ photocatalysis for the degradation of pollutants in gas phase: From morphological design to plasmonic enhancement. *Journal of Photochemistry and Photobiology C: Photochemistry Reviews*, 24, 64-82.
- Verma, A., & Scott, K. (2010). Development of high-temperature PEMFC based on heteropolyacids and polybenzimidazole. *Journal of Solid-State Electrochemistry*, 14(2), 213-219.
- Vogler, F. (2008). Safety and classification procedures of fuel cell ships. Presented in ZEMSHIPS Conference, H2EXPO, CCH Hamburg, 2008-10-23. Retrieved 17 August 2010 from http://www.zemships.eu/de/DateienDownloadbereich/Conference/P5_Zemships_conference.pdf
- Wallenius Wilhelmsen. (2010). Green Flagships. Retrieved 4 August 2010 from http://www.2wglobal.com/www/pdf/Green_Flagship.pdf
- Weaver, G. (2002). World Fuel Cells: An Industry Profile with Market Prospects to 2010. UK: Elsevier Advanced Technology.
- Wen, J. X., Marono, M., Moretto, P., Reinecke, E. A., Sathiah, P., Studer, E., ... & Melideo, D. (2022). Statistics, lessons learned and recommendations from analysis of HIAD 2.0 database. *International Journal of Hydrogen Energy*, 47(38), 17082-17096.
- Wijayanto, D. (2020). The development of an operational KPI for energy efficiency ship operation.
- Wojcik, A., Middleton, H., & Damopoulos, I. (2003). Ammonia as a fuel in solid oxide fuel cells. *Journal of Power Sources*, 118(1-2), 342-348.
- Xiao, M., Liang, S., Han, J., Zhong, D., Liu, J., Zhang, Z., & Peng, L. (2018). Batch fabrication of ultrasensitive carbon nanotube hydrogen sensors with sub-ppm detection limit. *ACS sensors*, 3(4), 749-756.
- Yalcin, E., & Suner, M. (2020). The changing role of diesel oil-gasoil-LPG and hydrogen-based fuels in human health risk: A numerical investigation in ferry ship operations. *International journal of hydrogen energy*, 45(5), 3660-3669.
- Yin, R. K. (2003). Designing case studies. *Qualitative research methods*, 5(14), 359-386.
- Zaloom, V., & Subhedar, V. (2008). Use of the Delphi Method to prioritize events impacting operations in the maritime domain. Lamar University, Texas, USA.

Appendices

Appendix A: WMU Research Ethics Committee Protocol



<i>WMU Research Ethics Committee Protocol</i>	
Name of principal researcher:	Chahrazed Tigha
Name(s) of any co-researcher(s):	N.A
If applicable, for which degree is each researcher registered?	MSC in Maritime Affairs Maritime, safety and environmet administrartion (MSEA)
Name of supervisor, if any:	Prof.Chongju CHAE
Title of project:	Hazard analysis of hydrogen fuel cell ships using land based accident data and elicitation of experts
Is the research funded externally?	No
If so, by which agency?	N.A
Where will the research be carried out?	The research will be carried out in SWEDEN
How will the participants be recruited?	Classification societies :DNV,BV and shipping company
How many participants will take part?	Around 20
Will they be paid?	No
If so, please supply details:	N.A
How will the research data be collected (by interview, by questionnaires, etc.)?	Experts group Interview questions
How will the research data be stored?	Research data will be stored in my personal laptop, google drive, and flash memory with a strong password
How and when will the research data be disposed of?	The data will be deleted from my laptop and other storage unites upon completion of my MSC studies , a degree scheduled to be awarded 30 October 2022
Is a risk assessment necessary? If so, please attach	No

Signature(s) of Researcher(s):

Chahrazed Tigha

Date: 2022.07.19

Signature of Supervisor:

Prof. Chongju CHAE

Date: 2022.07.19

Please attach:

- A copy of the research proposal
- A copy of any risk assessment
- A copy of the consent form to be given to participants
- A copy of the information sheet to be given to participants
- A copy of any item used to recruit participants

Appendix B: Personal Interview

Interview Consent Form

Dear Participant,

Thank you for agreeing to participate in this research Interview, which is carried out in connection with a Dissertation which will be written by the interviewer, in partial fulfilment of the requirements for the degree of Master of Science in Maritime at the World Maritime University in Malmo, Sweden.

The topic of the Dissertation: **HAZARD ANALYSIS OF HYDROGEN FUEL CELL SHIPS USING LAND BASED ACCIDENTS DATA AND ELICITATION OF EXPERTS**

The information provided by you in this interview will be used for research purposes and the results will form part of a dissertation, which will later be published online in WMU's digital repository (maritime commons) subject to final approval of the University and made available to the public. Your personal information will not be published. You may withdraw from the research at any time, and your personal data will be immediately deleted.

Anonymised research data will be archived on a secure virtual drive linked to a World Maritime University email address. All the data will be deleted as soon as the degree is awarded. Your participation in the interview is highly appreciated.

Student's name: Chahrazed Tigha

Specialization: Maritime Safety and Environment Administration (MSEA)

Email address: w1011299@wmu.se

* * *

I consent to my personal data, as outlined above, being used for this study. I understand that all personal data relating to participants is held and processed in the strictest confidence, and will be deleted at the end of the researcher's enrolment.

Name:.....

Signature:.....

Date:.....

Interview questions

Company or organization:

Position:

Experience (by year):

-
- 1. Several hazards have been identified through literature reviews, such as leakages, ignition, asphyxia, corrosion, fires, explosions, and flammability...etc. Could you please elaborate on the safety hazards associated with hydrogen fuel cell in ship based on your experience?**

 - 2. a. Could you cite some factors leading to accidents on board ship with regard to HFC use?**

 - 2. b. What hazards associated with this technology have the potential to result in the worst consequences on board ships?**

 - 3. Could you cite which are the most dangerous areas related to the use of HFC on board vessel? And why?**

 - 4. Could you cite which are the most significant risks (the consequence of the hazard) when dealing with HFC?**

 - 5. In general, the HFC system on ships consists of 6 spaces, namely bunkering station, fuel transfer space, hydrogen storage space, fuel cell space, machinery space and battery space. Which from those spaces are the most hazardous spaces on board ships? Could you elaborate more on the types of hazards that may be found in these risky areas?**

 - 6. Could you please elaborate on their origin (pipeline, leakages, static electricity...)?**

 - 7. Could you please comment on the contribution of human error in the occurrence of fire and explosion accidents on board HFC vessels? Could you please give an example of accident you have faced during your career where human error was the main contributing factor?**

 - 8. Could you please comment on the adequacy of the current training of the crew in order to operate safely hydrogen fuel cell ships?**

9. Could you please comment on the level of safety awareness / safety culture of ship's crew to mitigate the emerging risks coming with this new technology (HFC)?

10. Could you please define the needed safety barriers (as classified below) to mitigate the hazards associated with the use of HFC on board merchant ships? Could please elaborate on their effectiveness?

- people barrier**
 - Management barrier**
 - material barriers**
 - work and task barrier**
 - environment barriers**
-

Any Comments:

11. If operator error of HFC acts as barrier, which root cause can be?

12. If management aspect acts as barrier, which root cause can be?

13. If technical aspect acts as barrier, which root cause can be?

14. If inadequate maintenance aspect acts as barrier, which root cause can be?

15. While this alternative fuel (HFC) comes with its own risks and challenges, how does your organisation at managerial level attempt to mitigate and find solution toward safe use of HFC?

16. When talking about accidents that have been occurred in the industry related to the use of hydrogen fuel cell (HFC), to what extent the lessons learned could help maritime industry to mitigate risks associated with HFC?

End of questions

Appendix C: Screenshot of excel eMARS Database

A	B	C	D	E	F	G	H	I	J	K	L	M
Accident ID	Accident Title	Event Type	Industry Type	Accident Description	Installation	Causes of the accident	Consequences	Emergency response	Lessons learned			
Ac.01	Gas leak in refinery	Near Miss	Petrochemical / Oil Refinery	A gas leak occurred	Isomerisation unit	The accident happened	The plant had to be shut d	The controlroom shut	One of the recommendations for working			
Ac.02	Release of hydrogen chlor	Major Accident	General chemicals manufact	19 persons were into the trichloro (methyl) sila		operation error	Release of hydrogen chlori	Establishment of a s	Measures to prevent recurrence. Informa			
Ac.03	Release of hydrogen and	Near Miss	General chemicals manufact	Due to a leaky fitting, Operating process: Proc		Leaky fitting.	No damage to property as	Closure of the operat	Confirmation of the manner in which all			
Ac.04	Release of hydrogen sulfi	Near Miss	Power generation, supply an	Only maize silage is u	Operating process: Trans	The event is linked to a	Two injured persons.	After the event, the fil	The relevant substance handling process is			
Ac.05	Explosion, with consequ	Major Accident	General chemicals manufact	Explosion, with conse washing station of an or		Operation error (operat	The event caused consider	not given	relevant operations of the containers are			
Ac.06	Release of Chlorine and	Major Accident	Processing of metals	SYSTEM ORIGINATI	The accident occurred in	INITIATING EVENT AND	EFFECTS ON PEOPLE: 10 pe	INTERNAL TO THE EST	MEASURES TO PREVENT ANY RECURRING			
Ac.07	Release of titanium tetra	Major Accident	General chemicals manufact	ACCIDENT CASE HIST	The accident occurred in	CAUSES: The accident w	MATERIAL LOSS: The raw m	INTERNAL TO THE EST	MEASURES TO PREVENT ANY RECURRING			
Ac.08	Explosion of a tank follo	Major Accident	Other activity (not otherwis	During welding activit	The accident occurred at	The major cause of the	The explosion broke off the	The following immedi	order to prevent such accidents in the future			
Ac.09	Fire in a polyurethane fo	Major Accident	Plastic and rubber manufact	Fire broke out in a 60 Polyurethane silo fo		The waste panel crush	Release of smoke and toxic	The internal safety tes	the following technical improvements have			
Ac.10	Flaring of ethylene from	Major Accident	Petrochemical / Oil Refiner	In a petrochemical pl	Digester	Lightning (natural cause	Atmospheric pollution	Flaring	The flaring device was faulty so the			
Ac.11	Explosion inside the com	Major Accident	Plastic and rubber manufact	In the morning of Sept		Inadequate Design of P			A specialist should be located in back of			
Ac.12	Substance release, expl	Major Accident	General chemicals manufact	Following an overloa	Damaged component: h	Overload fracture to a	Pressure and heat damage	Internal: Checking th	The operator must be aware that the steps of			
Ac.13	Explosion and fire in a di	Major Accident	General chemicals manufact	SUMMARY: approu Distillation Unit		FAILURE ANALYSIS: The	Material Loss: Affected Area	EMERGENCY RESPON	Operational Avoid the in-fatal (distillation) o			
Ac.14	Release of hydrogen chlor	Other Event	Production and storage of p	The accident: hydroge	In the factory benzoyl cl				According to the declarati			
Ac.15	Fire involving propanol is	Major Accident	General chemicals manufact	Fire involving propan	Fire in the hydration inst				When the accident oc			
Ac.16	Hydrogen sulfide leak fr	Other Event	Production and manufactur	An operator died afte	The valve from the stor				Another operator act			
Ac.17	Explosion and a fire in a	Major Accident	Production and storage of p	The accident occur	The process scheme use				The synthesis operatio			
Ac.18	Deadly fire due to hydro	Major Accident	General chemicals manufact	ACCIDENT CASE HIST	The accident occurred in	CAUSES: The causes ha	EFFECTS ON PEOPLE: Inside	INTERNAL TO THE EST	Measures to prevent recurrence. When the			
Ac.19	Accidental release from	Major Accident	General chemicals manufact	SAFETY SYSTEMS OR	The accident occurred in	INITIATING EVENT AND	People - Remarks: Inside	INTERNAL TO THE EST	Measures to prevent recurrence. After the			
Ac.20	Explosion during the proc	Other Event	Other activity (not otherwis	An explosion occur	not given				Professional Fire Figh			
Ac.21	Plant destroyed by a fir	Major Accident	General chemicals manufact	A reaction was being	not given				The fire that damaged			
Ac.22	A worker died when doin	Major Accident	Mining activities (tailings &	A worker died when T	The accident happened				The accid The company had an i			
Ac.23	Explosion and release of	Major Accident	Processing of metals using	Explosion and release	Waste water treatment				The explosion of a char			
Ac.24	Fire of an ethyl chloride	Major Accident	General chemicals manufact	At 20:15 of February	The accident involved a							
Ac.25	HCl cloud dispersion due	Major Accident	Electronics & electrical engi	At 20:22 of 26 April	The HCl cloud which was							
Ac.26	Dispersion of a hydrogen	Major Accident	General chemicals manufact	ENVIRONMENTAL AB	The accident occurred in							
Ac.27	Secondary Benzene Pollu	Major Accident	General chemicals manufact	At 11:00 a.m. on Nov	organic workshop							
Ac.28	Intoxicatory of vapors fr	Major Accident	General chemicals manufact	After the due conside	On the territory of the							
Ac.29	Explosion and substance	Near Miss	General chemicals manufact	On 11 Septemb	At the time of the incid							
Ac.30	Deflagration reactor acci	Major Accident	General chemicals manufact	The 08.27.2015 day,	Arteixo Chemical Compa							

A	B	C	D	E	F	G	H	I	J	K	L	M
Ac.120	Explosion and fire on the	Major Accident	Petrochemical / Oil Refiner	Shortly after 6pm, on	The amine regeneration	 Lack of knowledge	Explosion incident	An explo	The fire was brought	the	Believes that the deaths were preventable	
Ac.121	Release of CS-C6 n-paral	Major Accident	Petrochemical / Oil Refiner	On 17 July 2010 a pip-	Ship unloading -	The cause of the discha	Material damage: Comp	On-site:Liquid covered			Immediate actions, increased patrols 1 Up	
Ac.122	Explosion in a glyoxylic a	Major Accident	General chemicals manufact	Explosion in a produc	The process involves ozo	Unclear	besides the injuries (20 pe	The fire was extinguish			cause, despite intense efforts to find the	
Ac.123	Accident for cyanide exp	Major Accident	General chemicals manufact	One worker died from	Sample point for flare sy	Not clear as to what pr	One fatality. No other inju	On-site emergency pla			Measures to prevent recurrence: Inspecti	
Ac.124	Fire caused by the ruptu	Major Accident	General chemicals manufact	A rupture of the react no	given	Still under investigation -	No personal injuries -	Fire On site emergency orga			cause given	
Ac.125	Release of hydrogen and	Major Accident	General chemicals manufact	Release of hydrogen -	adsorber	human error (during rec	The event caused material	After the alarm proce			Modification of the cooling system (cont	
Ac.126	Workers were exposed to	Near Miss	Production and manufactu	An explosion occurre	An explosion occurred a	The explosion occurre	One worker was admitted	When a worker lost c			In order to prevent similar accidents, the an	
Ac.127	Escape of a jet of gas	Major Accident	Production and storage of p	ACCIDENT CASE HIST	The accident occurred du	CAUSES:Investigation re	EFFECTS ON PEOPLE:2 wor	INTERNAL TO THE EST			Measures to prevent recurrence: After the an	
Ac.128	Leak in a hydrogen fluor	Major Accident	General chemicals manufact	A leak in a pipeline ca	The leak occurred in a lin	The leak was caused by	ON-SITE: 14 people (all thi	ON-SITE: Alarm was g			When hydrogen fluoride can be contaminat	
Ac.129	Waste storage, treatment	Major Accident	Petrochemical / Oil Refiner	Release of hydrogen	Extraction was taking pla	not given	not given	Apart from the organi			cause given	
Ac.130	Fire devastated a part of	Other Event	Other activity (not otherwis	A fire devastated a pl	Several toxic substances	not given	The engine driver of the tr	not given			transport accidents, either with actual dam	
Ac.131	Release of hydrogen sulph	Near Miss	Chemical installations - oth	On 24 June 2010 aris	Plant operation: process	An employee had open	1 worker was injured.	The internal alarm wa			the defect glass container was removed and	
Ac.132	Rupture of a gas scrubber	Major Accident	Manufacture of food produ	Rupture of a gas scrub	Liquid trimethylamine o	Human error - failure to	The neighbours of the Val	dilution of the cloud			modification by the industries is essential. Re	
Ac.133	Fire in the pre-heating	Major Accident	Petrochemical / Oil Refiner	There was a fire in th	The fire broke out in the	Inspection plan of the c	Human consequences:Two	The DRIRE launched a			The accident is a reminder of the importance	
Ac.134	Downfall of a tank conta	Major Accident	General chemicals manufact	Downfall of a tank cc	30 mft glass fibre reinfor	Corrosion of a leg of th	Tank rupture. Production	Shut-down of the produc			use up using polyester tanks for this kind	
Ac.135	Release of carbon mono	Major Accident	Petrochemical / Oil Refiner	At approx. 9:30 hrs a	None of the installations	During the start-up pha	8 persons affected were	2 980 persons present			In order to reduce the probability of recurr	
Ac.136	Overfilling of a tank caus	Major Accident	Processing of metals	SAFETY SYSTEMS OR	not given	INITIATING EVENT AND	2 persons hospitalized by	n INTERNAL TO THE EST			Measures TO PREVENT ANY RECURRING I	
Ac.137	Explosions in a reactor	Major Accident	General chemicals manufact	ACCIDENT CASE HIST	The accident occurred in	CAUSES:An analysis of	MATERIAL LOSS:The exten	INTERNAL TO THE EST			Measures to prevent recurrence: After this a	
Ac.138	Explosion of a cryogenic	Major Accident	Petrochemical / Oil Refiner	Release of hydrocarb	During the start-up oper	The bursting of a tank w	Large material damages	(c) The emergency shut-			down indication	
Ac.139	Explosion of a road tank	Other Event	Manufacture of food produ	Explosion of a road tank	Lorry tank of 7m3	There may have a piece	15 people felt unwell and	2 Evacuation of lorries			ensure that tanks contain no other product	
Ac.140	Residual butane amox	Major Accident	Processing of metals	The accident happen	During transport of the m	An unintentional evole	Area concerned -	Remarks: Initial response: neces			cause given	
Ac.90	Leak in Rhone river of hv	Major Accident	General chemicals manufact	Hydrogen peroxide st	A leak of 30 t of hydroge	The leak was at the H2C	The leak evidently lasted	 no description			Information available	
Ac.91	Release of hydrogen chlo	Major Accident	General chemicals manufact	Pressure increased in	Part affected:Chlorinat	The mixture of 3-chloro	Outside the operating area	Population alerted by			change. It provides:According to the new op	
Ac.92	Domino explosion and de	Major Accident	Production and storage of p	ACCIDENT CASE HIST	The accident occurred du	INITIATING EVENT AND	EFFECTS ON PEOPLE:The	n INTERNAL TO THE EST			cause given	
Ac.93	Hydrogen chloride escap	Major Accident	General chemicals manufact	ACCIDENT CASE HIST	The accident occurred du	CAUSES:An operator, de	MATERIAL LOSS:A venting	INTERNAL TO THE EST			Measures TO PREVENT ANY RECURRING I	
Ac.94	Release of biogas and fer	Major Accident	Power generation, supply an	On 10 June 2016 a fo	Part affected:Gas accum	As far as is currently kn	Material damage to the ga	All substrate and gas			arrangements were agreed and 100000	
Ac.95	Explosion in the cracking	Major Accident	Petrochemical / Oil Refiner	ACCIDENT CASE HIST	The accident occurred du	INITIATING EVENT AND	EFFECTS ON PEOPLE:4 peo	n INTERNAL TO THE EST			cause given	
Ac.96	Explosion and fire of the	Major Accident	Petrochemical / Oil Refiner	The initial gravity of	It occurred in Unit G of	Leakage of distilled pet	Loss of materials in the aff	On-site: emergency stu			location of dynamic forward command post	
Ac.97	Accident during the produ	Major Accident	General chemicals manufact	ACCIDENT CASE HIST	The component involve	CAUSES:Due to a huma	Ecological harm -	Remarks: INTERNAL TO THE EST			Measures to prevent recurrence: After the an	
Ac.98	Release of hydrogen chlo	Major Accident	General chemicals manufact	30 litres of water we	Reactor vessel, cooler	R) The cause of the relea	Cleaning and repair of the	The safety devices re			revision of the P&ID (based and independ	
Ac.99	Explosion in a silicon dust	Major Accident	General chemicals manufact	Explosion in a silicon	silicon dust suspension	not given	Plant section totally dest	The onsite fire brigad			extinguish the gas	
Ac.100	Flammable gases, hydro	Major Accident	Petrochemical / Oil Refiner	SYSTEM ORIGINATIN	The accident occurred du	CAUSES:The heat-exha	MATERIAL LOSSES:The re	INTERNAL TO THE EST			cause given	
Ac.101	Toxic release of chlorine	Major Accident	General chemicals manufact	ACCIDENT CASE HIST	The component involve	INITIATING EVENT AN	EFFECTS ON PEOPLE:1 ope	n INTERNAL TO THE EST			Measures to prevent recurrence: After the an	
Ac.102	Explosion occurred clean	Major Accident	Processing of metals	An explosion occurre	The acid solutions in the	Hydrogen gas may have	The explosion could be felt	Firefighters, at least			there might have been an accumulation of th	
Ac.103	Explosion at a high densit	Major Accident	Plastic and rubber manufact	 In order to cle		Causes of the release: f	Two product storage silos				 technical aspects Manual shut	
Ac.104	Release from an unload	Major Accident	General chemicals manufact	In a chemical process	The road tanker involve	The accident was cause	24 t of chemicals were rele	The on-site emergenc			The short time that has elapsed since the acc	
Ac.105	Release of methane and	Major Accident	Petrochemical / Oil Refiner	SAFETY SYSTEMS OR	The failure occurred in a	INITIATING EVENT AN	MATERIAL LOSS:The explo	n INTERNAL TO THE EST			Measures to prevent recurrence: The plant ha	
Ac.106	During maintenance an	Major Accident	Building & works of engine	Since several weeks,	The installations concern	management fault: the	Apart from the two metall	no information is give			Measures to prevent recurrence: The urgent	
Ac.107	Release of hydrogen and	Near Miss	Plastic and rubber manufact	While deplugging a c	Cooling system in polyim	De-blocking of a cooler	One employee standing ne	Sprinkler systems were			conditions as operating procedures should not	
Ac.108	Hydrogen explosion in a	Major Accident	General chemicals manufact	In the electrical netw	 Hydrogen high pr	Human failure during re	2 people injured and hos	The measurement and			the building of the compressor store has tak	
Ac.109	Chlorine release due to	Major Accident	General chemicals manufact	During chlor-alkali ele	The initiating event was	Technical error, equipm	Three fire fighting officials	The plant was immedi			the aggregate affected was re-designed, even	
Ac.110	Explosion of a leach tank	Major Accident	General chemicals manufact	Explosion of a leach t	During maintenance wor	Since the actual cause i	Immediate effects: Human	The tank and connect			not enough knowledge about the cause	
Ac.111	Mobile vacuum tank expl	Other Event	Petrochemical / Oil Refiner	On 2 March 2012, the	AB 'ORLENE Lietuva' KT-1)	- inappropriate manipu	Two 'paslaugos tau' emplo	The competent officia			when carrying out any technological proc	
Ac.112	Release of hydrogen sulph	Major Accident	Waste storage, treatment	Release of hydrogen	On this occasion a roa	There was insufficient	1 employee was killed; he	Attendance by Fire/PC			adequate assessment procedures are essent	
Ac.113	Explosion and fire of mkt	Major Accident	General chemicals manufact	Tube burst in furnace	Preheating furnace for	High temperature sulph	One operator was at work	First objective of the			Measures to prevent recurrence: Adequat	
Ac.114	Fire with release of subst	Major Accident	Ceramics (bricks, pottery, gl	Fire with release of s	hazardous substances st	The analysis of the phys	Material damage onsite: m	Safety function): 			Measures to prevent recurrence: The plant ha	
Ac.115	Abnormal level of molten	Major Accident	Processing of metals	Abnormal level of mo	Electric steel furnace wil	Cause of abnormal leve	10 employees slightly injur	As soon as the noise			alarm applications required under 1706 Act	
Ac.116	Release from oil storage	Major Accident	Fuel storage (including heat	At 8:15 hrs the bott	Tank with a capacity of 1	At 8:15 hrs the bottom	2000 m3 of crude oil spill	The operator activate			minor leakage was detected 10 day later	
Ac.117	Leakage of carbon mono	Major Accident	Chemical installations - am	During start-up opera	The accident took place	The reasons for gas rele	One contractor worker die	There were measure			In order to prevent such accidents in the fut	
Ac.118	Explosion of a reactor	Major Accident	General chemicals manufact	ACCIDENT CASE HIST	The accident occurred in	CAUSES:The investigat	OTHER:The effects of the	Emergency measures			Measures to prevent recurrence: After the ac	
Ac.119	Fire at refinery following	Major Accident	Petrochemical / Oil Refiner	At around 3:45 p.m.	The facility affected is	The accident is presume	The facility suffered such	At 3:40 p.m. a worker			After the accident, the operator provided the	
Ac.120	Explosion and fire on the	Major Accident	Petrochemical / Oil Refiner	Shortly after 6pm, on	The amine regeneration	 Lack of knowledge	Explosion incident	An explo			The fire was brought	

Appendix D: Expert questionnaire (Round one)

Please list at list which is the most dangerous spaces (DS) related to the use of HFC on board ship. Or in other words, what are the most critical areas that must be under more attention to avoid any significant risks from happening?

DS 1.....

DS 2.....

DS 3.....

DS 4.....

DS 5.....

DS 6.....

Others.....

Please rank the above DS's in the order of decreasing importance (1- most dangerous, 6- least essential).

Dangerous spaces(DS) on board HFC ships	Rank (1-6)
DS 1	
DS 2	
DS 3	
DS 4	
DS 5	
DS 6	
Others	

Appendix E. Expert questionnaire (Round two)

Hazardous event Questionnaire for HFC ships		
Please fill in the Hazardous event that may occur on HFC ships and the reasons for them based on your own work experience. Rank them from 1 to 4 (1.Extremely Remote, 2.Remote, 3.reasonably probable, 4.Frequent)		
Hazardous events	Causes	Probability of event (1-4),including all possible causes