

**UCC Library and UCC researchers have made this item openly available.  
 Please [let us know](#) how this has helped you. Thanks!**

|                                    |                                                                                                                                                                                                                                                                                                                                                 |
|------------------------------------|-------------------------------------------------------------------------------------------------------------------------------------------------------------------------------------------------------------------------------------------------------------------------------------------------------------------------------------------------|
| <b>Title</b>                       | Flow injection chemiluminescence determination of isoniazid using luminol and silver nanoparticles                                                                                                                                                                                                                                              |
| <b>Author(s)</b>                   | Haghighi, Behzad; Bozorgzadeh, Somayyeh                                                                                                                                                                                                                                                                                                         |
| <b>Publication date</b>            | 2010-12-01                                                                                                                                                                                                                                                                                                                                      |
| <b>Original citation</b>           | Haghighi, B. and Bozorgzadeh, S. (2010) 'Flow injection chemiluminescence determination of isoniazid using luminol and silver nanoparticles', <i>Microchemical Journal</i> , 95 (2), pp. 192-197. doi: 10.1016/j.microc.2009.11.012                                                                                                             |
| <b>Type of publication</b>         | Article (peer-reviewed)                                                                                                                                                                                                                                                                                                                         |
| <b>Link to publisher's version</b> | <a href="https://doi.org/10.1016/j.microc.2009.11.012">https://doi.org/10.1016/j.microc.2009.11.012</a><br><a href="http://dx.doi.org/10.1016/j.microc.2009.11.012">http://dx.doi.org/10.1016/j.microc.2009.11.012</a><br>Access to the full text of the published version may require a subscription.                                          |
| <b>Rights</b>                      | © 2010 Elsevier B. V. This manuscript version is made available under the CC-BY-NC-ND 4.0 license<br><a href="https://creativecommons.org/licenses/by-nc-nd/4.0/">https://creativecommons.org/licenses/by-nc-nd/4.0/</a><br><a href="https://creativecommons.org/licenses/by-nc-nd/4.0/">https://creativecommons.org/licenses/by-nc-nd/4.0/</a> |
| <b>Item downloaded from</b>        | <a href="http://hdl.handle.net/10468/13519">http://hdl.handle.net/10468/13519</a>                                                                                                                                                                                                                                                               |

Downloaded on 2022-12-08T09:09:12Z

## Accepted Manuscript

Flow injection chemiluminescence determination of isoniazid using luminol and silver nanoparticles

Behzad Haghghi, Somayyeh Bozorgzadeh

PII: S0026-265X(09)00200-8  
DOI: doi: [10.1016/j.microc.2009.11.012](https://doi.org/10.1016/j.microc.2009.11.012)  
Reference: MICROC 1137

To appear in: *Microchemical Journal*

Received date: 29 September 2009  
Revised date: 23 November 2009  
Accepted date: 23 November 2009



Please cite this article as: Behzad Haghghi, Somayyeh Bozorgzadeh, Flow injection chemiluminescence determination of isoniazid using luminol and silver nanoparticles, *Microchemical Journal* (2009), doi: [10.1016/j.microc.2009.11.012](https://doi.org/10.1016/j.microc.2009.11.012)

This is a PDF file of an unedited manuscript that has been accepted for publication. As a service to our customers we are providing this early version of the manuscript. The manuscript will undergo copyediting, typesetting, and review of the resulting proof before it is published in its final form. Please note that during the production process errors may be discovered which could affect the content, and all legal disclaimers that apply to the journal pertain.

## Flow injection chemiluminescence determination of isoniazid using luminol and silver nanoparticles

Behzad Haghighi \*, Somayyeh Bozorgzadeh

*College of Chemistry, Institute for Advanced Studies in Basic Sciences, Zanjan, Iran, 45195-1159*

### ABSTRACT

The effect of silver colloidal nanoparticles (AgNPs) on the luminol-isoniazid system was investigated. It was found that AgNPs could act as a nanocatalyst on the luminol-isoniazid system to generate chemiluminescence (CL). The CL emission spectrum of the luminol-isoniazid-AgNPs system showed a peak with a maximum at 425 nm. It was suggested that the luminophor species was the excited state 3-aminophthalate. The reduction of dissolved  $O_2$  to  $H_2O_2$  by isoniazid and decomposition of  $H_2O_2$  to the oxygen-related radicals were attributed to the catalytic effect of AgNPs. Under optimized conditions, the CL signal intensity was linear with the isoniazid concentration in the range of  $10-1000 \text{ ng mL}^{-1}$ , with the correlation coefficient of 0.9996. The limit of detection was  $2.7 \text{ ng mL}^{-1}$  isoniazid. The relative standard deviations for seven repeated measurements of  $60$  and  $200 \text{ ng mL}^{-1}$  isoniazid were 1.4 and 2.4%, respectively. The effect of potent interfering compounds on the CL signal intensity of the proposed luminol-isoniazid-AgNPs system was investigated. The proposed method was successfully applied to the determination of isoniazid in a pharmaceutical sample.

*Keywords:* Chemiluminescence; Isoniazid; Silver nanoparticle; Luminol; Flow injection analysis.

---

\* Corresponding author. Tel: +98 241 4153 126, Fax: +98 2414153 232  
E-mail address: [haghighi@iasbs.ac.ir](mailto:haghighi@iasbs.ac.ir) (B. Haghighi)

## 1. Introduction

Isoniazid (pyridine-4-carboxylic acid hydrazide or isonicotinic acid hydrazide (INH)) is an important bacteriostatic drug in the treatment of tuberculosis caused by mycobacteria. Currently, there are 8 million new patients per year receiving treatment with isoniazid, which is the safest and most cost-effective treatment for tuberculosis. Owing to its therapeutic importance and widespread use, considerable attention has been paid to develop sensitive and rapid analytical techniques for the determination of isoniazid either in pure form, in pharmaceutical preparations or in biological fluids. Among the various analytical methods which have been reported for the analysis of isoniazid, those methods based on titrimetry [1], spectrophotometry [2-6], electrochemistry [7-13], spectrofluorometry [14-16], high performance liquid chromatography [14, 17-19], capillary electrophoresis [20], electrochemiluminescence (ECL) [21] and chemiluminescence (CL) [22-25] are the most cited.

Chemiluminescence is an attractive detection means for trace analysis due to some features that make it superior to the other detection principles especially to those involving light (mainly absorption spectroscopy and fluorometry). The most common cited advantages of CL reactions are: sufficiently low limit of detection, excellent sensitivity, wide dynamic range, simple instrumentation and suitable for automation. Common strategies which have been used for the CL detection of isoniazid are either based on direct oxidation of isoniazid by various oxidants such as *N*-bromosuccinimide (NBS) [26],  $K_3Fe(CN)_6$  [27] and  $KIO_4$  [28] or based on inhibition or enhancement effect of isoniazid on other CL systems such as inhibition effect on the luminol- $H_2O_2$ - $K_3Fe(CN)_6$  system [29], or enhancement effect on the luminol-NBS (or *N*-chlorosuccinimide (NCS)) [30], lucigenin-periodate [24] and  $Ru(phen)_3^{2+}$ -Ce(IV) systems [23].

In recent years, many attentions have been paid to use metal nanoparticles (NPs) as nanocatalysts in CL reactions [31-43], because of their unique physical and chemical properties and great analytical potential. Cui et al. found that the gold [37], platinum [35] and silver [39] NPs could catalyze and enhance luminol-H<sub>2</sub>O<sub>2</sub> CL reaction. They also found AgNPs exhibited a better CL catalytic ability than gold and platinum NPs. Silver can be oxidized by H<sub>2</sub>O<sub>2</sub>, producing hydroxyl radicals, more easier than gold, since its oxidation potential is lower than that of gold [44].

In this work, the effect of AgNPs on the luminol-isoniazid system was investigated. It was found that AgNPs could act as a nanocatalyst on the luminol-isoniazid system to generate CL. Based on the catalytic effect of AgNPs a new, rapid, simple, sensitive and inexpensive method was proposed for the determination of isoniazid without using any oxidant. The effect of reaction conditions on the CL signal intensity was explored in the flow injection (FI) mode of analysis. Under the optimized conditions, the proposed FI-CL system was applied for the determination of isoniazid in a pharmaceutical sample. Also, a possible reaction mechanism for the proposed luminol-isoniazid-AgNPs CL system was discussed briefly.

## **2. Experimental**

### *2.1. Materials*

Analytical reagent-grade chemicals were used without further purification. Isoniazid, trisodium citrate dehydrate, calcium sulfate and magnesium sulfate were obtained from Fluka (Buchs, Switzerland). Sodium hydroxide, ascorbic acid, luminol, riboflavin, glutamic acid, sodium borohydride, silver nitrate, starch soluble, citric acid were obtained from Merck (Schuchardt, Germany). Thiamine hydrochloride was purchased from Sigma-Aldrich (Steinheim, Germany).

A  $1.0 \times 10^{-2}$  M stock solution of luminol (3-aminophthalhydrazide) was prepared by dissolving luminol in 0.1 M NaOH. Working solutions of luminol were prepared by diluting the stock solution with appropriate amounts of NaOH solution. Stock solution of isoniazid ( $1000 \mu\text{g mL}^{-1}$ ) was prepared by dissolving appropriate amount of isoniazid in water and stored at  $4 \text{ }^\circ\text{C}$  in the refrigerator. Working standard solutions of isoniazid were freshly prepared from the stock solution. Triply distilled water was used for preparing all other solutions and diluting them.

Colloidal solution of AgNPs was prepared according to the method reported previously [39] without modification. In brief, 25 mL aqueous  $\text{AgNO}_3$  solution ( $1 \times 10^{-3}$  M) was added dropwise to 75 mL freshly prepared aqueous  $\text{NaBH}_4$  solution ( $2 \times 10^{-3}$  M) with vigorous stirring. After 10 minutes, 5 mL aqueous sodium citrate solution (1% w/w) was added to the resultant solution to stabilize the AgNPs. Yellow colloidal solution of AgNPs was stirred for another 20 min and aged for 2 days at  $4 \text{ }^\circ\text{C}$  before use.

## 2.2. Apparatus

Figure 1 shows the schematic diagram of the flow injection chemiluminescence (FI-CL) system used for the determination of isoniazid. A Watson Marlow 505Du peristaltic pump propelled carrier stream of water, reagent and isoniazid solutions using silicon manifold tubing (0.76 mm i.d.). The flow lines were made from Supelco Teflon tubing (0.5 mm i.d.). The colloidal solution of AgNPs was injected via a Rheodyne six-way Teflon rotary valve type 50 into the water stream. The CL signal intensity was measured using a Varian Cary Eclipse fluorescence spectrophotometer equipped with a home-made CL flow-through cell [45]. The body of the CL flow cell was made from a block of Plexi-glass. Grooves were machined on the surface of the cell body to make inlet and outlet channels on the surface. A piece of transparent glass window was

mounted on the surface of the cell body and then was tightened by a holder. The outlet channel, where the chemiluminescence reaction occurred and the emitted light passed through the transparent glass window, was a groove with a depth, width and length of 1, 1 and 200 mm, respectively. The CL signal intensity was collected at 0.1 s intervals using Cary Eclipse Bio software. The absorption spectrum was recorded using a single beam Pharmacia UV/Vis spectrophotometer (Ultrospec, model 4000). Scanning electron microscopy (SEM) was performed with a Philips instruments, Model X-30. All measurements were performed at the room temperature.

### 2.3. General procedure

The carrier streams of water, isoniazid ( $500 \text{ ng mL}^{-1}$ ) and luminol ( $0.3 \text{ mM}$  in  $0.083 \text{ M NaOH}$ ) were propelled into the flow lines with the flow rate of  $0.55 \text{ mL min}^{-1}$ , as shown in Fig. 1. A colloidal solution of AgNPs ( $220 \text{ }\mu\text{L}$  of as prepared colloidal solution) was injected at I into the water stream. The carrier stream of water containing AgNPs zone merged with the stream of analyte (isoniazid) at the three-way connector T and mixed through the mixing coil C ( $0.5 \text{ mm i.d}$  and  $20 \text{ cm}$ ). The resultant mixture then mixed and reacted with the reagent stream of luminol in the home-made CL flow-through cell, which had positioned in front of the detector window of a Varian Cary Eclipse fluorescence spectrophotometer. The CL signal intensity of the luminol-isoniazid-AgNPs system was recorded at  $425 \text{ nm}$ .

### 2.4. Sample preparation

20 isoniazid tablets ((Daru-Pakhsh, Iran) were weighted and ground to fine powder in a mortar and then mixed. A portion of powder equivalent to the approximately  $100 \text{ mg}$  isoniazid was weighed accurately, transferred into  $100 \text{ mL}$  volumetric flask and dispersed in triply distilled water. The mixture was sonicated for  $20 \text{ min}$  to aid its

dissolution and then made up to volume with water. The resultant solution was then filtered. An appropriate volume of the filtrate was diluted further with water so that the concentration of isoniazid in the final sample solution was within the working range.

### 3. Results and Discussion

Figure 2 shows the scanning electron microscopy (SEM) image of the prepared AgNPs. The analysis of SEM images revealed that the average diameter of AgNPs was about 70 nm.

The CL emission spectrum of the luminol-isoniazid system was recorded in the absence and presence of AgNPs in the flow mode by continuous propelling of colloidal AgNPs solution into the system. As shown in Fig. 3, no CL emission observed for the luminol-isoniazid system but in the presence of AgNPs, the CL spectrum showed a peak with a maximum at 425 nm. Also, preliminary studies showed that the CL signal intensity of the luminol-isoniazid-AgNPs system increased with increasing the concentration of isoniazid. So, a wavelength of 425 nm was selected and using univariate optimization method, the influence of the chemical and hydrodynamic parameters on the CL signal intensity of the luminol-isoniazid-AgNPs system was studied in the flow injection mode of analysis.

#### 3.1. Optimization of the FI-CL system

The effect of chemical parameters including concentrations of luminol, NaOH, and AgNPs on the CL signal intensity of the luminol-isoniazid-AgNPs system was investigated. As shown in Fig. 4a, at the fixed concentrations of NaOH (0.05 M) and AgNPs (220  $\mu$ L of as prepared colloidal solution) increasing the concentration of luminol from 0 to 0.3 mM caused a sharp increase in the CL signal intensity. Further



increase in luminol concentration (up to 1 mM) caused a decline in the CL signal. So, 0.3 mM luminol was selected as the optimal concentration for the further experiments.

Investigation on the effect of NaOH concentration from 0 to 0.4 M on the CL signal intensity was performed at the fixed concentrations of luminol (0.3 mM) and AgNPs (220  $\mu$ L of as prepared colloidal solution). As shown in Fig. 4b, the CL intensity increased with increasing the concentration of NaOH and reached a maximum at about 0.083 M NaOH, then decreased. That might be due to the fact that the catalytic ability of AgNPs declined in the high alkaline media. Thus, 0.083 M was selected as the optimal concentration of NaOH for the further experiments.

The concentration of AgNPs could affect on the CL intensity of the luminol-isoniazid-AgNPs system (Fig. 4c). At the fixed concentration of luminol (0.3 mM) and NaOH (0.083 M), the CL signal intensity increased linearly with the concentration of AgNPs solution. The as prepared colloidal solution of AgNPs (0.238 mM, based on the concentration of silver nitrate solution used for the preparation of AgNPs) was used for the subsequent works.

The influence of the carrier flow rate (0.1 to 1.3 mL min<sup>-1</sup>) on the CL signal intensity of the luminol-isoniazid-AgNPs system was also investigated at the concentrations found optimal for the chemical parameters. The CL intensity increased with increasing of the carrier flow rate and reached a maximum at about 0.55 mL min<sup>-1</sup>, then decreased (Fig. 4d). A flow rate of 0.55 mL min<sup>-1</sup> was therefore selected for the further studies.

### 3.2. Analytical characteristics of the FI-CL system

Calibration trace for isoniazid recorded using the proposed FI-CL system and a series of standard isoniazid solutions under conditions found optimal. Calibration curve for isoniazid was linear over 10 - 1000 ng mL<sup>-1</sup> with the correlation coefficient of

0.9996. The limit of detection (signal to noise ratio = 3) was  $2.7 \text{ ng mL}^{-1}$  isoniazid. The relative standard deviations (RSD) for repetitive measurements ( $n=7$ ) of 60 and  $200 \text{ ng mL}^{-1}$  isoniazid were 1.4 and 2.4%, respectively. Figure 5 shows typical calibration traces recorded for isoniazid using the proposed CL system.

### 3.3. Interference study

The effect of common excipients used in pharmaceutical preparations of isoniazid and also common co-existing compounds were tested as potent interferents. A series of solutions containing  $0.5 \text{ } \mu\text{g mL}^{-1}$  of isoniazid plus various amounts of potent interfering compounds were prepared. The CL signals of the prepared solutions were recorded and compared with that obtained for the standard isoniazid solution ( $0.5 \text{ } \mu\text{g mL}^{-1}$ ). A 5% error criterion was adopted. There was no interference from glucose and starch at the concentration about  $125 \text{ } \mu\text{g mL}^{-1}$  (250 fold, maximum ratio studied). Citric acid, calcium sulfate and magnesium sulfate at the concentrations more than 25 (50 fold), 10 (20 fold) and 1 (2 fold)  $\mu\text{g mL}^{-1}$  decreased the CL signal intensity, respectively. Thiamine hydrochloride (vitamin B1) and ascorbic acid (vitamin C), two common vitamins, at the concentration about  $0.5 \text{ } \mu\text{g mL}^{-1}$  decreased the CL signal intensity. Riboflavin (vitamin B2) at the concentrations more than  $25 \text{ } \mu\text{g mL}^{-1}$  increased the CL signal. Glutamic acid, a common amino acid, at the concentrations more than  $25 \text{ } \mu\text{g mL}^{-1}$  (50 fold) decreased the CL signal intensity.

### 3.4. Real sample analysis

The proposed FI-CL system was successfully applied to the determination of isoniazid in isoniazid tablets. To examine the reliability of the method certain amounts of standard isoniazid solution was added to the sample solutions and analyzed according

to the proposed method. Recovery of each measurement was calculated by comparing the results obtained before and after adding of standard isoniazid solution. The results have been listed in Table 1.

### 3.5. Possible mechanism of the CL system

The reduction of dissolved oxygen to hydrogen peroxide by isoniazid in alkaline media has been proposed in the previous CL studies [22, 25, 30, 46-50]. Safavi et al. proposed that the gold nanoparticles could catalyze the reduction of  $O_2$  to  $H_2O_2$  by  $N_2H_4$  [51]. In 1977 Ono et al. proposed a mechanism in which  $H_2O_2$  was decomposed to  $OH^\bullet$  on the surface of metal catalyst and then the reaction between  $OH^\bullet$  and  $H_2O_2$  or  $HO_2^-$  led to generate superoxide anion [52]. Recently, it was proposed that the oxygen-oxygen bond of  $H_2O_2$  was rapidly broken to give  $OH^\bullet$  radicals by the catalytic action of gold [37], Ag [39] and Pt [35] nanoparticles. The generated hydroxyl radicals were stabilized at the surface of nanoparticles via partial electron exchange interactions [53]. The subsequent reactions of  $OH^\bullet$  radicals with luminol anion and  $HO_2^-$  facilitated the formation of luminol radical ( $L^{\bullet-}$ ) and superoxide radical ( $O_2^{\bullet-}$ ) anions [54]. Further reaction between  $L^{\bullet-}$  and  $O_2^{\bullet-}$  produced the excited-state 3-aminophthalate anion which was the emitter (luminophor) in the luminol- $H_2O_2$  CL reaction system with a maximum CL emission at 425 nm [54, 55].

In this study no detectable CL emission was recorded for the luminol-isoniazid system in the absence of AgNPs. The presence of  $AgNO_3$ , citrate,  $AgNO_3$ -citrate and  $NaBH_4$ -citrate, the reagents used for the preparation of AgNPs, had no effect on the luminol-isoniazid system. But, a strong CL signal was recorded when AgNPs was injected into the luminol-isoniazid system. Therefore, the CL emission was attributed to the catalytic effect of the AgNPs on the luminol-isoniazid system.

The CL emission spectrum of the luminol-isoniazid-AgNPs system showed a peak with maximum at 425 nm, suggesting the possible formation of the excited state 3-aminophthalate ion as the luminophor in the course of the CL reaction similar to those reported previously for the luminol oxidation [55].

The working solutions of luminol, isoniazid and AgNPs, were saturated with O<sub>2</sub> and N<sub>2</sub> by bobbling and then the system of luminol-isoniazid-AgNPs was examined under saturated conditions. The intensity of the recorded CL signals for saturated and normal conditions increased in the order N<sub>2</sub> saturated < normal < O<sub>2</sub> saturated, suggesting the participation of O<sub>2</sub> in the course of the CL reaction.

The CL signal intensity of the luminol-isoniazid-AgNPs system was strongly quenched by ascorbic acid. Ascorbic acid can act as a superoxide radical anion scavenger [56, 57] giving, though, the production of superoxide radical anion in the course of the CL reaction.

So, on the basis of the previously reported results and the results obtained in this study, it is proposed that isoniazid reduces dissolved oxygen to hydrogen peroxide by catalytic action of AgNPs. Then, H<sub>2</sub>O<sub>2</sub> is rapidly decomposed to OH• radicals at the surface of AgNPs. The subsequent reactions of OH• radicals with luminol anion and HO<sub>2</sub><sup>-</sup> produce luminol radical (L•<sup>-</sup>) and superoxide radical (O<sub>2</sub>•<sup>-</sup>) anions. The reaction of L•<sup>-</sup> and O<sub>2</sub>•<sup>-</sup> produces the excited state 3-aminophthalate anion which emits the CL emission at 425 nm. Scheme 1 shows the proposed CL reaction mechanism for the luminol-isoniazid-AgNPs system.

#### 4. Conclusions

It was found that AgNPs could act as a nanocatalyst on the luminol-isoniazid system to generate CL. The luminophor of the luminol-isoniazid-AgNPs CL system was identified as the excited state 3-aminophthalate anion. It was suggested that the

chemiluminescence of the luminol-isoniazid-AgNPs system was due to catalytic ability of AgNPs on the reduction of dissolved  $O_2$  to  $H_2O_2$  by isoniazid in addition to its catalytic effect on the decomposition of  $H_2O_2$  to hydroxyl radical. The proposed CL system was successfully applied to the determination of isoniazid in a pharmaceutical sample.

### **Acknowledgement**

The authors gratefully acknowledge support by the Institute for Advanced Studies in Basic Sciences (IASBS) Research Council under grant number G2009IASBS119.

**References:**

- [1] A.M. Elbrashy, S.M. Elashry, Colorimetric and titrimetric assay of isoniazid, *J. Pharmaceut. Biomed.* 10 (1992) 421-426.
- [2] P. Nagaraja, K.C.S. Murthy, H.S. Yathirajan, Spectrophotometric determination of isoniazid with sodium 1,2-naphthoquinone-4-sulphotlate and cetyltrimethyl ammonium bromide, *Talanta* 43 (1996) 1075-1080.
- [3] P. Nagaraja, K.C.S. Murthy, K.S. Rangappa, N.M.M. Gowda, Spectrophotometric methods for the determination of certain catecholamine derivatives in pharmaceutical preparations, *Talanta* 46 (1998) 39-44.
- [4] S.A. Benetton, E.R.M. Kedor-Hackmann, M. Santoro, V.M. Borges, Visible spectrophotometric and first-derivative UV spectrophotometric determination of rifampicin and isoniazid in pharmaceutical preparations, *Talanta* 47 (1998) 639-643.
- [5] H.C. Goicoechea, A.C. Olivieri, Simultaneous determination of rifampicin, isoniazid and pyrazinamide in tablet preparations by multivariate spectrophotometric calibration, *J. Pharmaceut. Biomed.* 20 (1999) 681-686.
- [6] G.K. Naidu, K. Suvadhan, K.S. Kumar, D. Rekha, B.S. Sastry, P. Chiranjeevi, Simple sensitive spectrophotometric determination of isoniazid and ritodrine hydrochloride, *Anal. Chem.* 60 (2005) 822-827.
- [7] B.C. Channu, H.N. Kalpana, L. Ramesh, C. Dass, G.B. Eregowda, K.N. Thimmaiah, Spectral and cyclic voltammetric investigation of oxidized products of 10-4'-(N-diethylamino)butyl-2-chlorophenoxazine and its applications in redox titrimetry, *Mikrochim. Acta* 134 (2000) 125-132.
- [8] J. Tong, X.J. Dang, H.L. Li, Electrochemical oxidation of isoniazid catalyzed by the 2,2,6,6-tetramethyl-4-acetylpiperidine-1-oxy radical and its analytical application, *Electroanalysis* 9 (1997) 165-168.

- [9] E. Hammam, A.M. Beltagi, M.M. Ghoneim, Voltammetric assay of rifampicin and isoniazid drugs, separately and combined in bulk, pharmaceutical formulations and human serum at a carbon paste electrode, *Microchem. J.* 77 (2004) 53-62.
- [10] H.Y. Xia, X.Y. Hu, Determination of isoniazid using a gold electrode by differential pulse voltammetry, *Anal. Lett.* 38 (2005) 1405-1414.
- [11] Z.N. Gao, X.X. Han, H.Q. Yao, B. Liang, W.Y. Liu, Electrochemical oxidation of isoniazid catalyzed by (FcM)TMA at the platinum electrode and its practical analytical application, *Anal. Bioanal. Chem.* 385 (2006) 1324-1329.
- [12] M.S.M. Quintino, L. Angnes, Fast BIA-amperometric determination of isoniazid in tablets, *J. Pharmaceut. Biomed.* 42 (2006) 400-404.
- [13] G.J. Yang, C.X. Wang, R. Zhang, C.Y. Wang, Q.S. Qu, X.Y. Hu, Poly(amidosulfonic acid) modified glassy carbon electrode for determination of isoniazid in pharmaceuticals, *Bioelectrochemistry* 73 (2008) 37-42.
- [14] H. Kubo, T. Kinoshita, K. Matsumoto, T. Nishikawa, Fluorometric-determination of isoniazid and its metabolites in urine by high-performance liquid-chromatography, *Chromatographia* 30 (1990) 69-72.
- [15] R.J. Garcavillanova, R.M.G. Estepa, Fluorometric-determination of diacetyl and 2,3-pentanedione with isoniazid and a zirconium salt, *Talanta* 40 (1993) 1419-1423.
- [16] R.A.S. Lapa, J. Lima, J.L.M. Santos, Fluorimetric determination of isoniazid by oxidation with cerium (IV) in a multicommutated flow system, *Anal. Chim. Acta* 419 (2000) 17-23.
- [17] E. Sottofattori, R. Raggio, O. Bruno, Milk as a drug analysis medium: HPLC determination of isoniazid, *J. Chem. Educ.* 80 (2003) 547-549.

- [18] W.P. Yang, Y.T. Zhang, Z.J. Zhang, Determination of isoniazid and rifampin by high performance liquid chromatography with chemiluminescent detection, *Acta Chim. Sinica* 61 (2003) 303-306.
- [19] H.I. Seifart, W.L. Gent, D.P. Parkin, P.P. vanJaarsveld, P.R. Donald, High-performance liquid chromatographic determination of isoniazid, acetylisoniazid and hydrazine in biological fluids, *J. Chromatogr. B* 674 (1995) 269-275.
- [20] E. Nemutlu, M. Celebier, B. Uyar, S. Altinoz, Validation of a rapid micellar electrokinetic capillary chromatographic method for the simultaneous determination of isoniazid and pyridoxine hydrochloride in pharmaceutical formulation, *J. Chromatogr. B* 854 (2007) 35-42.
- [21] X.W. Zheng, Z.H. Guo, Z.J. Zhang, Flow-injection electrogenerated chemiluminescence determination of isoniazid using luminol, *Anal. Sci.* 17 (2001) 1095-1099.
- [22] J.C. Huang, C.X. Zhang, Z.J. Zhang, Flow injection chemiluminescence determination of isoniazid with electrogenerated hypochlorite, *Fresen. J. Anal. Chem.* 363 (1999) 126-128.
- [23] X. Juan, B. Shi, X.P. Ai, Z.K. He, Chemiluminescence detection of isoniazid using  $\text{Ru}(\text{phen})_3^{2+}$ -isoniazid-Ce(IV) system, *J. Pharmaceut. Biomed.* 36 (2004) 237-241.
- [24] J.X. Du, J. Lu, Flow injection chemiluminescence determination of isoniazid using the lucigenin-periodate system, *Luminescence* 21 (2006) 26-30.
- [25] J.X. Du, J.R. Lu, Hydrazine-induced post-chemiluminescence phenomenon of permanganate-luminol reaction and its applications, *Luminescence* 19 (2004) 328-332.



- [26] S.A. Halvatzis, M.M. Timotheopotamia, A.C. Calokerinos, Continuous-flow chemiluminescence determination of isoniazid by oxidation with N-bromosuccinimide, *Analyst* 115 (1990) 1229-1234.
- [27] Y.M. Huang, Z.J. Zhang, Flow injection chemiluminescent analysis of isoniazid by direct hexacyanoferrate(III) oxidation, *Anal. Lett.* 34 (2001) 1703-1710.
- [28] B.X. Li, Z.J. Zhang, W. Liu, Flow-injection system for automated dissolution testing of isoniazid tablets with chemiluminescence detection, *Talanta* 54 (2001) 697-702.
- [29] A.G. Alapont, E.A. Gimenez, L.L. Zamora, J.M. Calatayud, Inhibition of the system luminol-H<sub>2</sub>O<sub>2</sub>-Fe(CN)<sub>6</sub><sup>3-</sup> chemiluminescence by the Mn (II) indirect determination of isoniazid in a pharmaceutical formulation, *J. Biolumin. Chemilumin.* 13 (1998) 131-137.
- [30] A. Safavi, M.A. Karimi, M.R.H. Nezhad, Flow injection determination of isoniazid using N-bromosuccinimide- and N-chlorosuccinimide-luminol chemiluminescence systems, *J. Pharmaceut. Biomed.* 30 (2003) 1499-1506.
- [31] C.F. Duan, Y.Q. Yu, H. Cui, Gold nanoparticle-based immunoassay by using non-stripping chemiluminescence detection, *Analyst* 133 (2008) 1250-1255.
- [32] H. Cui, J.Z. Guo, N. Li, L.J. Liu, Gold nanoparticle triggered chemiluminescence between luminol and AgNO<sub>3</sub>, *J. Phys. Chem. C* 112 (2008) 11319-11323.
- [33] Z.F. Zhang, H. Cui, M.J. Shi, Chemiluminescence accompanied by the reaction of gold nanoparticles with potassium permanganate, *Phys. Chem. Chem. Phys.* 8 (2006) 1017-1021.
- [34] W. Wang, T. Xiong, H. Cui, Fluorescence and electrochemiluminescence of luminol-reduced gold nanoparticles: photostability and platform effect, *Langmuir* 24 (2008) 2826-2833.

- [35] S.L. Xu, H. Cui, Luminol chemiluminescence catalysed by colloidal platinum nanoparticles, *Luminescence* 22 (2007) 77-87.
- [36] H. Chen, F. Gao, R. He, D.X. Cui, Chemiluminescence of luminol catalyzed by silver nanoparticles, *J. Colloid Interf. Sci.* 315 (2007) 158-163.
- [37] Z.F. Zhang, H. Cui, C.Z. Lai, L.J. Liu, Gold nanoparticle-catalyzed luminol chemiluminescence and its analytical applications, *Anal. Chem.* 77 (2005) 3324-3329.
- [38] L.R. Luo, Z.J. Zhang, L.Y. Hou, Development of a gold nanoparticles based chemiluminescence imaging assay and its application, *Anal. Chim. Acta* 584 (2007) 106-111.
- [39] J.Z. Guo, H. Cui, W. Zhou, W. Wang, Ag nanoparticle-catalyzed chemiluminescent reaction between luminol and hydrogen peroxide, *J. Photochem. Photobiol. A* 193 (2008) 89-96.
- [40] A.P. Fan, C.W. Lau, J.Z. Lu, Colloidal gold-polystyrene bead hybrid for chemiluminescent detection of sequence-specific DNA, *Analyst* 133 (2008) 219-225.
- [41] Y.X. Li, P. Yang, P. Wang, L. Wang, Development of a novel luminol chemiluminescent method catalyzed by gold nanoparticles for determination of estrogens, *Anal. Bioanal. Chem.* 387 (2007) 585-592.
- [42] J.Z. Guo, H. Cui, Lucigenin chemiluminescence induced by noble metal nanoparticles in the presence of adsorbates, *J. Phys. Chem. C* 111 (2007) 12254-12259.
- [43] L. Wang, P. Yang, Y.X. Li, H.Q. Chen, M.G. Li, F.B. Luo, A flow injection chemiluminescence method for the determination of fluoroquinolone derivative using the reaction of luminol and hydrogen peroxide catalyzed by gold nanoparticles, *Talanta* 72 (2007) 1066-1072.

- [44] Y.G. Sun, Y.N. Xia, Mechanistic study on the replacement reaction between silver nanostructures and chloroauric acid in aqueous medium, *J. Am. Chem. Soc.* 126 (2004) 3892-3901.
- [45] B. Haghghi, R. Dadashvand, Flow injection chemiluminescence analysis of phenolic compounds using the NCS-luminol system, *Anal. Bioanal. Chem.* 384 (2006) 1246-1253.
- [46] A. Safavi, M.A. Karimi, M.R.H. Nezhad, Flow-injection determination of isoniazid using sodium dichloroisocyanurate- and trichloroisocyanuric acid-luminol chemiluminescence systems, *Farmaco* 59 (2004) 481-486.
- [47] Y. Xiong, H.J. Zhou, Z.J. Zhang, D.Y. He, C. He, Flow-injection chemiluminescence sensor for determination of isoniazid in urine sample based on molecularly imprinted polymer, *Spectrochim. Acta A* 66 (2007) 341-346.
- [48] X.W. Zheng, Z.J. Zhang, Flow-injection chemiluminescence determination of isoniazid using on-line electrogenerated  $\text{BrO}^-$  as oxidant, *Analyst* 124 (1999) 763-766.
- [49] Y.M. Huang, Z.J. Zhang, D.J. Zhang, J. Lv, A flow injection chemiluminescence system for the determination of isoniazid, *Fresen. J. Anal. Chem.* 368 (2000) 429-431.
- [50] S.C. Zhang, H. Li, Flow-injection chemiluminescence sensor for the determination of isoniazid, *Anal. Chim. Acta* 444 (2001) 287-294.
- [51] A. Safavi, G. Absalan, F. Bamdad, Effect of gold nanoparticle as a novel nanocatalyst on luminol-hydrazine chemiluminescence system and its analytical application, *Anal. Chim. Acta* 610 (2008) 243-248.
- [52] Y. Ono, T. Matsumura, N. Kitajima, S. Fukuzumi, Formation of superoxide ion during decomposition of hydrogen-peroxide on supported metals, *J. Phys. Chem. C* 81 (1977) 1307-1311.

- [53] Z.Y. Zhang, A. Berg, H. Levanon, R.W. Fessenden, D. Meisel, On the interactions of free radicals with gold nanoparticles, *J. Am. Chem. Soc.* 125 (2003) 7959-7963.
- [54] G. Merenyi, J.S. Lind, Role of a peroxide intermediate in the chemiluminescence of luminol - a mechanistic study, *J. Am. Chem. Soc.* 102 (1980) 5830-5835.
- [55] E.H. White, M.M. Bursley, Chemiluminescence of luminol and related hydrazides: the light emission step, *J. Am. Chem. Soc.* 86 (1964) 941.
- [56] H.R. Griffiths, J. Lunec, Ascorbic acid in the 21<sup>st</sup> century - more than a simple antioxidant, *Environ. Toxicol. Phar.* 10 (2001) 173-182.
- [57] Y. Tsujimoto, H. Hashizume, M. Yamazaki, Superoxide radical scavenging activity of phenolic-compounds, *Int. J. Biochem. Cell B* 25 (1993) 491-494.

**Legend to figures:**

**Fig. 1.** Schematic diagram of the proposed FI-CL system for determination of isoniazid.

I; injection valve (220  $\mu\text{L}$ ), T; three way connector, C; mixing coil (0.5 mm i.d. and 20 cm). Conditions:  $R_1 = \text{H}_2\text{O}$ ,  $R_2 = \text{isoniazid}$ ,  $R_3 = \text{luminol (0.3 mM) + NaOH (0.083 M)}$ .

**Fig. 2.** SEM image of the prepared AgNPs.

**Fig. 3.** Chemiluminescence spectra of luminol-isoniazid system in the absence (broken line) and presence (solid line) of AgNPs when the reagents were propelled, continuously. Conditions:  $R_1 = \text{H}_2\text{O}$  or AgNPs (as prepared solution),  $R_2 = \text{isoniazid (500 ng mL}^{-1}\text{)}$ ,  $R_3 = \text{luminol (0.3 mM) + NaOH (0.083 M)}$ , flow rate = 0.55  $\text{mL min}^{-1}$ .

**Fig. 4.** The effect of a) luminol, b) NaOH and c) AgNPs concentrations and d) flow rate on the CL signal intensity. Conditions:  $R_1 = \text{H}_2\text{O}$ ,  $R_2 = \text{isoniazid (500 ng mL}^{-1}\text{)}$ , flow rate (for a, b and c) = 0.74  $\text{mL min}^{-1}$ , AgNPs (for a, b and d) = 220  $\mu\text{L}$  of as prepared solution,  $R_3$  (for a) = luminol + NaOH (0.05 M),  $R_3$  (for b) = luminol (0.3 mM) + NaOH,  $R_3$  (for c and d) = luminol (0.3 mM) + NaOH (0.083 M).

**Fig. 5.** Calibration traces obtained for the standard isoniazid solutions in the range of 10-100 (inset) and 100-1000  $\text{ng mL}^{-1}$  using luminol-isoniazid-AgNPs FI-CL system. Number above peaks denotes concentration of isoniazid in  $\text{ng mL}^{-1}$ . Conditions:  $R_1 = \text{H}_2\text{O}$ ,  $R_2 = \text{isoniazid}$ ,  $R_3 = \text{luminol (0.3 mM) + NaOH (0.083 M)}$ , AgNPs = 220  $\mu\text{L}$  of as prepared solution, flow rate = 0.55  $\text{mL min}^{-1}$ .

**Scheme1.** The proposed CL reaction pathway for the luminol-isoniazid-AgNPs system.

Table 1

FI-CL determination of isoniazid in isoniazid tablets.

| Sample taken<br>(ng mL <sup>-1</sup> ) | Added<br>(ng mL <sup>-1</sup> ) | Found<br>(ng mL <sup>-1</sup> ) | Recovery<br>(%) | RSD<br>(n= 3, %) |
|----------------------------------------|---------------------------------|---------------------------------|-----------------|------------------|
| 250                                    | 0                               | 253                             | 101.2           | 2.2              |
| 250                                    | 100                             | 251                             | 100.4           | 2.7              |
| 250                                    | 200                             | 252                             | 100.8           | 4.4              |
| 250                                    | 400                             | 254                             | 101.6           | 2.3              |
| 250                                    | 600                             | 244                             | 97.6            | 1.0              |
| 350                                    | 0                               | 352                             | 100.6           | 2.0              |
| 350                                    | 100                             | 352                             | 100.6           | 1.0              |
| 350                                    | 200                             | 349                             | 99.7            | 2.9              |
| 350                                    | 400                             | 340                             | 97.0            | 3.4              |
| 350                                    | 600                             | 352                             | 100.6           | 4.1              |

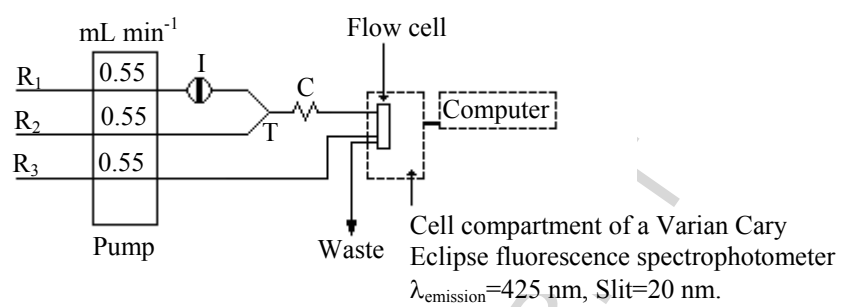
**Fig. 1**

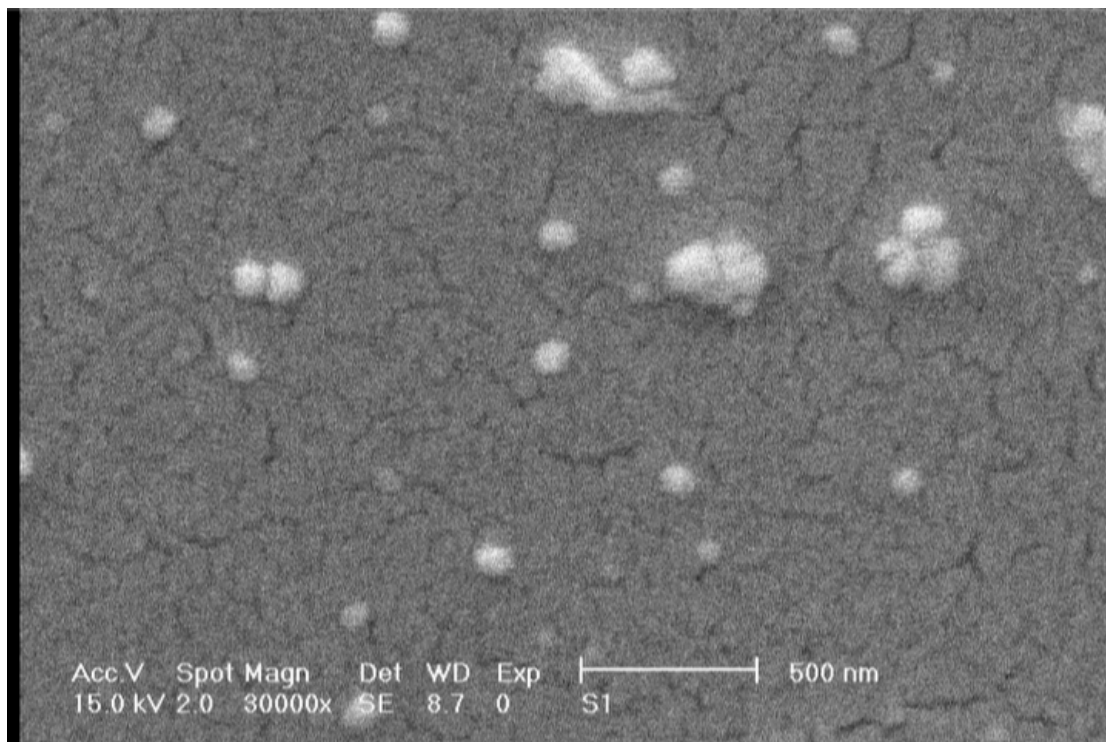
**Fig .2**

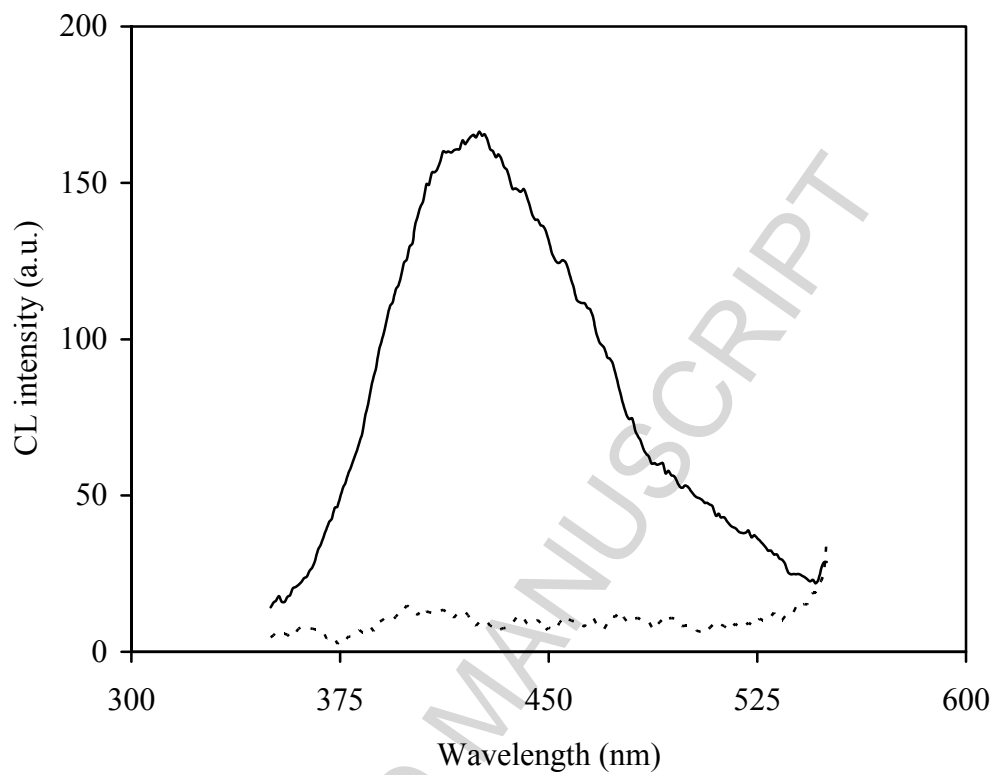

**Fig .3**

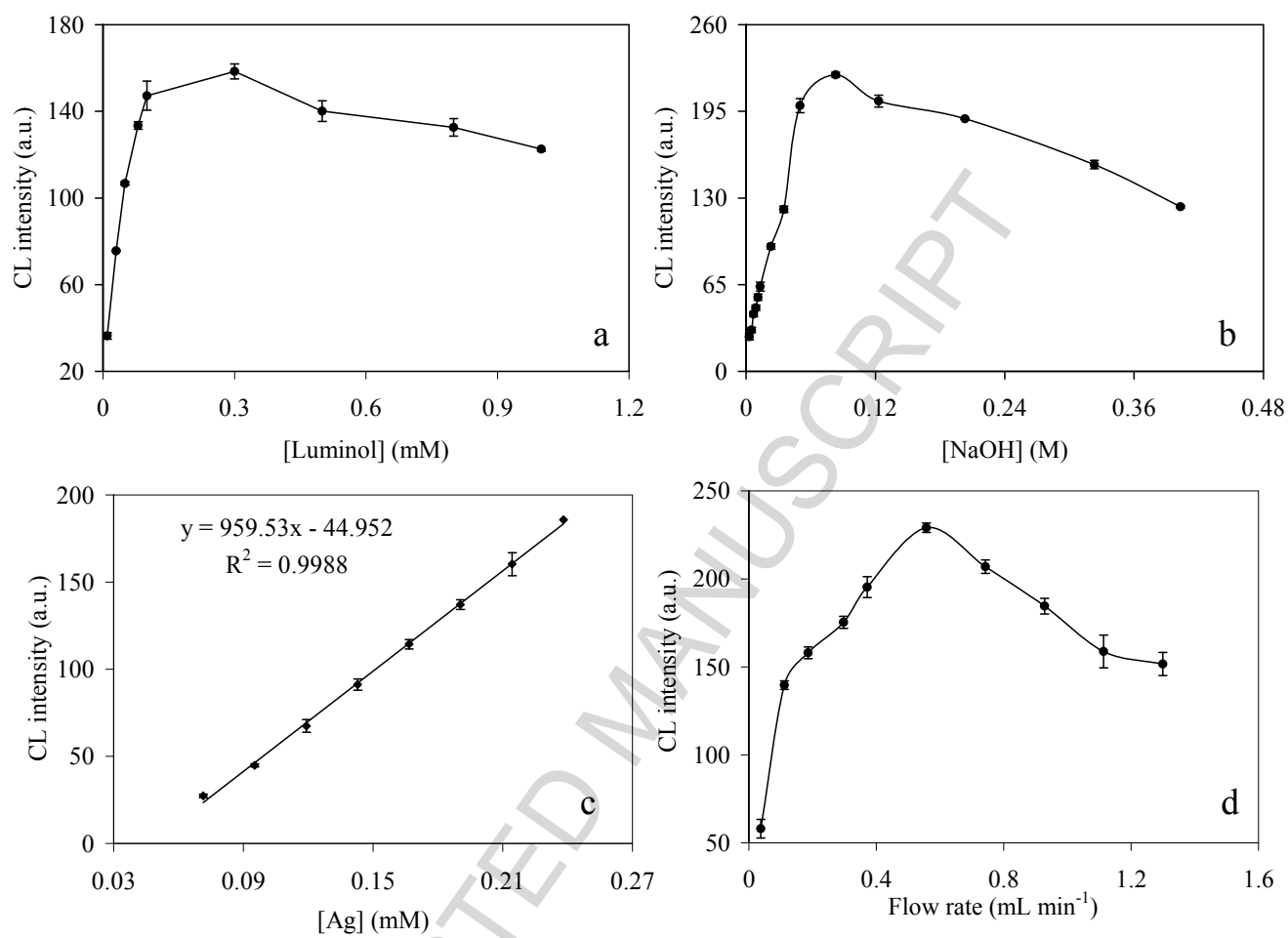

Fig. 4

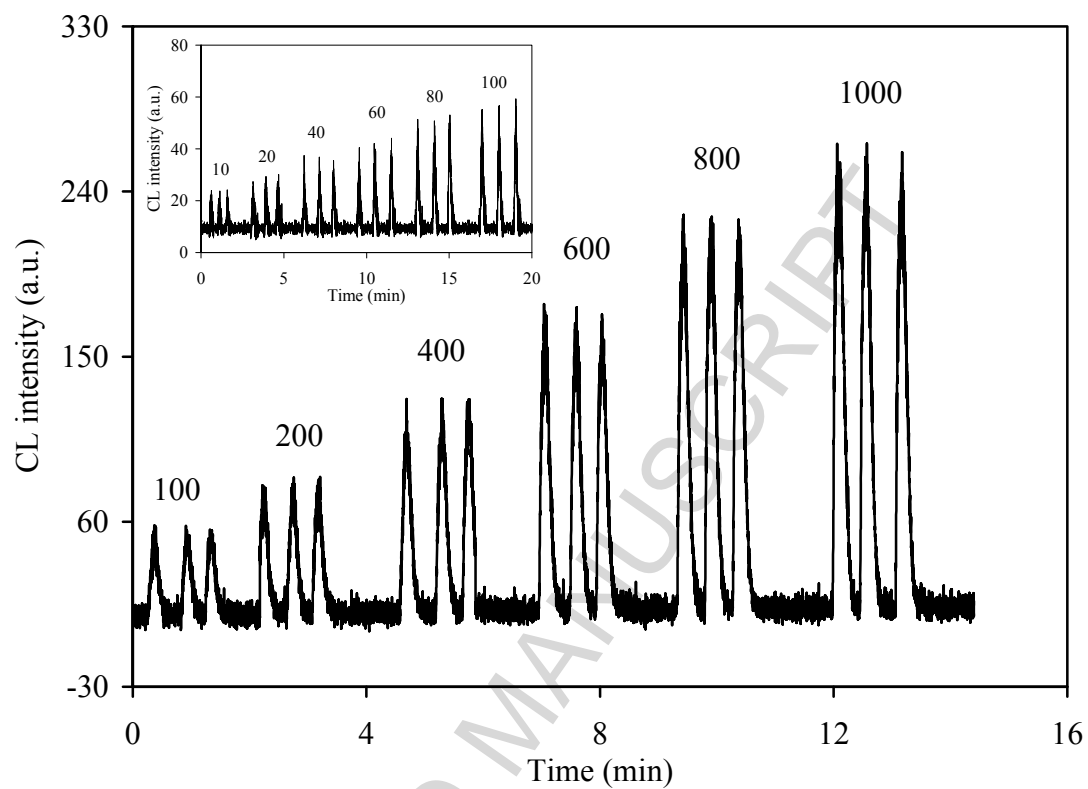
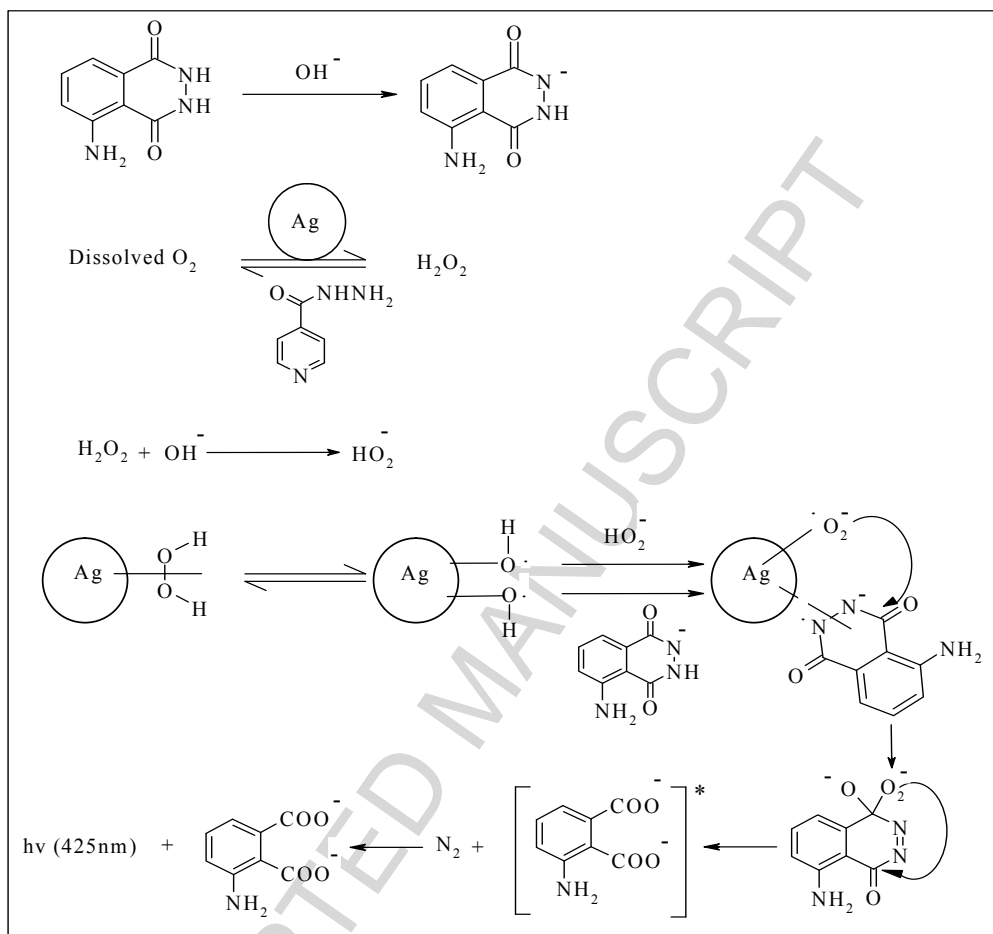

Fig. 5



Scheme 1