

МОДЕЛИРАНЕ УСТОЙЧИВОСТТА НА КОЛЕСНИ МОБИЛНИ РОБОТИ ПО КРЕН И ТАНГАЖ

MODELING THE STABILITY OF WHEELED MOBILE ROBOTS BY ROLL AND PITCH

Stoyan Lilov, Vanya Markova, Venceslav Shopov, Nikolay Popov

Institute of Robotics, Bulgarian Academy of Sciences

*E-mail: lsv@abv.bg, markovavanya@yahoo.com, vkshopov@yahoo.com,
nipopov62@gmail.com*

Abstract

This article discusses the stability of wheeled mobile robots on roll and pitch, depending on their geometric proportions, as well as the forces acting on them. A dynamic model of this type of robot is built, based on the principles of kinetostatic. The influence of the parameters of the model on the roll and pitch stability has been studied. Coefficients of stability have been introduced. The dynamic model is built in such a way that it is possible to determine intervals with values of the parameters at which roll and pitch stability is guaranteed.

Keywords: dynamic model of mobile robot; kinetostatic; coefficients of stability; simulation and modeling; roll and pitch stability.

1. INTRODUCTION

In recent years, the design of mobile wheeled robots has been the subject of great scientific and practical interest. These robots are used both indoors [4] and as autonomous vehicles [1].

Of particular interest are the autonomous mobile wheeled mechanisms. They solve various scientific tasks and problems such as: determining the trajectory of movement [2, 6, 7], following such a trajectory [3, 4]. As well as issues concerning the motion stability of such robots.

According to the principle of D’Alembert [2] – the principle of kinetostatics – the measurement of inertial force allows us to consider the robot as a body on which a balanced system of forces acts.

Thus, under a given law of motion, we can determine the support reactions and thus obtain values for the parameters of the model at which the robot will remain stable - there will be no inversion relative to the surface of motion.

In the present article, we extend the well-known [2, 3] models, by calculating the roll and pitch stability of wheeled mobile robots, using geometric and mass parameters of the construction. The model includes driving, resistance, inertial forces and support reactions, i.e. active forces, support reactions and inertial forces are included.

The article is organized as follows: in the second part we give a brief description of the kinematic, dynamic model and the implementation of the roll and pitch stability of the robot, we also introduce coefficients of stability; in the third part we study the trajectory and

accelerations to which the robot is subjected through numerical experiments; in the last part we draw conclusions about the work of the model.

2. METHODS AND MATERIALS

A. Presentation of the main indications

$O_g x_g y_g z_g$ – global Cartesian coordinate system, as in the first quadrant of $O_g x_g z_g$ contains the longitudinal projection of the structure, and $O_g x_g y_g$ is tangent to the periphery of the wheels (fig. 1);

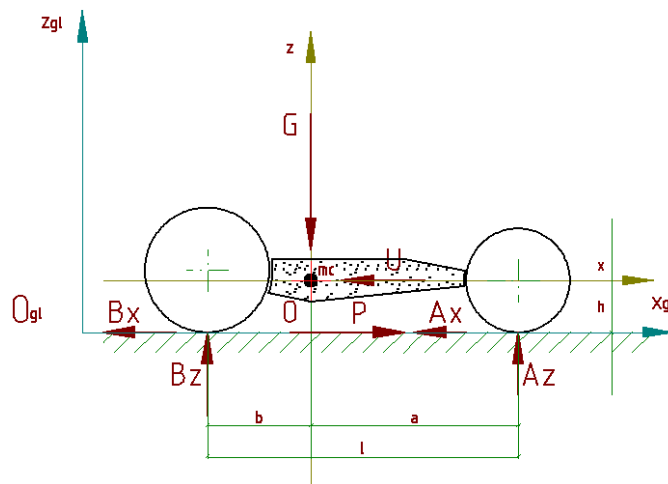

Fig. 1. Longitudinal projection of a wheeled platform

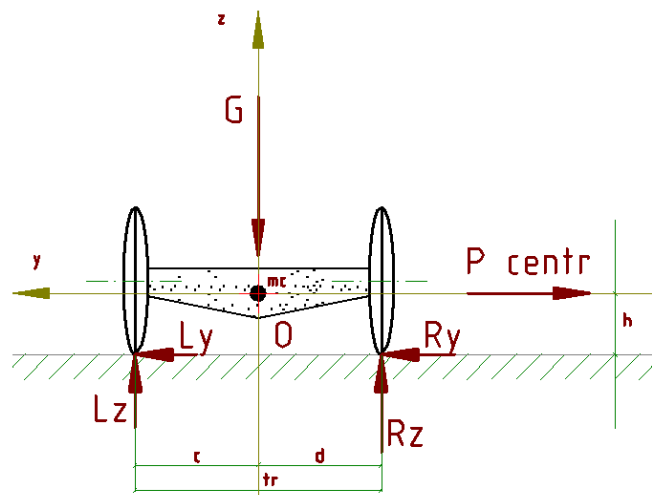

Fig. 2. Lateral projection of a wheeled platform

$Oxyz$ – Cartesian coordinate system connected to the robot body (fig. 1 and fig. 2);

m – mass;

m_c – mass center ($m_c \equiv O$);

$G = mg$ – gravity where g is the gravitational acceleration; h – distance from a given mass center to the road (according to the set tasks, bent masses can be added to the model, each with its own, local mass center, at a certain distance from the road)

P, P_{centr}, U – forces: moving, centrifugal and longitudinal inertial; a – distance from the axis z to the front axle; b – distance from the axis z to the rear axle;

l – base; tr_f – front track;

tr_r – rear track;

c_r – distance from Ox to the rear left wheel;

c_f – distance from Oxz to the front left wheel;

d_r – distance from Oxz to the rear right wheel;

d_f – distance from Oxz to the front right wheel;

A_l, A_r, B_l, B_r – support reactions acting on front left, front right, rear left and rear right wheel respectively;

$A = A_l + A_r; B = B_l + B_r$ – total support reactions acting on the front and rear axles respectively;

$L = A_l + B_l; R = B_l + B_r$ – total support reactions acting on left and right wheels respectively;

$A_{lx}, A_{ly}, A_{lz}, A_{rx}, A_{ry}, A_{rz}$ and

$B_{lx}, B_{ly}, B_{lz}, B_{rx}, B_{ry}, B_{rz}$ – projections of the support reactions along the axes of the coordinate system $Oxyz$, respectively front left, front right, rear left and rear right wheel;

\vec{a}_x – longitudinal acceleration;

\vec{a}_{xac+} – ultimate longitudinal acceleration when increasing the speed in the axial direction Ox ;

\vec{a}_{xac-} – ultimate longitudinal acceleration when decreasing the speed in the axial direction Ox ;

\vec{a}_y – transverse acceleration.

B. Kinematic and dynamic model of a wheeled mobile robot

1) Kinematic model and constraints

The kinematic model of the vehicle [5] is:

$$\begin{bmatrix} \dot{x} \\ \dot{y} \\ \dot{\phi} \end{bmatrix} = \begin{bmatrix} \cos\phi & 0 \\ \sin\phi & 0 \\ 0 & 1 \end{bmatrix} \begin{bmatrix} v \\ \omega \end{bmatrix} \quad (1)$$

The nonholonomic restriction of motion is:

$$\dot{x} \sin\phi + \dot{y} \cos\phi = 0, \quad (2)$$

which means that the achievable directions of motion are columns of the kinematic matrix:

$$S = \begin{bmatrix} \cos\phi & 0 \\ \sin\phi & 0 \\ 0 & 1 \end{bmatrix}$$

$$A = [-\sin\phi \quad \cos\phi \quad 0] \quad (3)$$

The resulting dynamic model, written in matrix form, is:

$$M(q)\ddot{q} + V(q, \dot{q}) + F(\dot{q}) = E(q)u - A^T(q)\lambda \quad (4)$$

The system can be saved in the form of a status space:

$$\dot{x} = F(x) + g(x)u, \quad (5)$$

where the state vector is: $x = [q^T; v^T]^T$.

$$M = \begin{bmatrix} m & 0 & 0 \\ 0 & m & 0 \\ 0 & 0 & J \end{bmatrix} \quad (6)$$

$$E = \frac{1}{r} \begin{bmatrix} \cos\phi & \cos\phi \\ \sin\phi & \sin\phi \\ \frac{L}{2} & -\frac{L}{2} \end{bmatrix} \quad (7)$$

$$u = [\tau_r \quad \tau_l]$$

The resulting model is:

$$\begin{bmatrix} \dot{x} \\ \dot{y} \\ \dot{\phi} \\ \dot{v} \\ \dot{\omega} \end{bmatrix} = \begin{bmatrix} v \cos\phi \\ v \sin\phi \\ \omega \\ 0 \\ 0 \end{bmatrix} + \begin{bmatrix} 0 & 0 \\ 0 & 0 \\ \frac{1}{mr} & \frac{1}{mr} \\ \frac{L}{2jr} & -\frac{L}{2jr} \end{bmatrix} \begin{bmatrix} \tau_r \\ \tau_l \end{bmatrix} \quad (8)$$

The opposite system model is obtained taking into account:

$$\begin{bmatrix} \tau_r \\ \tau_l \end{bmatrix} = \begin{bmatrix} \frac{\dot{v}mr}{2} + \frac{\dot{\omega}jr}{L} \\ \frac{\dot{v}mr}{2} - \frac{\dot{\omega}jr}{L} \end{bmatrix} \quad (9)$$

2) Support reactions caused by gravity at the robot's position on a horizontal plane

We determine the position of m_c in $O_g x_g y_g z_g$ as follows:

$$x_{g mc} = \frac{\sum m_i x_{gi}}{\sum m_i}; y_{g mc} = \frac{\sum m_i y_{gi}}{\sum m_i}, \quad (10)$$

where $x_{g mc}$, $y_{g mc}$ are the coordinates of the mass center of the structure; m_i – mass of the individual structural elements; x_{gi} , y_{gi} – coordinates of the mass centers of these elements.

We use the following two moment and one projection equations when only gravity acts (Fig. 1):

$$\sum MB_i = 0; \sum MA_i = 0; \sum x_i = 0. \quad (11)$$

The equation $\sum x_i = 0$ may be dropped because there is no acting forces projections on the x -axis other than zero.

From the moment equations it is obtained:

$$A_z = \frac{G \cdot b}{l}; B_z = \frac{G \cdot a}{l}, \quad (12)$$

where A_z и B_z are the support reactions of the front and rear axles.

The vertical support reactions for each wheel are determined similarly:

$$A_{lz} = A_z \frac{d_f}{tr_f}; A_{rz} = A_z \frac{c_f}{tr_f}; \quad (13)$$

$$B_{lz} = B_z \frac{d_r}{tr_r}; B_{rz} = B_z \frac{c_r}{tr_r}. \quad (14)$$

3) Point masses

The moment of inertia of the robot body in the system $Oxyz$ can be reported in the model if we distribute its mass appropriately in several local mass centers. For this purpose, we offer the formulas below, if the coordinates of the mass center and the basic geometric dimensions are known. This is in case we do not know the moment of inertia.

According to the supporting reactions from 2) we determine point masses:

$$m_f = m \frac{b}{l}; m_r = m \frac{a}{l}, \quad (15)$$

with mass centers m_{cf} , m_{cr} for front and rear axle and:

$$m_{fl} = m_f \frac{d_f}{tr_f}; m_{fr} = m_f \frac{c_f}{tr_f}; \quad (16)$$

$$m_{rl} = m_r \frac{d_r}{tr_r}; m_{rr} = m_r \frac{c_r}{tr_r} \quad (17)$$

with mass centers m_{cfl} , m_{cfr} , m_{crl} , m_{crr} , respectively for front left, front right, rear left and rear right wheel.

If there are no other landmarks, the coordinates of the local mass centers are taken at the height of the mass center, for the axles centrally, and for the wheels – at the point of contact with the road.

4) Roll and pitch stability

At this point we will derive the equations for roll and pitch stability under the following conditions (Fig. 1 and Fig. 2):

- $tr_f = tr_r = tr$; $c_r = c_f = d_r = d_f = \frac{tr}{2}$;
- when turning, the axles of all the wheels are parallel to P_{centr} and axle Oy ;
- the mass is concentrated in m_c .

4.1) Pitch stability

We consider the following two moment and one projection equations:

According to (11), we obtain:

$$A_z = \frac{Gb-Uh}{l}; B_z = \frac{Uh+Ga}{l}; \quad (18)$$

$$P - U = B_x + A_x. \quad (19)$$

B_x and A_x are forces of resistance as a result of moving on a given surface, therefore:

$$B_x = fB_z; A_x = fA_z, \quad (20)$$

where f is the coefficient of rolling friction. So:

$$B_x + A_x = f(B_z + A_z); \frac{B_x}{A_x} = \frac{fB_z}{fA_z} = \frac{B_z}{A_z}. \quad (21)$$

And we have:

$$\begin{cases} P - U - B_x - A_x = 0 \\ B_x + A_x = f(B_z + A_z) \\ \frac{B_x}{A_x} = \frac{B_z}{A_z} \end{cases} \quad (22)$$

The formulas above give values of the magnitudes A_x , B_x , P , f , and either P , or f remains as a parameter.

We introduce the following coefficients:

- coefficient of stability at $\vec{a}_x > 0$: $K_{\vec{a}_{xac+}} = \frac{h}{b}$;
- coefficient of stability at $\vec{a}_x < 0$: $K_{\vec{a}_{xac-}} = \frac{h}{a}$;
- base coefficient of stability: $K_{com} = \frac{h^3}{abl}$.

4.2) Roll stability

We consider the following two moment and one projection equations:

$$\sum M L_i = 0; \sum M R_i = 0; \sum y_i = 0. \quad (23)$$

And we have:

$$\begin{aligned} R_z &= \frac{P_{centr} \cdot h + G \cdot c}{tr}; \quad L_z = \frac{G \cdot c - P_{centr} \cdot h}{tr}; \\ P_{centr} &= R_y + L_y. \end{aligned} \quad (24)$$

R_y and L_y are forces of resistance against lateral slip-on a given surface of motion, therefore:

$$L_y = \mu L_z; \quad R_y = \mu R_z, \quad (25)$$

where μ is the coefficient of adhesion. So:

$$L_y + R_y = \mu(L_z + R_z); \quad \frac{L_y}{R_y} = \frac{\mu L_z}{\mu R_z} = \frac{L_z}{R_z}. \quad (26)$$

And we have:

$$\begin{cases} P_{centr} = R_y + L_y \\ L_y + R_y = \mu(L_z + R_z) \\ \frac{L_y}{R_y} = \frac{L_z}{R_z} \end{cases} \quad (27)$$

The formulas above give values of the magnitudes L_y , R_y , P_{centr} , μ , and either P_{centr} , or μ remains as a parameter.

3. EXPERIMENTS AND RESULTS

We calculate the required torques so that the mobile robot moves along the reference trajectory: $xr = 1.1 + 0.7\sin(2\pi/30)$; $yr = 0.9 + 0.7\sin(4\pi/30)$.

The simulation calculates the torque of the robot using the inverse dynamic model and displays the trajectory of movement (fig. 3).

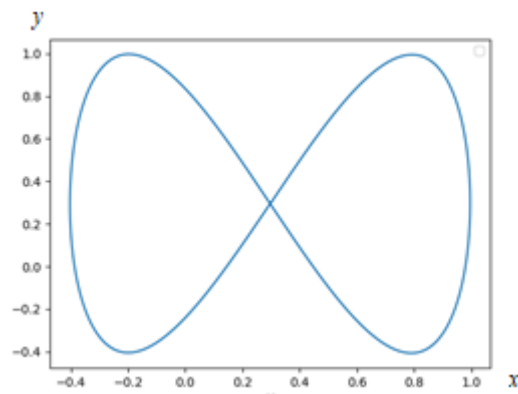

Fig. 3. Trajectory of robot movement

The parameters of the robot are:

- mass $m = 1.17$ kg;
- moment of inertia $J = 0.001$ kg/m²;
- base $l = 0.30$ m;
- radius of the driving wheels $r = 0.06$ m;
- track $tr = 0.20$ m.

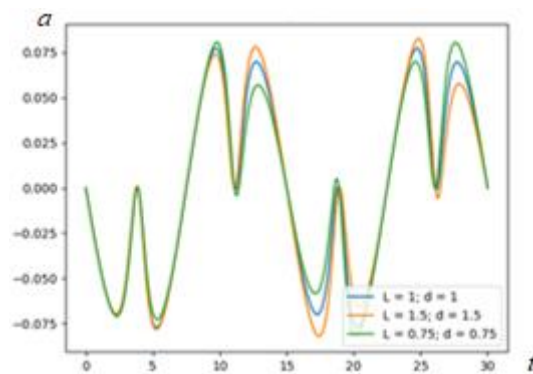

Fig. 4. Longitudinal acceleration

Figure 4 and figure 5 are shown acceleration of the m_c of the robot using the inverse dynamic model.

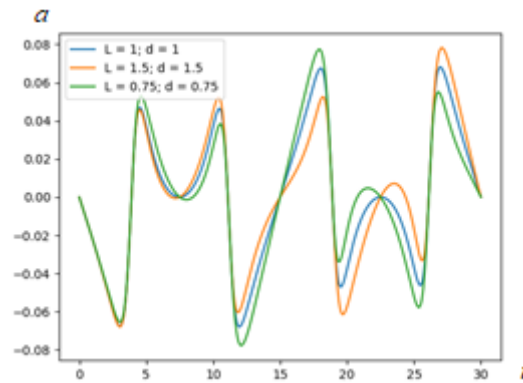

Fig. 5. Transverse acceleration

With the parameters thus selected, the roll and pitch resistance of the robot is guaranteed.

Here we will calculate the limiting longitudinal accelerations in rectilinear motion. The values for m_i , x_i and y_i in Table 1 will be used in these calculations.

Table 1. Mass and geometrical parameters of the robot

	Name of the structural element	m_i [kg]	x_i [m]	y_i [m]
1	battery	0.35	0.174	0.048
2	left engine	0.1	0.2	0.05
3	right engine	0.1	0.2	0.05
4	rear left wheel	0.04	0.12	0.06
5	rear right wheel	0.04	0.12	0.06
6	front left wheel	0.02	0.42	0.05
7	front right wheel	0.02	0.42	0.05
8	body	0.5	0.26	0.05

Thus, for the position m_c [m]:

$$x_{g\ mc} = \frac{\sum m_i x_{gi}}{\sum m_i} = 0.22; \quad y_{g\ mc} = \frac{\sum m_i y_{gi}}{\sum m_i} = 0.05.$$

Respectively $a = 0.2$; $b = 0.1$; $l = 0.3$; $h = 0.05$.

The total mass is $m = 1.17$ kg.

From (11) we have:

$$A_z \cdot l + U \cdot h - G \cdot b = 0;$$

$$U \cdot h + G \cdot a - B_z \cdot l = 0;$$

$$P - U + A_x + B_x = 0.$$

At $\vec{a}_x \gg 0$ we assume that $A_x \approx 0$; $A_z \approx 0$, as their values are insignificant compared to those of P and U . Then: $P = U \geq 22,96$ N and $A_z \leq 0$, i.e. stability is lost, and the allowable acceleration is:

$$\vec{a}_{xac+} = \frac{U}{m} = 19.62 \text{ m/s}^2.$$

At $\vec{a}_x \ll 0$, when the acceleration is close to the limit in terms of stability, we assume that $B_x \approx 0$, as $B_z \approx 0$, because at such a negative acceleration almost all the load is transferred to

the front axle (and front brakes). It is also logical $P = 0$. Then: $A_x = U \geq 45.9$ N and $B_z \leq 0$, i.e. stability is lost, and the allowable negative acceleration is:

$$\vec{a}_{xac-} = \frac{U}{m} = 39.24 \text{ m/s}^2.$$

The coefficients introduced in 4) give us the following dependencies:

$$\text{If } m = \text{const}; K_{\vec{a}_{xac+}} = \frac{h}{b} = \text{const}; K_{\vec{a}_{xac-}} = \frac{h}{a} = \text{const}, \text{ then:}$$

$$\vec{a}_{xac+} = \text{const}; \vec{a}_{xac-} = \text{const}.$$

On the other hand, the closer the values of the coefficients are to zero, the more stable the construction is for the respective case.

CONCLUSION

A kinetic and dynamic model of a robot based on the principles of kinetostatics has been built. The roll and pitch stability of wheeled mobile robots have been added to the model, depending on their geometric proportions, as well as the forces acting on them. The influence of the parameters of the model on its roll and pitch stability has been studied. The dynamic model is built in such a way that it is possible to determine intervals with values of the parameters at which the roll and pitch stability is guaranteed.

REFERENCES

- [1] I. Evtimov, R. Ivanov (2016). "Electric cars", "Angel Kanchev" University of Ruse, Ruse, (ЕВТИМОВ, И. ИВАНОВ Р. Електромобили, Русенски университет „Ангел Кънчев“, Русе, 2016 г.)
- [2] G. Klančar, et al. (2017). "Wheeled mobile robotics: from fundamentals towards autonomous systems", Butterworth-Heinemann,
- [3] G. Klančar, S. Blažič, (2019). "Optimal constant acceleration motion primitives". IEEE Transactions on Vehicular Technology 68.9, 8502-8511.
- [4] X. Lang. (2013). "A Trajectory Tracking Controller Design for a Nonholonomic Mobile Robot", 1-10.
- [5] B. Siciliano, O. Khatib, (ed.). (2016). "Springer handbook of robotics", Springer.
- [6] G. Tianyu, J.M. Dolan, J.W. Lee. (2016). "On-road trajectory planning for general autonomous driving with enhanced tenability". Intelligent Autonomous Systems, 13, Springer, Cham, 247-261.
- [7] Y. Zhang, et al. (2018). Hybrid trajectory planning for autonomous driving in highly constrained environments. IEEE Access, 6, 32800-32819.