



---

## **Environmental and Economic of Flooring Building Materials**

**Nachawit Tikul\***

Faculty of Architecture and Environmental Design, Maejo University, Chiang Mai, Thailand

\*Corresponding Author: [nachawit@gmail.com](mailto:nachawit@gmail.com)

### *Article history*

Submitted: 28 June 2013/ Accepted: 16 November 2013/ Published online: 17 February 2014

---

### **Abstract**

Green building design requires use of building materials that minimize environmental impact, necessitating selection of building materials by their environmental profile as well as economic cost-benefit considerations. The objective of this research is to determine the environmental impacts per square meter of three flooring materials; ceramic tiles, marble tiles, and parquet produced in Thailand. Life cycle cost (LCC) of the three materials are determined and compared. The study finds that ceramic tiles cause the greatest environmental impact, especially during the material extraction phase. When calculating all costs incurred throughout the life-cycle, the cost of untreated solid wood parquet is highest.

**Keywords:** Environment; Economic; Building material; Ceramic tile; Marble tile; Parquet

---

### **Introduction**

Selecting materials for building traditionally involves the following considerations; functionality, cost, aesthetics and the personal preferences of designers and owners. Past experience of designers also plays a key role in the selection process. Environmental impacts of building materials are emerging as an increasingly important consideration [1-2]. The challenge for modern building designers, architects and engineers, as well as building owners, is therefore to improve the environmental friendliness of buildings while also meeting traditional requirements such as functionality and cost.

To meet the challenge, building designers need to have accurate and reliable data for building materials, in order to enable meaningful comparisons among alternatives. To evaluate environmental impacts of buildings, reliable life cycle assessment (LCA) data of building materials are required [3-4]. To estimate accurate cost, data and information required to calculate the life cycle cost (LCC) of materials are necessary. Efforts have been made to determine environmental impact values of various building materials. Existing data in the literature reveal that the impact values of the same material vary widely from one source to another [5-6]. Differences in such values are due to several factors including

manufacturing practice, production technology, transportation distances, and temporal factors [7]. LCA values of any particular material are therefore not constant, but may depend upon a number of parameter in manufacture and use. Thus, to obtain accurate data, the environmental impact values of any building material should be determined locally. The impact values of ceramic tiles produced in Thailand, for example, will necessarily differ from those of the same materials produced in other countries.

Cost is always important, particularly in an age of fierce competition, and especially in developing countries where customers are highly cost-conscious. Thus, environment-friendly materials will never be selected if the cost is excessive. Environmental impact of materials and cost need to be considered together, and a compromise reached in making the final selection decisions. Typically, building designers and owners consider only the initial cost of materials rather than the life cycle cost [1,8]. This could be misleading as low initial cost might result in high overall life cycle cost. Life cycle cost therefore offers a more accurate cost estimation process, and is comparable to estimation of environmental impact of materials [1,9].

Among the most popular flooring materials are ceramic tiles, marble tiles, and parquet. In Thailand, for example, these three flooring materials constitute around 80% of all flooring materials used in the country [10]. Environmental impact values of these three important building materials have never been determined, and thus comparison among them has never been made. It will be extremely useful for practicing building designers, architects and engineers if reliable environmental impacts values of these materials are available [11,12, 13]. As cost is a very important factor in the materials selection equation, life cycle cost of these materials will also be very useful.

The objective of this research is to determine environmental impacts of three flooring materials; ceramic tiles, marble tiles, and parquet produced in Thailand. The values will then be compared among the three materials and with those exist in the literature. Life cycle cost (LCC) of the three materials will also be determined and compared. The results of this research will be useful for building designers and owners in selecting the most appropriate and optimum flooring materials.

### **Materials and methods**

This research was divided into two parts. The first part assesses the environmental impact of building materials by using LCA ISO 14040-44:2006 [14, 15]. The second part estimates cost of construction materials by using the life cycle cost (LCC) approach.

#### **1) Environmental impact assessment**

All data required for environmental impact assessment were collected at the plant by on-site measurements and from actual manufacturing practice of the plant during March 2008 to February 2009. Data were collected in accordance with ISO 14040:2006 and ISO 14044:2006 standards. The inventory data of the system were characterized, normalized and weighted according to the Eco-indicator 95 methodology. Floor covering materials i.e. marble tiles, ceramic tiles and untreated solid wood parquets were analyzed for the environmental impact as well as the product life-cycle, from 'cradle to grave'. This life cycle is divided into eight phases: namely material extraction, transportation of all raw materials to the plant, material production, transportation of finished products to construction sites, construction or installation, use phase, demolition and end-of-life phases, taking into account the major four environmental problems i.e. global warming, acidification, eutrophication

and ozone depletion. Because LCA-based analysis demands intensive calculation, SimaPro 7.2 LCA software was used to process the data and calculate the environmental impacts.

Data for material extraction, transportation of all raw materials and material production phases were collected directly from the 3 producers who are major actors in each industry. Data for the installation phase (i.e. volume of materials for installation and installation method) were collected from the contractors at the construction sites. Data for the use and maintenance phase were collected by interviewing skilled technicians and owners of construction projects. Their validity was subjected to plausibility checks, based on cross-calculations and comparisons with the sum of products and by-products. Generic data are based on the Thai national database (e.g. electricity, diesel, transportation) and the Ecoinvent database which provides information closest to the situation in Thailand. Data collection methods for other stages of the life cycle and system boundaries are described in the inventory analysis (Section 3). The inventory data of the system were characterized according to the Eco-indicator 95 methodology. The functional units and details of materials used for comparison are shown in Table 1.

The mass allocation procedure is necessary for marble tiles (mining) and ceramic tiles (body

preparation, forming and biscuit firing). The untreated solid wood parquets need to include system expansion for energy recovery since the thermal energy leaves the system under analysis and is then used in a different system.

## 2) Economic assessment

The life cycle costs of marble tiles, ceramic tiles and untreated solid wood parquets were calculated following the ASTM Standard Method for Measuring Life Cycle Costs of Buildings and Building System (E 917-05) [17], which consists of initial cost and future cost. Initial cost refers to the cost of floor covering materials, installation materials and labor cost. These initial cost data are provided by the Ministry of Commerce. Future cost refers to the cleaning, maintenance and demolition cost arising throughout the life cycle of that material, and is calculated at an inflation rate of 10% p.a., and other data are obtained from interviews in respect of use behavior and maintenance requirements. Collection of empirical data such as construction performance and cleaning, maintenance and replacement was conducted by survey and direct observation of eight case studies, supplemented and cross-checked by informal interviews. These data were collected from manufacturers, suppliers and contractors [9] and an average was calculated for conducting the LCC.

**Table 1** Functional units of materials

Floor covering materials	Specific weight (kg/m <sup>2</sup> )	Size (cm)	Description	Assumed lifetime(years)
Marble tiles	51.3	30x60x1.9	Natural color (Saraburi)	50
Ceramic tiles	10.57	9.8x9.8x0.5	Light color (SakhonNakhon)	50
Untreated solid parquets	18	2.5x10x35	<i>Shoreaobtusa</i> (Ayutthaya)	50

### 3) Inventory analysis

#### 3.1) Marble tiles life cycle

The life cycle of marble begins from the mining of marble from the quarry and manufacture of marble blocks, comprising the following steps: drilling, cutting and splitting. Thereafter, the blocks are transported (hailed) by hydraulic crane and truck to the manufacturing plant. At the plant, the marble blocks are cut into sheets of the required thickness and further cut into the required sizes using a gang saw. The tiles are then polished to specification before being sorted by color and placed on pallets ready for transportation to customers.

Calculation of the environmental impact of marble production does not include the environmental impact arising from use of diamond wire, saw blade, polishing, waxes and other machine maintenance equipment. All waste water from the manufacturing process is passed through a filtering process and reused. Sludge from the waste water filter process is stacked up before being used for manufacturing construction bricks.

The average distance of round-trip transportation of marble tiles from the manufacturing plant to the construction sites by 10-wheel truck with a 20-ton load is 300 km, but tonnage of the trip without material load averages 10 tons per trip. The installation phase involves placing the tiles according to the required pattern using cement as a binder. Data on using the materials are derived from interviews of construction project contractors. The environmental impact from grouting materials used in the installation process is not considered.

In the use phase, weekly dust suction by 1500 W vacuum with a suction rate of 9 minutes/m<sup>2</sup> and cleaning of marble tile floor with water are required. The demolition and end-of-life phases include actual demolition and transportation of wastes to landfill sites where the marble tile waste is finally buried. The average distance round trip transportation

by a 10 wheel truck with 20 ton load is 60 km as detailed in Figure 1.

#### 3.2) Ceramic tiles life cycle

The life cycle begins by mining the raw materials, primary processing and transport directly to the manufacturing plant. The raw materials are used to produce the body and the glazing of the tile. The glazing preparation commences from crushing and mixing feldspar, color stain, kaolin, zirconium and frit in a ball mill in the specified proportions.

In regard to the body preparation, raw materials are crushed and mixed in a ball mill (Table 2) for 10-12 hours. From this process, slips are produced and put in the spray drying process to turn to soil powder with 6%-7% humidity then formed by a hydraulic machine. Subsequently, ceramic tiles are then dried to eliminate humidity. The tunnel kiln has the same features as a biscuit kiln and glaze kiln, and the inner temperature of the kiln is approximately 100°C; the heat energy in the kiln derives from the heat energy from the end of the draught and glaze kilns. Tiles remain in the kiln for around 28 hours by which the humidity is eliminated to less than 10%. Thereafter, the tiles pass the biscuit firing process at 1,120°C for around 38 hours. LPG is used as fuel for this process.

**Table 2** Raw materials for producing 1 m<sup>2</sup> of ceramic tile

Body Materials		Glazing Materials	
Category	Quantity (kg)	Category	Quantity (kg)
White Clay	0.426	Frit	0.085
Ball Clay	0.106	Kaolin	0.006
Pyrophyllite	0.339	Feldspar	0.013
Pottery Stone	0.088	Zirconium	1.60E-04
Limestone	0.088	Alumina	2.20E-04
		Ball	04
		STTP	9.00E-05

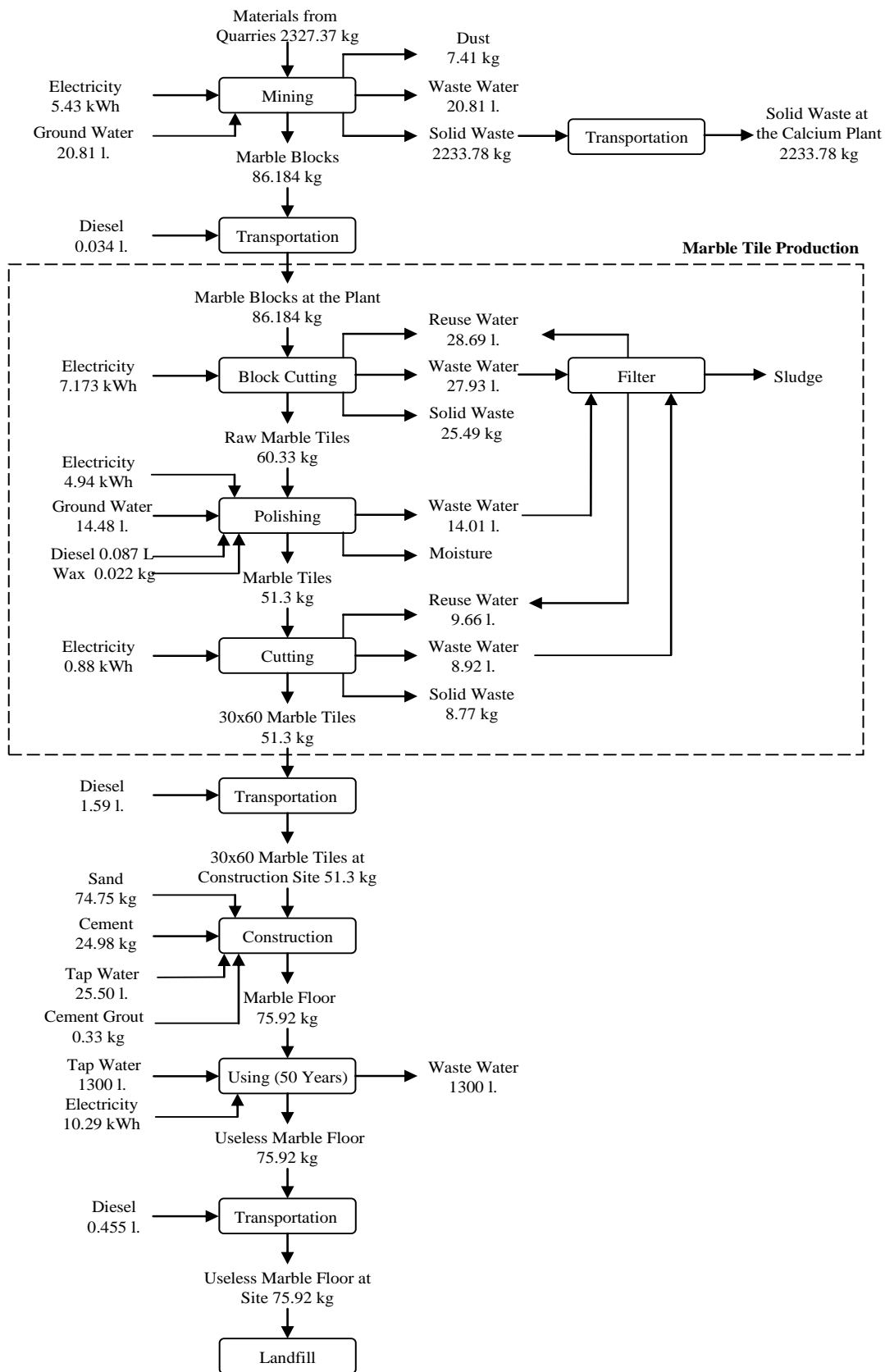

Figure 1 Life cycle inventory of 1 m<sup>2</sup> marble tiles.

The average round trip transportation of ceramic tiles from the manufacturing plant to the construction site by a 10-wheel truck with a 20-ton load is 150 km. The process of installation, use and demolition of ceramic tiles is the same as for marble tiles, differing only in terms of volume of material and fuel (Figure 2).

### 3.3) Life cycle of untreated solid parquet

The life cycle of parquet tiles begins with the cutting of Shorea obtusa trees from natural forests in Lao PDR. In this process, gasoline is used as fuel for power saws. Thereafter, logs are transported by cable and crawler tractor from the forest to the sawmill, using diesel as the fuel for machinery used for moving, binding and dragging logs to the saw. The logs are sliced into rectangular-section wood at the trim table, using electrically powered machinery. Subsequently, the lumber is piled up for onward road transportation by 10-wheel truck with 20-ton load from Lao PDR into Thailand. The average round-trip distance is 1,760 km.

When the lumber arrives at the plant, the wood is first aerated indoors and dried by fans and kiln to reduce moisture content. This process consumes 71.62 kWh/m<sup>2</sup> in electricity, and 240 kg/m<sup>2</sup> of LPG. The dried lumber is then planed and wedged, with total electricity consumption of 3,104.7 kWh/m<sup>2</sup>. Later, the tiles will be belted with 2.5 m of plastic thread per 1 m<sup>2</sup> and transported to a construction site in Bangkok with the round-trip distance of 320 km for installation. The process of preparing the concrete or cement surface with humidity control is not included in the cost estimation. The untreated solid wood parquet is bound to the concrete flooring by latex glue at a rate of 1.75 kg/m<sup>2</sup>. The finished flooring is then scrubbed the surface with a 1500 W sander

for 5.3 minutes/m<sup>2</sup>, graduating from rough to fine sandpaper and cleaning by a 2500 W vacuum cleaner twice for 1.2 minutes/m<sup>2</sup>. Thereafter, the floor will be coated by five coats of polyurethane varnish, totaling 0.714 l/m<sup>2</sup>. In regard to the environmental impact assessment, the production of glue and polyurethane but not the production of sander and sandpaper are also taken into account.

From interviews with the manufacturers and technicians who lay the untreated solid wood parquet tiles, it was found that weekly cleaning and scrubbing by a 1500 W vacuum cleaner for an average period of 9.5 minutes/m<sup>2</sup> is required. In addition, the wood floor will be scrubbed and recoated by skilled technicians every 10 years on average. After use, untreated solid wood parquet floors will be fired as firewood (Figure 3).

## 4) Environmental performance

### 4.1) Energy consumption

From Figures 1-3, kWh of electricity as the input data for each building material were converted to MJ (1kWh=3.6 MJ). It was found that the ceramic tile life cycle consumes the largest energy amount of 1,457 MJ/m<sup>2</sup>, with the material extraction phase consuming the greatest proportion of total energy, followed by ceramic tile transportation and production. For marble tiles, the energy consumed throughout the life cycle is 339 MJ/m<sup>2</sup>, with the tile production process being the most energy-intensive, followed by the use phase of 50 years. For untreated solid wood parquet tiles, it is deemed that the consumed energy is recovered since they are subsequently used as firewood at the end of their life, generating thermal energy of 14 MJ/kg. The energy covered from untreated solid wood parquets throughout their life cycle is 18 MJ/m<sup>2</sup> (Table 3).

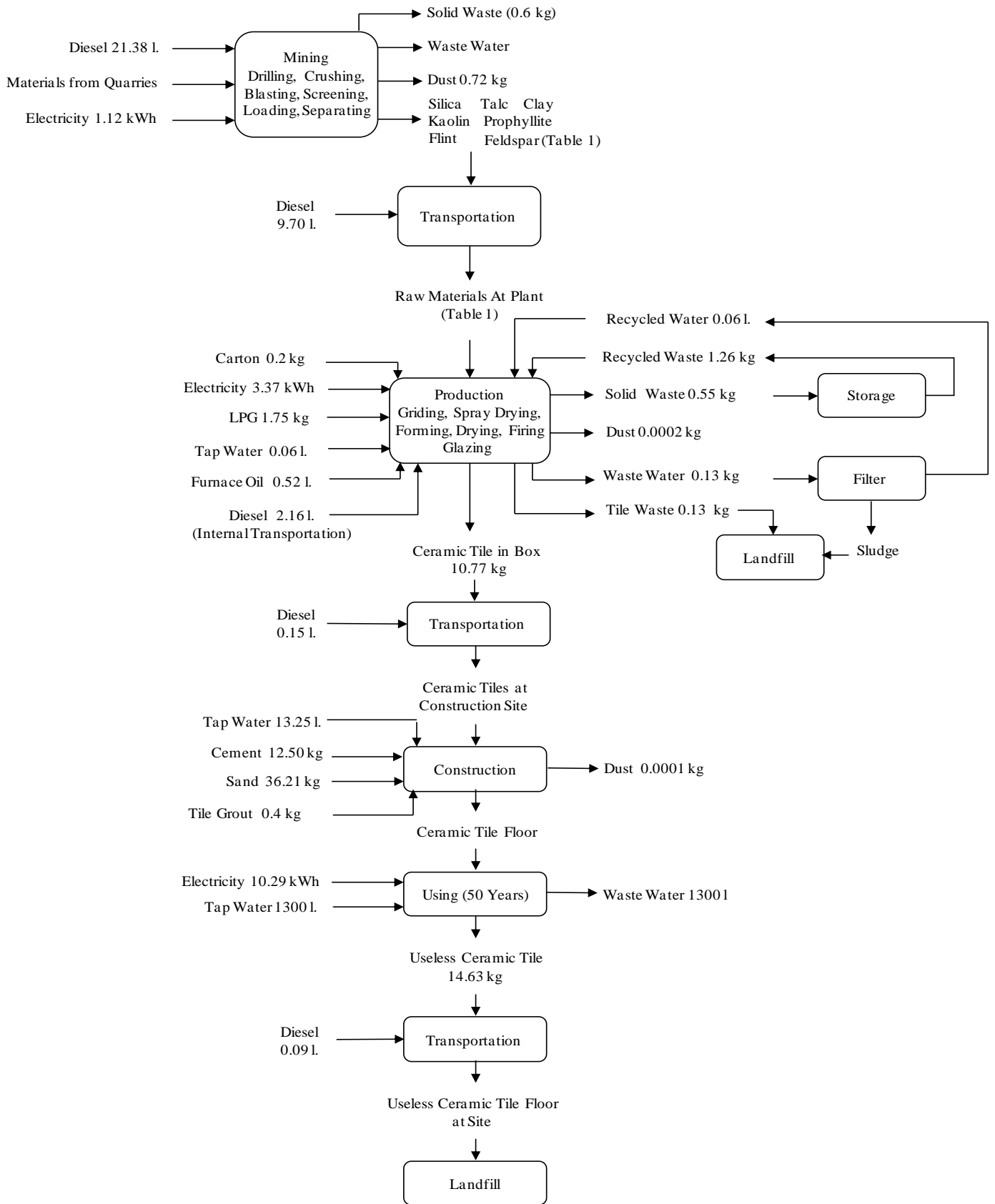

**Figure 2** Life cycle inventory of 1 m<sup>2</sup> ceramic tiles.

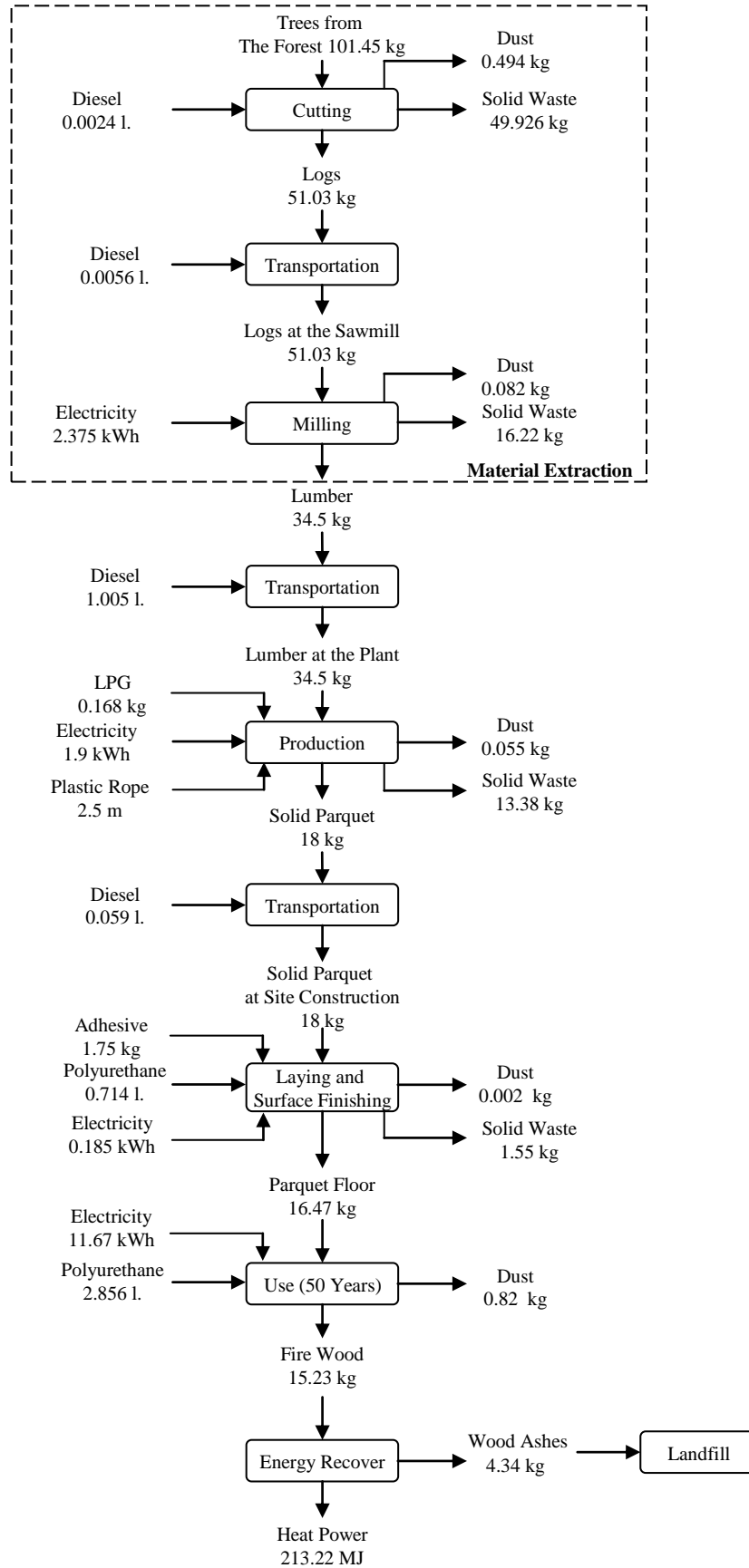

Figure 3 Life cycle inventory of 1 m<sup>2</sup> untreated solid parquet.



**Table 3** Energy consumption per 1m<sup>2</sup> of three flooring materials

Life cycle phase	Marble tiles		Ceramic tiles		Solid wood parquet	
	MJ	(%)	MJ	(%)	MJ	(%)
Extraction	49.93	14.75	788.96	54.16	22.14	11.34
Transportation 1	1.25	0.37	337.28	23.16	36.60	18.75
Manufacturing	119.57	35.31	226.83	15.57	25.26	12.94
Transportation 2	56.05	16.55	5.46	0.37	2.15	1.10
Construction	0.00	0.00	0.00	0.00	1.70	0.87
Using	94.67	27.96	94.67	6.50	107.36	55.00
Transportation 3	16.59	4.90	3.28	0.23	0.00	0.00
Disposal	0.54	0.16	0.11	0.01	-213.22	
Total	338.60	100.00	1456.6	100.00	-18.01	100.00

#### 4.2) Impact assessment

The data in Figure 1-3 were used as inputs for impact assessments and SimaPro 7.1 LCA software was used to calculate the respective environmental impacts. The impact assessment results on four key environmental problems caused by marble tiles, ceramic tiles and untreated solid wood parquet are shown in Table 4-5. It is found that ceramic tiles cause the most environmental problems, especially at the material extraction phase. If each problem and life cycle is considered in detail, it is found that ceramic tiles do not render the most environmental impact in every phase of its life cycle.

The data indicate that the material extraction phase of ceramic tiles causes the most global warming, while production and transportation

of marble tiles to the construction site causes most global warming. Furthermore, the use and construction of untreated solid wood parquets causes the most environmental impact. Regarding ozone depletion, acidification and eutrophication, it is found that the material extraction phase of ceramic tiles brings the most environmental impact, while production and transportation of marble tiles to a construction site causes the most environmental impact, and the use and construction of untreated solid wood parquets causes the most impact. In addition, it is found that all environmental problems of untreated solid wood parquets are negative, whilst the disposal phase offers environmental benefits.

**Table 4** Global warming potential and ozone layer potential per 1 m<sup>2</sup> of flooring materials

Life cycle phase	Global warming (kgCO <sub>2</sub> )			Ozone layer (kg CFC <sub>11</sub> )		
	Marble tiles	Ceramic tiles	Solid wood parquet	Marble tiles	Ceramic tiles	Solid wood parquet
Extraction	1.56E+00	1.31E+01	3.61E+00	6.54E-08	1.07E-04	1.39E-07
Transportation 1	2.77E-01	4.25E+00	4.59E-01	5.05E-07	3.89E-05	4.20E-06
Manufacturing	5.43E+00	4.71E+00	2.00E+00	2.72E-07	9.31E-06	6.14E-08
Transportation 2	1.67E+00	6.86E-02	2.69E-02	3.13E-06	6.28E-07	2.46E-07
Construction	3.96E+00	4.74E+00	4.02E+00	1.55E-07	9.25E-08	3.09E-05
Using	1.34E-02	1.08E+01	1.48E+01	2.02E-08	3.47E-07	3.71E-05
Transportation 3	1.56E-01	4.11E-02	2.15E-02	2.85E-07	3.76E-07	1.96E-07
Disposal	1.91E-01	4.26E-02	-5.29E+00	3.48E-07	7.74E-08	-2.74E-08
Total	1.33E+01	3.77E+01	1.96E+01	4.78E-06	1.57E-04	7.28E-05

**Table 5** Acidification potential and eutrophication potential per 1 m<sup>2</sup> of flooring materials

Life cycle phase	Acidification (kgSO <sub>2</sub> )			Eutrophication (kgPO <sub>4</sub> )		
	Marble tiles	Ceramic tiles	Solid wood parquet	Marble tiles	Ceramic tiles	Solid wood parquet
Extraction	6.83E-03	1.28E-01	2.15E-02	4.01E-04	1.21E-02	1.38E-03
Transportation 1	1.17E-03	4.34E-02	4.69E-03	1.61E-04	4.19E-03	4.52E-04
Manufacturing	2.41E-02	3.78E-02	1.22E-02	1.43E-03	3.13E-03	8.11E-04
Transportation 2	1.47E-02	7.01E-04	2.75E-04	2.07E-03	6.76E-05	2.65E-05
Construction	6.84E-03	1.63E-02	1.84E-02	9.10E-04	1.78E-03	2.30E-03
Using	1.59E-04	6.37E-02	8.84E-02	1.13E-05	4.11E-03	6.87E-03
Transportation 3	6.59E-04	4.20E-04	2.19E-04	9.10E-05	4.05E-05	2.11E-05
Disposal	9.59E-04	2.13E-04	-4.68E-03	1.38E-04	3.08E-05	-4.44E-03
Total	5.54E-02	2.90E-01	1.41E-01	5.21E-03	2.54E-02	7.41E-03

## 5) Economic Performance

### 5.1) Initial cost

The initial cost is the sum of construction material prices, installation material prices and installation cost. Construction material prices were based on 2009 updated average prices provided by the Ministry of Finance. It is found that the prices of a 30 cm x 60 cm marble tile, 8" x 8" light-color ceramic tile and 1" x 4" x 15" untreated solid wood parquet made from *Shoreaobtusa* are Baht 585/m<sup>2</sup>, Baht 265/m<sup>2</sup> and Baht 750/m<sup>2</sup>, respectively. Information on costs of cement, sand and water for installation of marble tiles and ceramic tiles, glue and wood coating are average figures obtained via interviews with project technicians and contractors. The cost of water supply and electricity are Baht 10/cm<sup>3</sup> and Baht 3/kW, respectively.

### 5.2) Future cost

Future cost is the sum of the cost incurred while using, and the disposal cost for the period of 50 years at an inflation rate of 10%. The cost incurred while using includes electricity charges, cleaning, water supply charges (cleaning and floor scrubbing costs are as per the details in topics 3.2 to 3.4). Also, cost of disposal of material after use is also considered. Ceramic and marble tiles are disposed of via landfill with an average expense

of Baht 5.13 and 24.61/m<sup>2</sup>, respectively, whilst untreated solid wood parquet is sold as firewood. The average purchase price of parquet tiles made from *Shoreaobtusa* is Baht 96.46/m<sup>2</sup>. Thus, the future cost is calculated according to the equation:

$$F = \sum_{n=1}^{2599} [P_1(1+ni)] + P_2(1+ni) \quad (1)$$

F : future value (Baht)

P<sub>1</sub> : present value (cost for cleaning in Baht)

P<sub>2</sub> : present value (cost for landfill in Baht)

n : the number of weeks

i : % of inflation rate per week (0.001923)

Weekly cleaning of all three building materials throughout 50 years is required, with the cost of Baht 5/m<sup>2</sup>/week. However, untreated solid wood parquets will also be scrubbed every 10 years i.e. 10, 20, 30 and 40 years, representing an annual cost of Baht 526.75/m<sup>2</sup>. At the end of 50th year, marble ceramic tiles will be disposed of via landfill at an average cost of Baht 36.75 and 11.14/m<sup>2</sup>, respectively, whilst untreated solid wood parquet tiles are sold as firewood at an average of Baht 22.85/m<sup>2</sup>.

When calculating all costs incurred throughout the life-cycle, the cost of untreated solid wood parquet is the highest, both in terms of initial

**Table 6** Life cycle cost of per 1 m<sup>2</sup> of flooring materials

Cost list	Marble tiles (Baht)	Ceramic tiles (Baht)	Solid wood parquet (Baht)
Initial cost			
Materials cost	585.00	265.00	750.00
Construction cost	335.00	242.00	820.50
Future cost			
Use and maintenance cost	320,949.84	320,949.84	328,323.34
Disposal cost	220.49	66.83	-137.10
Total	322,090.33	321,523.67	329,756.74

costs and future cost, even taking into account its end-of-life sale for firewood at the end of use period. This is followed by marble tile and ceramic tiles, as shown in Table 6.

### Discussion

The study finds that ceramic tiles cause the greatest environmental impact, especially during extraction, raw material transportation and production. The production of ceramic tiles requires large volumes of several raw materials and chemicals. In terms of energy consumption, ceramic tiles consumed approximately eight times the energy requirements of marble tiles, and 16 times the production of untreated solid wood parquet tiles. Thus, if ceramic tile manufactures can reduce the volume of energy and chemical substances used in the production phase, the environmental performance of ceramic tiles will be enhanced. This is consistent with other research [18,19,20,21] indicating that the production phase of the life cycle of ceramic tiles causes the greatest environmental impact. Untreated solid wood parquet tiles are ranked second in terms of environmental impact, mainly during installation and use, due to the fact that production of untreated solid wood parquets is complicated and highly energy-intensive. Additionally, maintenance is required every 10 years.

The overall environmental impact from marble tiles is the least, with the greatest

impact arising in the production phase-blocks cutting consumes 55 % of all energy consumed throughout the cycle. This finding is consistent with similar findings by Nicoletti [19]. With regard to the four key environmental problems, marble tiles are the most environmentally friendly, and are used today in the construction of environmentally friendly buildings in Thailand.

In terms of economy, considering the total life-cycle costs of the three materials, untreated solid wood parquets incur the highest cost, especially the initial cost-one of the key factors in material selection by both contractors and consumers [8,11,12]. The life-cycle cost of untreated solid wood parquet tiles is three times that of ceramic tiles and double that of marble tiles, while the cost per m<sup>2</sup> of ceramic tiles is the lowest due to the low cost of raw materials and large economies of scale in production. As a result, ceramic tiles are the most favorable flooring material in Thailand.

Moreover, ceramic tiles are available in many designs, colors and sizes and are stronger and more durable than marble tiles, which possess low strength. Since marble is not scratch or acid-proof, marble is unsuitable for kitchen or bathroom floors, public areas. Marble is also not recommended for wet areas due to the slippery surface, or for sunlit areas. However, marble is cool and does not accumulate heat a valuable property in tropical architecture.

In regard to untreated solid wood parquets, although they cause less environmental impact than ceramic tiles, their price is higher. Additionally, they cannot be laid on a humid or wet area, and so they are suitable only for indoor use. In addition, parquet requires regular maintenance by a skilled worker. However, aesthetically, a wood floor offers a warm, natural and elegant quality to the room.

In selecting sustainable flooring materials, apart from environmental and economic coherence, other relevant factors include physical properties (e.g. weight which may affect structure size, ability to transfer heat within a building, sound absorption, reflection and flexibility of use in various building areas).

Other factors are aesthetics, variety, sales point, maintenance, familiarity and experience in using that construction material. However, these factors are abstract and many are subjective, and cannot be measured. Additionally, the popularity of any material may change with time [22,23].

Even though data are available on all aspects of construction materials, it is nevertheless difficult to identify environmentally friendly materials which have low LCC and are aesthetic and neat with physical properties fully meeting user needs [24]. In making a decision, the factors in selection of construction materials should be weighted, for example, in balancing competing needs of environment, cost, aesthetics and functionality. Nevertheless, the environmental impact values and life cycle cost of each construction material are valuable components contributing to an objective choice decision. Therefore, analysis of environmental impact and life cycle cost of construction materials should be supported more widely.

### Acknowledgement

The authors wish to thank the National Research Council of Thailand (NRCT) for financial support for this research project.

### References

- [1] Ljungberg LY. Materials Selection and Design for Development of Sustainable Products. *Materials and Design* 2007; 28(2): 466–479.
- [2] Lombera JTSJ, Rojo JC. Industrial building design stage based on a system approach to their environmental sustainability. *Construction and Building Materials* 2010; 24(4): 438–447.
- [3] Bovea MD, Gallardo A. The Influence of Impact Assessment Methods on Materials Selection for Eco-design. *Materials and Design* 2006; 27(4): 209–215.
- [4] Huang H, Liu G, Liu Z, Pan J. Multi-Objective Decision-Making of Materials Selection in Green Design. *J MechEng* 2006; 42: 131–136.
- [5] Heijungs R, Huijbregts AJM. A Review of Approaches to Treat Uncertainty in LCA. *International Environmental Modeling and Software Society*, 2004.
- [6] Grant T. Inclusion of Uncertainty in LCA. *Centre for Design at RMIT University, Melbourne*, 2009.
- [7] Huijbregts AJM. Uncertainty and Variability in Environmental Life-Cycle Assessment. PhD Thesis, University van Amsterdam, Amsterdam, 2001.
- [8] Raymond JC, Sterner E. Reconciling theory and practice of life cycle costing. *Building research and Information* 2000; 28: 368-375.

- [9] Schade J. Life cycle cost calculation models for buildings. Proceedings of 4th Nordic Conference on Construction Economics and Organisation: Development Processes in Construction Management 2007; 18: 321-329.
- [10] National Statistical Office Thailand. Report on Construction Industry Survey, [On-line], Available: <http://portal.nso.go.th>. [2011, January 23].
- [11] Lippiatt BC. Building for Environmental and Economic Sustainability Technical Manual and User Guide. Building and Fire Research Laboratory, National Institute of Standards and Technology Gaithersburg, MD, 2007. p. 99-107.
- [12] Curran MA. Building for Environmental and Economic Sustainability Peer Review Report. National Institute of Standards and Technology (NIST), USA, 2002.
- [13] Lugt P, Dobbelsteen AAJF, Janssen J.J.A. An environmental, economic and practical assessment of bamboo as a building material for supporting structures. *Construction and Building Materials* 2006; 20: 648-656.
- [14] Miettinen P, Hamalainen RP. How to Benefit from Decision Analysis in Environmental Life Cycle Assessment (LCA). *European Journal of Operational Research* 1997; 102:279-294.
- [15] International Organization for Standardization. ISO 14040: Environmental Management - Life Cycle Assessment - Principles and Framework, 2006.
- [16] International Organization for Standardization. ISO 14044: Environmental Management - Life Cycle Assessment - Requirements and Guidelines, 2006.
- [17] ASTM International Standard Classification for Building Elements and Related Sitework-UNIFORMAT II : E 1557-02. West Conshohocken, PA 19428-2959, United States, 2002.
- [18] Li X, Wang Z, Nie Z. Life Cycle Assessment of Chinese Typical Ceramic Tile. Beijing University of Technology, China, 2008.
- [19] Nicoletti GM. Comparative Life Cycle Assessment of Flooring Materials: Ceramic Versus Marble tiles. *Journal of Cleaner Production* 2002; 10(3): 283-296.
- [20] Timellini G, Palmonari C, Fregni A. Ceramic Floor and Wall Tile: An Ecological Building Material. *Tiletoday* 2005; 13(46): 18-26.
- [21] Goldoni S, Bonoli A. A Case Study About LCA of Ceramic Sector: Application of Life Cycle Analysis Results to the Environment Management System Adopted by the Enterprise. University of Bologna, Italy, 2006.
- [22] Marcus C. A practical yet meaningful approach to customer segmentation. *Journal of Consumer Marketing* 1998; 15(5): 494-504.
- [23] Bhamra T, Lilley D, Tang T. Sustainable Use: Changing Consumer Behavior Through Product Design. Proceedings of Changing the Change: Design Visions, Proposals and Tools, Turin, 2008.
- [24] Ljungberg LY, Edwards KL. Design, Materials Selection and Marketing of Successful Products. *Materials and Design* 2003; 24(7): 519-529.