



INSTITUT DE FRANCE
Académie des sciences

Comptes Rendus

Chimie

D. Duc Nguyen, Maryam Rahimi, Vahid Pirouzfard, Hossein Sakhaeinia and Chia-Hung Su

A comparative technical and economic analysis of different processes for shale gas conversion to high value products

Volume 23, issue 4-5 (2020), p. 299-314.

<https://doi.org/10.5802/crchim.30>

© Académie des sciences, Paris and the authors, 2020.
Some rights reserved.

 This article is licensed under the
CREATIVE COMMONS ATTRIBUTION 4.0 INTERNATIONAL LICENSE.
<http://creativecommons.org/licenses/by/4.0/>



Les Comptes Rendus. Chimie sont membres du
Centre Mersenne pour l'édition scientifique ouverte
www.centre-mersenne.org



Full paper / *Mémoire*

A comparative technical and economic analysis of different processes for shale gas conversion to high value products

D. Duc Nguyen^a, Maryam Rahimi^b, Vahid Pirouzfard^{*, b}, Hossein Sakhaeinia^b and Chia-Hung Su^{*, c}

^a Institute of Research and Development, Duy Tan University, Da Nang 550000, Vietnam

^b Department of Chemical Engineering, Central Tehran Branch, Islamic Azad University, Tehran, Iran

^c Department of Chemical Engineering, Ming Chi University of Technology, New Taipei City, Taiwan

E-mails: dinhduc.nguyen@kyonggi.ac.kr (D. Duc Nguyen), rahi.maryam.mi@gmail.com (M. Rahimi), v.pirouzfard@iauctb.ac.ir (V. Pirouzfard), h.sakhaeinia@iauctb.ac.ir (H. Sakhaeinia), chsu@mail.mcut.edu.tw (C.-H. Su)

Abstract. Natural gas is a clean fuel and proper feed for chemical industries. However, its transportation to consumer markets is harder and more expensive than that of crude oil because of some specific properties. Therefore, natural gas conversion to chemicals and exporting them instead of gas is safer, and this is also more profitable. Up until now, many methods and alternative techniques have been presented in this field. In this study, three important processes of shale gas conversion to more valuable compounds including gas to liquid (GTL), gas to methanol (GTM), and gas to ethylene (GTE) have been simulated by Aspen HYSYS software. Then the economic parameters of each process have been calculated. Eventually, the initial investment costs for GTM, GTL, and GTE are 422, 249, and 967, respectively. In commands allowed only within braces addition, the return on investment values for GTM, GTL, and GTE have been estimated as 40, 37, and 20%, respectively.

Keywords. Shale gas, Gas to liquid (GTL), Gas to ethylene (GTE), Gas to methanol (GTM), Economic.

Manuscript received 19th March 2020, revised 3rd May 2020, accepted 4th May 2020.

1. Introduction

Shale gas is surrounded by hard clay rocks, and it is extracted by a method known as hydraulic fracturing [1–7]. This method includes injecting a large

amount of water containing chemicals into clay structures at high pressure [8–10]. The development of new technologies to extract gas from unconventional resources in shale structures has increased the potential for gas supply, brought about many economic changes in markets, and changed demand patterns.

* Corresponding authors.

Until 1821, shale gas had been produced in small quantities from naturally fractured shales [11–15]. After the development and optimization of drilling technologies, in 1998, shale gas was produced commercially by Mitchell Energy Company from Barnett formation in Fort Worth Basin using water fracture technology [16,17].

Successes in the application of horizontal drilling, hydraulic fracturing, and microseismic technologies have been confirmed by some governments [18,19].

Two thirds of shale gas reservoirs are located in remote areas. Thus due to the difficulty in transferring natural gas to global markets as well as the low price of gas, new technologies have been developed for the conversion of natural gas to materials with higher added value and easier transportation. In addition, a huge amount of natural gas is released along with oil extraction. The cost of storage and transport of natural or associated gas is very large. In most areas, a huge amount of gas is flared, which leads to various environmental consequences. Because of these problems, natural gas conversion to materials with higher added value has become very attractive in the oil and gas industry. In comparison with coal and petroleum, natural gas is considered the largest source of energy. If there are efficient technologies for its conversion, gas resources will be more optimally exploited [20]. If scientists are able to apply economical and efficient methods for converting methane into compounds with higher added value, the large amount of gas trapped in gaseous shales will create many opportunities for investment [21]. Based on general statistics, the global market of shale gas has the potential to grow almost 5.3% (equal to \$ 9.19 billion) for commercial purposes during 2014 to 2020 [22].

At present, there are many opportunities and challenges for the conversion of shale gas to more valuable products because of massive exploration of shale gas. The main four valuable products include methanol, liquid fuels, ethylene, and propylene. Each of these products has its own conventional production methods, preservation technologies, derivatives, and uses. Al-Douri *et al.* studied different methods of converting shale gas into compounds with added value [23]. If new technologies develop and investments expand, the gas conversion will significantly reduce gas flare. One of the problems with gas con-

version has been the low price differential between feed and chemical products. But recently, the factors influencing the importance of gas conversion have changed. The increase in the volume of flare gases is undeniable. Liquid fuels have also gained a lot of credit due to them being sulfur-free [24,25]. Gradassi *et al.* studied the potential of industrial profitability of available natural gas conversion processes. They presented a basic research to calculate operating costs and initial investment for these processes. Their selected processes all required high initial investment costs. However, the payback period of the gas to methanol (GTM) conversion process has been less than that of other processes [26].

In another research, the direct conversion of shale gas to benzene has been investigated from economic, environmental, and energy-saving points of view. A sensitivity analysis of the operation condition indicates that the highest return on investment (ROI) is achieved when operating conditions of the reactor and the flash drum are ($P = 0.3$ bar, $T = 800$ °C) and ($P = 10$ bar, $T = 20$ °C), respectively. In addition, heat integration of the process reduces the CO₂ emission by 16%, which has a significant impact on environmental requirements and economic parameters [27].

The high cost of natural gas transmission from remote reserves to consumer markets has prevented the full exploitation of these reserves. Liquefied natural gas (LNG) can be transported by pipelines or ships. Nonetheless, the distribution of this liquefied gas to consumers via pipelines requires compression up to approximately 80 atm, and sometimes the pipelines to the destination may not be available. Therefore, the conversion of methane to more valuable products can make huge changes in the gas industry. Havran *et al.* realized that converting methane and carbon dioxide into more valuable chemicals is one of the new challenges facing the oil and gas industry. They described direct conversion methods of these two gases, including synthesis gas production, direct acetic acid production, photovoltaic conversion, and the dielectric barrier discharge method. They concluded that up until now, dry reforming has been the most successful method of carbon dioxide and methane conversion, which faces obstacles such as excess carbon deposition and catalyst inactivity [28].

1.1. Production of synthesis gas

Synthesis gas is a combination of carbon monoxide and hydrogen. In other words, synthesis gas is a kind of intermediate compound in the production of valuable chemicals. Companies have developed several processes to produce synthesis gas because this product is mostly utilized in the petrochemical industry.

Synthesis gas production is the most significant part of the natural gas conversion process to other materials with added value. Usually, a considerable amount of initial investment is devoted to this part [29].

There are three main methods of producing synthesis gas from natural gas:

Steam reforming reaction:

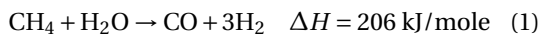

Partial oxidation reaction:

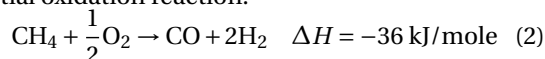

Dry reforming reaction:

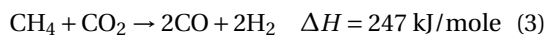

The combined use of synthesis gas production methods provides an opportunity to take advantage of each process and reduces the drawbacks of each process. For instance, autothermal reforming is a combination of steam reforming and partial oxidation reforming in which controlling the reactor temperature is easier. Furthermore, the ratio H_2/CO can be adjusted by different applications and various operating conditions [30]. In the late 1950s, Topsoe started using the ATR process to industrially produce synthesis gas in ammonia and methanol production units [31]. If low-cost oxygen is available, the ATR process will be considered a proper method for synthesis gas production [32]. Hao *et al.* simulated the gas to liquid (GTL) process by using Aspen Plus. They used a Gibbs reactor for the autothermal process and utilized a kinetic reactor for the Fischer–Tropsch process in this software [33].

1.2. Shale gas conversion to liquid

Natural gas has been recognized as the cleanest and the most available fossil fuel in the world. It is essential to convert this gas into a liquid that has less volume than gas. For this purpose, there are two main solutions: the liquefaction of natural gas and the chemical conversion of natural gas to liquid (GTL).

The GTL process involves the chemical conversion of gas to long-chain hydrocarbons, which include a wide range of transmissible and liquid fuels. Shale gas conversion takes place in the presence of catalysts such as cobalt and/or iron through Fischer–Tropsch synthesis.

In recent years, due to the great potential for the production of high-quality liquid fuels, many technical and economic studies have been conducted on gas to liquid conversions. The final products of this process are mostly equivalent to petroleum products produced in distillation towers of crude oil refineries, which are in the range of C_{10} to C_{20} compounds. They are also called middle distillate products. Other products of Fischer–Tropsch synthesis include different types of liquid fuels such as naphtha, lube oil, and wax.

The naphtha obtained from the GTL process is a suitable feed for the ethylene production unit due to its smaller cetane number than the refinery products. Due to the lack of sulfur, naphtha and kerosene obtained from GTL have a high smoke point. Saturated hydrocarbons generated from this process such as waxes and lubricants have high added value due to their high quality.

Using the Fischer–Tropsch process in GTL technology has various environmental advantages such as producing fuels with a smaller amount of sulfur compounds and NO_x and less aromatics.

Another advantage of GTL is producing enormous products as fuel with high cetane numbers (70–80). These products can be mixed with refinery products, especially diesel fuel [34]. In a case study for evaluating the GTL process, 1.16 billion Standard Cubic Feet per Day (SCFD) of natural gas was used to produce 118,000 barrels per day (bbl/d) of liquid products. Depending on the gas price, the ROI has been different. By reducing the price of gas or increasing the selling price of liquid products, the profitability of this process has increased [35,36].

1.3. Shale gas conversion to methanol

Methanol is one of the products obtained in the conversion of gas to chemicals. Methanol is an intermediate product for producing other chemical products such as acetic acid, formaldehyde, dimethyl terephthalate, methyl tert-butyl ether, etc. Regarding the potential of using shale gas for methanol

production, Laura M. Julian-Duran *et al.* provided technical, economic, and environmental analyses of the conversion process of shale gas to methanol. They investigated various synthetic gas production methods such as partial oxidation, steam reforming, autothermal reforming, and combination reforming. The results show that partial oxidation and autothermal reforming provide more financial profit for the methanol production process. From an environmental point of view, combination reforming is more acceptable; carbon emission is much lower in this alternative [37]. The first synthesis of methanol was carried out by BASF Company chemists in Luna, Germany, in 1923 [38]. Kung Harold believed that shale gas conversion to methanol using traditional and common methods was more economical than gas transportation by LNG ships [39]. Minbu Young and Fengi analyzed the profitability of shale gas economically and environmentally. They concluded that methanol production on a small scale was more economical than the common processes of shale gas conversion and enormous ranges of methanol production [40]. Ross *et al.* considered autothermal reforming as the suitable and probable method for high-capacity methanol production [41]. The role of methane in modern industries, specifically in methanol production, has been studied. Methanol is an essential feed for the synthesis of valuable products in chemical industries. Furthermore, the direct production of methanol from methane with effective oxidation of hydrogen-carbon bonds is one of the most attractive topics in the petrochemical industry [42]. In a comprehensive study, methanol production using natural gas obtained from the Brent shale has been simulated by Aspen Plus software. The results of techno-economic analysis indicate that methanol production in a wide range of selling prices of methanol and shale gas has desirable economic parameters. For example, for the selling prices of methanol and shale gas, \$2 gal and \$3.5 MMBtu, respectively, the ROI value was 31%. In addition, it became clear that the ROI would increase by approximately 2.5% after energy integration. Moreover, natural gas pre-treatment processes depend on the gas composition, which can change the feedstock price of the methanol production unit [43].

The demand of methanol to olefin (MTO) conversion has extremely increased. Jasper and Halwagi have compared the MTO and methanol

to propylene (MTP) processes in a comprehensive technical-economic analysis. They compared the use of natural gas for methanol production with the purchase of methanol. If natural gas is used as feedstock to produce methanol, more acceptable economic results will be obtained [44].

1.4. Shale gas conversion to ethylene

At present, ethylene is one of the most important and useful chemicals in the world. It has many advantages for use in the petrochemical industry. The global demand for ethylene has increased. Reportedly, 140 million tons of ethylene were produced in 2010. The importance of ethylene is due to binary bonds in its molecular structure, which increases reactivity and the ability to form chemical compounds [45]. Ethylene can be industrially converted into intermediate products. Ethylene is mainly used for conversion to light or heavy polyethylene, which is applied in industries such as construction, communication, packing, and other industrial plants [46]. Olefins such as ethylene and propylene are the most important feedstock for petrochemical units [47].

Chang He and Fengqi You investigated new methods for producing ethylene from natural gas and presented economic parameters such as net present value for each of them. They concluded that their proposed methods such as steam cracking and propane dehydrogenation have a positive effect on process efficiency and fixed investment cost in comparison with common methods of gas conversion to ethylene [48,49]. Zolfaghari *et al.* examined different methods for flare gas recovery (gas conversion to ethylene, gas to liquid, and power generation). They concluded that the flare gas conversion to ethylene has the highest annual benefit, while the ROI is lower than that of other methods [49].

Ethylene can be produced by thermal cracking of ethane and propylene that are obtained from natural gas. However, new methods such as direct methane conversion to ethylene by using catalyst reactors have been widely used. In this method, natural gas components are used to produce ethylene without initial separation [45].

Common ethylene industrial production processes include thermal cracking of ethane, naphtha and natural gas. The oxidative coupling of methane (OCM) and the methanol conversion to olefins

are among these processes. In the OCM process, methane is converted directly into ethylene in a catalytic reactor, while in the MTO process, Methane is first synthesized and then the synthesis gas is fed to methanol production reactors. Eventually, methanol is converted in a catalytic reactor into ethylene and other by-products. The economic analysis of the aforementioned methods for a certain amount of shale gas feedstock has shown that the MTO process has a higher ROI than OCM [50].

Natural gas conversion to olefins (GTO) has been introduced as one of the affordable and practical methods for chemical production. The two main products of this process are ethylene and propylene. In this process, natural gas is converted into methanol through the UOP/Hydro MTO process, and then light olefins are produced from methanol. Three methods, including the use of naphtha crackers, ethane crackers, and GTO, to produce 500,000 MM MTPA ethylene have been compared. The ROI values for the naphtha crackers, ethane cracker, and GTO are 8, 27, and 22, respectively. However, the GTO process is economical in areas where low-cost natural gas is available and has a significantly higher ROI than that of traditional methods such as naphtha cracking [51].

Regarding the above description of various recovery processes, the main purpose of this research is to present and evaluate the conventional processes of converting shale gas into valuable chemicals from a technical point of view and to compare their economic parameters in order to select the optimal and appropriate method for converting a certain volume and composition of the shale gas. Finally, the optimal process for the shale gas conversion is selected by comparing the amount of products obtained from each process, a technical review of each process's flow diagram, the equipment used per process unit and its costs, and comparison of parameters such as profit, ROI, total investment cost, etc.

2. Methods and principles

2.1. Modeling method and economic evaluation of processes

Aspen HYSYS software is one of the best simulators in chemical engineering. Aspen HYSYS v10 is used for the process simulation of shale gas conversion technologies. Then, the technical information obtained

Table 1. The composition of feed shale gas

Component	Mole percent
Methane	79.9
Ethane	11.61
Propane	3.98
Nitrogen	0.09
CO ₂	0.73
Butane	2.12
C5 ⁺	1.22
H ₂ O	0.23
H ₂ S	0.12

from each process is imported to Aspen Capital Cost Estimator software, and economic analysis is accomplished in great detail. Aspen Capital Cost Estimator is the appropriate software for preparing detailed reports on designing processes and economic evaluation related to a project.

The composition of input shale gas feed applied in each process is retrieved from the essay of Jian Gang and colleagues (Table 1) [52]. It is noteworthy that for comparing three processes of shale gas conversion correctly, the feed flow rate of each process has been considered equal to 7945 kgmol/h.

2.2. Process description

2.2.1. GTL process

The GTL process is one of the best methods for shale gas conversion to various hydrocarbons due to economic profitability and converting associated gases into eco-friendly fuels. Fischer–Tropsch synthesis products include linear and branched hydrocarbon compounds and other oxidized compounds. The main products of this synthesis are linear paraffin and alpha-olefin. In fact, Fischer–Tropsch synthesis is a catalytic process that converts synthesis gas into a combination of hydrocarbons (liquid fuels). The Fischer–Tropsch reaction can be considered as the hydrogenation of carbon monoxide, which is as follows:

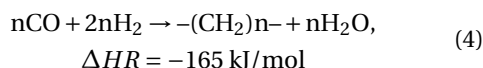

Furthermore, other reactions occur in the Fischer–Tropsch reactor. Table 2 summarizes some of the possible reactions in the reactor [53].

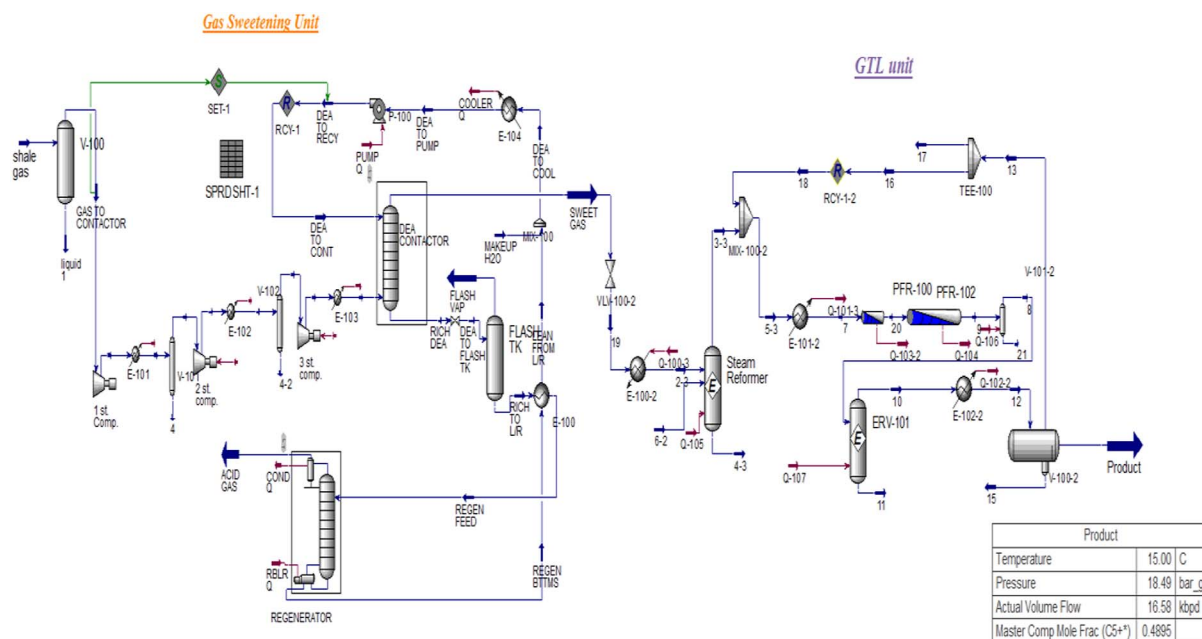

Figure 1. Process flow diagram of GTL unit.

Table 2. A number of possible reactions in F–T reactor

Reaction	ΔH_{300k} (kg/mol)
$\text{CO} + 2\text{H}_2 \rightarrow -\text{CH}_2- + \text{H}_2\text{O}$	-165.0
$2\text{CO} + \text{H}_2 \rightarrow -\text{CH}_2- + \text{CO}_2$	-204.7
$\text{CO} + \text{H}_2\text{O} \rightarrow \text{H}_2 + \text{CO}_2$	-39.8
$3\text{CO} + \text{H}_2 \rightarrow -\text{CH}_2- + 2\text{CO}_2$	-244.5
$\text{CO}_2 + 3\text{H}_2 \rightarrow -\text{CH}_2- + 2\text{H}_2\text{O}$	-125.2

Figure 1 shows the simulation of the Fischer–Tropsch process. This process includes three main stages: synthesis gas production, treatment and purification, and Fischer–Tropsch synthesis and optimization of products using common refining processes. Prior to synthesis gas production, the acid gas removal process takes place through the amine solution in the absorption and desorption columns. Since Fischer–Tropsch catalysts are sensitive to H_2S , the pre-treatment process is crucial to remove acidic gases from the feed. The next stage takes place in a steam reformer in which synthesis gas is produced by steam reforming. After cooling, the synthesis gas moves to Fischer–Tropsch reactors. Eventually, synthesis products are extracted in a separator; heavier

products are separated. The kinetic parameters and other details related to the reaction mechanism have been studied in previous research [54].

2.2.2. Methanol production process

Figure 2 demonstrates that the methanol production process from shale gas consists of four main stages: desulfurization of natural gas, steam reforming, methanol gas synthesis, and methanol purification. Since natural gas has sulfur impurities, hydrogenation of acid gases is essential. Thereby, part of the purging gases of the synthesis unit that contain a high amount of hydrogen is mixed with feed stream in the hydrogenation reactor. Then, the gas outlet from the hydrogenation reactor enters two-stage desulfurization catalytic reactors. In the first reactor, the sulfur components of gas are converted into H_2S by the cobalt–molybdenum catalyst, and in the second reactor, which includes the ZnO catalyst, the H_2S gas produced in the previous reactor is absorbed by zinc oxide. For increasing desulfurization efficiency, the inlet temperature is set as 350–400 °C. The purified gas is saturated after the temperature drops to 95 °C.

The saturated feed gas is moved to a pre-reformer after several heating stages, and heavier hydrocar-

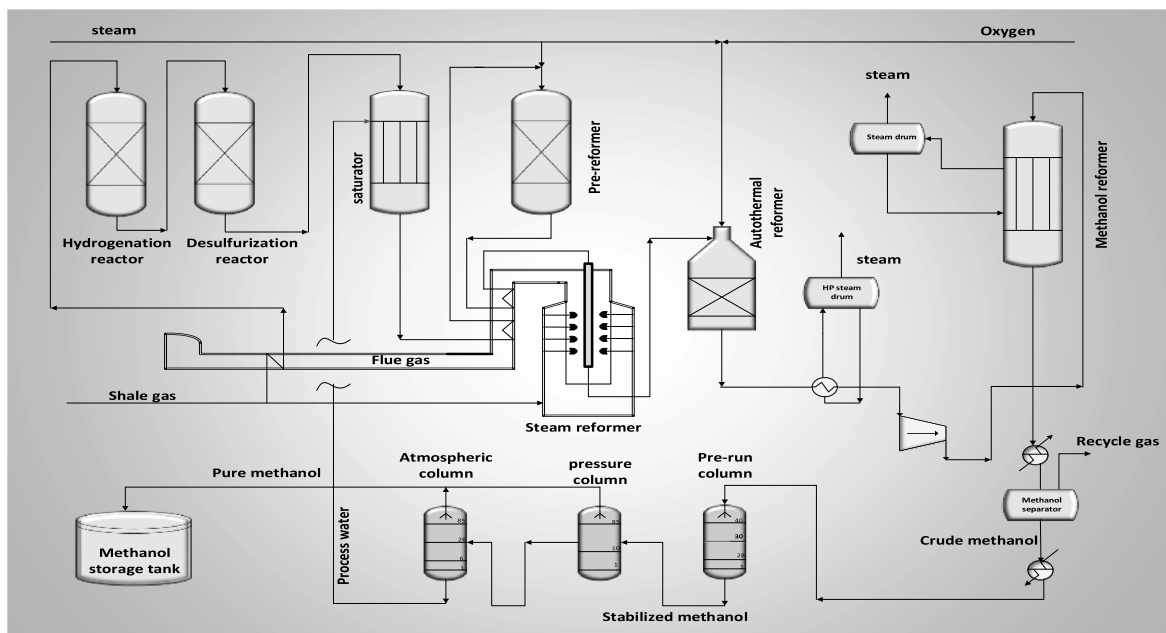
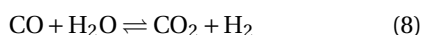
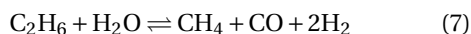
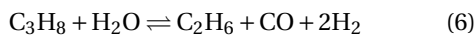
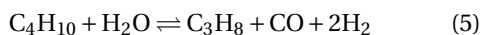
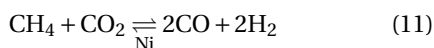
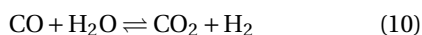
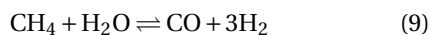

Figure 2. Block diagram of GTM unit.

bons are converted into lighter ones through the following reactions.



The feed/outlet steam from the pre-reformer at approximately 500 °C mixes with air flow in the steam reformer, and the following reaction occurs.



The exhaust gas from the steam reformer at approximately 700 °C enters the second reforming stage, called the autothermal reactor. In addition to gas, oxygen and steam are passed into this reactor. The following combined oxidation reactions occur in the presence of a nickel catalyst.

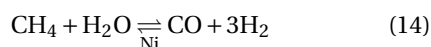
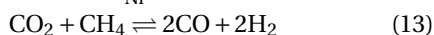
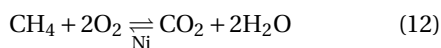

Considering the reforming reactions, the synthesis gas (CO and H₂) is produced in two stages. After some cooling steps, the temperature is reduced to 40 °C, and the synthesis gas enters the compressor. At this stage, the synthesis gas produced is compressed to 150 bar and transmitted to methanol production reactors. In the methanol synthesis reactor, this synthesis gas is converted into methanol and steam in the presence of a copper catalyst at a temperature range of 220–265 °C and pressure of 75 bar. The methanol formation reactions are as follows.

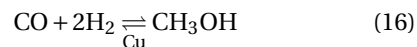
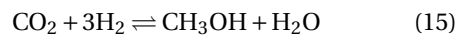

The methanol produced is associated with some dissolved gases, water, and impurities with various boiling points. These impurities are separated in a distillation unit. Finally, pure methanol and process water are obtained. Methanol distillation is implemented in three stages, including gas separation, by-product separation with a low boiling point, and separation of by-products with various boiling points. The gas separation stage occurs in a stabilizing column in which methanol pressure is reduced to approximately 2–3 bar. The dissolved gas is released. Then, crude methanol with water and dissolved gases

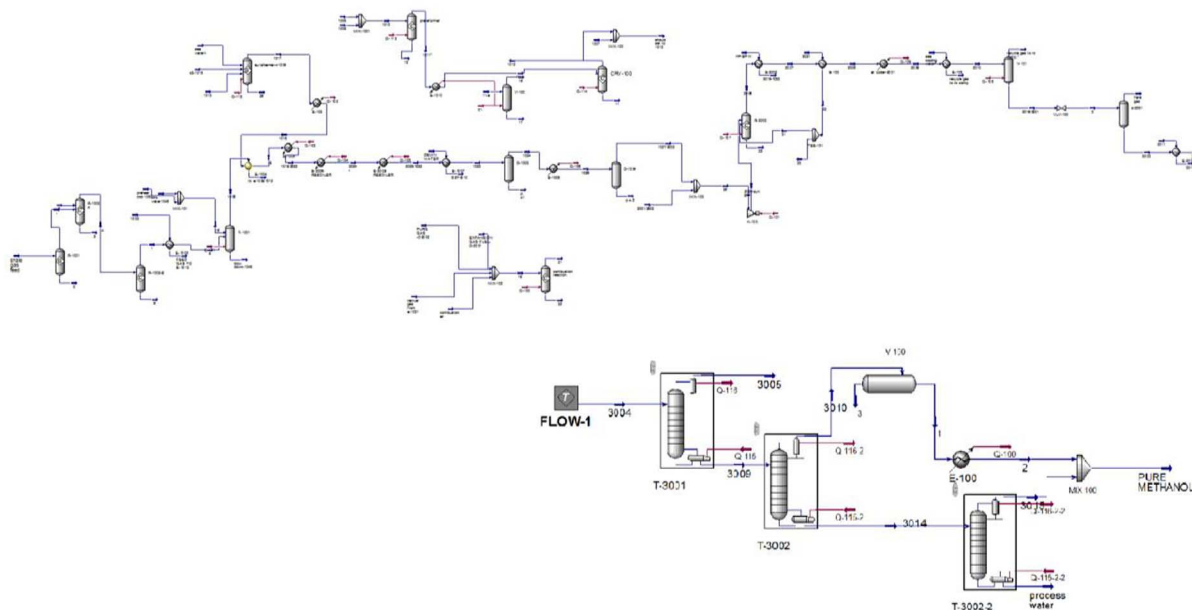

Figure 3. Process flow diagram of GTM unit.

is transmitted to the first distillation tower. The first distillation tower consists of 85 trays, and the input flow enters the 10th tray. Volatile impurities and inert gases are separated from methanol in this column. The output methanol stream from the bottom of the column, which is almost degasified, enters the second distillation column at 94 °C 2.4 bar. In the second column, methanol, water, and other heavy components are separated and the process water is removed from the bottom of the column. The output methanol vapor enters an air cooler from the top of this column at 69 °C and then passes through a heat exchanger. Consequently, its temperature decreases to 40 °C, and then it is transmitted to a reflux drum. A part of the condensed methanol is returned to the column by reflux pumps and the rest of the pure methanol is transmitted to storage tanks. Figure 3 illustrates the methanol production unit simulation in Aspen HYSYS software.

2.2.3. Ethylene production process

The direct conversion of shale gas to ethylene (GTE) has been simulated in this research (Figure 4). In this process, sweet shale gas mixture is transmitted to a thermal cracker. In this container, methane and

other hydrocarbons existing in the gas are converted into hydrogen and acetylene.

The kinetics of this mechanism are very complicated. Figure 5 shows the main reactions that occur in the cracker.

3. Discussion and results

3.1. Technical results and simulation outputs of GTL production unit

The synthesis fuels produced in the GTL process do not contain any aromatic and sulfuric compounds. GTL synthesis fuels can be considered green and clean fuels. Before simulating the Fischer–Tropsch synthesis process, a gas sweetening unit is simulated. The composition of sweet gas is presented in Table 3.

Table 4 indicates the simulation results of GTL, GTM and GTE processes. In the GTL process, the required fuel (gasoline, gasoil, and diesel) is produced from gas instead of crude oil. According to the fact that this process is considered one of the best solutions for converting shale gas into compounds with high added value.

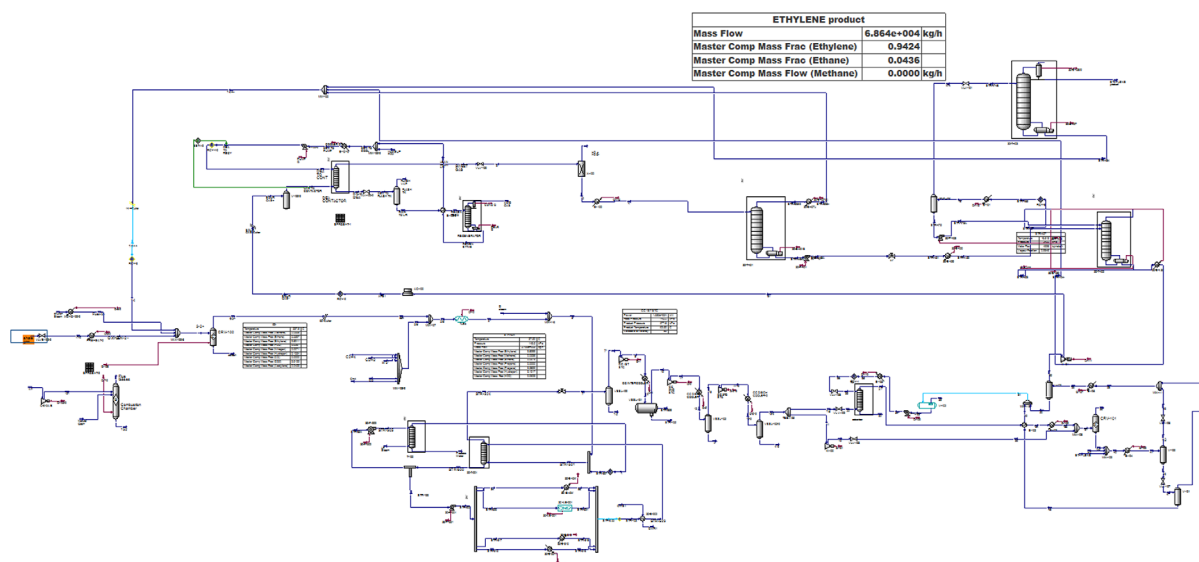

Figure 4. Process flow diagram of GTE unit.

3.2. Technical results and simulation outputs of methanol production unit

Shale gas produces less greenhouse gas than coal. As explained, the input feed gas passes through one pre-purification process including a hydrogenation reactor and desulfurization before synthesis gas production. The composition of exhaust gas from these reactors is presented in Table 7. The reduction of acidic gas can be observed after this process. After treating the input gas, it is necessary to produce synthesis gas with an appropriate ratio of H_2 and CO . The production of synthesis gas is recognized as the most fundamental part of the shale gas conversion to methanol. Simulation results including the composition of the synthesis gas in the output of the autothermal reactor and specification of pure methanol are presented in Tables 6 and 7, respectively.

3.3. Technical results and simulation outputs of ethylene production unit

Ethylene was produced by thermal cracking of ethane and propylene from shale gas. The composition of the exhaust gas from the thermal cracker is presented in Table 4. This table presents the final product specification of direct ethylene production from methane. Obviously, there is a negligible

Table 3. The composition of shale gas after sweetening in GTL process

Component	Mole fraction
Methane	0.806
Ethane	0.117
Propane	0.040
Nitrogen	0.001
CO_2	0.000
i-Butane	0.022
n-Butane	0.000
i-Pentane	0.012
n-Pentane	0.000
H_2S	0.000
H_2O	0.002
n-Hexane	0.000
CO	0.000
Hydrogen	0.000
Ethylene	0.000
C_5^+	0.000

amount of acid gas due to the purification process. Therefore, highly purified ethylene has been obtained.

Table 4. Characterizations and conditions of products from various flare recovery processes

	GTL	GTM	GTE
Conditions			
Temperature (°C)	15	85.02	−28.549
Pressure (bar)	18.49	2	19.9
Molar flow (kgmol/h)	991.1	4041	2427
Mass flow (kg/h)	6.643e+004	1.295e+005	6.864e+004
Molar enthalpy (kJ/kgmol)	−3.842e+004	−2.116e+005	3.888e+004
Molar entropy (kJ/kgmol·°C)	167.81	102.8	141.3
Heat flow (kJ/h)	−3.808e+007	−8.551e+008	9.438e+007
Mole fraction			
Methane	0.015	0.000	0.056
Ethane	0.048	0.000	0.060
Ethylene	0.004	0.000	0.321
Propane	0.217	0.000	0.292
i-Butane	0.080	0.000	0.000
n-Butane	0.052	0.000	0.046
i-Pentane	0.079	0.000	0.000
n-Pentane	0.008	0.000	0.027
n-Hexane	0.000	0.000	0.007
M-Mercaptan	0.000	0.000	0.000
E-Mercaptan	0.000	0.000	0.000
H ₂ S	0.000	0.000	0.000
Nitrogen	0.001	0.000	0.001
Hydrogen	0.004	0.000	0.105
H ₂ O	0.000	0.001	0.027
CO	0.003	0.000	0.000
CO ₂	0.000	0.000	0.012
Methanol	0.000	0.999	0.000
C5 ⁺	0.489	0.000	0.000

3.4. The economic analysis of the processes

The results of the process simulation were imported to the Icarus software to economically evaluate the gas conversion processes. Effective factors of the total costs include all direct and indirect costs, operational costs, feedstock cost, and the market prices of GTL, methanol, and ethylene.

The total investment for the production of 1100 barrels of GTL per day was calculated. In addition, the production costs of 162 m³/h of

methanol and 1838 m³/h of ethylene were calculated (Tables 5–8). For comparing these processes, their important economic parameters were calculated according to Figure 6.

According to Figure 7, the GTM process has the highest ROI. To provide an accurate economic comparison, the feedstock flow is set equal for the three processes. The sales revenue of ethylene and methanol is higher. Additionally, it can be seen that the difference between the RORs of GTM and GTL is not great (Figure 8). As a result, for converting shale

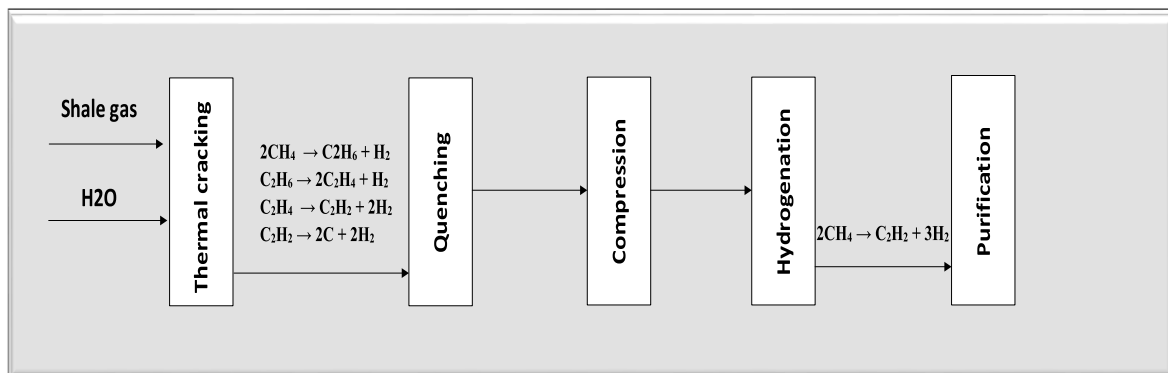

Figure 5. Schematic of the GTL process.

Table 5. Cost summary of GTL process unit project

GTL project cost summary								
Account	Key qty	Unit MH	MH	Wage rate	Labor cost	Unit matl	Matl cost	Total cost
Equipment	18 item(s)	622.30	11,201.00	43.07	482,441	3,233,167	58,197,000	58,679,441
AG pipe	1935 M	15.00	29,012.00	42.57	1,235,121	2,108	4,078,790	5,313,911
Concrete	906 M3	9.5	8,643	33.79	292,014	288.29	261,219	553,233
Grout	3.3 M3	163.1	540.00	32.37	17,472	4,255	14,084	31,556
Steel	21.6 tons	46.30	998.00	39.51	39,440	8,919	192,364	231,804
Instrumentation	355 each	18.00	6,404.00	42.83	274,291	2,545	903,508	1,177,799
UG electrical	597 M	0.94	559.00	37.44	20,933	18.79	11,222	32,155
AG electrical	15771 M	0.50	7,853.00	41.46	325,579	62.76	989,715	1,315,293
Pipe insulation	1760 M	1.80	3,221.00	32.00	103,062	72.31	127,293	230,355
Equip insulation	935 M2	2.90	2,715.00	31.90	86,619	61.54	57,566	144,185
Paint	8331 M2	0.46	3,850.00	31.48	121,204	6.00	50,022	171,227
Direct totals	-	-	74,996.00		2,998,175	-	-	67,880,959
Const equip & indirects	-	-	-	-	-	-	-	2,522,300
Const mgt, staff, supv	-	-	10,900.00	-	-	-	-	1,263,600
Engineering	-	-	28,361.00	-	-	-	-	3,523,800
Other project costs	-	-	1,516.00	-	-	-	-	4,431,686
Contingency	-	-		-	-	-	-	11,943,352
Indirect totals	-	-	40,777.00	-	-	-	-	23,684,738
Project totals	-	-	115,773.00	-	2,998,175	-	-	91,565,696

gas feed with this capacity, methanol production is a more appropriate process. Since most of the methanol production cost is allocated to feed, the

production of methanol in regions with cheaper feed such as shale gas can provide investment opportunity as well as profitability.

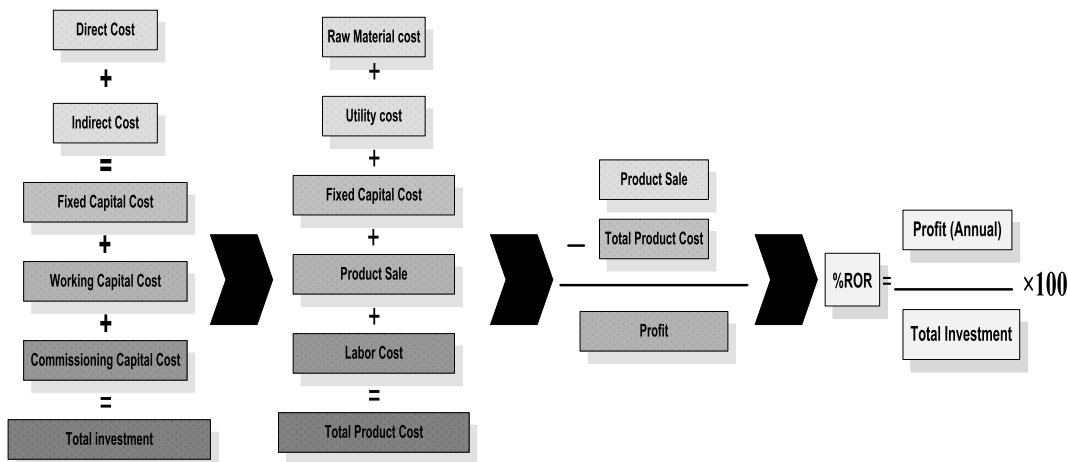

Figure 6. Stages of calculating economic parameters.

Table 6. Cost summary of GTM process unit project

GTL project cost summary								
Account	Key qty	Unit MH	MH	Wage rate	Labor cost	Unit matl	Matl cost	Total cost
Equipment	30 item(s)	736.20	22,085	4,304.00	950,615	275,889	82,766,900	83,717,515
AG pipe	3509M	46.80	164,145	42.80	7,025,903	3,060	10,736,340	17,762,243
Concrete	1912 M3	11.00	21,068	34.09	718,150	308	588,422	1,306,572
Grout	9.2 M3	140.80	1,301	32.37	42,114	4,271	39,468	81,582
Steel	49.1 tons	45.50	2,235	39.51	88,303	8,857	435,228	523,531
Instrumentation	486 each	14.40	7,002	42.75	299,356	2,991	1,453,428	1,752,783
UG electrical	909 M	85.00	775	37.30	28,895	17	15,750	44,645
AG electrical	9631 M	65.00	6,249	41.40	258,734	64	618,050	876,784
Pipe insulation	4289 M	2.30	9,872	32.00	315,903	95	408,264	724,167
Equip insulation	7387 M2	3.20	23,749	31.90	757,612	61	447,137	1,204,749
Paint	14181 M2	0.51	7,178	31.60	226,809	6	90,137	316,947
Direct totals			265,660		10,712,395			108,311,518
Const equip & indirects	-	-	-	-	-	-	-	8,885,402
Const mgt, staff, supv	-	-	37,560	-	-	-	-	4,345,001
Engineering	-	-	42,158	-	-	-	-	5,241,401
Other project costs	-	-	6,322	-	-	-	-	8,272,397
Contingency	-	-	-	-	-	-	-	20,258,356
Indirect totals			86,040					47,002,557
Project totals	-	-	351,700	-	10,712,395	-	97,599,123	155,314,075

On the other hand, the high demand for diesel production can be met by the GTL method although this method is costly for refineries. If clean fuel pro-

duction is considered, the GTL method is a good option. It can be observed that ethylene production has the lowest ROI, and its initial investment cost

Table 7. Cost summary of GTE process unit project

GTL project cost summary								
Account	Key qty	Unit MH	MH	Wage rate	Labor cost	Unit matl	Matl cost	Total cost
Equipment	50 ITEM(S)	995.20	49,761.00	43.16	2,147,816.00	463,988.00	231,994,300	234,142,116
AG pipe	5224 M	28.70	149,957.00	42.73	6,407,156.00	2,290.00	11,964,805	18,371,961
Concrete	4323 M3	10.10	43,672.00	34.15	1,491,549.00	296.97	1,283,942	2,775,490
Grout	12.3 M3	146.40	1,803.00	32.37	58,350.00	4,269.00	52,548	110,898
Steel	71.6 tons	45.90	3,287.00	39.51	129,857.00	8,892.00	636,252	766,109
Instrumentation	884 each	17.00	15,057.00	42.82	644,699.00	2,432.00	2,149,998	2,794,697
UG electrical	1503 M	0.80	1,198.00	37.15	44,493.00	16.35	24,583	69,076
AG electrical	34620 M	0.52	17,931.00	41.42	742,775.00	53.82	1,863,138	2,605,913
Pipe insulation	5349 M	2.10	11,444.00	31.68	362,567.00	110.45	590,838	953,405
Equip insulation	11824 M2	2.00	23,229.00	31.41	729,726.00	44.98	531,840	1,261,567
Paint	20376 M2	47.00	9,648.00	31.51	303,978.00	6.13	124,867	428,846
Direct totals			326,986.00		13,062,966.00		251,217,111	264,280,077
Const equip & indirects	-	-		-	-	-	-	10,966,303
Const mgt, staff, supv	-	-	53,733.00	-	-	-	-	6,181,701
Engineering	-	-	66,115.00	-	-	-	-	8,217,002
Other project costs	-	-	9,800.00	-	-	-	-	17,147,746
Contingency	-	-		-	-	-	-	46,018,920
Indirect totals			129,648.00					88,531,672
Project totals	-	-	456,634.00	-	10,712,395.00	-	251,217,111	352,811,748

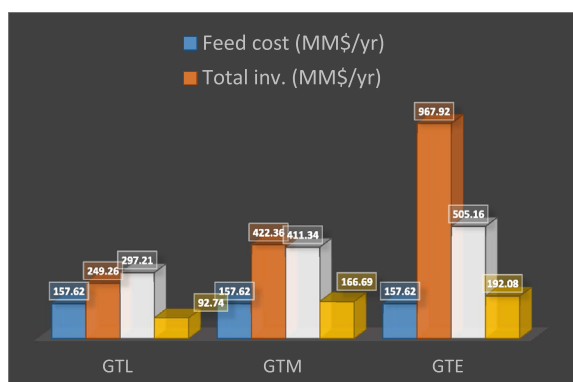
**Figure 7.** A comparison among product sales, total investment, feed cost, and profit.

is greater than that of the other two methods. By comparing purchase and installation costs of equipment in each process, it can be realized that these parameters in the GTE process are higher than those

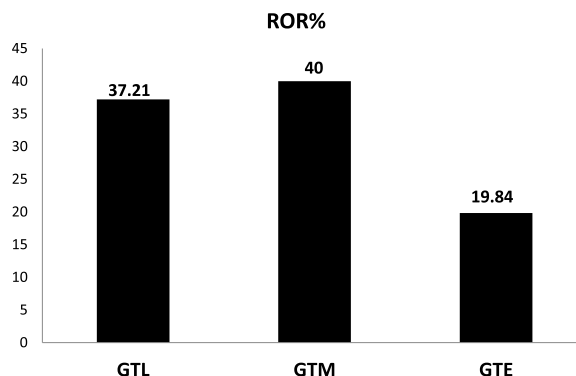
**Figure 8.** A comparison of rate of return.

in the other two processes due to greater complexity and more expensive equipment, such as cold box and compressors, than those of the ethylene production process. According to the fact that the ethylene production method is more complicated than other

Table 8. Summary of economic parameters, advantages and disadvantages of processes for shale gas conversion

Process	GTL	GTM	GTE
Direct cost (MM\$/YR)	74.67	119.14	294.01
Indirect cost (MM\$/YR)	26.05	51.70	97.38
Fixed capital cost (MM\$/YR)	100.72	170.85	391.39
Working capital cost (MM\$/YR)	37.74	63.58	146.00
Start-up capital cost (MM\$/YR)	10.07	17.08	39.14
Total investment (MM\$/YR)	249.26	422.36	967.92
Raw material cost (MM\$/YR)	157.62	157.62	157.62
Utility cost (MM\$/YR)	16.79	28.47	65.23
Labor cost (MM\$/YR)	3.30	11.78	14.37
Revenue (MM\$/YR)	297.21	411.34	505.16
Total product cost (MM\$/YR)	204.47	244.65	313.08
Profit	92.74	166.69	192.08
ROR	37.21	40	19.84
Advantage	Products without sulfur and aromatic contamination Suitable for areas water is not available	Best economic parameters (ROR, profit) Highly used in many industries Used as feed in other petrochemical units	Highly used in many industries
Limitations	This process at low gas prices is economical Low profitability relative to investment cost	-	Complex process and equipment Need a high total investment Lowest ROR than other processes

methods and by comparing the calculated economic parameters, it can be concluded that GTE is not economical for this capacity of shale gas.

4. Conclusion

As mentioned earlier, in this research, three different methods of shale gas conversion into valuable chemicals were investigated. In addition, these methods were compared from technical and economic points of view. The technical and economic results indicate that shale gas conversion to methanol is more appropriate than other methods. Besides the additional complexities in the ethylene industrial process, the ROI or ROR and the total investment for the GTE process are 19.84% and 967.92 MM\$, respectively.

Hence the highest total investment cost and the lowest ROR belong to this process (Figures 7 and 8). The initial investment cost required for GTM is 422.355 MM\$, while it costs 249.248 MM\$ for the GTL process. Despite the higher investment in the methanol production process, the ROR of this process is more favorable than the GTL process. It should be considered that the GTL process is costly and is only economically beneficial if the price of the input feed gas is low. Furthermore, the results indicate that the annual benefits obtained from GTM and GTL processes are 166.69 and 92.74, respectively. This reveals high profitability of the methanol production process even though its investment cost is higher. The production of methanol, which is one of the most useful chemicals in the oil and gas industry,

could be a suitable option for shale gas conversion due to a less complex process and better economic parameters than other methods.

Nomenclature

GTL	gas to liquid
GTE	gas to ethylene
GTM	gas to methanol
F–T	Fischer–Tropsch
ROI	return on investment
ROR	rate of return
supv	supervisory
Const mgt	Construction management
inv.	investment

References

- [1] D. Allam, S. Bennici, L. Limousy, S. Hocine, “Improved Cu- and Zn-based catalysts for CO₂ hydrogenation to methanol”, *C. R. Chim.*, 2019, **22**, 227-237.
- [2] C. Brabant, A. Khodakov, A. Griboval-Constant, “Promotion of lanthanum-supported cobalt-based catalysts for the Fischer-Tropsch reaction”, *C. R. Chim.*, 2017, **20**, 40-46.
- [3] S. Khorramshokouh, V. Pirouzfard, Y. Kazerouni, A. Fayyazbakhsh, R. Abedini, “Improving the properties and engine performance of diesel-methanol-nanoparticle blend fuels via optimization of the emissions and engine performance”, *Energy Fuels*, 2016, **30**, 8200-8208.
- [4] K. Kobl, L. Angelo, Y. Zimmermann, S. Sall, K. Parkhomenko, A.-C. Roger, “In situ infrared study of formate reactivity on water-gas shift and methanol synthesis catalysts”, *C. R. Chim.*, 2015, **18**, 302-314.
- [5] V. Pirouzfard, A. Zarringhalam Moghaddam, B. Mirza, “Physicochemical properties and combustion performance of gas oil-fuel additives”, *ASME. J. Energy Resour. Technol.*, 2012, **134**, no. 4, article ID 041101.
- [6] S. Saleh, V. Pirouzfard, A. Alihosseini, “Performance analysis and development of a refrigeration cycle through various environmentally friendly refrigerants”, *J. Therm. Anal. Calorimet.*, 2019, **136**, 1817-1830.
- [7] C. Sun, Y. Wang, Z. Wang, H. Chen, X. Wang, H. Li, L. Sun, C. Fan, C. Wang, X. Zhang, “Fabrication of hierarchical ZnSAPO-34 by alkali treatment with improved catalytic performance in the methanol-to-olefin reaction”, *C. R. Chim.*, 2018, **21**, 61-70.
- [8] M. Jamshidi, V. Pirouzfard, R. Abedini, M. Z. Pedram, “The influence of nanoparticles on gas transport properties of mixed matrix membranes: An experimental investigation and modeling”, *Korean J. Chem. Eng.*, 2017, **34**, 829-843.
- [9] E. Kianfar, M. Salimi, V. Pirouzfard, B. Koohestani, “Synthesis of modified catalyst and stabilization of CuO/NH₄-ZSM-5 for conversion of methanol to gasoline”, *Int. J. Appl. Ceram. Technol.*, 2018, **15**, 734-741.
- [10] M. Salimi, V. Pirouzfard, E. Kianfar, “Enhanced gas transport properties in silica nanoparticle filler-polystyrene nanocomposite membranes”, *Colloid Polym. Sci.*, 2017, **295**, 215-226.
- [11] S. Heydari, V. Pirouzfard, “The influence of synthesis parameters on the gas selectivity and permeability of carbon membranes: empirical modeling and process optimization using surface methodology”, *RSC Adv.*, 2016, **6**, 14149-14163.
- [12] V. Pirouzfard, M. Omidkhan, “Mathematical modeling and optimization of gas transport through carbon molecular sieve membrane and determining the model parameters using genetic algorithm”, *Iran. Polym. J.*, 2016, **25**, 203-212.
- [13] M. Salimi, V. Pirouzfard, E. Kianfar, “Novel nanocomposite membranes prepared with PVC/ABS and silica nanoparticles for C₂H₆/CH₄ separation”, *Polym. Sci. Ser. A*, 2017, **59**, 566-574.
- [14] S. F. Soleymanipour, A. H. S. Dehaghani, V. Pirouzfard, A. Alihosseini, “The morphology and gas-separation performance of membranes comprising multiwalled carbon nanotubes/polysulfone-Kapton”, *J. Appl. Polymer Sci.*, 2016, **133**, article ID 43839.
- [15] H. Zhou, S. Yang, H. Xiao, Q. Yang, Y. Qian, L. Gao, “Modeling and techno-economic analysis of shale-to-liquid and coal-to-liquid fuels processes”, *Energy*, 2016, **109**, 201-210.
- [16] Z. Wang, A. Krupnick, “A retrospective review of shale gas development in the United States: What led to the boom?”, *Econ. Energy Environ. Policy*, 2015, **4**, 5-18.
- [17] J. Sirola, “The impact of shale gas in the chemical industry”, *AIChEJ.*, 2014, **60**, 810-819.
- [18] w. D. Drilling, https://en.wikipedia.org/wiki/Directional_drilling.
- [19] N. Warpinski, “Microseismic monitoring: Inside and out”, *J. Petrol. Technol.*, 2009, **61**, 80-85.
- [20] C. A. Jones, J. J. Leonard, J. A. Sofranko, “Fuels for the future: remote gas conversion”, *Energy Fuels*, 1987, **1**, 12-16.
- [21] J. N. Armor, “Emerging importance of shale gas to both the energy & chemicals landscape”, *J. Energy Chem.*, 2013, **22**, 21-26.
- [22] A. Galadima, O. Muraza, “Revisiting the oxidative coupling of methane to ethylene in the golden period of shale gas: A review”, *J. Ind. Eng. Chem.*, 2016, **37**, 1-13.
- [23] A. Al-Douri, D. Sengupta, M. El-Halwagi, “Shale gas monetization—A review of downstream processing to chemicals and fuels”, *J. Nat. Gas Sci. Eng.*, 2017, **45**, 436-455.
- [24] D. A. Wood, C. Nwaoha, B. F. Towler, “Gas-to-liquids (GTL): A review of an industry offering several routes for monetizing natural gas”, *J. Nat. Gas Sci. Eng.*, 2012, **9**, 196-208.
- [25] K. Aasberg-Petersen, J.-H. B. Hansen, T. Christensen, I. Dybkjaer, P. S. Christensen, C. S. Nielsen, S. W. Madsen, J. Rostrup-Nielsen, “Technologies for large-scale gas conversion”, *Appl. Catal. A: General*, 2001, **221**, 379-387.
- [26] M. J. Gradassi, N. W. Green, “Economics of natural gas conversion processes”, *Fuel Process. Technol.*, 1995, **42**, 65-83.
- [27] S. I. Pérez-Uresti, J. M. Adrián-Mendiola, M. M. El-Halwagi, A. Jiménez-Gutiérrez, “Techno-economic assessment of benzene production from shale gas”, *Processes*, 2017, **5**, 33.
- [28] V. Havran, M. P. Duduković, C. S. Lo, “E.C. Research, Conversion of methane and carbon dioxide to higher value products”, *Industrial & Engineering Chemistry Research*, 2011, **50**, no. 12, 7089-7100.

- [29] S. S. Bharadwaj, L. D. Schmidt, "Catalytic partial oxidation of natural gas to syngas", *Fuel Processing Technology*, 1995, **42**, no. 23, 109-127.
- [30] M. M. Noureldin, N. O. Elbashir, M. M. J. I. El-Halwagi, E.C. Research, Optimization and selection of reforming approaches for syngas generation from natural/shale gas, 2013, **53**, 1841-1855.
- [31] H. T. A/S, S. B. de l'Azote, Hydrocarbon Process, 1988, **67**, 77.
- [32] J. Rostrup-Nielsen, I. Dybkjaer, L. J. Christiansen, "Steam reforming opportunities and limits of the technology", in *Chemical Reactor Technology for Environmentally Safe Reactors and Products*, Springer, 1992, 249-281.
- [33] X. Hao, M. E. Djatmiko, Y. Xu, Y. Wang, J. Chang, Y. Li, "Simulation analysis of a GTL process using ASPEN plus", *Chem. Eng. Technol.: Ind. Chem.-Plant Equip.-Process Eng.-Biotechnol.*, 2008, **31**, 188-196.
- [34] B. Bao, M. M. El-Halwagi, N. O. J. F. P. T. Elbashir, "Simulation, integration, and economic analysis of gas-to-liquid processes", *Fuel Processing Technology*, 2010, **91**, 703-713.
- [35] B. Bao, M. M. El-Halwagi, N. O. Elbashir, "Simulation, integration, and economic analysis of gas-to-liquid processes", *Fuel Process. Technol.*, 2010, **91**, 703-713.
- [36] A. Hoek, "The Shell GTL process: towards a world scale project in qatar", *Chem. Ingenieur Technik*, 2005, **77**, 1172-1172.
- [37] L. M. Julián-Durán, A. P. Ortiz-Espinoza, M. M. El-Halwagi, A. J. A. S. C. Jiménez-Gutiérrez, "Engineering, Techno-economic assessment and environmental impact of shale gas alternatives to methanol", *ACS Sustain. Chem. Eng.*, 2014, **2**, 2338-2344.
- [38] P. Tjijm, F. Waller, D. J. A. C. A. G. Brown, "Methanol technology developments for the new millennium", *Appl. Catal. A: General*, 2001, **221**, 275-282.
- [39] H. H. Kung, *Methanol Production and Use Chemical Industries, Volume 57*, CRC Press, 1994.
- [40] M. Yang, F. J. A. J. You, "Modular methanol manufacturing from shale gas: Techno-economic and environmental analyses of conventional large-scale production versus small-scale distributed, modular processing", *AIChE J.*, 2018, **64**, 495-510.
- [41] J. Ross, A. Van Keulen, M. Hegarty, K. J. C. T. Seshan, The catalytic conversion of natural gas to useful products, 1996, **30**, 193-199.
- [42] A. Caballero, P. J. J. C. S. R. Pérez, "Methane as raw material in synthetic chemistry: The final frontier", *Chem. Soc. Rev.*, 2013, **42**, 8809-8820.
- [43] V. M. Ehlinger, K. J. Gabriel, M. M. Noureldin, M. M. El-Halwagi, "Process design and integration of shale gas to methanol", *ACS Sustain. Chem. Eng.*, 2014, **2**, 30-37.
- [44] S. Jasper, M. M. El-Halwagi, "A techno-economic comparison between two methanol-to-propylene processes", *Processes*, 2015, **3**, 684-698.
- [45] K. R. J. C. t. Hall, "A new gas to liquids (GTL) or gas to ethylene (GTE) technology", *Catal. Today*, 2005, **106**, 243-246.
- [46] A. A. Abedi, *Economical Analysis of a New Gas to Ethylene Technology*, Texas A&M University, 2007.
- [47] S. S. Haghghi, M. Rahimpour, S. Raeissi, O. J. C. E. J. Dehghani, "Investigation of ethylene production in naphtha thermal cracking plant in presence of steam and carbon dioxide", *Chem. Eng. J.*, 2013, **228**, 1158-1167.
- [48] C. He, F. J. I. You, "E.C. Research, Shale gas processing integrated with ethylene production: novel process designs, exergy analysis, and techno-economic analysis", *Industrial & Engineering Chemistry Research*, 2014, **53**, 11442-11459.
- [49] M. Yang, F. J. I. You, "E.C. Research, Comparative techno-economic and environmental analysis of ethylene and propylene manufacturing from wet shale gas and naphtha", *Industrial & Engineering Chemistry Research*, 2017, **56**, 4038-4051.
- [50] A. P. Ortiz-Espinoza, M. M. Noureldin, M. M. El-Halwagi, A. Jiménez-Gutiérrez, "Design, simulation and techno-economic analysis of two processes for the conversion of shale gas to ethylene", *Comput. Chem. Eng.*, 2017, **107**, 237-246.
- [51] B. Vora, T. Marker, P. Barger, H. Nilsen, S. Kvisle, T. Fuglerud, "Economic route for natural gas conversion to ethylene and propylene", *Stud. Surf. Sci. Catal.*, 1997, **107**, 87-98.
- [52] J. Gong, F. J. C. E. T. You, "Handling uncertain feedstock compositions in shale gas processing system designs with simulation-based robust equipment capacities", *Chem. Eng. Trans.*, 2017, **61**, 145-150.
- [53] Y. H. Kim, K.-W. Jun, H. Joo, C. Han, I. K. J. C. E. J. Song, "A simulation study on gas-to-liquid (natural gas to Fischer-Tropsch synthetic fuel) process optimization", *Chem. Eng. J.*, 2009, **155**, 427-432.
- [54] M. Zolfaghari, V. Pirouzfard, H. J. E. Sakhaeinia, "Technical characterization and economic evaluation of recovery of flare gas in various gas-processing plants", *Energy J.*, 2017, **124**, 481-491.