

**Bukti Korespondensi Publikasi Artikel**  
**International Journal on Smart Sensing and Intelligent Systems**

Artikel disubmit pada tanggal **20 April 2022** dengan judul: **“A Portable Device Based on an Electrical Conductivity Sensor for the Detection of Monosodium Glutamate (MSG) in Soupy Foods”**.

Selanjutnya, pada tanggal 19 Mei 2022 artikel kami mendapat Revisi/Perbaikan dari reviewer. Berdasarkan saran reviewer, kami telah melakukan perbaikan dan submit ulang artikel yang telah kami perbaiki. Berikut rangkuman korespondensi dari artikel kami dapat dilihat pada tabel 1.

**Tabel 1.** Bukti korespondensi

Tanggal	Korespondensi		Hal
	Author	Editor Jurnal	
20 April 2022	Artikel disubmit melalui editor manager jurnal dengan judul: <b>“A Portable Device Based on an Electrical Conductivity Sensor for the Detection of Monosodium Glutamate (MSG) in Soupy Foods”</b> . Pada sistem OJS.  (lampiran 1. Bukti submit OJS)		2
11 Juli 2022		Email keputusan editor bahwa artikel kami mendapatkan revisi  (Lampiran 2. Bukti email)	3
18 Agustus 2022		Email reminder dari editor bahwa artikel kami telah melebihi batas waktu revisi dari reviewer  (Lampiran 3. Bukti email reminder dari editor)	3
19 September 2022		Email dari editor tentang former letter  (Lampiran 4. Bukti email)	4
22 September 2022	Email meminta permohonan maaf dari author ke editor bahwa kami belum mengembalikan artikel revisi ke editor  Lampiran 5. Bukti email permohonan maaf)		4
22 September 2022		Email balasan dari editor bahwa artikel revisi masih ditunggu oleh editor  (Lampiran 6. Bukti email respon dari editor)	5
1 Agustus 2022		Email dari editor bahwa artikel kami telah di terima dan masuk ke galley proof  (Lampiran 7. Bukti email editor)	5
9 Agustus 2022		Email dari editor bahwa artikel kami akan terbit di issue terakhir  Lampiran 8. Bkti email editor)	6

18 Agustus 2022		<p>Email dari editor bahwa artikel kami sudah terbit di I2M pada volume 21, Number 3, 2022.</p> <p>Please cek link;  <a href="https://www.iieta.org/journals/i2m/paper/10.18280/i2m.210305">https://www.iieta.org/journals/i2m/paper/10.18280/i2m.210305</a></p> <p>(Lampiran 9. Bukti email editor)</p>	6
-----------------------	--	--------------------------------------------------------------------------------------------------------------------------------------------------------------------------------------------------------------------------------------------------------------------------------------------------------------	---

Lampiran 1

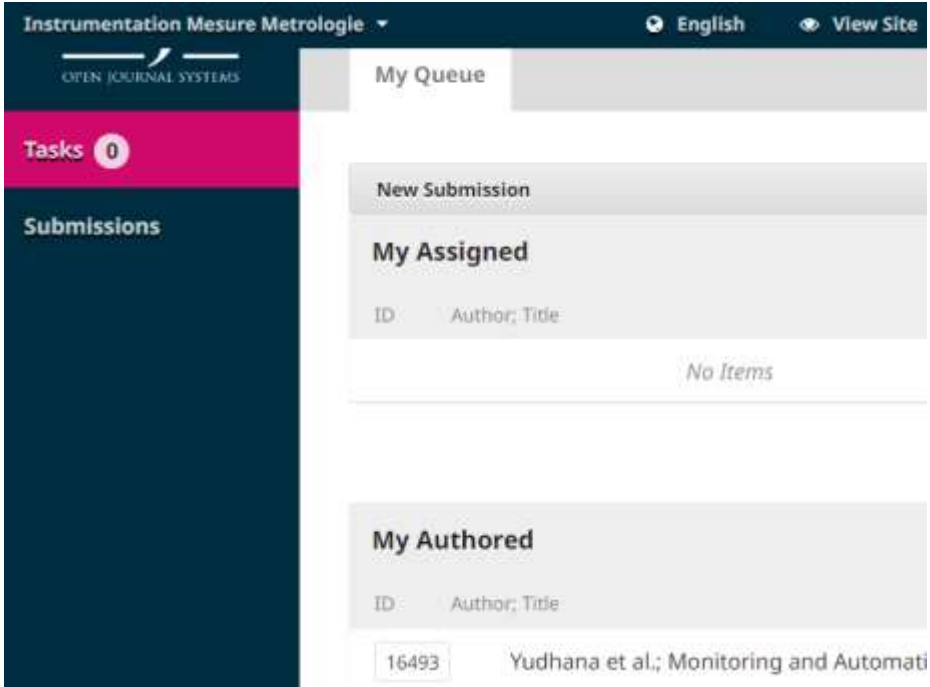

## Lampiran 2

[editor.i2m@iieta.org](mailto:editor.i2m@iieta.org) <[editor.i2m@iieta.org](mailto:editor.i2m@iieta.org)>

Lampiran

Sen, 11 Jul 14:08

kepada saya

Terjemahkan pesan

Nonaktifkan untuk: Inggris

Dear author,

Thank you for contributing your paper to INSTRUMENTATION MESURE MÉTROLOGIE!

Please revise your paper according to the attached comments.

Highlight the revised parts in the final version of your paper and give a response according to review comments.

Please typeset your paper according to template.

To ensure fast publication of your paper, please return your revised manuscript and answers to all queries to this email before July 17, 2022. Thus, we have enough time to process your manuscript in the next step. For further assistance, please do not hesitate to contact us via this email.

---

## Lampiran 3

imel berikutnya : **18 Agustus 2022**



[editor.i2m@iieta.org](mailto:editor.i2m@iieta.org) <[editor.i2m@iieta.org](mailto:editor.i2m@iieta.org)>

Lampiran

18 Agu 2022 10:37

kepada saya

Terjemahkan pesan

Nonaktifkan untuk: Inggris

Dear author,

Thank you for contributing your paper to INSTRUMENTATION MESURE MÉTROLOGIE!

Please revise your paper according to the attached comments.

Highlight the revised parts in the final version of your paper and give a response according to review comments.

Please typeset your paper according to template.

To ensure fast publication of your paper, please return your revised manuscript and answers to all queries to this email before August 26, 2022. Thus, we have enough time to process your manuscript in the next step. For further assistance, please do not hesitate to contact us

#### Lampiran 4

**19 September 2022**

editor.i2m iieta.org <editor.i2m@iieta.org>

Lampiran

19 Sep 2022 15.59

kepada saya

Terjemahkan pesan  
Nonaktifkan untuk: Inggris  
Dear author,

Hope this email finds you well!

Have you received the former letter? Please let us know your willing for further processing of your manuscript.

Kind regards

#### Lampiran 5.

Anton Yudhana <eyudhana@ee.uad.ac.id>

22 Sep 2022 07.36

kepada editor.i2m

Dear Editor,

Please accept my big apologies for my late response. We are still interested in further processing the manuscript. We will continue the revision as the reviewer comments.

Best regards,

Anton Yudhana

Pada tanggal Sen, 19 Sep 2022 pukul 15.59 editor.i2m iieta.org

<editor.i2m@iieta.org> menulis:

Dear author,

Hope this email finds you well!

Have you received the former letter? Please let us know your willing for further processing of your manuscript.

## Lampiran 6.

22 September 2022



editor.i2m iieta.org <editor.i2m@iieta.org>  
22 Sep 2022 15.41  
kepada saya

Terjemahkan pesan  
Nonaktifkan untuk: Inggris  
Dear author,

Thanks for your reply.

We are waiting for receiving the revised files from you

Kind regards

## Lampiran 7

\* 1 Agustus 2022\*

Galley proof of your paper submitted to I2M!  
Eksternal  
Kotak Masuk

editor.i2m iieta.org <editor.i2m@iieta.org>  
Lampiran  
Sen, 1 Agu 16.04  
kepada saya

Terjemahkan pesan  
Nonaktifkan untuk: Inggris  
Dear author,

Thank you for contributing your paper to INSTRUMENTATION MESURE MÉTROLOGIE!

Please revise your paper with particular reference to the following points:

1. Please revise your paper according to the attached template.

## Lampiran 8.

Sel, 9 Agu 09.11  
kepada saya

Terjemahkan pesan  
Nonaktifkan untuk: Inggris  
Dear author,

Hope this email finds you well!

Have you received the former letter?

Please return the revised files ASAP, thus your paper can be published in the latest issue.

Kind regards,

Editorial Board

## Lampiran 9.

**18 Agustus 2022**

Your paper has been published in I2M (Vol. 21, No. 3, 2022)!

Eksternal  
Kotak Masuk

[editor.i2m@iieta.org](mailto:editor.i2m@iieta.org) <[editor.i2m@iieta.org](mailto:editor.i2m@iieta.org)>

Lampiran  
Kam, 18 Agu 09.34  
kepada saya

Terjemahkan pesan  
Nonaktifkan untuk: Inggris  
Dear author(s),

Thanks for patronizing Instrumentation Measure Métrologie (I2M) for publishing your research. The electronic version of your paper published in Volume 21, Number 3, 2022 is attached with this email. To read your paper online, please click:  
<https://www.iieta.org/journals/i2m/paper/10.18280/i2m.210305>

Manuskrip:



**Instrumentation Mesure Métrologie**

Vol., No., Month, Year, pp. \*\*-\*\*

---

## **A portable device based on an electrical conductivity sensor for the detection of monosodium glutamate (MSG) in soupy foods**

Anton Yudhana<sup>1\*</sup>, Retnosyari Septiyani<sup>2</sup>, Ilham Mufandi<sup>3</sup>, Phisca Aditya Rosyady<sup>1</sup>, Muhammad Fahri Husein<sup>1</sup>, Lutfi Ihza Mahendra Abdullatif<sup>1</sup>

<sup>1</sup> Department of Electrical Engineering, Faculty of Industrial Technology, Universitas Ahmad Dahlan, Unit IV, Jl. Ring-road

Selatan, Bantul 55191, Indonesia.

<sup>2</sup> Department of Food Service Business, Universitas Ahmad Dahlan, Jl. Pramuka, Sidikan, Umbulharjo, Yogyakarta, 55161, Indonesia.

<sup>3</sup> Department of Agro-Industrial Technology, University of Darussalam Gontor, Jl. Raya Siman, Ponorogo, East Java, 63471, Indonesia.

Corresponding Author Email: [eyudhana@ee.uad.ac.id](mailto:eyudhana@ee.uad.ac.id)

---

<https://doi.org/10.18280/ijssse.xxxxxx>

### **ABSTRACT**

**Received:**

**Accepted:**

---

**Keywords:**

*Electroconductivity Sensor; Food Monitoring ; Monosodium Glutamate (MSG); Soupy Food; Total Dissolved Solids (TDS)*

In everyday life, food is made with various taste images, including the savory taste obtained from monosodium glutamate (MSG). Although it is allowed as a food ingredient, excessive use of MSG and continuous consumption will have adverse effects on health. The effects of consuming MSG excessively on the body's organs include brain, ovarian, testicular, liver, kidney, heart, and respiratory disorders. MSG detection using technology is needed to control the consumption of MSG in the body. Hence, this study was focused on creating a portable device for detecting monosodium glutamate (MSG) in soupy foods: meatball soup and chicken soup. 3 mg of MSG was applied to each solution sample and four MSG brands, including SS, MW, AM, and MR. The concept of this prototype is based on the conductivity value and total dissolved solids (TDS) in the MSG solution. These solutions can produce an electrolyte because there is a sodium salt content in the MSG solution and water. The electrolyte solution can conduct electricity. An electrical conductivity sensor was installed in this prototype and these sensors included two electrode plates, a positive electrode (anode) and a negative electrode (cathode) with a distance of  $\pm 1$  cm. The conductivity sensor begins by starting a sensor into an electrolyte solution and, given an electric voltage input, changes to the value of the electric voltage. The sensor can be read and detect the MSG level in the solution. Then, the data are received and recorded in the DRF analog which is to process the signal from the sensor into analog form, and the data is sent to the Arduino Nano as a microcontroller. From the experiment result, the average conductivity value and TDS value of meatball soup are 21.98 mS and 7.91 Mg/I, while the average conductivity value and TDS value of Chicken Soto are 16.92 mS and 6.08 mg/I. This prototype was successfully created and implemented for the MSG detection in soupy foods.

---

# 1. Introduction

The five senses are one part of the human body that functions as a detector for human body conditions. One of them is tongue, which can detect the human body's condition through taste. The tongue is composed of nerves that can detect tastes (sweet, sour, bitter, salty, and umami) [1], [2]. The taste obtained by the tongue comes from either natural or chemical ingredients. Food is a source of energy in carrying out daily activities. In Indonesia, food is made with a varied taste image. In addition, food relies no longer only on sour and salty tastes, but also begins to contain a lot of umami that can enhance or suppress sweet, salty, sour, and bitter in solution [3], [4]. Umami is a savory taste obtained from the amino acid glutamate or monosodium glutamate (MSG) [5], [6].

Commercially, monosodium glutamate is one of the most familiar food additives used by the social public, which is available in every market or grocery store [1], [2]. In addition, monosodium glutamate is produced from a combination of several amino acids or purified with a small amount of hydrolyzed vegetable protein (HVP) [3]. Glutamic acid is classified as a non-essential amino acid because the human body can produce it independently [4]. According to the chemical formula, monosodium glutamate is divided into two, namely 2-aminopentanedioic and 2-amino glutamic acid. Consuming MSG in excess can cause toxic effects, CNS disorders, obesity, disturbances in adipose tissue physiology, liver damage, and reproductive dysfunction that was reported by [5]–[8]. Meanwhile, the amount of MSG consumption in the body needs to be controlled to maintain the health of the human body. Considering this, the need for a tool to measure the levels of MSG in food. On the other hand, the development of health technology has been widely developed to make it easier for the public

to monitor body health, such as research conducted by [9] to monitor the urine quality, heart rate monitoring [10], bone health monitoring [11], levels of creatinine [12]–[14], chronic kidney monitoring [15], [16].

There are many researchers from various disciplines who have conducted research in the field of testing MSG in food: [17] investigated the analysis technique using chromatography for the determination of L-glutamate in food samples, analysis technique using fluorescence by [18], capillary electrophoresis [19], spectrophotometry [20], chemiluminescence [21], surface plasmon resonance, etc. However, current research has widely used electrochemical sensor or electrochemical detection technology for testing MSG in food: [22] reported the monosodium glutamate detection (MSG) via an amperometric sensor immunosensor based on chitosan modified glassy carbon electrode. [23] experimented the fabricating a silicon biosensor microarray for the detection of glutamate. According review from [24] the oxidase and dehydrogenase enzymes are developed as two main categories for MSG detection in foods. The fabrication methods and performance of electrochemical glutamate are demonstrated in adsorption, covalent bonding, and cross-linking, and entrapment. Modification of electrodes using gold by voltammetry was found by [25] which this technique is to determine the L-glutamate behaviour based on the cyclic voltammetry. The development of electrochemical sensor based on nickel nanowire array and Pt coated nickel nanowire to detect glutamate reported by [26]. Applications Electrochemical sensors have been widely used in the industrial, environmental, and medical fields [27]. These concepts are visible for investigation or detection in real-time and in-situ [28].



The determination of the MSG dosage is done to reduce the use of MSG consumption, but this dosage rule is considered less than optimal [10]. The detection of MSG in foods, especially in soup, is not recommended by tasting it directly because it contains MSG which can damage organs and is toxic if consumed too much. Moreover, the technology required to detect and to measure the monosodium glutamate in soupy foods in real-time via sensor. The purposes of this study are to develop the portable device based on electrical conductivity sensor for determining the MSG in meatball soups and chicken soups.

The conductivity sensor is an electronic component that can measure the conductivity value of an electrolyte solution. The electrolyte solution can conduct electricity. The conductivity value in an electrolyte solution becomes a reference for the total solids concentration or Total Dissolved Solids (TDS). The higher the conductivity value, the greater the value of the solid concentration in the electrolyte solution. A conductivity sensor in the form of a probe at the end of which there are two electrode plates (positive electrode (anode) and a negative electrode (cathode) with a distance of  $\pm 1$  cm, the conductivity probe, if it is inserted into an electrolyte solution and given an electric voltage input changes to the value of the electric voltage. This happens because the ions in the water are separated into cations and anions, the cations are transferred to the negative electrode, and the anions will move to the positive electrode; the displacement of the ions causes the solution to become a conductor so that electricity can flow between the two electrodes. This paper created and analyzed a process tool for measuring MSG levels in a solution by using a conductivity sensor to measure the conductivity value of an electrolyte solution. The electrolyte solution can conduct electricity.

## 2. METHODS AND MATERIAL

### 2.1 System Overview

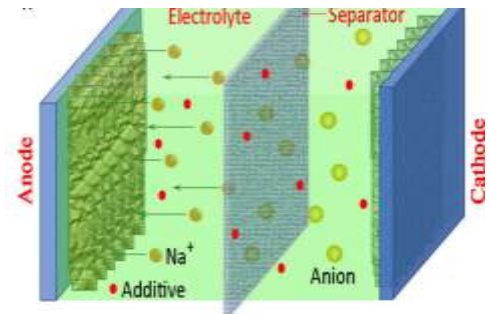

The proposed system in this study is to detect and measure the MSG content in soupy foods based on an electrical conductivity sensor because the conductivity sensor is an electronic device that can measure an electrolyte solution or a solution that has the ability to conduct electricity in MSG solutions in soupy foods. According to [29] monosodium glutamate (MSG) contains the sodium salt of glutamic acid and one of the most abundant nonessential amino acids found in nature. MSG can conduct electricity because MSG contains sodium salt in aqueous solution [30]. aqueous solutions and other seasonings are also conductive if they contain sodium salt. it can also affect the conductivity measurement. The MSG calculation carried out by [31] uses a comparison with voltage (Current) where the more MSG in food, the higher the current. In industry battery, sodium salt selected as basis of lithium salt via transpiring the cation. Sodium salt also is one of the important components in sodium-ion capacitors (SIC) electrolyte. Basic concepts in this study are conductivity sensor is able to read or identify the conductivity value in electrolyte solution. In addition, the conductivity value in water can be determined based on the total concentration

of solids or Total Dissolved Solid (TDS) in the soupy food. The higher the conductivity value, it can be said that the more the value of the concentration of solids in the electrolyte solution. The salt contained in MSG can conduct electricity from positive and negative ions. The displacement of the sodium salt solution from the anions and cations can be seen in the illustration in Figure 1.

**Figure 1.** The illustrate of electrolyte solution from Meng et al. [30]

Electrolyte solutions can be divided into two: strong electrolytes and weak electrolytes where MSG solution is a type of strong electrolyte solution because the MSG content is composed of sodium salt which decomposes completely in water into  $\text{Na}^+$  ions and  $\text{Cl}^-$  ions. Diagram The

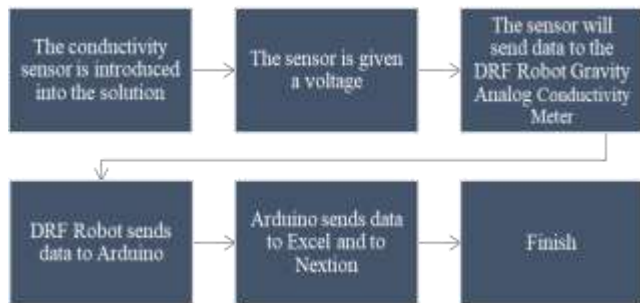

block diagram of a portable device for detecting and measuring MSG levels in soupy foods can be seen in Figure 2.

**Figure 2.** Diagram block for detecting MSG levels

Based on Figure 2. Portable tool for measuring and detecting MSG in soupy foods begins by inserting a conductivity sensor probe into a sample of soupy food/compound solution. Furthermore, the sensor probe is given a voltage which is used to determine the change in the voltage value on the two plates which are  $\pm 1$  cm apart in the probe, this change in value is recorded and detected as the conductivity value of the solution. The voltage and the conductivity value have a proportional relationship because voltage can be the baseline

to determine the MSG content in food/soup. The previous research from [32] has reported the experiment with the variation of the MSG and determining the MSG with the correlation between MSG and Voltage. The sensor sent from the conductivity sensor is received by the DRF analog conductivity meter where the analog DRF functions to process the signal from the sensor into analog form and the data is sent to the Arduino Nano. Arduino in this system functions as a microcontroller that processes data and sends data to the Nextion LCD and excel with the PLX method. Accuracy in this measurement is done by testing several times and comparing the prototype with standard measuring instruments. The PLX method is a parallelx microcontroller system for Microsoft excel. Each microcontroller is connected to the sensor and PC serial port to send data to excel. Data sent to excel is captured in real-time. We have added in the manuscript.

### 3. PROPOSED SYSTEM

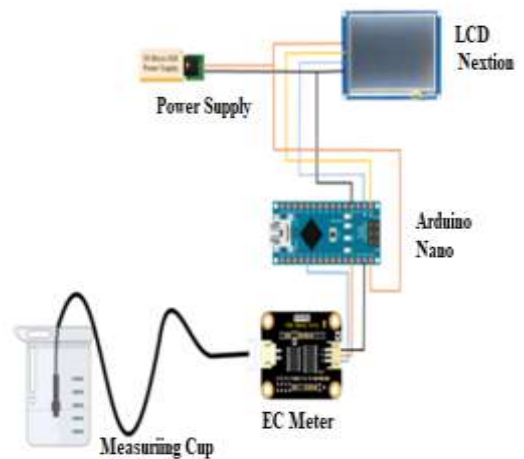

3a) Electrical wiring



3b) 3D design

**Figure 3.** Electrical circuit of proposed system, a) dan b)

As detail, the working principle of the conductivity sensor depends on the change of the ions in the water into cations and anions. Cations move to the negative electrode while anions move to the positive electrode. The transfer of ions causes the solution to become a conductor. Moreover, electricity can flow between the two electrodes. The conductivity sensor is equipped with two plates of positive electrode (anode) and negative electrode (cathode). Other components in the proposed system are supported by Arduino Nano as a microcontroller, DRF robot gravity analog conductivity meter, Nextion LCD, excel-PLX, and supply power (battery). The electrical circuit in the proposed system can be seen in Figure 3a and Figure 3b as a prototype layout.

Arduino is a platform used in computer programming as a small, complete, and breadboard microcontroller. In addition, Arduino Nano is equipped with an operating voltage of 5 volts, 32 Kb flash memory, and a clock speed of 16 MHz. The system used to measure the electrical conductivity of a soupy food solution is DFR robot gravity. This product operates with Arduino and the DRF library. Nextion LCD is used as a display of MSG measurement results in soupy foods. Nextion LCD can display a lot of data and interface very

well. The data obtained from the field in real-time is recorded and stored in excel form. On the MSG portable device using the PLX-DAQ with the advantage of being able to provide easy spreadsheets of data collected in the field, laboratory sensor analysis, and equipment monitoring. According to Figure 2, the instructions for the system to run the MSG measurement and detection program can be seen in Figure 4.

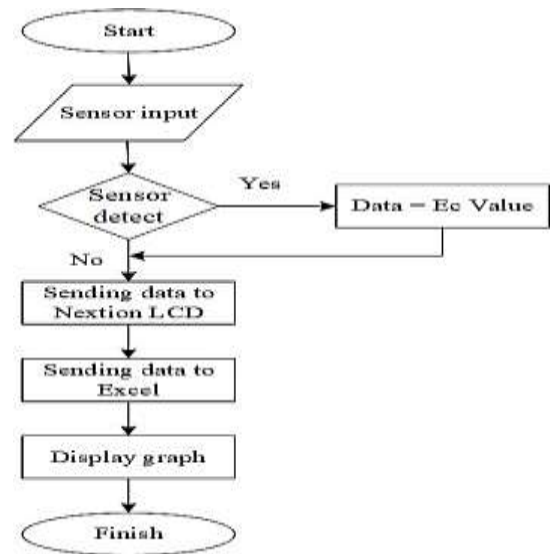

**Figure 4.** System flow chart on computer program instructions.

### 3.1 MSG Calculation

Based on the provisions of the WHO's Joint Expert Committee on Food Additives (JECFA), it is stated that the MSG threshold is only around 100 milligrams per kilogram of body weight.

$$Usage\ Limit = \frac{100\ mg\ MSG}{Weight\ (kg)} \quad (1)$$

From the above provisions, it means that if a person has a bodyweight of 60 kilograms, then the person has a

limit of using MSG of 6 grams per day (100 mg / 60 Kg = 0.006 Kg or 6 grams). Meanwhile, the calculation of the conductivity sensor is determined based on the total dissolved solids (TDS) of a liquid. Conductivity is a measure of the ability of water or solution through electricity. This ability is directly related to the concentration of ions in the water. Ion Conductivity comes from dissolved salts and inorganic materials. The relationship between the conductivity value of a solution and the solid value is to measure the TDS level in the soupy food. The conductivity value at an electrolyte solution as a reference for the total concentration of solids or total Dissolved Solids (TDS). the conductivity value of the solution obtained by calculation from the solution solids value by calculating the conductivity value with the correlation value for water as follows:

$$TDS = Ke \times EC \quad (2)$$

Where, *TDS* represents Total dissolved solids (Mg/L). *Ke* is Correlation Factor or a constant of proportionality. *EC* is Conductivity Value. The relation between TDS and EC is a function of the type and nature of the cation and anions in the water. In addition, the detailed relationship between *Ke* and *EC* was published in 1989 which the author was reported that the correlation based on its salinity [33]. The ionic composition of the water affects the TDS-EC relationship. *Ke* value in water from 0.55 to 0.85 [34]–[36]. TDS is an indicator of the number of particles or substances, either in the form of organic or non-organic compounds. The correlation between electrical conductivity (*EC*) and total dissolved solids (TDS) are proportional. [37] was proved the correlation between EC and TDS in groundwater hypothetical salts and sea water [38]. The conductivity value at an electrolyte solution as a reference for the total concentration of solids or total Dissolved Solids (TDS). The higher the conductivity value, it can be said increase the value of the concentration of solids in the electrolyte solution. The principle of calculating total dissolved solids (TDS) can determine the dissolved compound in a liquid. in addition, the conductivity sensor becomes a

component that can measure dissolved compounds in a liquid which the conductivity of the solution is influenced by the electrolyte value given the electric voltage so that changes occur. The changes in the value of the electric voltage was happened because the ions in the water was separated into cations and anions. the cations are move to the negative electrode and the anions will move to the positive electrode, the movement of ions causes the solution to become a conductor. Moreover, electricity can flow between the two electrodes.

### 3.2 Experimental Procedures

Firstly, the testing of a portable tools to measure and detect MSG was applied to meatball soup with 5 samples of meatballs from different places. The meatball samples were selected with dose of MSG. In this study, the sizes of the meatballs were not the same. This is because the samples of meatballs are taken from small-scale business sellers who do not have standardized sizes in their manufacture. In Indonesia, small meatball traders do not use standardized tools in terms of production.

The portable tool of MSG has read the average conductivity value of each sample. After that, this portable device was applied to samples with different soups, such as: chicken noodle, soto meat, chicken soto, vegetable soup, and chicken soup. All test results have been displayed on the LCD in graphical form.

## 4. RESULTS AND DISCUSSION

### 4.1. Conductivity Testing on MSG from The Different Brands

This test aims to determine the conductivity values produced from different types of MSG such as: SS, MW, AM, and MR. This type of MSG is an original brand from Indonesia. The results of this test were indicated that the monosodium glutamate solution can produce an

electrolyte solution from a solution of water and a mixture of 3 mg MSG. In this study, MSG was mixed with different productions and the volume was added in multiples of 3 mg while the mixing water volume remained

Electrolyte solution is used to calculate the conductivity value. The test is carried out at a temperature of 50-40°C within 15 seconds. The monosodium glutamate brand is indicated using a color where the MR is Tosca, MW is red, SS is blue, and AM is green. The determination of conductivity value was tested in real-time and it can be seen on the LCD monitor. From the test results, it was found that each MSG has a different conductivity value that can be seen in Figure 5. The highest conductivity value is obtained from MR and the lowest is AM. each brand of MSG has an influence on the level of conductivity and TDS values in soupy foods. This result is relevant with the research in the field of conductivity sensor to determine the taste sensing system [39]–[41]. The conductivity value changes in solution by change in concentration. Electrical conductivity in each sample will be different based on the electrolyte in solution. In addition,

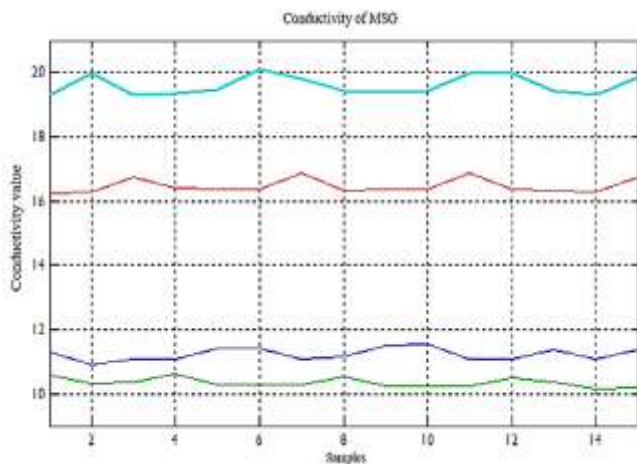

electrical conductivity also can be applied in the field of agriculture to determine the water quality [42], [43].

**Figure 5.** The conductivity value from the different type of monosodium glutamate.

#### 4.2. The Detection of MSG in Soupy Foods (Meatball Soups)

This experiment was conducted to measure and detect of Monosodium Glutamate (MSG) on meatballs soup by using an electrical conductivity

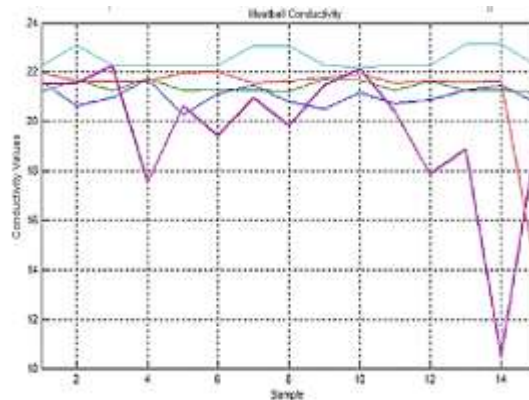

sensor. sample meatballs soup using the same sample size and the same dosage. In addition, the test was carried out in real-time which can be seen in Figure 6. The average of conductivity in meatball soup was determined. Five samples of meatball soup are carried out for MSG testing.

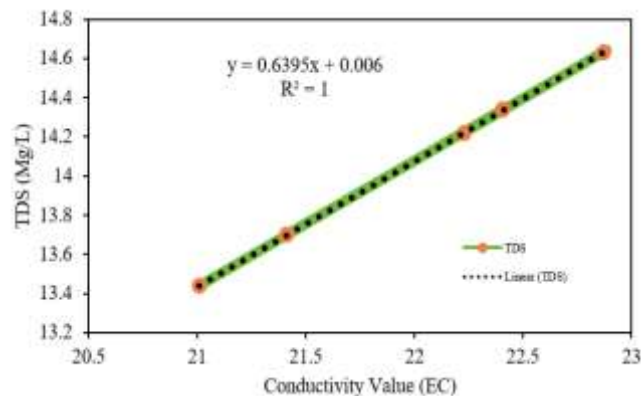

**Figure 6.** Conductivity graph of meatball samples

According to Figure 6, the testing result indicated that the average of conductivity from five samples of meatball soup from different places are 21 mS (Micro-Siemens). The five meatballs were tested at a temperature of around 20-27°C with the same size of 750 mm. Meatball A is blue, Meatball B is green, Meatball C is red, Meatball D is Tosca, and Meatball E is Purple.



The five meatball samples have an average sample conductivity as shown in Table 1.

**Table 1.** Average of conductivity value of meatballs soup

Meatballs soups				
Sample A	Sample B	Sample C	Sample D	Sample E
21.01	22.41	22.23	22.87	21.41

The calculation of MSG content in meatball samples can be done by calculating the solute value using the TDS method. The average EC value of each sample is multiplied by the correlation factor value ( $Ke$ ) of 0.64 [37]. According to equation 2,  $Ke$  determine from references [34]–[36] which  $Ke$  value for nature water is from 0.55-0.85. the portable device on this system was applied to read the conductivity value (EC) from meatball soup and chicken soup then EC is multiplied with 0.64. The TDS value of each meatball sample is obtained as in Table 2. The conductivity and TDS value of the meatballs soup were 21.98 mS and 14.02 Mg/l, respectively.

**Table 2.** The conductivity value and TDS value of meatballs soup

Sample	Conductivity Value (EC) ( $\mu$ S)	Corelation Factor ( $Ke$ )	TDS Value (Mg/l)
A	21.01	0.64	13.44
B	22.41		14.34
C	22.23		14.22
D	22.87		14.63
E	21.41		13.70
<b>average</b>	<b>21.98</b>		<b>14.02</b>

Based on Table 2, the corealtion between conductivity value and TDS from meatball soup obtained  $R^2$  of 1. It can be seen in Figure 7.

**Figure 7.** The correlation between EC and TDS

#### 4.3 The detection of MSG in soupy food (Chicken Soto)

Soupy food in this study appllied in chicken soup. The test was carried out with the same size and dose and was carried out on 5 samples of soto from different places. real-time testing can be seen in Figure 8.

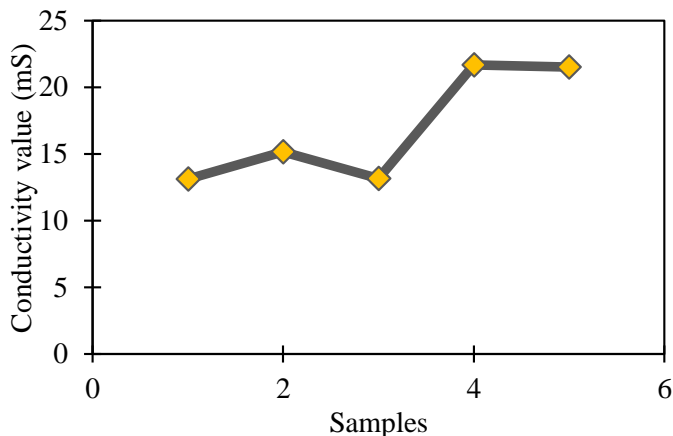

**Figure 8.** Average of conductivity value of chicken food

Based on the Figure 8, the average conductivity value of the chicken soup from five different samples and different brands of MSG as well as the addition of kitchen spices such as salt and flavouring. Sample 1 (Soto 1) uses MSG with the AM brand added with table salt has the lowest value compared to the other four soups. Sample 4 (Soto 4) was tested using MR brand MSG added with salt, with the test results that Soto 4 had the highest conductivity value. The SS brand used by traders of sample 3 (Soto 3) and sample 2 (Soto 2) has almost the same value around the value of 13-15.6  $\mu$ S. Sample 5 (Soto 5) used AM branded MSG and salt. This result is also influenced by the addition of table salt which greatly affects the conductivity value of a solution, because table salt contains 39% sodium which is a strong electrolyte which has a higher level of electrolyte content compared to MSG which only contains 12% sodium in it. The average conductivity value and the average TDS value from the MSG test on Chicken Soto can be seen in table 3. From the five tests, the average conductivity value was 16.92 mS and the TDS value for Chicken Soto was 10.82 mg/l.

**Table 3.** Average of conductivity value and TDS value on the Chicken Soto.

Sample (Chicken Soto)	Conductivity Value (EC) ( $\mu\text{S}$ )	Corelation Factor (Ke)	TDS Value (Mg/L)
1	13.12	0.64	8.39
2	15.16		9.70
3	13.16		8.42
4	21.67		13.86
5	21.51		13.76
<b>Average</b>	<b>16.92</b>		<b>10.82</b>

Based on Tabel 3, the corealtion between conductivity value and TDS from chicken soup obtained  $R^2$  of 1. It can be seen in Figure 9.

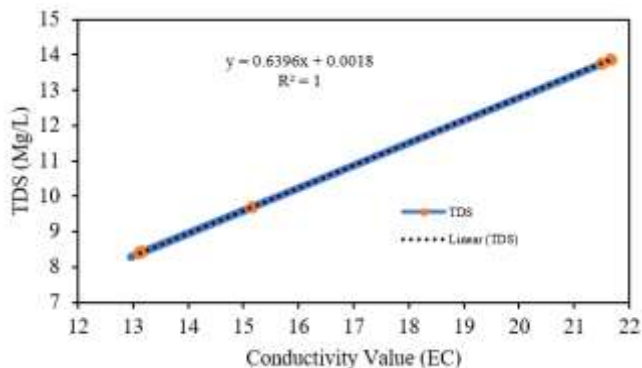

**Figure 9.** The correlation between EC and TDS

## 5. CONCLUSION

Excessive consumption of MSG can affect body health such as liver, kidney, respiratory disorders, ovarian and brain disorders. This study is to create a portable device for testing and measuring MSG in soupy foods. The detection of MSG levels has been successfully implemented in meatball soup and chicken soup by using the principle of TDS (Total Dissolved Solid). The MSG detection tool is made in real-time via Excel PLX and Nextion LCD to display the MSG value in the soup. Meatball soup

and chicken soup contains MSG greatly affect the conductivity value if salt is added. Experiments of 5 meatball soup and Chicken Soto from different places and the adding the different of type MSG and kitchen salt obtained data results that show the average of conductivity value and TDS value of meatball soup is 21.98 mS and 14.02 Mg/l, while the average of conductivity value and TDS value of Chicken Soto is 16.92 mS and 10.82 Mmg/l.

## acknowledgment

We would like to show our gratitude to Institute of Research and Community Services Universitas Ahmad Dahlan for support the research.

## REFERENCES

- [1] Al-Agili, Z.H. (2020). The effect of food additives (monosodium glutamate - MSG) on human health - a critical review. J. AlMaarif Univ. Coll., 362-369. <https://doi.org/10.51345/v31i1.235.g162>
- [2] Kazmi, Z., Fatima, I., Perveen, S., Malik, S.S. (2017). Monosodium glutamate: Review on clinical reports. Int. J. Food Prop., 20(2): 1807-1815. <https://doi.org/10.1080/10942912.2017.1295260>
- [3] Jeon, S.Y., Lee, Y.M., Kim, S.S., Kim, K.O. (2020). Effect of added hydrolyzed vegetable proteins on consumers' response for Doenjang (Korean traditional fermented soybean paste) soup. Food Sci. Biotechnol., 29(1): 45-53. <https://doi.org/10.1007/s10068-019-00646-0>
- [4] Kumar, R., Vikramachakravarthi, D., Pal, P. (2014). Production and purification of glutamic acid: A critical review towards

- process intensification. *Chem. Eng. Process. Process Intensif.*, 81: 59-71. <https://doi.org/10.1016/j.cep.2014.04.012>
- [5] Niaz, K., Zaplatic, E., Spoor, J. (2018). Extensive use of monosodium glutamate: A threat to public health? *EXCLI J.*, 17: 273-278. <https://doi.org/10.17179/excli2018-1092>
- [6] Jinap, S., Hajeb, P. (2019). Glutamate. Its applications in food and contribution to health. *Appetite*, 55(1): 1-10. <https://doi.org/10.1016/j.appet.2010.05.002>
- [7] Zangfirescu, A., Ungurianu, A., Tsatsakis, A.M., Nițulescu, G.M., Kouretas, D., Veskoukis, A., Tsoukalas, D., Engin, A.B., Aschner, M., Margină, D. (2019). A review of the alleged health hazards of monosodium glutamate. *Compr. Rev. Food Sci. Food Saf.*, 18(4): 1111-1134. <https://doi.org/10.1111/1541-4337.12448>
- [8] Bera, T.K., Kar, S.K., Yadav, P.K., Mukherjee, P., Yadav, S. (2017). Effects of monosodium glutamate on human health : A systematic review Figure 1: Chemical structure of Monosodium Glutamate. *World J. Pharm. Sci.*, 5(4): 139-144.
- [9] Yudhana, A., Mukhopadhyay, S., Prima, O.D.A., Akbar, S.A., Nuraisyah, F., Mufandi, I., Fauzi, K.H., Nasyah, N.A. (2021). Multi sensor application-based for measuring the quality of human urine on first-void urine. *Sens. Bio-Sensing Res.*, 34: 100461. <https://doi.org/10.1016/J.SBSR.2021.100461>
- [10] Al Irfan, S., Yudhana, A., Mukhopadhyay, S.C., Karas, I.R., Wati, D.E., Puspitasari, I. (2019). Wireless communication system for monitoring heart rate in the detection and intervention of emotional regulation. *Proc. - 1st Int. Conf. Informatics, Multimedia, Cyber Inf. Syst. ICIMCIS 2019*, pp. 243-248. <https://doi.org/10.1109/ICIMCIS48181.2019.8985210>
- [11] Afsarimanesh, N., Mukhopadhyay, S.C., Kruger, M., Yu, P. (2017). Sensing system for bone health monitoring. *Smart Sensors, Meas. Instrum.*, 22: 23-44. [https://doi.org/10.1007/978-3-319-47319-2\\_2](https://doi.org/10.1007/978-3-319-47319-2_2)
- [12] Prabhu, S.N., Mukhopadhyay, S.C., Gooneratne, C., Davidson, A.S., Liu, G. (2019). Interdigital sensing system for detection of levels of creatinine from the samples. *Proc. Int. Conf. Sens. Technol. ICST*, pp. 2-7. <https://doi.org/10.1109/ICST46873.2019.9047672>
- [13] Arif Topçu, A., Özgür, E., Yılmaz, F., Bereli, N., Denizli, A. (2019). Real time monitoring and label free creatinine detection with artificial receptors. *Mater. Sci. Eng. B Solid-State Mater. Adv. Technol.*, 244: 6-11. <https://doi.org/10.1016/j.mseb.2019.04.018>
- [14] Rakesh Kumar, R.K., Shaikh, M.O., Chuang, C.H. (2021). A review of recent advances in non-enzymatic electrochemical creatinine biosensing. *Anal. Chim. Acta*, 1183: 338748. <https://doi.org/10.1016/j.aca.2021.338748>
- [15] Promphet, N., Hinestroza, J.P., Rattanawaleedirojn, P., Soatthiyanon, N., Siralertmukul, K., Potiyaraj, P., Rodthongkum, N. (2020). Cotton thread-based wearable sensor for non-invasive simultaneous diagnosis of diabetes and kidney failure. *Sensors Actuators, B Chem.*, 321: 128549. <https://doi.org/10.1016/j.snb.2020.128549>
- [16] Desai, D., Kumar, A., Bose, D., Datta, M. (2018). Ultrasensitive sensor for detection of early stage chronic kidney disease in human. *Biosens. Bioelectron.*, 105: 90- 94. <https://doi.org/10.1016/j.bios.2018.01.031>
- [17] Monošík, R., Středanský, M., Šturdík, E. (2013). A biosensor utilizing l -glutamate



- dehydrogenase and diaphorase immobilized on nanocomposite electrode for determination of l- glutamate in food samples. *Food Anal. Methods*, 6: 521-527. <https://doi.org/10.1007/s12161-012-9468-5>
- [18] Soyseven, M., Arli, G. (2021). Method validation and rapid determination of monosodium glutamate in various food products by HPLC–fluorescence detection and method optimization of HPLC–evaporative light scattering detection approach without derivatization. *Journal of Chromatographic Science*. <https://doi.org/10.1093/chromsci/bmab122>
- [19] Aung, H.P., Pyell, U. (2016). In-capillary derivatization with o-phthalaldehyde in the presence of 3- mercaptopropionic acid for the simultaneous determination of monosodium glutamate, benzoic acid, and sorbic acid in food samples via capillary electrophoresis with ultraviolet detectio. *J. Chromatogr. A*, 1449: 156-165. <https://doi.org/10.1016/j.chroma.2016.04.033>
- [20] Ali, H.M., Hammad, S.F., El-Malla, S.F. (2020). Green spectrophotometric methods for determination of a monosodium glutamate in different matrices. *Microchem. J.*, 169: 106622. <https://doi.org/10.1016/j.microc.2021.106622>
- [21] Costin, J.W., Francis, P.S., Lewis, S.W. (2003). Selective determination of amino acids using flow injection analysis coupled with chemiluminescence detection. *Anal. Chim. Acta*, 480(1): 67-77. [https://doi.org/10.1016/S0003-2670\(02\)01645-8](https://doi.org/10.1016/S0003-2670(02)01645-8)
- [22] Devi, R., Gogoi, S., Barua, S., Sankar, H. (2019). Electrochemical detection of monosodium glutamate in foodstu ff s based on Au @ MoS 2/chitosan modi fi ed glassy carbon electrode. *Food Chem.*, 276: 350-357. <https://doi.org/10.1016/j.foodchem.2018.10.024>
- [23] Moldovan, N., Blaga, I.I., Billa, S., Hossain, I., Gong, C.G., Jones, C.E., Murray, T.A., Divan, R., Siddiqui, S., Arumugam, P.U. (2021). Chemical Brain-implantable multifunctional probe for simultaneous detection of glutamate and GABA neurotransmitters. *Sensors Actuators B. Chem.*, 337: 129795. <https://doi.org/10.1016/j.snb.2021.129795>
- [24] Hughes, G., Pemberton, R.M., Fielden, P.R., Hart, J.P. (2016). The design, development and application of electrochemical glutamate biosensors. *Trends Anal. Chem.*, 79: 106-113. <https://doi.org/10.1016/j.trac.2015.10.020>
- [25] Dorozhko, E.V, Korotkova, E.I., Shabaeva, A.A., Mosolkov, A.Y. (2015). Electrochemical determination of l-glutamate on a carbon-containing electrode modified with gold by voltammetry. *Procedia Chem.*, 15(3822): 365-370. <https://doi.org/10.1016/j.proche.2015.10.058>
- [26] Jamal, M., Hasan, M., Mathewson, A., Razeeb, K.M. (2013). Biosensors and bioelectronics disposable sensor based on enzyme-free Ni nanowire array electrode to detect glutamate. *Biosens. Bioelectron.*, 40(1): 213-218. <https://doi.org/10.1016/j.bios.2012.07.024>
- [27] Bakker, E., Qin, Y. (2010). Electrochemical sensors: A review. *Anal Chem.*, 78(12): 3965-3984. <https://doi.org/10.1021/ac060637m.Electrochemical>
- [28] Monzó, J., Insua, I., Fernandez-Trillo, F., Rodriguez, P. (2015). Fundamentals, achievements and challenges in the electrochemical sensing of pathogens.

- Analyst, 12: 1- 37.  
<https://doi.org/10.1039/C5AN01330E>
- [29] A. Campbell, "Monosodium Glutamate (MSG)," *Encycl. Toxicol.*, vol. 3, pp. 391–392, 2014, <https://doi.org/10.1016/B978-0-12-386454-3.00040-3>
- [30] Meng, F., Long, T., Xu, B., Zhao, Y., Hu, Z., Zhang, L. (2020). Electrolyte technologies for high performance sodium-ion capacitors. *Front. Chem.*, 8: 1-6. <https://doi.org/10.3389/fchem.2020.00652>
- [31] B. Batra, M. Yadav, and C. S. Pundir, "I - Glutamate biosensor based on I -glutamate oxidase immobilized onto ZnO nanorods / polypyrrole modified pencil graphite electrode," vol. 105, pp. 428–436, 2016. <http://dx.doi.org/10.1016/j.bej.2015.10.012>
- [32] Liu, J., Fan, Y., Chen, G., Liu, Y. (2021). Highly sensitive glutamate biosensor based on platinum nanoparticles decorated MXene-Ti<sub>3</sub>C<sub>2</sub>T<sub>x</sub> for L - glutamate determination in foodstuffs. *LWT*, 148: 111748. <https://doi.org/10.1016/j.lwt.2021.111748>
- [33] Walton, N.R.G. (1989). Electrical conductivity and total dissolved solids-what is their precise relationship? *Desalination*, 12(72): 275-292. [https://doi.org/10.1016/0011-9164\(89\)80012-8](https://doi.org/10.1016/0011-9164(89)80012-8)
- [34] Atekwana, E.A., Atekwana, E.A., Rowe, R.S., Werkema, D.D., Legall, F.D. (2004). The relationship of total dissolved solids measurements to bulk electrical conductivity in an aquifer contaminated with hydrocarbon. *J. Appl. Geophys.*, 56: 281-294. <https://doi.org/10.1016/j.jappgeo.2004.08.003>
- [35] Taylor, M., Elliott, H.A., Navitsky, L.O., Navitsky, L.O. (2018). Relationship between total dissolved solids and electrical conductivity in Marcellus hydraulic fracturing fluids. *Water Sci. Technol.*, 77(8): 1998-2004. <https://doi.org/10.2166/wst.2018.092>
- [36] Thirumalini, S., Joseph, K. (2009). Correlation between electrical conductivity and total dissolved solids in natural waters. *Malaysian J. Sci.*, 28(1): 55-61. <https://doi.org/10.22452/mjs.vol28no1.7>
- [37] Al Dahaan, S.A.M., Al-Ansari, N., Knutsson, S. (2016). Influence of groundwater hypothetical salts on electrical conductivity total dissolved solids. *Sci. Res. Publ.*, 8(11): 823-830. <https://doi.org/10.4236/eng.2016.811074>
- [38] Sylus, K.J., Ramesh, H. (2015). The study of sea water intrusion in coastal aquifer by electrical conductivity and total dissolved solid method in gurgur and netravathi river basin. *Aquat. Procedia*, 4: 57-64. <https://doi.org/10.1016/j.aqpro.2015.02.009>
- [39] Nag, A., Mukhopadhyay, S.C. (2018). Fabrication and implementation of printed sensors for taste sensing applications. *Sensors Actuators, A Phys.*, 269: 53-61. <https://doi.org/10.1016/j.sna.2017.11.023>
- [40] Sehra, G., Cole, M., Gardner, J.W. (2004). Miniature taste sensing system based on dual SH-SAW sensor device: An electronic tongue. *Sensors Actuators, B Chem.*, 103(1-2): 233-239. <https://doi.org/10.1016/j.snb.2004.04.055>
- [41] Leonte, I.I., Sehra, G., Cole, M., Hesketh, P., Gardner, J.W. (2006). Taste sensors utilizing high-frequency SHSAW devices. *Sensors Actuators, B Chem.*, 118(1-2): 349-355. <https://doi.org/10.1016/j.snb.2006.04.040>
- [42] Fenta, M.C., Anteneh, Z.L., Szanyi, J., Walker, D. (2020). Hydrochemical data on groundwater quality for drinking and irrigation use around Dangila town, Northwest Ethiopia. *Data Br.*, 31: 105877. <https://doi.org/10.1016/j.dib.2020.105877>

- [43] Lakshmikantha, V., Hiriyanagowda, A., Manjunath, A., Patted, A., Basavaiah, J., Anthony, A.A. (2021). IoT based smart water quality monitoring system. Glob. Transitions Proc., 2(2): 181-186.

<https://doi.org/10.1016/j.gltp.2021.08.06>