



UNIVERSITY OF LEEDS

This is a repository copy of *An Elastomeric Energy Storage System to Improve Vehicle Efficiency.*

White Rose Research Online URL for this paper:
<http://eprints.whiterose.ac.uk/2108/>

Monograph:

Kirby, H.R., Clegg, S.J., Crolla, D.A. et al. (2 more authors) (1997) An Elastomeric Energy Storage System to Improve Vehicle Efficiency. Working Paper. Institute of Transport Studies, University of Leeds , Leeds, UK.

Working Paper 491

Reuse

See Attached

Takedown

If you consider content in White Rose Research Online to be in breach of UK law, please notify us by emailing eprints@whiterose.ac.uk including the URL of the record and the reason for the withdrawal request.



eprints@whiterose.ac.uk
<https://eprints.whiterose.ac.uk/>



White Rose Research Online

<http://eprints.whiterose.ac.uk/>

ITS

[Institute of Transport Studies](#)

University of Leeds

This is an ITS Working Paper produced and published by the University of Leeds. ITS Working Papers are intended to provide information and encourage discussion on a topic in advance of formal publication. They represent only the views of the authors, and do not necessarily reflect the views or approval of the sponsors.

White Rose Repository URL for this paper:
<http://eprints.whiterose.ac.uk/2108>

Published paper

H.R. Kirby, S.J. Clegg, D.A. Crolla, R.A. Duckett, M.S. Dougherty (1997) *An Elastomeric Energy Storage System to Improve Vehicle Efficiency*. Institute of Transport Studies, University of Leeds, Working Paper 491

Working Paper 491

April 1997

AN ELASTOMERIC ENERGY STORAGE SYSTEM TO IMPROVE VEHICLE EFFICIENCY

Final Report to EPSRC (Grant Number GR/K78430)

H.R. Kirby, S.J. Clegg (*ITS*), **D.A. Crolla** (*Mechanical Engineering*),
R.A. Duckett (*IRC in Polymer Science and Technology*) and
M.S. Dougherty (*CTS, Dalarna University, Sweden*)

ITS Working Papers are intended to provide information and encourage discussion on a topic in advance of formal publication. They represent only the views of the authors, and do not necessarily reflect the views or approval of the sponsors.

This work was sponsored by the Engineering and Physical Sciences Research Council

UNIVERSITY OF LEEDS
Institute for Transport Studies

ITS Working Paper 491

April 1997

**AN ELASTOMERIC ENERGY STORAGE
SYSTEM TO IMPROVE VEHICLE
EFFICIENCY**

Final Report to EPSRC (Grant Number GR/K78430)

Project information

Project title: An elastomeric energy storage system to improve vehicle efficiency
Sponsored by: The Engineering and Physical Sciences Research Council
Grant reference: GR/K78430
Leeds reference: a/c 446560

Document control information

Title: Final Report to EPSRC
Authors: H.R. Kirby, S.J. Clegg (*ITS*), D.A. Crolla (*Mechanical Engineering*);
R.A. Duckett (*IRC in Polymer Science and Technology*),
M.S. Dougherty (*CTS, Darlana University, Sweden*)
Reference number:
Version number : 1.0
Date :29 April 1997
Distribution : ITS staff, Mark Dougherty, David Crolla, Alan Duckett
Availability : ITS staff, Mark Dougherty, David Crolla, Alan Duckett
File : k:\common\lisa\miscell\epsrcfin.doc
Authorised by : F.O. Montgomery
Signature : 

© Institute for Transport Studies, University of Leeds, UK

CONTENTS

Summary

1.	Background	1
2.	Objectives	1
3.	Management and Collaboration	1
4.	Research strategy	2
5.	Scientific and Technical Achievements	2
	5.1 The choice of elastomer	2
	5.2 Design concepts	3
	5.3 System overview	3
	5.4 Vehicle performance characteristics	4
	5.5 Reduced engine size	5
	5.6 Driving cycle studies	5
	5.7 Fuel consumption	6
	5.8 Emissions	6
6.	Related work	6
7.	Dissemination	6
8.	Conclusions and recommendations	7
	8.1 Significance in relation to current engineering practice	7
9.	Publications and conference papers	8
10.	Other references	8

AN ELASTOMERIC ENERGY STORAGE SYSTEM TO IMPROVE VEHICLE EFFICIENCY

Final Report to EPSRC on Grant Number GR/K78430

SUMMARY

Most regenerative braking systems studied hitherto have made use of batteries, flywheels and hydraulic accumulators. The present study has investigated the use of elastomers for such systems. The ability of elastomers to store large amounts of energy, together with the fact that this energy can be recovered quickly, makes them attractive materials for propulsion devices and inherently simple to engineer.

Theoretical and experimental research has shown that the development of an elastomeric regenerative braking system does appear to be technically feasible. The predicted rubber characteristics have been compared with the known characteristics of a conventional engine. The results show that the tractive effort produced by the elastomer is capable of matching the characteristics of the engine considered in this work. Rates of input and output energy have also been calculated to determine the process of energy storage and retrieval throughout a typical driving cycle. The energy store appears to be capable of reproducing many stages of the three driving cycles considered.

When there is insufficient energy in the system, power boosts from the conventional engine are required. In order to increase the overall savings achieved by the system, the engine was 'replaced' by one which had force (and therefore power) characteristics of one half of the conventional engine initially considered. It was found that the reduced power engine was sufficient to supply the extra power boosts as required.

In addition to reduced engine and brake wear, fuel consumption and emissions have been shown to be drastically reduced. If these values could be achieved in practice, the benefits of such a system are immediately apparent. The potential financial savings available to the car user corresponding to the decrease in fuel consumption would provide a strong incentive. Environmentally the benefits are two fold, firstly the reduction in pollution emissions means cleaner air and has an impact on global warming, and secondly reduced fuel consumption means that fossil fuel reserves may last considerably longer than currently predicted thus reducing the immediate need for alternatives sources.

Keywords: regenerative braking systems, elastomer, energy, driving cycles, fuel consumption, pollution emissions.

Contacts:

HR Kirby (Institute for Transport Studies; fax: 0113 233 5334)

tel: 0113 233 5330; email: h.r.kirby@its.leeds.ac.uk

Dr RA Duckett (IRC in Polymer Science and Technology; fax: 0113 233 3846)

tel: 0113 233 3816; email: r.a.duckett@leeds.ac.uk

Professor DA Crolla (Department of Mechanical Engineering; fax: 0113 242 4611)

tel: 0113 233 2139; email: d.a.crolla@leeds.ac.uk

Dr SJ Clegg (Institute for Transport Studies; fax: 0113 233 5334)

tel: 0113 233 6608; email: s.j.clegg@its.leeds.ac.uk

Address: The University of Leeds, Leeds LS2 9JT

AN ELASTOMERIC ENERGY STORAGE SYSTEM TO IMPROVE VEHICLE EFFICIENCY

Final report to EPSRC on Grant Number GR/K78430

1. BACKGROUND

When the brakes are applied in a vehicle, kinetic energy is converted to heat as friction between the brake pads and wheels and the energy is wasted. Regenerative braking refers to a process in which a portion of the kinetic energy of the vehicle is stored by a short term storage system. Energy normally dissipated is directed by a power transmission system to the energy store during deceleration. That energy is held until required again by the vehicle, whereby it is converted back into kinetic energy and used to accelerate the vehicle.

Regenerative braking results in a reduction in the amount of work done by the engine, in turn reducing the amount of prime energy required to propel the vehicle. The end result is improved fuel economy and a corresponding reduction in emissions, together with reduced engine and brake wear. The energy storage unit must be compact, durable and capable of handling high power levels efficiently. The key issues are that the increased fuel efficiency and reduction in emissions over a specified lifetime should outweigh cost and weight penalties, the system should not be too complex and should be safe.

The idea of regenerative braking has been widely exploited in electrified railways by using the motors of trains as generators whilst braking. For vehicles powered by an internal combustion engine (ICE) it is much harder to implement a regenerative braking system (RBS) because unlike an electric motor the energy conversion processes involved in an ICE are irreversible. Additional equipment is needed to both convert and store the energy. Elastomeric energy storage is promising because of its inherent simplicity. In theory the axle or driveline is connected to an elastomer system so that vehicle motion stresses the elastomer.

2. OBJECTIVES

The overall aim of this investigation is to explore the concepts of elastomeric energy storage and retrieval in the design of an elastomeric regenerative braking system. Specific objectives were:

- to identify the most suitable choice of elastomer for use in an energy storage system
- to investigate how such an energy storage system might be integrated into a vehicle as a regenerative braking system.
- assess the benefits of such a system
- education of school children via their participation in the research.

3. MANAGEMENT AND COLLABORATION

The role of Principal Investigator was taken over by Howard Kirby from the Institute for Transport Studies when Mark Dougherty departed to Sweden. Advice on the choice and testing of materials was provided by Dr R. A. Duckett from the Inter-Disciplinary Research Centre in Polymer Science and Technology in the Department of Physics. The Instron Tensile Testing equipment was used to study the properties of various rubber types under tension. Advice and guidance relating to vehicle dynamics was provided by Professor D.A.Crolla from the Department of Mechanical Engineering, Professor of Automotive Engineering.

In order to show schoolchildren that science and technology can solve problems including pollution and waste, and to access a source of lateral thinking, a group of Year 11 pupils from Benton Park School, Rawdon were involved in the small scale prototyping stages. The head of science, Mr Casey, arranged for suitable timing of the sessions and ensured that the work content was suitable.

4. RESEARCH STRATEGY

A literature survey (Clegg, 1996a) yielded information on the main types of regenerative braking systems (RBS) to date. These include the motor/generator used in battery powered electric vehicles, the pump/motor used in hydraulic accumulator systems and flywheel systems. For various reasons, mainly concerning complexity, expense and safety issues, none of these systems have been generally accepted. The concept of elastomeric systems is not a new one. Some research on elastomeric RBS was published by the Eaton Corporation in 1982 [1], and researchers at the Malaysian Rubber Producers Research Association (MRPRA) also considered the idea in the 1960's although nothing was published.

Due to the timing of the project coinciding with GCSE preparation and examinations, materials testing was carried out simultaneously with the project at Benton Park School. The concepts were explained and demonstrated by a series of experiments. Designs for three proposed systems were drawn and models built from Meccano. Assessment of the feasibility of the entire system highlighted various points which would require detailed consideration before a realistic design could be produced (Clegg, 1996b). At Professor Crolla's suggestion more emphasis was placed on calculations to determine vehicle performance and the capability of an elastomeric system to achieve this required performance. Specific driving cycles were used to assess the capability of the RBS. A detailed report on the performance evaluation was prepared (Clegg, 1997a). The driving cycle data was also used to estimate saving in fuel consumption and emissions reduction.

A comprehensive set of specifications for the system and in-vehicle integration was outside the scope of the present work. Instead a schematic representation of the proposed system has been produced, together with an explanation of operation and control concepts.

5. SCIENTIFIC AND TECHNICAL ACHIEVEMENTS

5.1 The choice of elastomer

Rubber is useful for many engineering purposes as it possesses a variety of useful qualities and properties. To determine the suitability of a material for use in an application the engineer must be aware of the physical properties and characteristics of the particular rubber type. Material properties of importance include tensile strength, stress relaxation, hardness, toughness, fatigue and hysteresis. The most important is hysteresis, as it represents the inherent inefficiency of the rubber.

There are various elastomeric stressing schemes which may be implemented to enable energy storage including tension, shear, compression and torsion. After due consideration the tensile mode was chosen, mainly because it is capable of storing more energy per unit of elastomer volume. The Instron Tensile Tester was used to measure the response of a sample to a tensile strain. A range of samples including natural rubber, black filled natural rubber, silicone rubber and neoprene have been characterised. Typical stress-strain data for a natural rubber sample is shown in figure 1(a). An initial set of selection criteria for the most suitable rubber were decided. These were:

- for an extension of 300 % or less since the system is constrained by the size of the vehicle
- a corresponding efficiency of at least 70 %
- maximum volume (105 kJ energy storage) for **unloading** condition at 45 litres.

Assuming the quantities scale directly as calculated, only two samples tested fulfil all three criteria, both being natural rubber. Although natural rubber may not withstand external influences as well as other rubber types, it is far superior in terms of the main characteristics we are interested in for this particular application. The device would need to be suitably engineered so that the rubber element is protected from weather conditions and vehicle fluids. The suitability of natural rubber is confirmed by previous research carried out in this field by the Eaton Corporation, and also the advice given by members of

professional organisations who specialise in Rubber Engineering, namely MRPRA and RAPRA Technology Ltd.

The theory of rubber elasticity (known as the Statistical theory) [2] is expressed in the following:

$$\sigma = F/A = G (\lambda - \lambda^{-2}) \quad (1)$$

where σ is stress, F is force, A is the cross-sectional area, G is the shear modulus and λ is the ratio of the stretched length to the initial length at any time. The energy stored per unit volume of the material under examination may be determined by integrating the above function with respect to λ ,

$$\frac{E}{V} = \int_{\lambda_1}^{\lambda_2} G \left(\lambda - \frac{1}{\lambda^2} \right) d\lambda \quad (2)$$

Comparison between theoretical and experimental data has shown that the theory describes the behaviour of most samples, and will be used to predict the behaviour of a full sized element.

5.2 Design concepts

Consideration has been given to all modes of energy storage and calculation of the forces involved, quantities of rubber required and ‘matching’ of the system e.g. number of rotations to twist or draw the system compared to number of revolutions of the wheels of the car and the corresponding distance travelled. The design chosen involves storing energy under tension as shown in figure 2. The vehicle is slowed by using the rotation from the drive axle of the wheels to rotate the winding shaft. As the inextensible wire is wound around this shaft the movable rack is displaced thus stretching the rubber. Maximum energy is stored when this rack is fully displaced. To accelerate the vehicle the system is released i.e. the winding shaft rotates in the opposite direction and the movable rack is pulled back to the relaxed position. To ensure that braking and accelerating are both in the same direction an extra gear wheel would have to be incorporated.

The elasticity theory discussed previously can now be used to predict the force-extension characteristics for a rubber component suitable for installation in the regenerative braking system. We have a total length of 1.5 m between front and rear wheel arch to accommodate a fully stretched system. To obtain an acceptable extension ratio ($\lambda=3.5$) the free length of the sample is 0.43 m and the extension is thus 1.07 m. If we let G equal 0.45 MPa and substitute into equation (2), the energy stored per unit volume of elastomer is calculated as $2.21 \times 10^6 \text{ J/m}^3$. We require an energy storage of 105000 J, which means that the volume of rubber necessary is 0.0475 m^3 . The corresponding cross sectional area A of the rubber is 0.111 m^2 . The force as a function of extension ratio is determined by substituting into equation (1) and the theoretical prediction for a full sized element is illustrated in figure 1(b). Such forces may require some reinforcement of the chassis but such consideration is outside the scope of this work.

The force from the rubber is applied to a 5 cm diameter winding shaft which is in turn connected via a gearing mechanism to the drive wheels of the car. The torque follows the force curve and the maximum is 4264 Nm. If the wheel diameter is 0.55 m then over a distance of 30 m the car wheels will rotate 17.4 times. To fully draw out the elastic system requires 6.8 revolutions of the winding shaft. For the system to be matched the ratio of the driven wheel torque to the winding shaft torque must be inversely proportional to the ratio of the revs. Values confirm that the system is reasonably well matched and could be practically feasible. Calculations have determined that if the braking distance varies, the system remains well matched but the torque and rev ratios vary accordingly. Therefore to achieve a practical regenerative braking system, the winding system would need to be operated through a gearbox with Continuously Variable Transmission (CVT) to obtain the complete range of gears required and for smooth operation.

5.3 System overview

The basic mode of operation of the system can be explained using the schematic representation shown in figure 3. In a conventional car with an automatic gearbox the accelerator controls the power from the

engine and this is regulated through the gearbox to the driving axle. The brakes act directly on the wheels to decelerate the vehicle. These concepts are maintained in our hybrid vehicle but we must also incorporate the hardware and software necessary to control and utilise the elastomeric energy store. The main components of the regenerative braking system are the elastomeric store which is connected to the winding shaft. Gearing between the winding shaft and the driving axle is achieved using a microprocessor controlled CVT. In addition we need some form of epicyclic gearing between the winding gear and the CVT. This may simply take the form of an extra gear wheel to maintain forward motion. The winding system can be locked by locking the epicyclic gearbox. The output from the gearbox and the output from the CVT would be linked to the drive axle through a clutch. This would allow either system to be decoupled from the drive but also allow smooth take up of imposed rotary motion when re-coupling.

System operation would be controlled by a network of sensors linked to an electronic control unit (ECU). A pressure sensor on the accelerator and brakes pedals would allow determination of the acceleration and deceleration levels required. Sharp depression of either pedal would override the regenerative braking system to allow for emergency braking or 'racing starts'. A position sensor on the movable rack of the elastomeric store would allow determination of the energy already stored or available for acceleration. The microprocessor on the CVT would be able to communicate directly with the ECU and from the calculated requirements the ECU would be able to select the appropriate gear ratio for the CVT. To allow the ECU to select the appropriate gearing for the direction of motion the 'epicyclic' gearing would be operated by an electronic switch. The ECU would continuously monitor all sensors to ensure for example that when the energy store is depleted the fuel supply and engine are switched on. Similarly when the energy store is full the ECU must be capable of switching in the conventional braking system.

5.4 Vehicle performance characteristics

In order to determine the compatibility of the regenerative system with the performance of a conventional engine we need to predict the performance characteristics of the elastomeric propulsion system. The predicted force-extension characteristics of a full sized rubber element illustrated in figure 1(b) can be used to predict the propulsion characteristics. In order to propel the car a reasonable distance as the rubber is released, the introduction of suitable gearing between the winding and driving shaft is necessary. The gear ratio is determined by the ratio of the number of revolutions of the winding shaft to fully extend (release) the rubber system and the corresponding number of wheel revolutions to ensure a suitable distance is travelled. When the rubber extension is a maximum, the distance travelled is also a maximum. The maximum rubber extension is 1.07 m and we will set the minimum distance over which the stored energy is used at 40 m. The diameter of the winding shaft is 0.05 m and the diameter of the car wheel is 0.55 m. This gives a rev ratio (car to rubber) of 3.4 : 1. Using this value we can determine the incremental distance travelled as a function of the extension of the rubber. The effect of introducing a gear to increase the distance travelled is to reduce the force available to propel the vehicle. The corresponding force is determined from the torque ratio (car to rubber). The torque ratio is inversely proportional to the rev ratio. At maximum extension the torque ratio is 1/3.4. Using this data we can determine the incremental values of the force at the car wheel from the force supplied by the rubber. From this the acceleration of the vehicle can be determined as a function of distance travelled, and in turn the acceleration and distance travelled yield the velocity and hence the total journey time. Using the equation (2) the incremental energy storage per unit volume as the rubber is stretched can be calculated. From a knowledge of the volume the incremental energy stored in the rubber element can be quantified. The energy used is the total energy minus the energy stored. Power as a function of velocity can then be determined. A data sample is shown in Table 1.

If the distance is changed the gear ratio is altered. This in turn affects the time and power characteristics. If we set top gear such that the acceleration distance is 160m the rev ratio (car to rubber) is 13.6 : 1. This represents a span of 4 : 1 between top and bottom gears and is comparable to conventional gearboxes (including CVT). Thus we can repeat the above calculations substituting 160 m for the distance travelled to determine the limiting performance. In addition to this it might also be

possible to use the energy store when in motion, to boost the speed of the vehicle. To this end we must also consider how the speed would increase for a particular initial speed throughout the range. Consider the case where the car is travelling at 4.5 ms^{-1} (10 mph) and we implement the energy store. The car has a kinetic energy of 12150 J. The energy store will provide an additional 105000 J, giving a total kinetic energy of 117150 J. The final speed of the vehicle is then 13.97 ms^{-1} . This process can be repeated for speeds of 20, 30, 40, 50, 60 and 70 mph. Calculations have been repeated for each speed increment using both top and bottom gear ratios to illustrate the performance limits. The data has been amalgamated to produce a graph of driving force as a function of speed for the range of initial speeds. This is shown in figure 4(a). Also shown in bold are the net tractive effort curves for a conventional three speed engine [3] to assist in determining whether the elastomeric system will have the ability to propel the vehicle. The graphs suggest that the elastomeric system is capable of providing the necessary driving force.

5.5 Reduced engine size

A conventional engine alone can obviously meet the driving requirements placed upon it throughout a typical driving cycle. Incorporating a regenerative braking system into a car with such an engine will create benefits in terms of fuel savings and reduced emissions, but would still add to the manufacturing costs of the vehicle. To achieve even greater savings in fuel and emissions, it would be beneficial to reduce the engine capacity. This may also reduce the cost of the engine thus offsetting the extra cost of installing the elastomeric energy store. However the engine performance combined with that of the regenerative energy store must still be capable of achieving the necessary driving requirements. We now consider an engine where the tractive effort (hence available power) for each gear is one half the former value. The data derived previously for the characteristics of the regenerative braking system can now be compared with those of the 'new' engine. The results are shown in the graph of figure 4(b). The 'new' engine performance curves are shown in bold and it can be seen that the characteristics are more closely matched.

The initial idea of reducing the engine size was that the elastomeric energy store could be used in conjunction with the engine to supplement power when required. It was found that invoking the energy store gives a large initial power boost which rapidly tails off. In practice, such a rapid boost would be unacceptable and a (clutch) mechanism would have to be installed into the system to allow a much smoother take up of the energy. An alternative method of utilising this system would be to use either component in isolation but combine the two if power requirements dictate. The engine would be automatically switched off when the energy store is required. For braking and coasting events, when the energy store could be regenerated, the engine would be switched off. When the energy store is empty the engine would be used to supply the power required. Such use of the system would depend on the power requirements of the particular driving cycle.

5.6 Driving cycle studies

To determine whether the regenerative braking system is capable of achieving the acceleration and deceleration rates encountered on a typical journey, three driving cycles have been studied. These are the US Environmental Protection Agency (EPA) urban cycle [4], the EPA highway cycle [4] and a hypothetical mixed cycle [5]. The energy required to accelerate or lost when braking has been calculated, together with the distance travelled over each section. The energy balance within the elastomeric store for each stage of the journey has also been determined to assess when power from the engine is required. It was found that for each cycle the majority of sections can be achieved using the energy store as the sole means of propulsion. This data is not a true representation of the energy transfer. As with any mechanical system there will be losses associated with the gearing, clutch mechanism and friction, not to mention the inherent hysteresis of the rubber. The energy loss over a complete cycle was assumed to be 66 %.

The energy store over each cycle was recalculated to take into account these losses. Surprisingly the loss factor does not make very much difference. Extra power boosts from the engine are required for the

Urban and Highway cycles and the total extra power required overall from all boosts is higher for all three cycles. In order to determine whether the reduced power engine could produce the supplementary power boosts required, the initial and final boost speed and time taken was compared with the speed-time characteristics for each gear of the reduced power engine. In all cases for each cycle the power boosts required are well within the capability of the reduced power engine. Extra power could be achieved by combining the energy from the two components. However this has not been necessary for the three driving cycles considered here.

Consideration of the state of the elastomer at any stage in the driving cycle determined the gear ratio necessary to achieve the required performance. The major limitation for this system was found to be in the value of this ratio between the driven wheel and the winding shaft. In some cases it would be impossible to achieve with a conventional gearbox. In addition to achieve every stage a gearspan of 16 would be necessary. A custom built reduction gearbox would be one solution to the problem, but would add to the overall cost of the system.

5.7 Fuel consumption

The fuel consumption depends on whether the vehicle is either idling, cruising at a constant speed, accelerating or decelerating. An appropriate expression is then used to calculate the fuel consumption for that state [6,7]. The fuel consumption was calculated for each stage of the three driving cycles considered previously. In order to compare the fuel consumption of a conventional car with the fuel consumption of a similar vehicle fitted with the elastomeric regenerative braking system (ERBS), the following assumptions were made. For the conventional car, the fuel consumption for each 'state' has been calculated according to the above data. For the car fitted with the ERBS the fuel supply is interrupted whenever the ERBS is in operation (stretch and release). For the constant velocity stages, the power is supplied by the engine and the fuel consumption is calculated accordingly. If the savings shown in Table 2 could be achieved such a system would be of great interest to the car user.

5.8 Emissions

The corresponding pollution emissions over the three driving cycles has also been determined. The following three pollutant emissions are estimated: Carbon Monoxide (CO), Nitrogen Oxides (NOx) and unburned Hydrocarbons (HC). These quantities are obtained from look up tables which give the amount of pollution emitted according to the speed and acceleration of the vehicle [8]. The assumptions made previously apply. For the conventional car, the emissions produced for each 'state' has been calculated according to the above data. For the car fitted with the ERBS the fuel supply is interrupted whenever the ERBS is in operation (stretch and release). Since no fuel is used, no emissions are produced over these stages. For the constant velocity stages, the power is supplied by the engine and the emissions are calculated accordingly. Again, if the savings shown in Table 2 could be achieved, such a system would be of great interest to environmentalists.

6. RELATED WORK

Research into elastomeric regenerative braking systems was carried out by the Eaton Corporation in 1982 and the MRPRA in the 1960's. To date, nothing further has been published in this subject area. Work continues world-wide on hybrid vehicles which incorporate more conventional regenerative braking systems. The objectives of increased fuel efficiency and zero emissions are now combined with the search for alternative fuel sources.

7. DISSEMINATION

The involvement of the children in this research project was featured in the EPSRC publication '*Cleanline6*', November 1996. An exhibition was held on 1st July 1996 at a school open evening to display the results of the project. A report on this was also published in the local newspapers, the Wharfedale Observer and the Wharfe Valley Times.

A paper was presented at the Universities Transport Studies Group (UTSG) Conference held in Bournemouth in January 1997 (Clegg, 1997b), and a second paper is to be presented at the 30th International Symposium on Automotive Technology and Automation being held in Florence, Italy in June 1997 (Clegg, Kirby, Duckett, Crolla and Dougherty, 1997).

Copies of the ISATA paper will also be sent to contacts at the Motor Industry Research Association (MIRA), the Malaysian Rubber Producers Research Association (MRPRA) and the Rubber and Polymer Research Association (RAPRA) who have provided assistance and shown interest.

8. CONCLUSIONS AND RECOMMENDATIONS

From this initial study, the development of an elastomeric regenerative braking system does appear to be technically feasible. The present findings confirm that natural rubber is the most suitable material and show that a total volume of approximately 45 litres will be sufficient to store the equivalent kinetic energy of a car travelling at 30 miles/hour. Improvements in the properties of the elastomer would enhance the prospects of such a system through volume and weight reduction. It would appear that the most promising system would use rubber under tension, although this is not common in engineering applications due to the safety implications. Appropriate consideration would have to be given to the effects of failure and trials carried out as required.

A theory which describes the elastic behaviour of rubber has been used to predict the size, storage capacity and force-extension characteristics of a rubber element suitable for incorporation into the regenerative braking system. The predicted rubber characteristics have been compared with the known characteristics of a conventional engine in terms of tractive effort and resistance as a function of speed. The results show that the tractive effort produced by the elastomer is capable of matching the characteristics of the engine considered in this work. Rates of input and output energy have also been calculated to determine the process of energy storage and retrieval throughout a typical driving cycle. The energy store appears to be capable of reproducing many stages of the three driving cycles considered. In order to increase the overall savings achieved by the system, the engine was 'replaced' by one with reduced power. This engine was sufficient to supply the extra power boosts as required.

Fuel consumption and emissions have been shown to be drastically reduced. If these values could be achieved in practice, the benefits of such a system to both the car user and the environment are immediately apparent. Although the values do appear to be rather high, a more realistic value could be achieved with further experimental work and prototype development, however this is outside the scope of this work. As a first approximation these values look very promising and should justify further research and development of this system.

In order to ascertain the practical viability of such a regenerative braking system, a complete assessment of all costs likely to be incurred must be carried out. These costs must be compared with the benefits brought about through fuel savings and reduced pollution emissions. One must also consider the lifetime of the device i.e. number of cycles to failure, and how this equates to real life usage. Such considerations are outside the scope of the current work, but as expressed previously the device looks promising enough to justify the further research and development required.

Significance of results in relation to current engineering practice

The development of an elastomeric regenerative braking system as presented in this research appears to be technically feasible. However persuading vehicle manufacturers to invest time and/or money in the development of such a system has, as yet, not been achieved. Before a prototype system can be built, it is generally considered that more advanced modelling is necessary. Such work must take into account features which include:

- producing a more detailed picture of the mechanical operation of the energy store

- combined operation of the braking system with the conventional components
- fuel consumption and emissions depending on the gearing and condition of the engine.

In the light of this present work, the authors consider that the possible benefits would justify the investment required for these next stages.

9. PUBLICATIONS AND CONFERENCE PAPERS

Internal Reports

- CLEGG, S.J. (1996a). A review of regenerative braking systems. *ITS Working Paper 471*, Institute for Transport Studies, University of Leeds, Leeds.
- CLEGG, S.J. (1996b). Design of an elastomeric regenerative braking system. *ITS Technical Note 404*, Institute for Transport Studies, University of Leeds, Leeds.
- CLEGG, S.J. (1997a). Vehicle performance characteristics. *ITS Technical Note 405*, Institute for Transport Studies, University of Leeds, Leeds.

Conference papers

- CLEGG, S.J. (1997b). An elastomeric energy storage system to improve vehicle efficiency. *Paper presented at the Universities Transport Studies Group 29th Annual Conference*, held in Bournemouth, January 1997.
- CLEGG, S.J., KIRBY, H.R., DUCKETT, R.A., CROLLA, D.A. and DOUGHERTY, M.S. (1997). Elastomeric propulsion for the hybrid vehicle of the future. *Paper to be presented at the 30th International Symposium on Automotive Technology and Automation*, to be held in Florence, Italy in June 1997.

10. OTHER REFERENCES

- [1] HOPPIE, L.O. (1982), The use of elastomers in regenerative braking systems, *Rubber Chemistry and Technology*, **55**(1), pp 219-232.
- [2] TRELOAR, L.R.G. (1975). *The Physics of Rubber Elasticity*. Oxford University Press, UK.
- [3] WONG, J.Y. (1993). *Theory of Ground Vehicles*. John Wiley and Sons, Canada.
- [4] BLACKMORE, D.R. and THOMAS, A. (1977). *Fuel Economy of the Gasoline Engine*. Macmillan Press, UK.
- [5] GERLOUGH, D.L. and HUBER, M.J. (1975). *Traffic Flow Theory: A Monograph*. Transportation Research Board, USA.
- [6] FERREIRA, L.J.A. (1982), Car Fuel Consumption in Urban Traffic. The Results of a Survey in Leeds using Instrumented Vehicles. *ITS Working Paper No. 162*, Institute for Transport Studies, University of Leeds.
- [7] DEPARTMENT OF TRANSPORT (1991). *New Car Fuel Consumption: the official figures*. UK Department of Transport, London.
- [8] QUARTET Deliverable No.2 (1992). NEMIS User Manual.

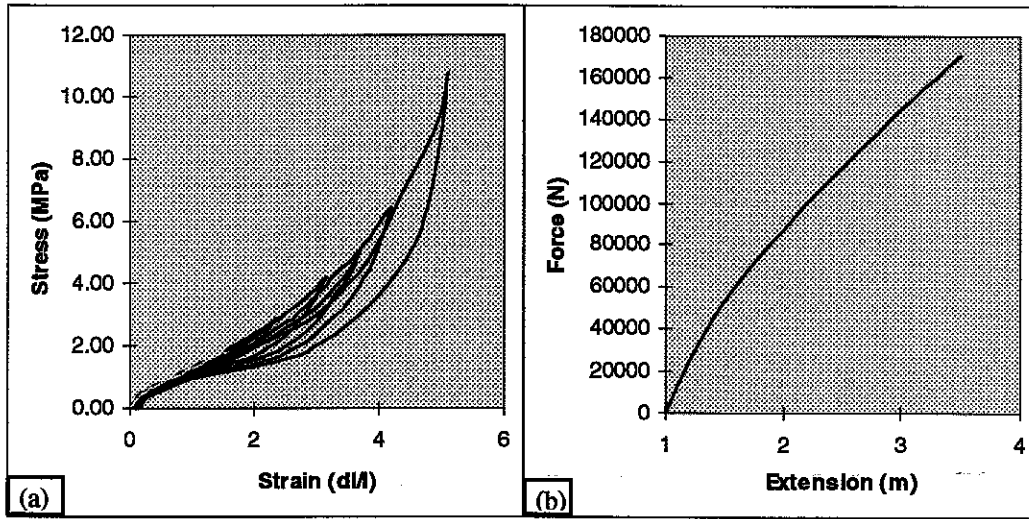

Figure 1: (a) Stress as a function of strain for a natural rubber sample
 (b) Theoretical force as a function of extension ratio for full sized rubber element

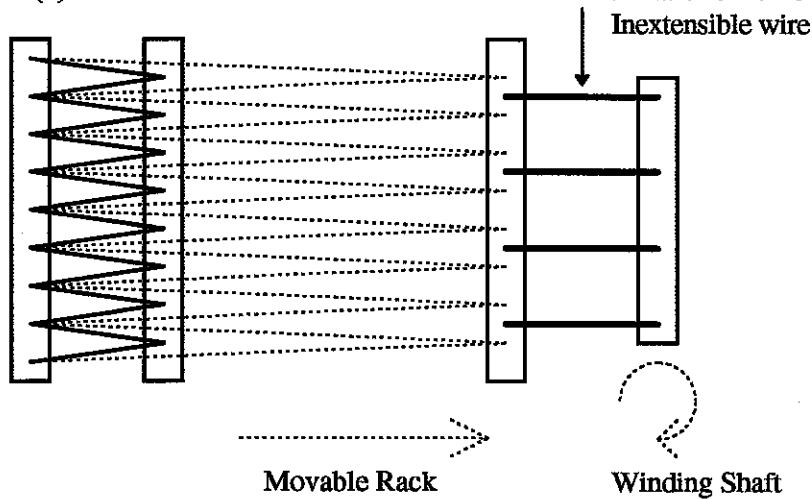

Figure 2: The proposed braking scheme

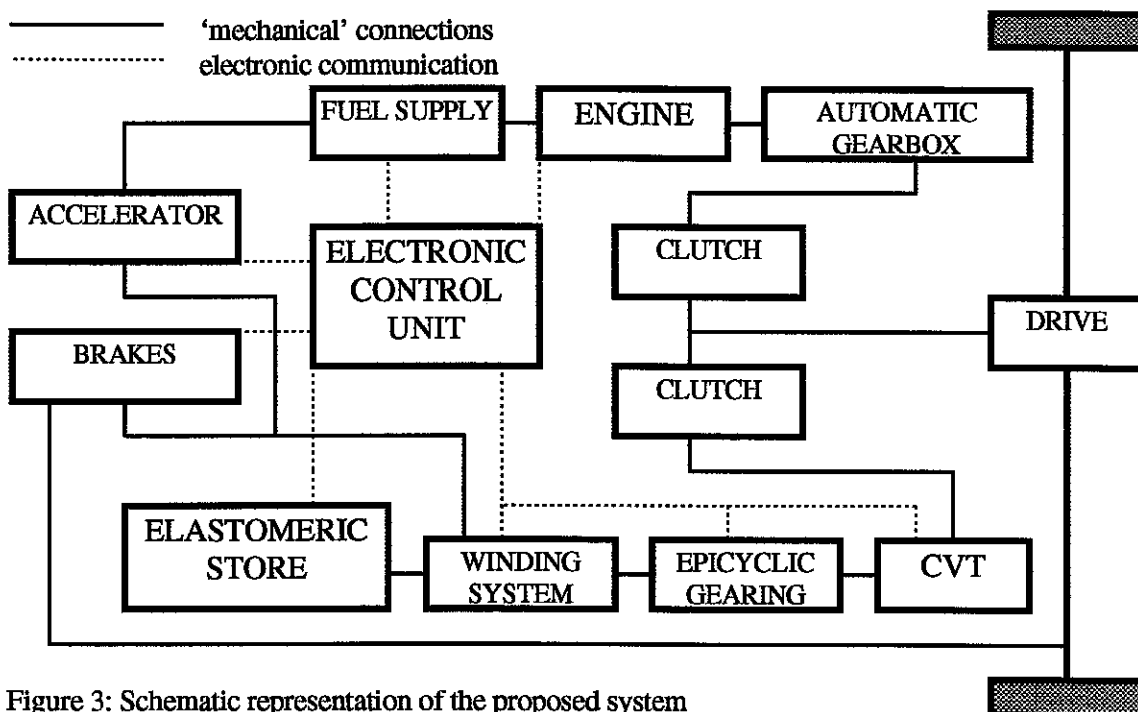

Figure 3: Schematic representation of the proposed system

Table 1: Propulsion characteristics from the elastomeric store

λ	Extn (m)	Release Force (N)	Release dist (m)	Car force (N)	Accn (m/s ²)	Speed (m/s)	Time (s)	Energy Used (J)	Power (J/s)
1.0	0.00	170545	0.0	4568	3.81	0.00	0.00	0	0
1.2	0.09	160059	3.2	4287	3.57	4.82	1.32	14169	10744
1.4	0.17	149470	6.4	4004	3.34	6.71	1.87	27436	14646
1.6	0.26	138751	9.6	3717	3.10	8.07	2.31	39789	17256
1.8	0.34	127862	12.8	3425	2.85	9.16	2.68	51217	19132
2.0	0.43	116745	16.0	3127	2.61	10.05	3.01	61702	20498
2.2	0.51	105318	19.2	2821	2.35	10.79	3.32	71221	21470
2.4	0.60	93458	22.4	2503	2.09	11.41	3.61	79744	22117
2.6	0.69	80973	25.6	2169	1.81	11.92	3.88	87225	22483
2.8	0.77	67551	28.8	1809	1.51	12.34	4.14	93598	22590
3.0	0.86	52663	32.0	1411	1.18	12.66	4.40	98764	22451
3.2	0.94	35337	35.2	947	0.79	12.89	4.65	102558	22058
3.4	1.03	13648	38.4	366	0.30	12.99	4.90	104699	21382
3.5	1.07	0	40.0	0	0.00	12.99	5.03	105000	20875

Table 2: Summary of fuel savings and emissions due to regenerative braking system

Cycle	100 % Efficient			With losses		
	Conventional	Car/ERBS	Savings	Conventional	Car/ERBS	Savings
Urban	477.37	187.21	61%	477.37	196.22	59%
Highway	588.64	179.71	69%	588.64	222.60	62%
Mixed	441.08	161.20	63%	441.08	165.92	62%

Cycle	CO savings		NOx savings		HC savings	
	Efficient	Losses	Efficient	Losses	Efficient	Losses
Urban	67 %	63 %	63 %	60 %	69 %	66 %
Highway	66 %	55 %	61 %	50 %	69 %	60 %
Mixed	66 %	65 %	69 %	68 %	75 %	74 %

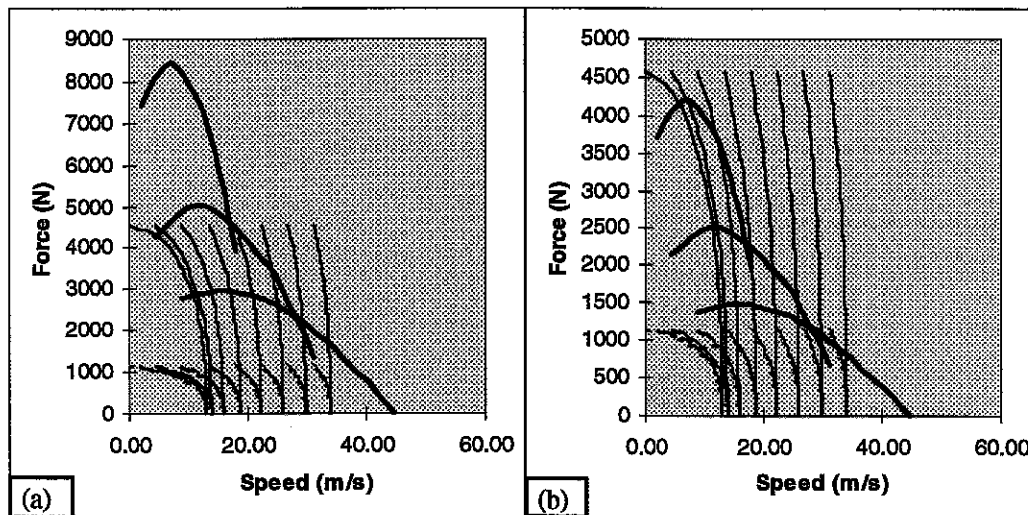

Figure 4: Driving force as a function of speed for the range of initial speeds for (a) the conventional engine and (b) the reduced power engine