

**Same Polytechnic College  
Tanzania Build 2022 ARCE Senior Project  
Spring 2022**

Student Team: Paulina Robles, Anna Yamauchi, Surina Marwaha, Tia Kelly, Dillon Schneider, Audrey Hoang, Connor Gilligan, Jennifer Viveros, Jenna Beutelschies, and Robert Hardwick

Project Advisors: Kevin Dong, Tom Fowler

**Table of Contents**

Background	2
Project Description and Goals	3
Architectural Overview	4
Structural Overview	5
Structural Detailing	6
Scheduling and Cost Estimates	8
Prototyping	9
Design Documentation	11
Impact	12
Reflections	13
Bibliography	14

## Background

In collaboration with The Mbesese Initiative for Sustainable Design, the Cal Poly senior project team has designed, engineered, and prepared construction documents for a new vocational training college in Same, Tanzania, a rural area in the Mt. Kilimanjaro region. Upon its completion, the college will offer quality and practical educational opportunities for up to 1,200 students; in the interim, individual structures will be occupied immediately, adding value to the community throughout the construction process. The campus will house continuing educational programs, sports and agriculture fields, as well as hotels and other community-facing structures.

The Mbesese Initiative for Sustainable Design (MISD) is a non-profit organization with the goal of alleviating poverty through access to education in East Africa. MISD believes that change can be driven through building human capital, encouraging economic growth, improving the built environment, and fostering environmental stewardship<sup>1</sup>. These tenets are central to the vision behind the Same Polytechnic College.

The town of Same is located in the rural highlands of Northern Tanzania. Just south of the equator, Same experiences strong sunshine and heavy monsoons throughout the year. The main rainy season on the coast is from March to May, with a second season between October and December. Over the course of the year the temperature varies from 60°F to 89°F, and on average the humidity is 86%. However, due to climate change, the alteration of patterns in temperature, rainfall, solar radiation and winds perpetuates higher temperatures and more frequent droughts.

The education system in Tanzania operates through a 12 year sequence of schooling in which students take rigorous national tests every few years, followed by an advanced certificate exam, and college for 3-4 years. This system is daunting, as most students cannot make it past secondary school because of malnutrition, obstacles in transportation, and cost of attendance. In addition, instruction switches from Swahili to English after the first 7 years, creating a large roadblock to students looking to continue their education. Even so, most college graduates are past age 34 before securing a job. The Same Polytechnic College aims to help students gain the practical skills they need to get a higher socio-economic level job, while understanding that many Tanzanians do not have the educational level or resources to get into college.

The Same Polytechnic College will provide tertiary education and vocational training to help individuals develop the knowledge and skills necessary to achieve these various objectives. The project has been in the hands of Cal Poly students since roughly 2011, with contributions from over 600 students throughout the past decade. David Lambert, structural engineer for Arup and co-founder of MISD, has been working with students to provide guidance and feedback during the design process, helping to inform decisions about material use and constructability. Notable accomplishments of previous senior project groups include: constructing a steel truss bridge to enable K-12 students of Same, Tanzania a safe path to school, along with a prototype structure for the classroom building. Additionally, schematic designs have been developed in past years by senior project groups for the Same Polytechnic College classrooms. The most

recent designs, prepared by students of the graduating class of 2020, included architectural renderings and schematic designs. Sadly, the project was left incomplete due to the COVID-19 pandemic.

### **Project Description and Goals**

In January of 2022, a 16-person multidisciplinary student team resumed work on the Same Polytechnic College with limited documentation from the previous senior project group. Although the general concept and layout were established, initial research was conducted to either confirm design decisions or inspire further investigation. In the coming months, students made dramatic changes and progress on what will become “phase zero” of the master plan. Phase zero consists of four modules wrapped around a central courtyard, a schematic design passed on from the 2020 senior project class which draws inspiration from the native acacia tree and the shade it provides Tanzanian people. Each module consists of a canopy created by sloping trusses and posts, which creates an open plan that is reflective of common architectural styles of the region (*see Figures 1 and 2*).

At the outset of the project, studies on the local climate including prevailing winds, precipitation, heat gain, and a sun path analysis were performed; torrential rain and high temperatures were major factors in developing the early architectural and structural designs. Poorly ventilated metal deck structures collect heat like a closed car; passive ventilation was promoted by orienting the clusters to direct wind through large openings in the partition walls and through the truss space. The truss canopies will also provide shading to a central courtyard in which students can convene outside of classes and events, as shown in figure 4. The canopy structure is sloped to direct rainwater to flow away from the interior courtyards and into freshwater holding tanks. Metal decking covering the roof will be lapped and covered with sound-deadening material in order to ensure torrential rain does not cause disturbances to classes and events in the college. Located in a region with very little seismic activity, the lateral force resisting system design is governed by wind and is addressed by a steel braced frame system that is integrated into the steel connections to the wood framing system.

Many of the design components of this project were inspired by a collection of international precedents. The most notable include the Children’s Village located in Brazil, the Primary School in Ulyankulu, the Gando Primary School Library, and the Nest We Grow located in Japan. These precedents specifically influenced our connections, finishes, and layouts of outdoor spaces in the project, in which we melded western and non-western construction techniques and architectural styles.

As part of the design development, the structural system was optimized. The grid pattern schemed by the 2020 team was spaced at 8 feet (*Figure 1*), and was stretched to 12 feet (*Figure 2*) square. The resulting structure would use less materials and offer a lighter feel. However, the team had to be aware of the larger spans and tributary areas as key decisions were made.

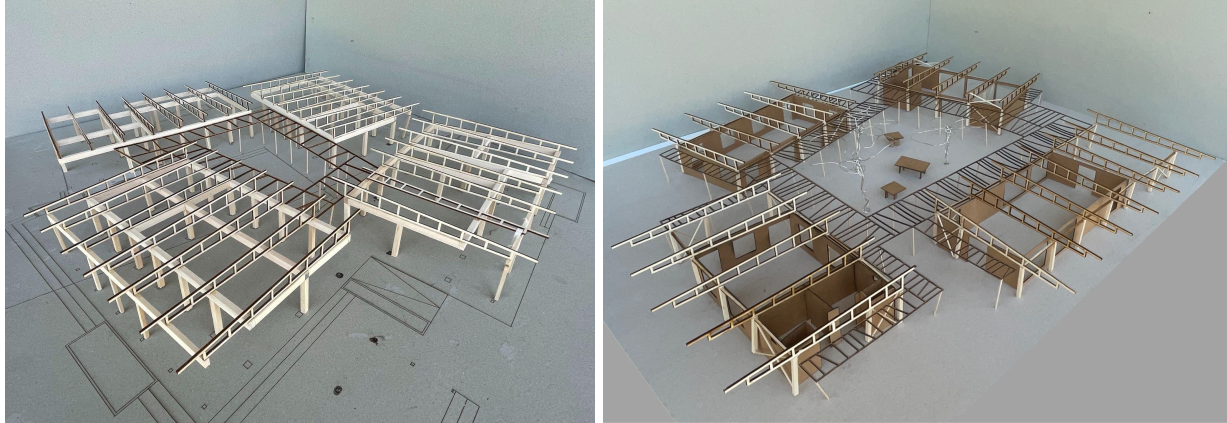


Figure 1: Original Structural Layout (left), Optimized Structural Layout (right)

Mock-ups of structural members, such as concrete columns, hybrid trusses, and steel connections were built to confirm that these designs were feasible using the materials, means, and methods available in Same, Tanzania. The strict constraints and construction conditions dictated many decisions. The prototypes ensured that designs are economical and feasible in terms of constructability. Construction plans and documents must be prepared with a language barrier in mind, and with a respect for the current building practices of the community. Students prepared details and plans for both permitting and as construction documents. Drawings for use on site will be diagrams of construction methods and connection details, for ease of communication with local builders and to ensure a standard of construction practice. Note in the images below there are little to no instructions or written identifiers, color coding helps visualize material, and all dimensions are clearly labeled.

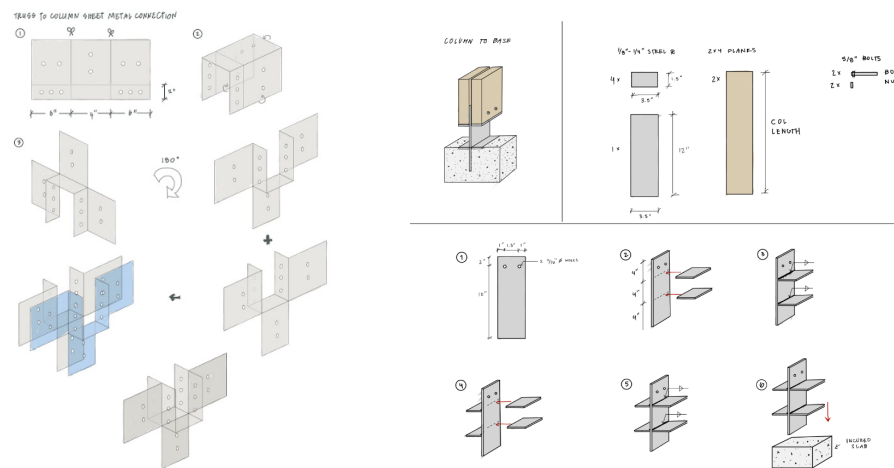


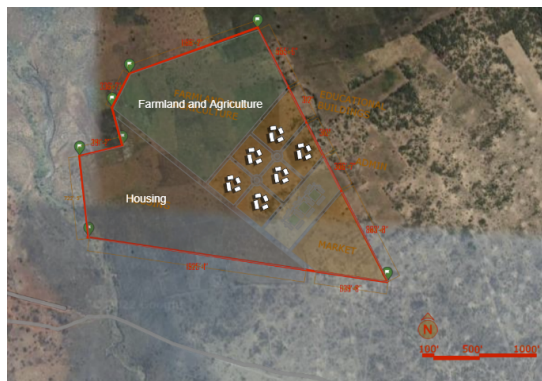
Figure 2: Example Connection Details

In the summer of 2022, a team of architectural engineering students will have the opportunity to travel to Tanzania to finally break ground on the Same Polytechnic College using the construction documents and methods of construction established during the 2021-22 school year. Over two weeks, students will construct one full module that can immediately begin use as a classroom and community space.

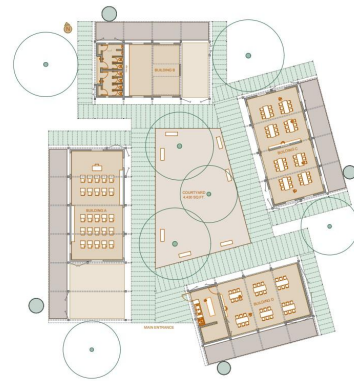
## Architectural Overview

In order to design the modules structurally, the team relied heavily on a group of six architecture students at Cal Poly advised by Professors Dong and Fowler. Their contributions include reorganizing the modules to enhance circulation, creating a revised courtyard configuration, establishing room sizes and programming spaces for multiple uses, as well as determining wall openings sizes and locations to enhance interior daylighting and natural ventilation.

The vocational school will consist of six colleges with disciplines such as construction, agriculture, and tourism, which will benefit the Tanzanian economy. The land will be divided into different sections for student housing, farmland, and a cluster of buildings for each college (*Figure 3*). One example of a cluster layout is shown in *Figure 4*. The structures are oriented to allow for views of the nearby mountains, and spaced apart to create a courtyard in which students can gather.

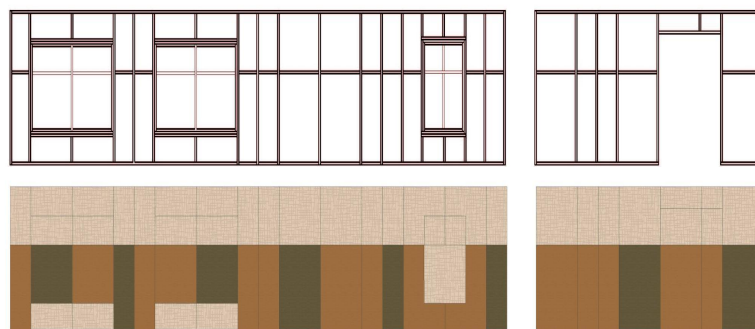


*Figure 3: Site Plan in Same*



*Figure 4: Building Cluster Layout*

It was important to honor traditional Tanzanian architecture and craftsmanship, both through design and sourcing of materials. The partition walls will be timber-framed with panels made of plywood and sisal-woven fabric, which is a breathable material made locally (*Figure 5*). This color palette was inspired by textiles and patterns commonly found in Tanzania.

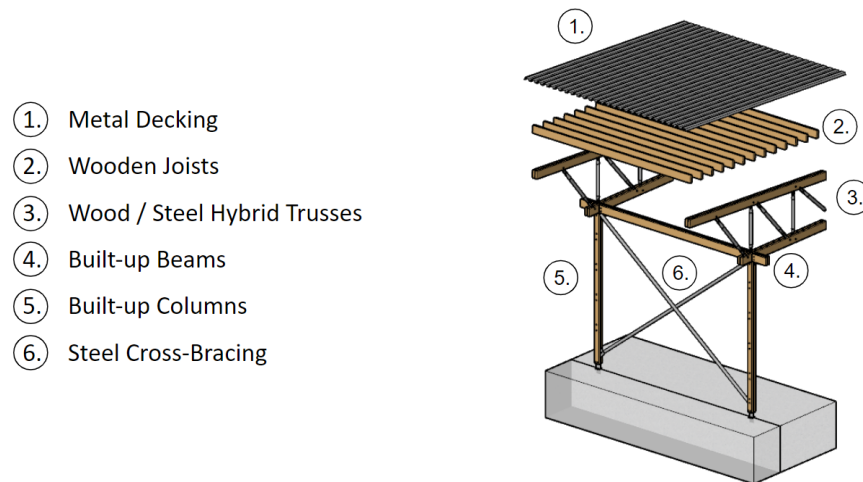


*Figure 5: Partition Wall Framing (above) and Panel Color Palette (below)*

## Structural Overview

The primary structural focus was in the canopy structure covering the partition walls beneath. Because these walls were considered non-structural and detached from the canopy, the truss structure acts as the gravity and lateral force resisting system. It is important to note a few changes that were made from the original concept to the final design and what factors impacted these decisions before describing the structural system. These two considerations were the element size for all structure members including trusses, columns, and beams, and the bay sizes that created a dense structural system, despite oversized members. Early explorations revealed the structure takes very little gravity load thanks to exposed framing and a lack of conventional mechanical equipment. Additionally, there is little lateral load due to Same being in a low seismic zone and the open structure resisting minimal wind force. With both of these factors in mind, member sizes were drastically reduced, bay sizes were expanded, and the trusses were cantilevered, all of which made more efficient use of the gravity system.

The vertical force resisting system consists of metal decking (1) spanning between wood joists (2) which are supported by wood-steel hybrid trusses (3). Gravity loads travel through the truss spans into wood built-up columns (5) and into the foundation (See *Figure 6*). The gravity load path follows the reverse order of the construction sequence, making it easy to follow the order of installation.



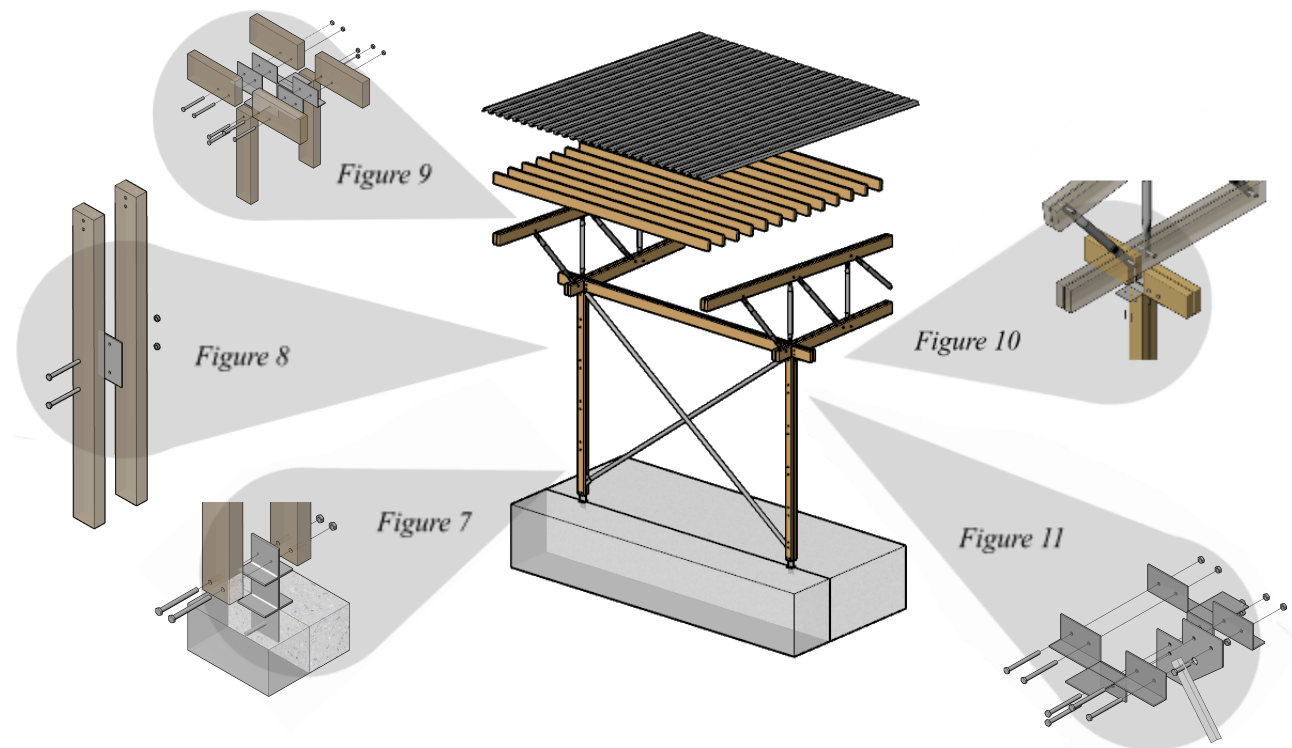
*Figure 6: Exploded Structural Framing*

Due to the minor seismic demand and small surface area of the canopy structure, the lateral forces will be small. Thus, a simple diagonal brace system can be used and the trusses with metal decking will act as a flexible diaphragm. Wind, being the dominant lateral force condition, acts over the exposed truss faces along the short sides of the building and over the projected surface area of the roof over the long sides of the building. Shear force is carried through the diaphragm to a line of drag beams (4) which connect at the truss-to-column connection and drag lateral force into simple braced frames (6) that take the load into the foundation (See *Figure 6*).

## Structural Detailing

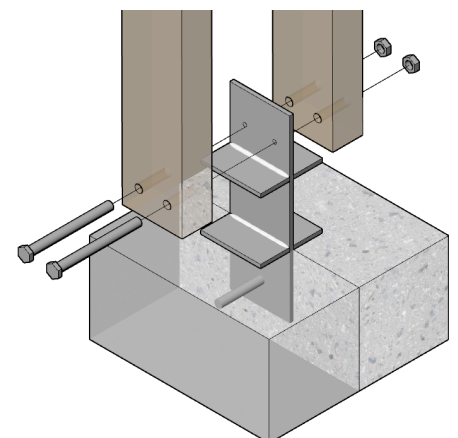
The overarching goal of member and connection design was to ensure the anticipated global behavior occurs for both lateral and gravity load paths. Within the confines of that goal, connection details were developed to be easily constructed with local materials and tools, to enable a proper sequence of construction, and to create a cohesive architectural motif.

Due to the lack of availability of larger timber sections, the decision was made to use members built-up with two 2x sections. A natural extension of this decision was to contain steel connections in the gap between members — wood truss chords will hide steel pipe webs, columns will hide the foundation and truss connection, and drag beams will hide their connections to the columns. A reveal between members will result from this placement of steel connections, and will be an architectural feature of this project. Below is a typical bay diagram with each of the details covered in this section called out for organizational purposes.



The decision to conceal connection details inside of the structural framing required that careful attention was paid to their design. The following details were optimized for the load path they support, for simplicity of fabrication, to enable a straight-forward construction sequence, and to keep with the general structural motif.

The connection of the column to the slab is designed to elevate the column base from the top of the slab to avoid rotting due to moisture on the ground (*Figure 7*). Tabs welded onto the vertical plate provide two functions; at the bottom to help with leveling during construction, and at

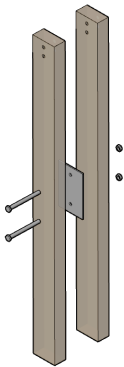




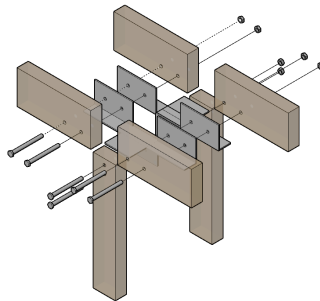
the top to protect the bottom of the column from damage. A bearing pin is welded onto the portion of the plate embedded in the concrete slab to transfer gravity loads into the strip foundation

Along the length of the column, bolts with gap plates are provided to ensure the built-up section acts as one member (*Figure 8*). At the top of a column, a folded plate connection is used to join the drag beams, truss, and columns (*Figure 9*). For gravity loads, this detail provides a positive connection between the truss and the column, and provides for uplift restraint. For lateral loads, a continuous band of steel provides a direct load path between drag beams, bypassing the column and truss.

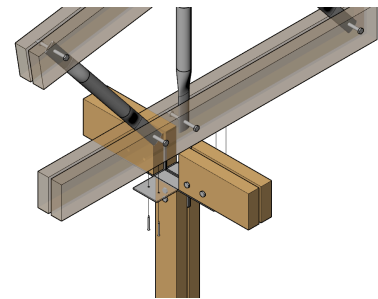
*Figure 7: Column Base to Foundation*



*Figure 8: Column Gap Plate*



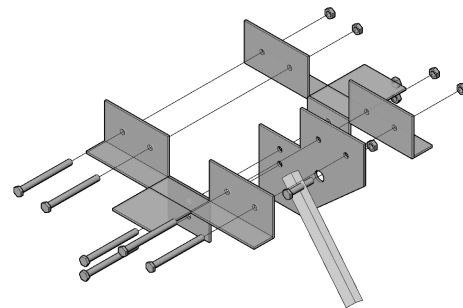
*Figure 9: Drag Beam to Column*



*Figure 10: Truss to Column*

This connection was also designed to promote an ideal construction sequence. The column can be fully assembled on the ground, then raised into place with temporary bracing. Next, drag beams can be bolted on, connecting the newly erected column to a braced line. Finally, a truss can be lowered into the gap between two drag beams and secured with screws from below (*Figure 10*). This construction sequence minimizes the need for temporary bracing and encourages construction tasks to be done in parallel, as trusses can be constructed while columns and beams are being raised.

Another critical detail is the connection between the column-truss-beam nodes and a brace mounting point. Continuing with the theme of concealed connections between built-up sections, the brace connection plate aligns with mounting holes for the drag beam and gravity column (*Figure 11*). The critical component of this connection point is the interface with the drag beam mounting points as these will allow horizontal forces to travel into the diagonal brace members. This plate will need to be installed alongside the drag beams because of the alignment of bolts, but the pin connection where the brace mounts will remain exposed for installation of the brace frame at any point.

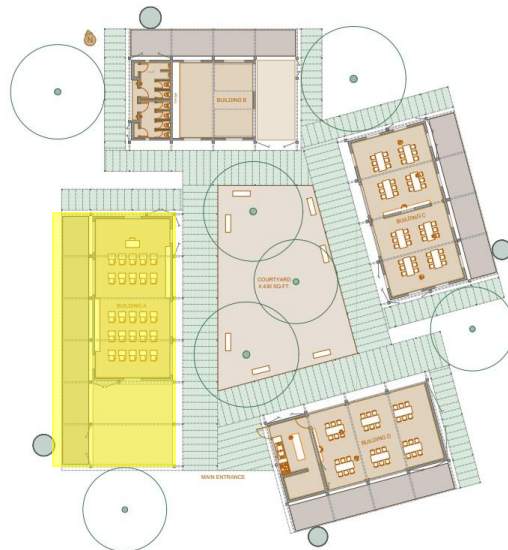


*Figure 11: Brace Connection at Beam-Column Node*

## Scheduling and Cost Estimates

The objective of the scheduling and cost estimates team was to give the project team information on the economic and scheduling feasibility of the structural systems in consideration. The cost and scheduling study analyzed three major components for two structural systems. The first system utilized concrete columns while the second used timber built-up columns; the rest of the structural framing was identical between the two options. The three components considered for each structural system were the following: a quantity take-off, construction schedule, and cost estimate.

The quantity take-off was based on a singular module of the whole college cluster. The classroom module, highlighted in Figure 12, was chosen due to its versatility in use. The space could be used in between building trips by the locals, by volunteers for workshops and community outreach programs, and as storage for building materials during construction of other units.



*Figure 12: Site Plan of College Cluster*

Two construction schedules were created for each of the two structural systems mentioned above. The estimated schedules do not include various components such as water tanks, gutters, or any ceiling finishes; however, they do include the wall finishes as well as door and window installation. Furthermore, an assumption was made regarding the size of the team in order to create the schedules. The assumption is that the construction team would consist of the complete senior project group of 12 students/faculty and 4 paid local workers from Tanzania.

To begin creating the schedules, goals for the construction process were determined:

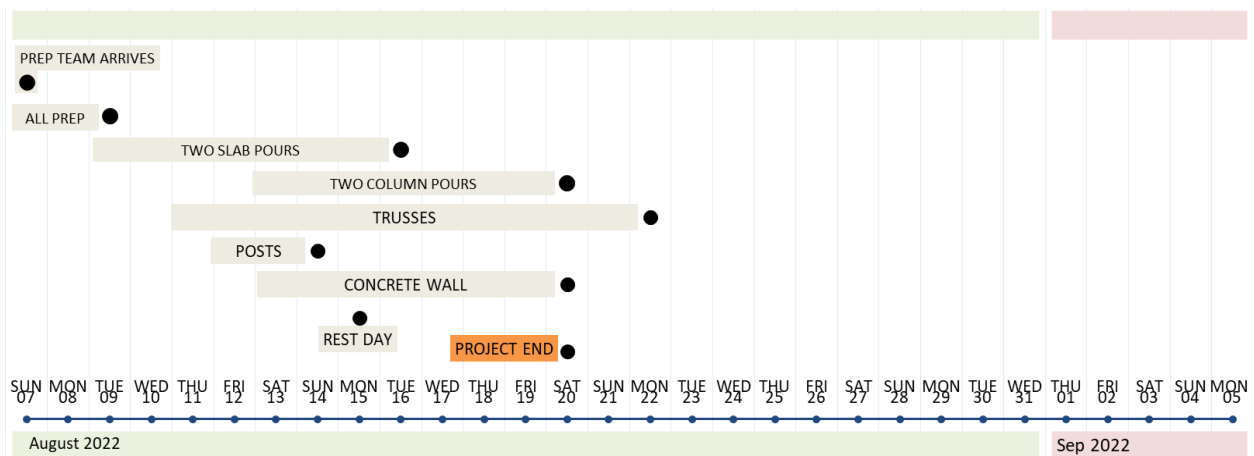
- Complete module in twelve work days with one day of rest
- Minimize cost
- Minimize waste
- Consider constructability and construction quality

- Complete module with twelve volunteers and four paid work workers
- Define man-days required per task

After the goals were identified, the schedules were not overly complicated to construct. It quickly became evident that in order for the full construction process to be completed, all the prep-work including site work and excavation, rebar cutting and bending, formwork cutting, and formwork assembly all had to be done prior to the team's arrival. This can be seen as the first black dot in the schedule (*Figure 13*). Finishing these tasks by August 9th allows the team to immediately start pouring the foundation upon their arrival, when the most hands will be needed.

After mapping out the two structural systems, there were two main takeaways. The first is that concrete columns are ultimately infeasible due to going over the allowed twelve work days. The concrete column system would need three more days (*Figure 13*) to finish the structural components alone and another two days to apply any finishes. An important factor that delayed the schedule was a two-pour system that was chosen for the purpose of minimizing waste as well as accommodating the size of the team. The two-pour system splits the highlighted slab area into 2 sections (*Figure 12*). This system would work by first pouring half of the concrete slab, waiting three days for it to cure, then simultaneously pouring the columns for the first slab as well as the second half of the slab. The time spent forming, pouring, and curing concrete ultimately pushed this structural system past the required end date.

The structural system consisting of built-up timber columns and steel bracing (*Figure 6*) enabled an optimal schedule (*Figure 14*). This schedule allows for reduced concrete curing time, reduced labor intensity, as well as a reduction in the amount of fabrication required. The result was that the structural scope of the project could be finished by August 20th, which falls within the allotted time for construction.



*Figure 13: Concrete Column and Steel Brace Schedule*

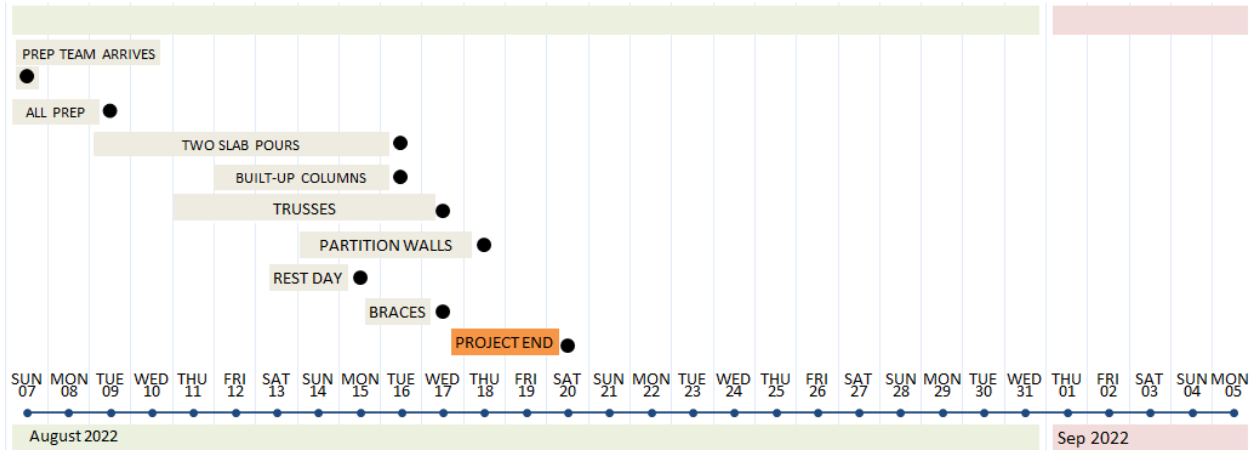


Figure 14: Timber Built-Up Columns and Steel Brace Schedule

The last component of the study was to create a cost estimate for each of the construction schedules. Although there are numerous components to determining the exact cost of a project, a few essential ones were selected for the estimate. The key aspects taken into consideration are the following:

- I. Materials & Delivery
  - A. Quantity
  - B. Availability
  - C. Ability to source locally
- II. Labor
  - A. Fabrication
  - B. Assembly
  - C. Erection
  - D. Technical skills required
- III. Tools
  - A. Availability
  - B. Work space
  - C. Operating type: power tools vs. hand tools

These estimates also help support the team's decision to move forward with built-up timber columns instead of concrete columns. The process of collecting unit costs for all the materials proved to be one of the bigger challenges. The local cost to source materials for the structure was provided by MISD based on previous trips to Same. Labor, delivery, and tool costs also came from prior invoices and receipts. A few of the items that required investigation were roofing material, gutters, connections, sheet metal, structural plate metal, and any other architectural finishes. In pricing these elements, the most current exchange rate between the U.S. dollar and the Tanzanian shilling was used to ensure accuracy. The exchange rate used was 2,300 TSh to 1 USD. In total, the built-up timber system was estimated to be \$1300 USD less expensive than the concrete system (about 6%), and generated less waste by eliminating concrete formwork. These savings are relatively minor, so the decision to pursue a wood-only structural system was made primarily based on the preferable schedule that system allows.

## Prototyping

Given that the design was incomplete when our team joined the project, the team had the freedom to make changes to the structural system. In order to make informed design decisions, the team decided to prototype key elements of the proposed structure. The goal of these prototypes was to determine the feasibility of constructing our designs using the means and methods that will be available in Tanzania. The time and labor required to complete the prototypes aided in the development of the construction schedule, and the resulting architectural finishes were evaluated for quality.

In deciding which material to use for the structural columns, the team set out to gain more information regarding the feasibility of concrete by constructing a full-scale mock-up concrete column. The primary goals of this mockup were to investigate constructability of the column and the reusability of the formwork. Planed 2 x 4's were used to create the formwork since dimensional lumber can be easily sourced in Tanzania, and it is a material robust enough to use for multiple pours. The first pour resulted in a column with significant consolidation issues (*Figure 15*) due to an improper concrete mix design and a lack of vibration. A second pour was completed with the intent of improving consolidation as well as testing the reusability of the formwork. The formwork was easily removed and held its integrity through both pours. Additionally, the board form finish of the concrete was consistent between pours, proving the formwork to be reusable. To improve the finish of the concrete, the second pour utilized a vibrator with a 10-foot trunk, and concrete mix with high water content. These changes yielded improved consolidation, but pockets and inconsistencies were still present throughout the column (*Figure 16*). Both pours took six students about three hours. The team concluded that although the formwork would be reusable, the poor architectural finish and large labor commitment made concrete a suboptimal building material for this application. After discussing our findings with MISD and gaining approval, our team moved forward with timber as the primary structural material.

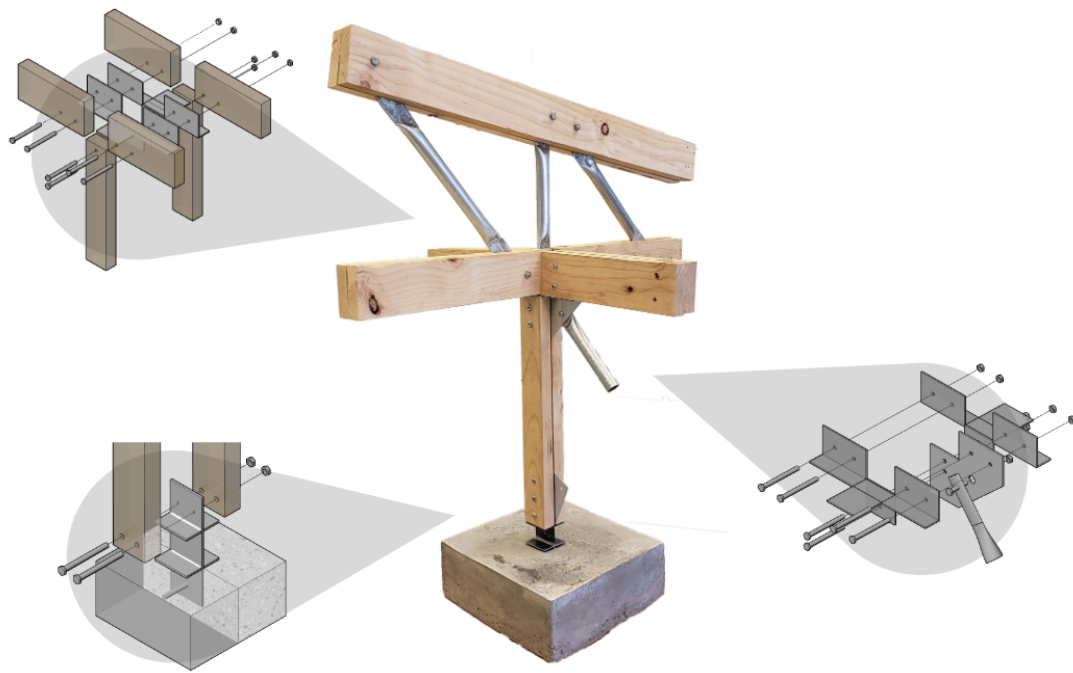


*Figure 15: First pour: two lifts, no vibration, low water content*



*Figure 16: Second pour: one lift, trunk vibrator, higher water content*

Once the team's focus shifted to timber members as the main structural material, the connection details were developed (*See Structural Detailing*). To test the constructability of these details, the team created a half-scale model utilizing all of the proposed connections (*Figure 17*). Similar to the concrete column prototype, the main goal was to test constructability using the limited means and methods that can be found in Same such as drills, circular saws, hammers, and vices. This model, dubbed the Tower of Power, successfully demonstrated that the connection details were both constructible and aesthetically pleasing, while making shortcomings of the design obvious. For example, many of the connection details have multiple bent or welded plates that must line up for bolts to go through, meaning the construction tolerances must be very accurate with slightly oversized holes in order to make sure everything lines up. Moving forward we know that we must create drawings for each connection that are carefully detailed to allow for ease of construction. Additionally, it is important for details to be clear enough for construction to continue seamlessly once the team has left Tanzania, since subsequent classroom modules will use the same details for connections.



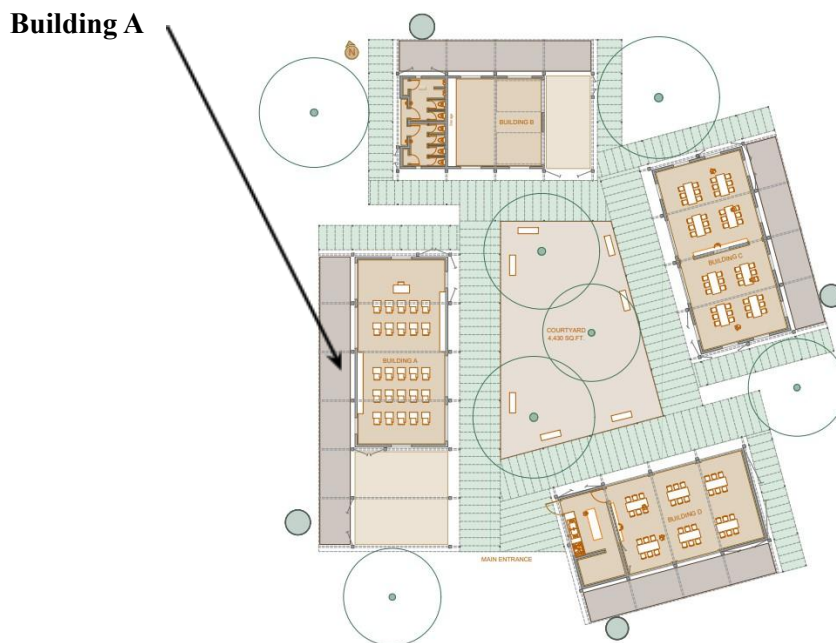
*Figure 17: 1/2-Scale Tower of Power model*

### **Design Documentation**

Initial iterations of connections were generalized in order to fit any material with some fine tuning. Plate, sheet metal, and bolts were the main pieces used in all details as the material would be readily available in Same and the connections would be kept similar and simple to construct. The team designed metal connections that could be either folded or welded, allowing for flexibility in construction and accommodating any change in supply that may arise in Same. A pinned column base connection was the basis for the design of all other member connections, to keep details consistent and following a structural motif of hidden connections.

Rather than create a set of construction documents that is the traditional American method of translating instructions of how to put together components of the building to the builders, the team decided to create a Means and Methods packet in order to communicate building methods through visuals with minimal text as a solution to overcome the language barrier and ensure consistency throughout the building process. The team attempted to create Ikea-like drawings to clearly convey these instructions in a sequential manner to make sure that when builders are on site, they could easily follow these steps and construct the connections with the resources they have available.

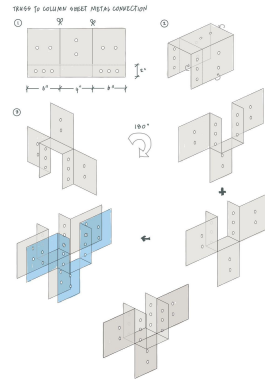
In order to begin the Phase 0 build in Same, the team organized a permit set which included plans for the building that will be constructed this Summer 2022. Within the college of construction, the main classroom, building A, is to be constructed (*Figure 18*). The plans included a foundation plan, floor plan, and sets of sections and elevations for this classroom. Unlike the standard set of structural drawings, these permit drawings combine the architectural elements of the design, including the foldable sisal partition walls and acoustic paneling, with the structural components, such as the timber posts and trusses. This mixture of disciplines reflects the manner in which the school was designed, in coordination with the interdisciplinary ARCH and ARCE team this year, as well as the various majors from prior years.



*Figure 18: Cluster Plan*

Throughout the design process, the team was intentional about keeping design components consistent through details for the brace to column connection, the base to column connection, and the truss to beam to column connection. In one of the previous iterations, the team created a cap detail that would work for both the base and the top of the column (*Figure 19*). One would hug the base of the column and be connected to a screw or piece of rebar that would be stuck into the concrete (inspired by the pin connection used in the Children's Village project located in Brazil), (*Figure 20*). The other one would hug

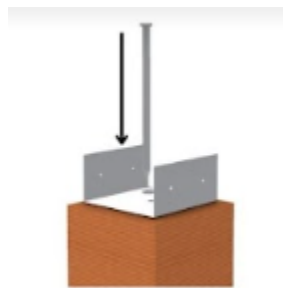
the base of the truss and then be connected to the top of the column and the beams while also taking into account the use of concrete versus wood columns by using screws/bolts or rebar that would potentially connect the truss to the column depending on what material the columns would be (*Figure 21*).



*Figure 19: Initial iteration of instructions for base to column and truss to column sheet metal connection*



*Figure 20: Initial iteration of the base to column connection*



*Figure 21: Initial iteration of the truss to column connection*

After looking into new precedents, we decided to attempt connections that would be hidden, this time accounting for a brace connection as well using only wood built up columns that would be using two 2x4 vertical planks attached together. As explained and shown in the Structural Detailing portion, the construction of these connections kept a consistent structural motif with the same concept at the base to column connection, as the top connection having the brace frame and “pin” metal connections slide in between the two planks and go down into the concrete (*Figures 7-10*). Although detailing of these



connections had changes made to its methods, the team was able to use previous iterations of formatting in order to continue to convey these instructions in a clear manner.

### **Impact**

When considering the architecture of this building, environmental factors were the driving force for the orientation of buildings. Sloping roofs allow for simple drainage and water collection, and open canopy structures make use of wind patterns in order to ventilate and cool the interior spaces. These decisions make it so there is very little environmental impact as a result of keeping the college operational and comfortable for occupants. Solar panels may later be implemented in order to provide electricity to the spaces, while keeping emissions low. In addition, when determining the type of materials that would be used, the team wanted to be sure that many of the materials that would be used for the construction of the school could be locally sourced, which will contribute to the local economy, especially if this project inspires similar developments in the country. Providing jobs during and after construction will not only support the local community, but will encourage residents to attend the college.

Although this project's intention is to provide a stepping stone for the community in Tanzania to have access to a better education, it also emphasized the importance of individuals in the building industry to be aware and sensitive of the environmental, political, social, and economic impacts of a project, as these are the building blocks for the design strategy at the beginning stages of projects.

As mentioned before, the correlation between the rates of school enrollment and its impact on poverty is very apparent in Tanzania. This project will provide a stepping stone for the community in Tanzania to have access to a better education, with the school including colleges that teach agriculture, construction, business, tourism, automotives, and education, in hopes that these future leaders can continue the education, advocate for their needs, and be able to implement necessary changes through having the opportunity to be able to go into a field of study that would provide them job security, learn about the social and political climate in their country and therefore being able advocate for their needs in their community.

### **Reflections**

Paulina Robles: This project was challenging and rewarding, as it provided me with the ability to rethink my methods of communicating designs. Being on the design documentation team meant taking a visual approach to details to solve the issue of a language barrier between the Cal Poly team and the people of Same. This project allowed me to focus heavily on the social, global and cultural impacts of my work, something we do not typically do in our day to day classes. Focusing on constructability was important, and working with the prototyping team allowed us to make changes to our work according to their testing and insights. In classes, we design using very industrial connections that are typically hidden beneath architectural finishes. This project however, was an exposed canopy structure, making it more important for us to consider aesthetics in our designs and pushing us to use hidden connections. Remaining flexible while materials and scheduling were still undecided was difficult at first, but allowed for us to brainstorm for longer on a library of previous iterations to work off of. Communicating among engineers and with

architects was important, as we each needed to check in with each other before going through with any large changes in the design.

Anna Yamauchi: As part of the construction document team, a large goal was to create details and instructions that could be understood universally regardless of your vernacular or familiarity of traditional documents. This exercise helped me think critically about the additional challenges of construction in a foreign and underdeveloped country. It was such a great experience to see a project into fruition and realize how all the elements must fit together. I enjoyed being part of a project that can have such a great impact, and it made me further appreciate and understand the intricacies of completing a project a foreign country. I now realize the complexity of a project on this scale, and how essential it is to understand the local culture and socio-economic behavior, while ensuring good communication between all parties. I hope these values stay central to the project as construction begins this summer.

Surina Marwaha: Working on this project with the big group of ARCH and ARCEs was such a valuable experience for me in learning how to change my mindset to allow for the various different ideas and viewpoints presented. Within the design of the school, the layout, materials, and essentially every portion of the project was constantly changing. So, learning to be flexible with these changes by embracing the process as it created new ideas, and organizing myself within the drawing process so that the drawings were easily adaptable, was a new challenge that made me appreciate the holistic nature of the project. As a part of the design documents team, it was vital for us to understand the local culture of Same, including the climate, social patterns, local building materials, and even traditional building strategies, so that we could incorporate those factors in our design as well as the construction drawings we presented. The most important mindset of this project for me was remembering that the local people in Same know how to build in the best way for their community, as they have been living and building there for their entire lives. We are simply providing resources, new designs and techniques for them to learn, but ultimately they can decide if they want them. Understanding this concept helped drive many of the details and construction methods we used, as it was essential to relate the two building practices in hope to integrate the Same Polytechnic College with the pre-existing community. I'm very grateful to the team for the exciting and collaborative nature this project had from research to final design.

Tia Kelly: Being a part of a project in an underdeveloped country emphasized the importance of understanding the local culture, environment, and traditional construction practices in creating a successful design. Utilizing local knowledge is essential to creating a space suited to the community's needs. Expanding upon the initial given design while maintaining the original concept was both difficult and rewarding. It was a new experience to have a well-developed concept with room for us to change or make decisions, unlike most projects I have worked on in school, which have been either entirely designed beforehand or not at all, with complete flexibility. Through these design constraints, along with the constructability constraints in Same, I have learned how to become a more flexible and resourceful engineer. Most importantly, I have learned that communication between all disciplines is paramount to a team creating a cohesive, successful design.

Dillon Schneider: There is a great benefit to having a significant part in the design of the structure while concurrently prototyping ideas and that is the exploration of constructability. Projects we work on as students through our design courses are highly technical and tend to be biased towards calculations and

some detailing with little practical application. The difference between a design laboratory and a project like the Same Polytechnic is that with this project we need to go beyond the scope of a structural engineer and even the building itself. Understanding local building techniques, available materials, and the school's purpose in the culture of Same is important to breathe life into a structure that will be fully integrated into a society were all some of the learning opportunities of this project. Focusing back in on the structure, one of my favorite learning opportunities was the simultaneous development of the architectural system, the prototypes, and the connection details. This was a learning opportunity because of the need to be adaptable with our designs in that they will need to have a consistent functionality while things like material and dimensionality are constantly changing. We learned to present our ideas quickly and efficiently while making minor adjustments to account for design changes and realizations and later prototype scale mockups of connections very easily because of our well-rounded understanding of each connection. Beginning a project with research and studying previous work and leading into an interdisciplinary design model is a great representation of what many of us will do when we start working and this opportunity has prepared us well for some of the challenges we will face.

Audrey Hoang: This project allowed me to fully appreciate the importance of understanding the cultural, political climate, and socio-economic statuses of the region the team would be designing the school in. As structural engineers, it is important to go outside our comfort zone of only having a technical understanding and also do research on and interact with the community to ensure that we are not overstepping any boundaries while being able to contribute to a positive impact on their community and incorporate their culture and ideologies into our efforts. Working with the design documentation team allowed me to visualize traditional construction documents in a different light, as the team instead created a means and methods packet to convey instructions through visuals. Not only did I gain a stronger technical understanding of how components of a building are put together, but also I have a greater appreciation of efforts made to make construction documents as easy to follow as possible and the importance of communication, as everyone has something to contribute in their own unique ways. Being able to work on the Same Polytechnic College clarified to me what it takes to work on a project like this one through our teams that included prototyping, design documents, and cost and scheduling. I'm extremely grateful to have had the opportunity to work on this project and learn more about the region, and I hope that Cal Poly students can continue this construction on the other parts of the college and continue to grow their connection to the community in Tanzania.

Connor Gilligan: Throughout this project, I learned many things about the design-build process. One essential aspect I learned, especially with many people being a part of this project, was the importance of communication and coordination. Throughout our work, as someone came up with a new idea or edited an old one to make it more constructible or structurally sufficient, these new changes needed to be communicated to the group. Otherwise, people would continue to work on deliverables for an old and now obsolete design. This project also provided some unique conditions that I have not come across in school or work due to the fact that it is being built in Tanzania. This meant that not only did we want to make sure the structure would be safe and look good architecturally, but we also had to focus a lot of effort on constructibility. Making small paper models and drawing things out helped us work through initial problems we may come across when building. However, the best way to test the constructibility was to make full or half scale models using similar materials, tools, and other methods that we would utilize in Tanzania. Overall, the intended impact of this structure made this project very fulfilling as we

will enlist local artisans to help with architectural aspects, builders to help with the construction, and ultimately, once the school is complete, provide jobs and specialized education for the people of Same.

Jennifer Viveros: I learned several valuable construction and engineering aspects through the course of this two quarter project. Among them, my main take-aways are the intricacies of a construction schedule, the importance of active communication in a large team, and the constructability of details within a structure. The first was learned simply through the creation of the two construction schedules for the project. Not only did I plan out the construction process for a complete modular unit for the college, I reorganized it for a different structural system. I had to be very flexible and patient while our team moved forwards with narrowing down on the choice for structural materials. This means that the schedule was constantly being altered, adapted, and updated throughout the project. Even at our end, it has some room for updating and revamping. Secondly, active communication was probably the key player throughout the entirety of the project. There were moments where our team excelled in communication skills and there were moments where we faltered. Overall, our success came from the times where we all clearly vocalized out goals, intentions, and delegated responsibilities efficiently. Lastly, the design of the connections throughout the structure was a major learning curve for me. I worked closely with the detail team to collaboratively decide what connections were efficient in constructability and which posed challenges. This process was something that has been talked about in several ARCE classes but had never been done on our own. Since this project was ultimately designed to be built in just a few months, the feasibility and constructability of our designs was arguably the most important aspect of the structure. I am so glad to have been able to work with so many talented individuals and be a part of creating something meaningful.

Jenna Beutelschies: I loved the challenge of designing a project with constructability at the forefront. We had much more limited resources than with past projects in the classroom, so we needed to get creative with how the structures would be built. This was especially a concern since I was in the scheduling and cost group. We had to figure out which items could be assembled separately and erected later, such as the trusses. Pouring a concrete column with the prototyping group was also useful to understand how long a process like that would take on site. I had done some scheduling in my past construction management classes, but this experience really took it to the next level. I also enjoyed learning about the country of Tanzania and how this project will benefit their community. I had previously gone on some service trips to Belize, another third-world country, and helped with the construction of a concrete and masonry school, so getting to apply my architectural engineering curriculum to a similar project these past few quarters was very rewarding. This project taught me a lot about the importance of communication, especially with the architects. Everyone involved had a unique perspective and ideas that we needed to consider. It is difficult when us engineers have a goal revolving around constructability and satisfying code requirements, whereas the architects care more about the aesthetics and circulation. We had to compromise a bit to make everyone happy, but overall I think everyone is satisfied with the outcome and what we were able to create by working as a team.

Robert Hardwick: To say this structure is technically difficult is to sell short all the design experience I have gained in the Cal Poly ARCE program. However, that's not to say that designing the first installment of the Same Polytechnic College was simple — the process came with more challenges than I could have ever envisioned at the outset of the project. The structure has negligible seismic force, is practically

weightless, and has little area for wind to blow on, which made designing members simple, almost unnecessary. Designing a structure that could stand completed on the site in Same within the next 3 months? That's where the difficulty of this project lay. The pros and cons of every decision had to be weighed, compromises had to be made, all in the pursuit of an optimal design.

In realizing that there are very few known quantities in design, I gained confidence in my own engineering and aesthetic judgment. In working as a member of a large team, I developed an appreciation for proper division of labor, and I focused on how my individual contribution could add value to the work of the group. Through my work on the prototyping team, I learned that proving the viability of an idea to yourself and others sometimes requires actually following through with that idea, for better or for worse. I see now from a holistic viewpoint that my work on proving the difficulty of using cantilevered concrete columns was productive, and that the care I put into doing it correctly was not misplaced. My task was to create knowns from the sea of unknowns, which drove the design process toward the end product more quickly, and with more confidence.

Finally, I gained insight into the process of turning a nebulous idea into a constructible building. Coordination between disciplines — just like in the real world — wasn't always easy, but the final design benefitted from frequent collaboration. I am glad I took on the Same Polytechnic College as my senior project because it aligned so well with my engineering and service interests, and pushed me to be a better engineer and a bigger thinker.