

# About the Validation of Advanced Membrane Process Control Systems in Wastewater Treatment Applications

Marco Stoller

Department of Chemical Materials Environmental Engineering, 'La Sapienza' University of Rome, Rome, Italy  
[marco.stoller@uniroma1.it](mailto:marco.stoller@uniroma1.it)

This paper focuses on the validation of advanced control systems to use on either batch or continuous, new or existing membrane process plants, by use of a simulation software (Aspen Hysys).

In the last decade, membrane technologies resulted to be very appealing and shows positive market trends. One main drawback is membrane fouling, which affects productivity, selectivity and longevity of the process, which leads to both technical and economical failures: proper membrane process design and control is a difficult task to accomplish. This leads to overdesign the plant capacities by process engineers, making this technology less reliable and convenient.

Nowadays membrane processes are controlled by a constant permeate flow rate or constant applied operating pressure. These simple control strategy approaches are sufficient to operate the processes, but do not distinguish different fouling operating regions, and therefore do not avoid process failures due to fouling.

Fouling may be described by the boundary flux theory in a convenient way, separating low-fouling operations from high-fouling ones.

The paper reports about the validation of an previously developed advanced membrane process control system based on the boundary flux concept on different wastewater feedstocks. The advanced control strategy by the use of a simulation software by Aspen Hysys, capable to predict boundary flux values by measurement of some key parameters, was validated and capable to set suitable set-point values to the feedback controllers in order to work at or below the boundary flux. As a consequence, the membrane process is always operated far from irreversible fouling issues. The developed approach was then successfully validated by experiments on lab scale.

## 1. Introduction

Membrane separation technologies have acquired a great importance in the sector of water and in particular wastewater treatment due to its wide range of possible application, ease to scale-up and great versatility. Membrane processes combines high productivity and high selectivity towards pollutants, and therefore high efficiencies capable to treat environmental hazardous effluents to purified water, reaching the requirements for a reuse. Nowadays, about 60 million m<sup>3</sup> of wastewater are treated every day, and almost 50% by microfiltration (MF), ultrafiltration (UF), nanofiltration (NF) and reverse osmosis (RO) processes. In the next 10 years, an annual growth of 10% of the capacity of wastewater reuse processes is foreseen, and most probably membrane technology will gain in importance.

The main drawback of membranes appears to be membrane fouling, that requires to be avoided or at least inhibited since it does not permit to assure the performances over a long period of time once it starts to form. Much research and expertise is focused on membrane fouling, and covers modelling (Jerez et al., 2008), reporting (Dauphin et al., 2001), development of new membrane materials (LU et al., 2002), suggestion of proper operating conditions (Stoller et al., 2013), management and control of the process (Astrom and Hagglund, 1995), proper pretreatment processes (Stoller et al., 2014) and cleaning procedures (Stoller, 2013). The result of the actual know-how is that fouling cannot be avoided and exists to different extend in every membrane system. If the fouling formation is neglectable, it might not be considered when compared to other phenomena such as aging. On contrary, is sensible fouling occurs, the phenomena represent the bottle neck to overcome to guarantee a reliable membrane process.

The latter case is, in case of wastewater treatment, the most common one. In this case, for a given system, options to inhibit fouling are

- modelling and suggestion of proper operating conditions: the boundary flux concept and determination seems to be the best method to identify process conditions in order to limit the formation of irreversible fouling. At the boundary flux point the drag forces on the particles depositing on the membrane surface are equal to the dispersion forces, leading to a reversible, quasi-stationary layer. Under these conditions, only reversible fouling, which can be periodically soft-cleaned, takes place. This ensures long membrane life times.
- proper pretreatment processes: since operation is limited by the boundary flux it is important to increase sensibly its value. This can be performed by proper pretreatment of the feedstream (pretreatment tailoring).
- management and control of the process: once the boundary flux value is determined and the changes as a function of time are defined, a control system should be implemented in order to operate correctly the system. Recently, advanced control systems for membrane processes based on the boundary flux concept were introduced in the framework of membrane technology and requires more development and validation work.

This work deals with the validation of an advanced control system based on the concept of the boundary flux of a UF and NF membrane plant used to purify olive mill wastewater streams (OMW). In first step, the measurement of the boundary flux was experimentally performed and the collected data was used for the model. After this, a computational simulation using Aspen Hysys V8.0 simulator (Aspen Tech) was developed for this process. This passage has required the additional programming of a customized membrane unit, which allowed the integration of the advanced control system based on the boundary flow concept. Finally, the approach was validated by dynamic simulations.

## 2. Methods

The methods used for this work were similar to those suggested by other researchers, in particular Espinasse et al. (2002) and Field and Pearce (2011), that developed to the boundary flux measurement and determination by Stoller and Pulido (2014). On the basis of preliminary results, Stoller (2015) reported the possibility to develop advanced control system logics based on the boundary flux concept.

Several models based on physical concepts were presented to describe the operation of membrane separation starting from a solution. The model of film theory, polarization for concentration, osmotic pressure are some examples. The choice of a proper model is key for the reliable development of a good control system. In the state case of this work, the presence of sensible fouling leads to complex design and is not always considered by simple models. Therefore, the implementation of the boundary flux concept appears to be mandatory.

Stoller and Pulido (2015) have developed this model based on the theory of the critical flux and threshold flux proposed by Field and Pearce (2011). The permeate flow is a function of the transmembrane pressure and the permeability of the membrane, that is:

$$J = m \text{ TMP} \quad (1)$$

Introducing the boundary flux  $J_b$ , the equations can be generalized as:

$$\frac{dm}{dt} = -\alpha \quad Jp(t) \leq J_b \quad (2)$$

$$\frac{dm}{dt} = -\alpha - \beta (Jp(t) - J_b) \quad Jp(t) > J_b \quad (3)$$

where:

-  $\alpha$ , expressed in [ $L \text{ h}^{-2} \text{ m}^{-2} \text{ bar}^{-1}$ ], represents the constant permeability reduction rate suffered by the system and will be hereafter called the sub-boundary fouling rate index.

-  $\beta$ , expressed in [ $\text{h}^{-1} \text{ bar}^{-1}$ ], represents the fouling behavior in the exponential fouling regime of the system and will be hereafter called super-boundary fouling index.

The boundary flux values depends on many parameters, such as hydrodynamics, temperature and membrane properties. These latter parameters may be controlled by simple feedback controllers with ease. The most interesting parameters concerning a successful implementation of the relevant equations in an advanced control system logic are therefore two: feedstock characteristics and time. Stoller and Pulido (2015) have introduced a relationship of the boundary flux value as a function of a key parameter of the feed, able to fully characterize the stream in terms of chemical properties, and time. The final equation is as follows:

$$J_b(KP, t) = w P_b - \alpha t P_b - (w \rho_1 - \alpha \rho_1 t + m_1 P_b) * KP + w \rho_1 KP^2 \quad (4)$$

where:

- $w$ , expressed in [ $L h^{-1} m^{-2} bar^{-1}$ ], represents the pure water permeability.
- $P_b$ , expressed in [bar], represents the boundary operating pressure.
- $\rho_1$ , expressed in [ $bar L mg^{-1}$ ], represents the fitting parameter of the osmotic pressure.
- $m_1$ , expressed in [ $L^2 h^{-1} m^{-2} bar^{-1} mg^{-1}$ ], represents the fitting parameter of the membrane permeability.
- $KP$ , expressed in [ $mg L^{-1}$ ], represents the feedstock chemical analysis.

Eq.4 requires the input of several parameters. By a pressure cycling test, which consist in keep constant the pressure value for a time  $t_2-t_1$  and measure the decrease in the permeate flow through time, it is possible to determine values of  $J_b$  for different (known)  $KP$  values. Moreover, following relationship holds:

$$-\alpha = \frac{J_{p_{in}} - J_{p_{fin}}}{TMP(t_2 - t_1)} \quad (5)$$

$$\beta = \zeta(TMP_b - TMP)^\varepsilon \quad (6)$$

being  $\zeta$  and  $\varepsilon$  fitting parameters that are determined by experimental work.

If the transmembrane pressure is kept constant during a time  $t_2-t_1$  under sub-boundary conditions, the permeate flow undergoes a linear decrease in that time:

$$\int_{J_{p_{in}}}^{J_{p_{fin}}} dJ = -\alpha TMP \int_{t_1}^{t_2} dt \quad (7)$$

$$J_{p_{in}} = J_{p_{fin}} + \alpha TMP(t_2 - t_1) \quad (8)$$

On the contrary, in super-boundary conditions the membrane permeability does not decrease with constant rate (equation 3) and the permeate flow undergoes a drop nonlinear, but exponential through time:

$$\int_{J_{p_{in}}}^{J_{p_{fin}}} \frac{dJ}{-\alpha - \beta J + \beta J_b} = TMP \int_{t_1}^{t_2} dt \quad (9)$$

$$J_{p_{in}} = J_{p_{fin}} + \frac{\alpha + \beta J_{p_{in}} - \beta J_b}{\beta} (e^{-\beta TMP(t_2-t_1)} - 1) \quad (10)$$

where,  $J_{p_{in}}$  and  $J_{p_{fin}}$  are the start and end values of the permeate flow.

The set of eq. 1-10 were completed and used as the model equations for the developed adaptive control system by the following additional relationships:

$$m = w - m_1 KP \quad (11)$$

$$p = \rho_1 KP \quad (12)$$

$$R(KP) = \sigma [(TMP / (TMP+\theta))] \quad (13)$$

where  $\sigma$  and  $\theta$  are fitting parameters.

### 3. Experimental

As the reference system for this work, a UF and NF process for the purification of olive mill wastewater streams was used. The samples were obtained from an olive mill situated in Latina, Italy. OMW represents an environmental hazard due to the high quantity of organic and inorganic pollutant it contains. The most important organic components are: phenolic compounds, some organic acids and sugars. The wastewater stream was processed in series by coagulation with nitric acid, photocatalysis, UF and NF. Details of the adopted single processes are reported elsewhere (Stoller, 2013). Table 1 summarizes the obtained results in terms of purification of the waste water stream on a key parameter (COD) as well as in terms of boundary fluxes.

*Table 1: Summary of the obtained results from the experimental work*

| Stream                | $J_b$ [ $l/hm^2$ ] | $\alpha$ [ $l/h^2m^2bar$ ] | COD [g/l] | $\Delta COD$ total |
|-----------------------|--------------------|----------------------------|-----------|--------------------|
| Raw OMW               | -                  | -                          | 43.0      | -                  |
| UF feed               | -                  | -                          | 24.2      | 43.7%              |
| UF permeate / NF feed | 4.9                | 0.0033                     | 17.4      | 59.5%              |
| NF permeate           | 31.2               | 0.0012                     | 7.2       | 83.2%              |

### 4. Results and Discussion

The obtained data from the experimental work were given to the simulation code on Aspen Hysys. The membrane plant was designed by using three main sections: a feed and pressurization section, that includes a tank (T-01) with a capacity of 300 liters, which can be served by a multistage centrifugal pump (CPM); a filtration section equipped with a housing (Membrane) that contains the membrane module which is interchangeable and can be fitted with different types of membranes for studying various processes and a

thermoregulation section formed by a cooler (E-100) that allows to maintain the temperature of the feedstock in the tank (T-01). Some auxiliary equipment for the production and distribution of utilities (electricity and water coolant) and the pre-treatment of OMW completes the adopted scheme.

The first step was to define the thermodynamic model and the streams of the process, adding as the principal fluid of "water" and as a second stream the "organics", the latter one with properties similar to water. By this way it was possible to specify a COD value within the simulation framework. Both streams were defined using the UNICUAC-ideal package available within Aspen Hysys. The second step was to build up the simulation in steady state conditions. The software has some libraries of predefined components that includes the phenomenological set of equations. The user has to define as an input a certain number of data which allows the simulation code to calculate the operation of each element. For the design of the membrane (F-01) the UNITOPS logical spreadsheet was adopted and customized. The mathematical model used in the spreadsheet was that of the boundary flux (eq. 1-13). Membrane area and fitting parameters concerning selectivity, osmotic pressure and membrane permeability, as well as operating boundary pressure, the sub-boundary fouling rate index, pure water permeability, initial value(s) of the key parameter(s) and initial feedstock volume were all provided. HYSYS integrates all relevant model equations in time by using the integrated event schedule module. The final implementation appears in Hysys as shown in Figure 1.

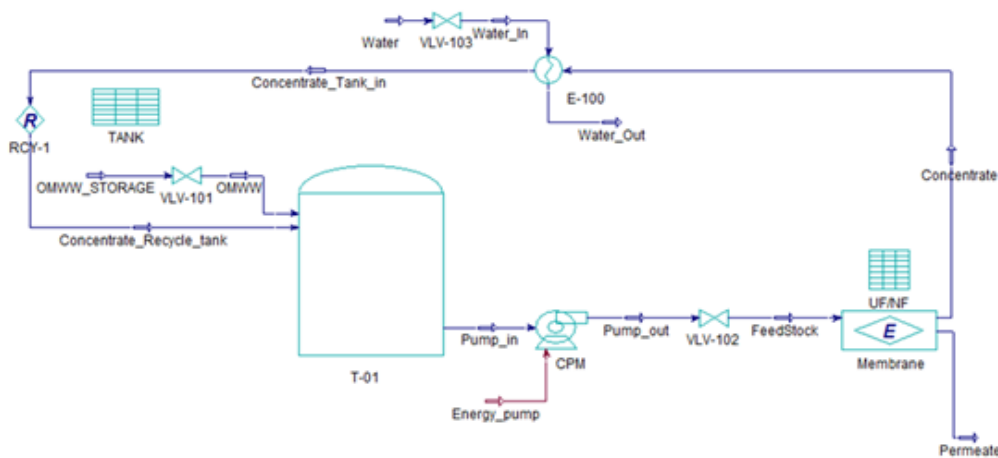

Figure 1: The implementation of the membrane process in Hysys.

After this, controllers were added to the scheme. The advanced control system on the membrane (FC-101) is of adaptive type. The control system relies on a feedback controller, but the suggested set-point values as a function of time were given by a model outside the controller itself. In this work, the model is integrated in the customized membrane unit, which calculates the boundary flux values and defines suitable set-point values based on eq.4 to the adopted PI controller. The controller follows these indications which are limited by a override by the maximum allowable pressure as a constraint towards security and safety (Astrom and Hagglund, 1995). In Table 2, all defined controllers are reported. Figure 2 shows the implementation of the FC-101 controller in Hysys.

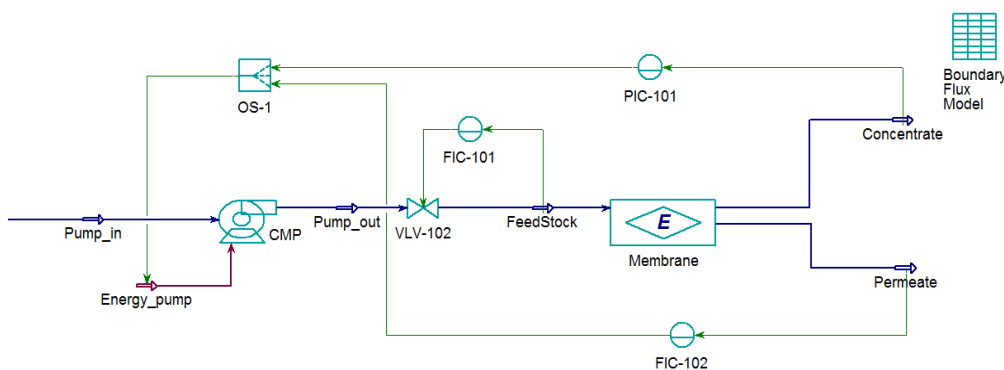

Figure 2: Implementation of the FC-101 controller in Hysys.

Table 3: Set-up of the controllers in Hysys

| Id     | Process variable | Manipulated variable | Set Point | Disturbances       |
|--------|------------------|----------------------|-----------|--------------------|
| FC-101 | Permeate Flux    | Energy pump          | MODEL     | Fouling            |
| FC-102 | Feedstock Flux   | VLV-102              | 600 Kg/h  | Operating pressure |
| TC-101 | Temperature      | VLV-103              | 15 °C     | Feed temperature   |

Concerning the membrane process, the constancy of the permeate stream (FC-101) at the set-point value given by the model calculations is assured by changes to the energy given to the pump (CPM). In order to determine the set-point value, the use of the model in dynamic mode is of trial and error approaches that the code performs automatically. The software checks at different permeate flux set-point values the evolution of the separation process as a function of the initial conditions and membrane fouling, choosing as the permeate flow rate set-point value the highest one that always results to be lower than the boundary flux values as a function of time and KP during the whole period of operation. A typical output of this analysis is shown in Figure 3. In the case of this work, the optimal permeate flow rate set-point value resulted to be 22.3 l/h (8.9 L/hm<sup>2</sup>).

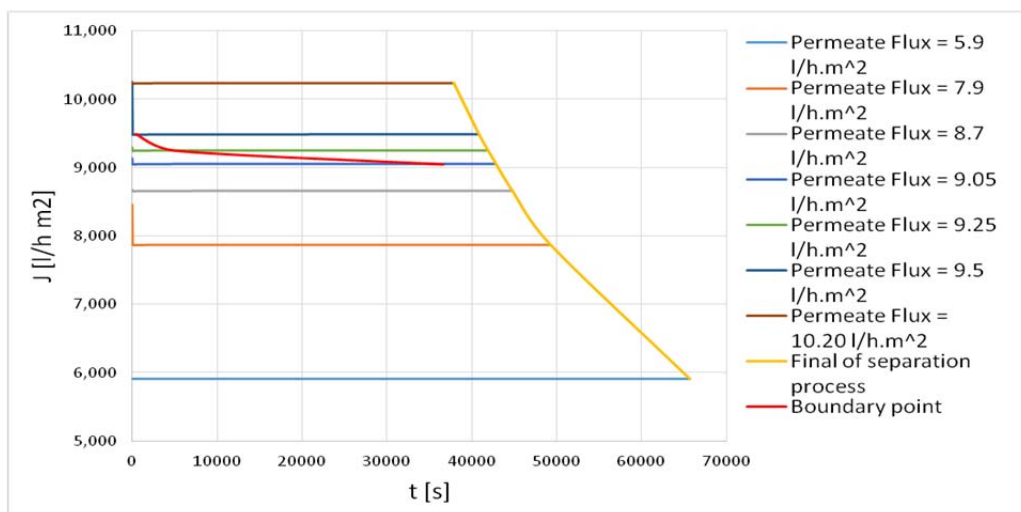

Figure 3: Output of the model implemented in Hysys

Once the optimal set-point was determined, the dynamic mode was used to simulate the process. In Figure 4 the plot of the manipulated variable (Energy pump) is reported, and it can be noticed that it fluctuates according to adjustments to perform on the controlled process variable. Throughout the operation the logic of the adaptive controller is not set to off, but capable to follow the separation, compare it with the calculated one, and in case to react by setting the set-point values again in case of necessity.

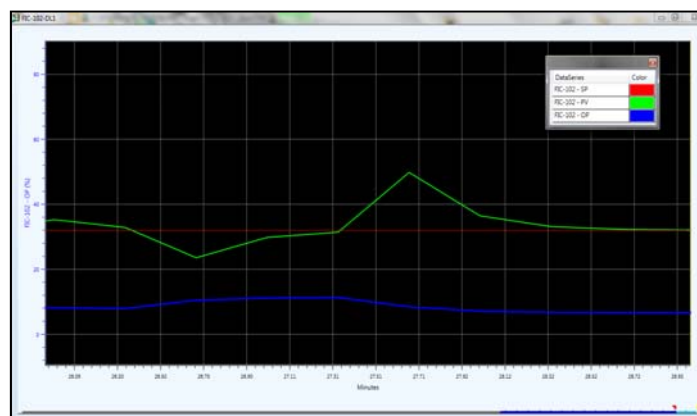

Figure 4: Output of the simulated membrane process controlled by FC-101.

## 5. Conclusions

The need of advanced control system to inhibit fouling issues on membrane processes may grow in interest in the next years, in particular for waste water treatment plants in order to avoid unneeded overdesign and premature technical failures, and as a consequence, high operating costs. An adaptive control system based on the concept of the boundary flux appears to be a reliable solution to this need.

The control system was developed under Hysys and preliminary simulation runs exhibit a good accordance between experimental and simulated data. Initial difficulty is encountered to provide proper input parameters to the model that can be determined by experimental work. After this, the control system is initialized and can be used to properly estimate the evolution of the operation, and as a consequence, it provides a helpful tool to avoid irreversible fouling conditions by the determination of suitable set-point values to the PI feedback control system connected to the permeate flow rate of the process.

## Acknowledgments

The contribution of Eng. Rosmery Serrão Mendes during her master degree work at Sapienza University under the supervision of Prof. Marco Stoller is gratefully acknowledged.

## References

- Astrom K.J., Hagglund T., 1995, "PID Controllers: Theory, Design, and Tuning", ISA, US, ISBN: 1556175167
- Daufin G., Escudier J.P., Carrere H., Berot S., Fillaudeau L., Decloux M., 2001, Recent and emerging applications of membrane processes in the food and dairy industry, *Trans IChemE* 79, pp 89–102.
- Espinasse B., Bacchin P., Aimar P., 2002, On an experimental method to measure critical flux in ultrafiltration, *Desalination* 146/1–3, pp. 91–96.
- Field R.W., Pearce K., 2011, Critical, sustainable and threshold fluxes for membrane filtration with water industry applications, *Advances in Colloid and Interface Science* 164/1-2, pp. 38–44.
- Jerez M.J.O., Velez Pasos C.A., Mejia E.F., 2008, Mathematical models of membrane fouling in crossflow microfiltration. *Revista Ingeniera e Investigación* 28/1, pp 123–132.
- Lu X., Bian X., Shi L., 2002, Preparation and characterization of NF composite membrane, *Journal of Membrane Science* 210 (1), pp 3-11.
- Schroetter J., Boskaya-Schroetter B., 2010, Current and emerging processes for water treatment, *Membranes for Water Treatment*, Wiley-VCH, 53-91.
- Stoller M., Ochando Pulido J.M., 2015, *The Boundary Flux Handbook: A Comprehensive Database of Critical and Threshold Flux Values for Membrane Practitioners*. Elsevier.
- Stoller M., Chianese A., 2007, Influence of the Adopted Pretreatment Process on the Critical Flux Value of Batch Membrane Processes, *Ind. Eng. Chem. Res.* 46 (8), pp 2249–2253.
- Stoller M., Ochando-Pulido J.M., Chianese, A., 2013, Comparison of critical and threshold fluxes on ultrafiltration and nanofiltration by treating 2-phase or 3-phase olive mill wastewater, *Chemical Engineering Transactions*, 32, 397-402.
- Stoller M., 2013, A three year long experience of effective fouling inhibition by threshold flux based optimization methods on a nf membrane module for olive mill wastewater treatment, *Chemical Engineering Transactions*, 32, 37-42.
- Stoller M., Ochando-Pulido J.M., Di Palma L., 2014, On the relationship between suspended solids of different size, the observed boundary flux and rejection values for membranes treating a civil wastewater stream, *Membranes*, 4 (3), 414-423.
- Stoller M., Ochando-Pulido J.M., 2014, About merging threshold and critical flux concepts into a single one: The boundary flux, *The Scientific World Journal*, Article ID: 656101.
- Stoller M., 2015, About the Development of Advanced Membrane Process Control Systems, *Chemical Engineering Transactions* 42.