



Evaluation methods for improving surface geometry of concrete floors: A case study



Giuseppe Loprencipe, Giuseppe Cantisani*

Sapienza University of Rome, via Eudossiana 18, 00184, Rome, Italy,

ARTICLE INFO

Article history:

Received 7 May 2015

Received in revised form 12 June 2015

Accepted 18 June 2015

Available online 28 June 2015

Keywords:

Industrial floors

Surface properties

Flatness and levelness

Profilometer

Evaluation

Surface treatments

ABSTRACT

Among various construction activities, related to concrete pavement technologies, an important role is reserved to industrial floors. For these structures it is necessary to ensure resistance and stability, durability, reliability, and many other properties. In particular, the flatness and the levelness are special requirements that assume a real significance respect to functional performances, especially when the pavement has to allow the movement of vehicles and goods or the storage in elevated stacks or shelves. These geometric properties can be defined in different ways, but in every cases they are referred to pavement surface, that has to be even (without superelevated or depressed areas) and level (horizontal, without grades, curvatures, and waves). The acceptance limits are defined by technical standards, in various countries, together with the suitable methods for measurements and controls. In many cases, however, these methods are considered not really feasible or easy, in particular when a continuous sampling of the pavement, along selected alignments, is needed. In particular, the paper describes the operating procedures to calculate indexes F_F and F_L , according to ASTM 1155M standard, starting from data provided by a contact profilometer. If the target values are not reach, it is necessary to provide some alternative solutions to avoid the demolition of the slabs or the payment of penalties by the builder, if this is required by the contract. There are two main possible methods for increasing flatness and levelness while other functional surface properties are maintained at the expected levels: the surface grinding and the overtopping with self-levelling and high resistance resins. A case study where the two alternative methods are applied to improve flatness and levelness of a surface is presented. The results of measures made before and after the treatments showed that both the solutions are able to ensure, within certain limits, the fulfillment of the requirements and consequently they can be used for the proposed aims.

© 2015 The Authors. Published by Elsevier Ltd. This is an open access article under the CC BY-NC-ND license (<http://creativecommons.org/licenses/by-nc-nd/4.0/>).

1. Introduction

Functional performances, for some kinds of concrete pavements, have the same importance of the mechanical properties that determine structural design. This happens, in particular, when it is necessary to ensure strict operating requirements due to particular exercise conditions. For example, the floors of warehouse or logistic centers, often present severe requirements for the surfaces regularity, not only with reference to the loads for goods storage but also in order to ensure safety and precision for handling of working vehicles.

* Fax: +39 06 44585121.

E-mail address: giuseppe.loprencipe@uniroma1.it (G. Cantisani).

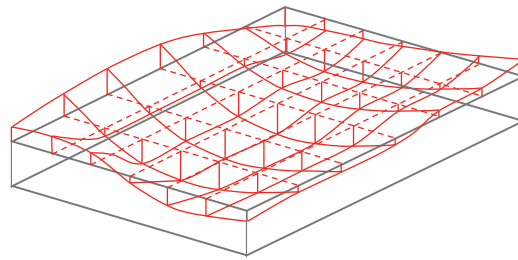

Fig. 1. Surfaces profiles for pavements regularity evaluation.

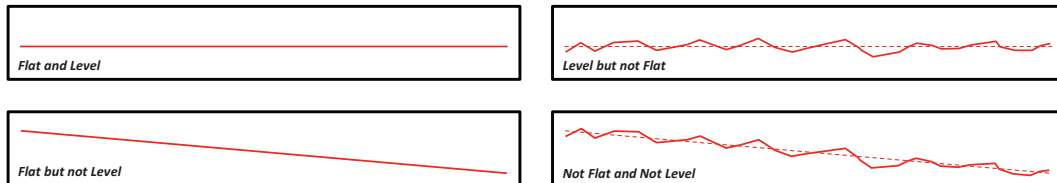

Fig. 2. Various kinds of irregularities can occur in the real surface geometry of a pavement.

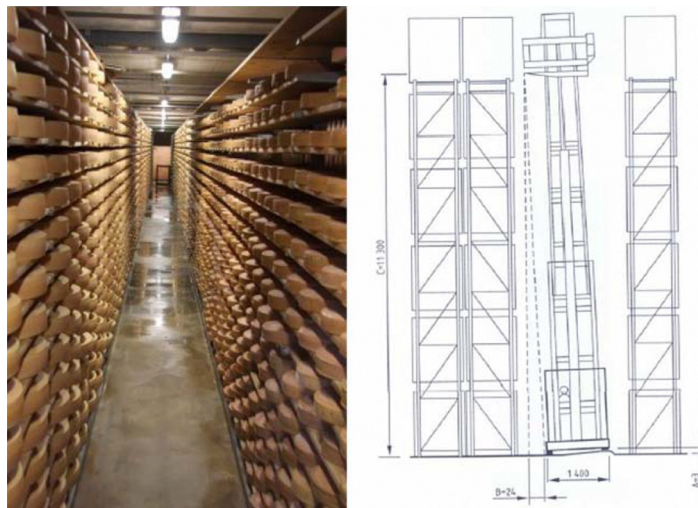

Fig. 3. The levelness of industrial floor can influence the height storage capacity.

Pavement regularity is normally defined by means of the evaluation of the differences between the points' elevation on the real surface with respect to an ideal reference plan. To allow simple measurement processes for this characteristic, it is easy to refer to some linear alignments (surfaces profiles), as showed in Fig. 1.

Surface regularity needs to be defined and controlled with regard to two features [1,2]. The first characteristic is called “levelness” and it evaluates the surface regularity over a longer distance, typically equal or more than 3 m. The second characteristic is defined “flatness” and it evaluates the surface regularity over a short distance, typically equal to 300 mm.

In Fig. 2, different cases of surface profile irregularities, in comparison to an ideal flat and level profile, are shown.

Good levels of flatness and levelness should be guaranteed for an industrial cement surface floor, for several reasons, depending on the operations performed in the warehouse. In particular:

- the *flatness* affects handling of vehicles on the areas, because it causes problems on their maneuverability and safety in consequence to dynamic action induced on the vehicle during the running on the unevenness surface;
- the *levelness* influences the height storage capacity of goods: Fig. 3 shows a static equipment storage and how the variation in floor level across an aisle between the supports is magnified at the top of the mast, proportionally to its height. Variations in level also induce dynamic movements in the mast that can magnify the equipment by factors as great as from 3 to 4.

Regarding the handling areas in a warehouse, in general two different types of zones need attention (Fig. 4): areas of free-movement traffic and areas of defined-movement traffic:

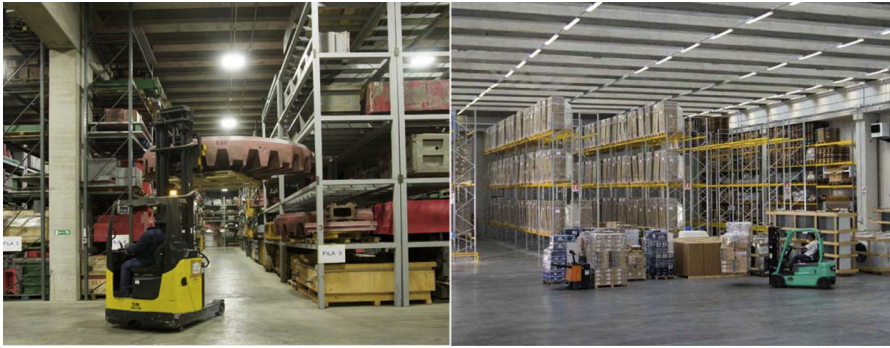

Fig. 4. The flatness of industrial floor can influence the handling of vehicles.

- in *free-movement areas*, vehicle can travel randomly in any direction and have an infinite number of travel paths;
- in *defined-movement areas*, vehicles use only fixed paths in very narrow aisles.

Distribution and warehouse facilities often combine areas of free movement for low-level activities such as unloading and packing alongside areas of defined movement for high level storage.

The two uses of floors require different surface regularity specifications so that appropriate performance of the floor can be achieved.

The pavements, in general, can present various levels of irregularity on their surfaces, depending on different factors and, in particular, because of:

- general characteristics of the pavement (size of slabs, joints, subgrade, etc.);
- constructional methods (working equipment, paving and finishing techniques, etc.);
- cement characteristics (consistency of the mixture, evolution of hardening, distribution in the layer, concrete homogeneity and fluidity, bleeding, aggregates sinkability, stickiness of the concrete, non-homogeneous hardening, etc.);
- external conditions (temperature and humidity of environment, ventilation, discontinuity of the paving process, experience of operators, etc.).

In order to improve the regularity of slabs surfaces, it is possible to take different action on one or more factors during the construction phase, but sometimes that is not enough and the required limits could not be reached.

Referring to the following sections for further details concerning the measurement methods, assessment and reference standards, it should be noted that there are some actions that can improve the conditions of flatness and levelness of a floor. In particular, they are:

- surface grinding;
- use of self-levelling and high resistance resins.

In this paper, the results of some measurements and data analysis – carried out on industrial floors and with reference to the indexes provided by technical standards for flatness and levelness characterization – are presented. The measurements were performed on surfaces that did not reach the prescribed limits and, for this reason, they were treated with the two above indicated methods. The results obtained show the range of variability of the parameters which characterize flatness and levelness, and allow to highlight the importance of a statistical treatment of measured data, according to the standard for the pavements functional properties evaluation.

2. Methods for measurements

In order to evaluate the state of paved surfaces, with reference to the above listed characteristics, various conventional measurement methods were proposed in the past, and some of those are still used. They are generally based on some fixed length straightedges (Fig. 5) that allow to perform, quickly but discontinuously along the surface of the pavement, the measurements on geometrical irregularities; consequently, it is possible to obtain the evaluation of geometry of surfaces and to judge if they fit to some established requirements.

The methods based on discontinuous measures, however, over the years showed some methodological deficiencies that encouraged the technicians, operating in this field, in developing alternatives for measurement and evaluation procedures. The main inadequacies of straightedges are:

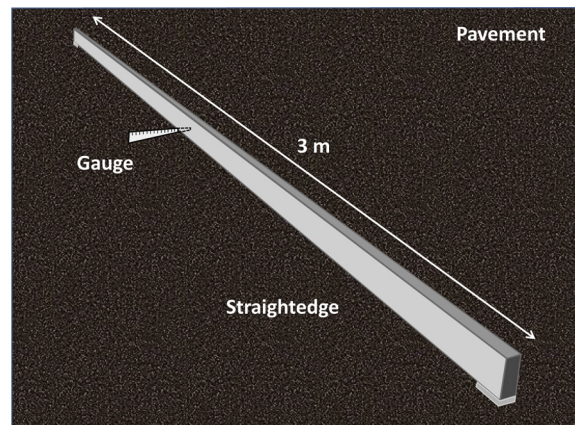

Fig. 5. Scheme of fixed length straightedges.

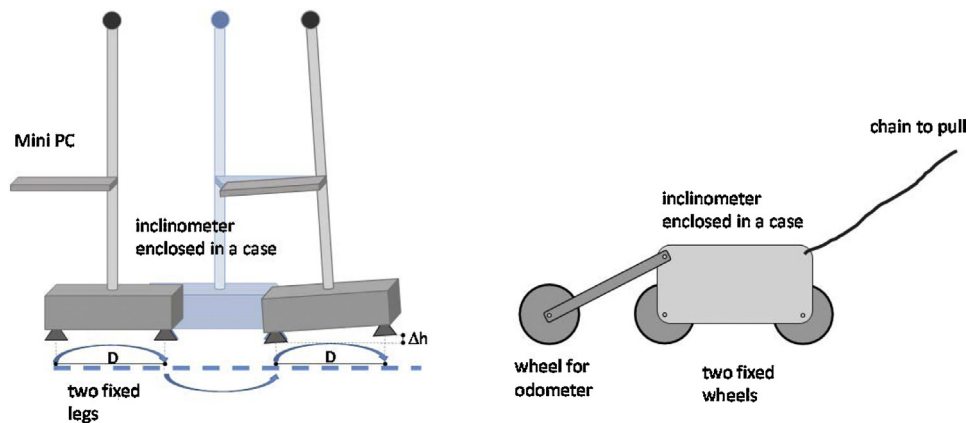

Fig. 6. Schemes of two kinds of profilometers: "walking" (left) and "rolling" (right).

- measurements are discontinuous;
- statistical treatment of the data is not allowed;
- the evaluations depend on a fixed measure base and therefore they do not allow to consider the geometrical imperfections due to other defects or other dimensions of measure;
- the measurements require a long time;
- results are highly operator-dependent (the operator decides where the measures have to be taken) and therefore they often can generate some disagreements;
- the observation of different surface performances, according to possible usage conditions, is not allowed.

More recent evaluation methods, that are actually widely used, are based on the precise measure of the surface "(x, y) profiles", on the pavement, by means of traditional methods (rod and level) or using some special digital equipment that has been properly developed for these purposes (profiler, profilometers, or profilograph).

The most used devices for surveys are classified as "contact profilometers"; they measure the inclination of two points along the pavement with respect to a known base, so calculating their difference in height. The two fixed points that identify the base of measure may move on the floor through successive rotations (leaving a fixed point and moving the other of 180°): for this reason the instruments are called "walking profilometers"; alternatively, the inclinometer can be installed on a system of wheels (so-called "rolling profilometers") that allow faster measurements. For these described instruments, the longitudinal interval normally adopted as base of measure is 300 mm.

In Fig. 6, the two schemes of profilometers for the measure of paved surfaces regularity are shown: on the left there is a "walking" instrument; on the right a "rolling" one is presented. Both the two commercial instruments are equipped with specific software that allows the calculation of the indexes so characterizing the pavement flatness and levelness.

In Fig. 7, two different profiles on a concrete pavement, obtained by a walking profilometer, are presented. Similar diagrams can be also obtained by means of the other kinds of profilometers.

The assessment methods proposed above, however, are limited in the density of their measurements and, for this reason, other instruments and methods are now developing in order to improve the control process of concrete floors. For example,

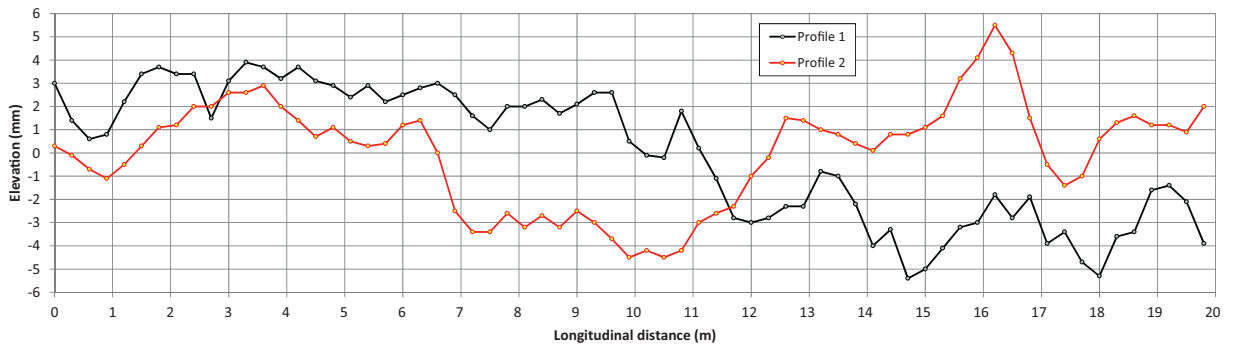

Fig. 7. Examples of profiles measured with a contact walking profilometer on an industrial floor.

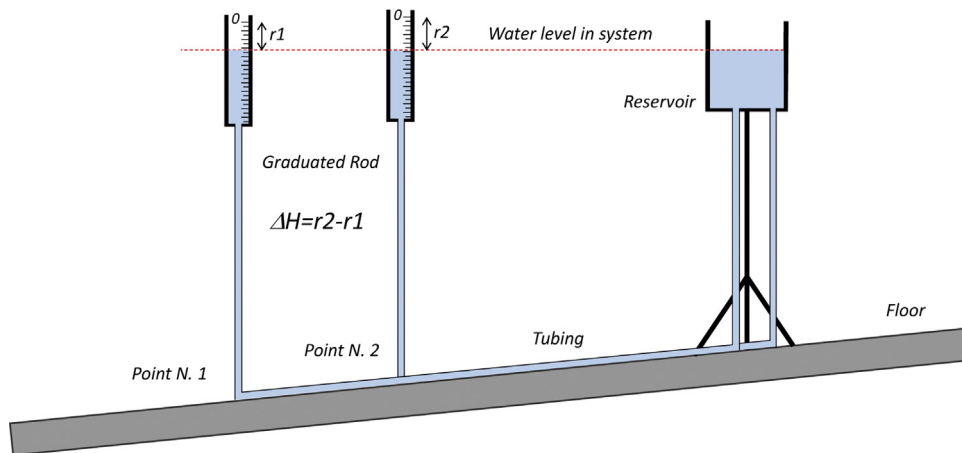

Fig. 8. Scheme of water level manometer measurement system.

laser scanners are general-purpose instruments for densely and accurately measuring three-dimensional shapes. Tang et al. in [3] show how laser scanners can be effectively used to assess surface flatness. They formalize, implement, and validate three algorithms for processing laser-scanned data to detect surface flatness deviations.

For levelness measurements, also a water level manometer device can be used; it consists of a large reservoir of water on an adjustable stand, connected by a plastic tube to a graduated rod [4]. The elevation difference between two points then can be found by comparing the readings on the graduated rod when it is held vertically at each point. The water level manometer is schematically showed in Fig. 8.

In any case, profilometers can be considered the most used and versatile instruments; they are useful for measure the surface geometry of concrete floors and pavement slabs. The advantages of these instruments are related to their good performances, in order to obtain both the reference variables (flatness and levelness) that characterize the regularity of concrete floors.

It is important, however, to consider that the measurements obtained by profilometers or other devices, without a proper treatment of the data, do not allow to formulate objective judgments regarding the flatness and/or levelness of the floors. For example, a simple visual comparison between the two profiles showed in Fig. 7 suggests that the levelness of the profile 1 (in black) seems better than that of the profile 2, if it is measured with a base of 3 m (the profile 2 presents a peak due to a constructional joint near to the point #16); instead, probably, the profile 2 is better than the profile 1 with regard to the flatness referred to a base of 300 mm, because of minor differences in height between adjacent points. In the following paragraph the general principles, regarding the methodologies used to critically evaluate the flatness and levelness properties, will be presented.

Finally, regarding the irregularities that are located near to the joints of the slabs, special attention for measures and controls are needed for two reasons: the first is a forensic reason [4,5], related to the significance of measures in case of possible disputes referred to the performances of the construction process [6]. The second reason is typical for the slabs used for roads and airports, as such the defects in these cases can lead to dynamic effects in the loads which accelerate the decay of the pavement [7], and they can also produce detrimental consequences for users [8] (comfort, noise, vibration, etc.).

3. Data evaluations, assessment, and standard references

To get an objective assessment of the parameters that express the regularity of a measured profile, it is necessary to calculate the two main variables (“flatness” and “levelness”), starting from the data obtained by means of profilometers. The evaluation criteria, for these two variables, are presented in the technical standards. In particular [9], it needs to measure, for many points along the selected alignments, the differences in elevations or profile curvature (q) and the elevation differences (z) between all considered points, having a spacing of 3 m. On this data set, a statistical process has to be performed. This process consists, essentially, in the calculation of the two basic statistic variables:

- μ : absolute value of the mean of the values in the sample;
- S : standard deviation or square root variance of the values in the sample.

The standards present the requirements for the surveys over a pavement, in order to obtain a statistically significant number of elevation measures, and to evaluate, in function of the dimension and shape of the surveyed surface, the flatness and the levelness. The property used to evaluate the levelness along a profile, seen before, can be evaluated also across the path of handling equipment, considering two parallel profiles, with the aim to control the differences in height between the left and right-hand wheel tracks of a forklift truck. This is, in particular, the preferred method for surveys when the evaluation of performance concerns some defined-movement areas in an industrial floor. Measurement and evaluation standards regarding floors flatness and levelness have only been developed in the US [10], UK [1], France [11], and Germany [12,13]. The US and UK standards are very similar and they are widely used around the world. The German and French standards are only used respectively in Germany and France and in some other parts of Europe. The characterization methods and the allowable limits, for pavement regularity indexes evaluation, are different in the case of free movement floors or in the case of defined traffic floors. In the case of defined traffic floors the methods of measure and the data process are not particularly difficult; generally, the standards describe how the survey data has to be analyzed and compares the results with the limits referred to levelness and flatness properties, evaluated on the basis of geometric profile data. For example, the British Standard (TR 34) establishes that a floor is non-compliant if:

- more than 5% of the total number of measurements exceed the 95% flatness property limit;
- any measurement exceeds the 100% flatness property limit, and
- any point on the levelness property survey grid is outside ± 15 mm of datum.

Neglecting in this paper the cases of defined traffic floors, the US standards seem more complete and general in order to evaluate the floor’s flatness and levelness. In free movement floors, it is not possible to measure or verify the indexes on the basis of the infinite geometries obtained by linking the points on the floor; therefore, a sample of linear profiles on the surface of the floor should be measured. For this aim, first of all the ASTM 1155M recommends where and how the data have to be collected, and how many samples are necessary. Given this method is a statistical process, it is not possible to perform infinite measurements, so it is necessary to specify how the profile measurements on the floor have to be organized. Generally the floors are very large areas and for this reason it is opportune to divide the whole area as subsets of sections having appropriate geometric dimensions (for example, corresponding to the size of the slabs). For each test sample line the Floor Flatness Number F_F and the Floor Levelness Number F_L have to be calculated, on the basis of following equations:

Flatness Number:

$$F_F = \frac{115.85}{3 \times S_{q_k} + |\mu_{q_k}|} \text{ (dimensionless)} \quad (1)$$

Levelness Number:

$$F_L = \frac{314.67}{3 \times S_{z_j} + |\mu_{z_j}|} \text{ (dimensionless)} \quad (2)$$

where: “ μ ” and “ S ”, as before defined, are respectively the mean values and the square root variance of curvatures (q) and elevations (z) along the profiles selected as test sample lines. Generally, in a test section there are several test sample lines, but it is necessary to assign a single value for flatness and levelness numbers. If the test sample lines have the same number of elevation measurements then it is possible to indicate simply the mean of the calculated values. But, if the test sample lines have not the same number of elevation measurements then it is necessary to take into account the different statistical weight of the measures. The following equation, included in the standard, can be used to combine the F_F Flatness or F_L Levelness F -Number estimates derived from two different test samples (a and b) into a single composite F -Number estimate:

$$F_{a+b} = F_a \times F_b \times \sqrt{\frac{r_a + r_b}{r_b \times F_a^2 + r_a \times F_b^2}} \quad (3)$$

where

F_{a+b} = F -Number estimate derived by combining Samples a and b ,

F_a = F -Number estimate derived from Sample a ,

Table 1
FF and FL limits for different buildings and uses [14].

Flatness F_F	Levelness F_L	Typical use
20	15	Non critical: mechanical rooms, nonpublic areas, surfaces to have raised computer flooring, surfaces to have thick-set tile, and parking structure slabs
25	20	Carpeted areas of commercial office building or lightly-trafficked office/industrial buildings
35	25	Thin-set flooring or warehouse floor with moderate or heavy traffic
45	35	Warehouse with air-pallet use, ice, or roller rinks
>50	>50	Movies or television studios

Table 2
Results of measurements on Floor No. 1.

	$\mu(q)$	S(q)	$\mu(z)$	S(z)	F_F (45)	F_L (35)	diff % F_F	diff % F_L
<i>cmr1</i>	0.035	1.164	0.480	2.118	32.8	46.1		
<i>cmr2</i>	0.022	0.985	-1.527	2.237	38.9	38.2		
<i>cmr3</i>	-0.009	1.153	1.073	0.493	33.4	123.2		
<i>cmr4</i>	0.013	0.872	4.360	2.309	44.1	27.9		
<i>cmr5</i>	0.052	1.234	-1.400	1.063	30.9	68.6		
<i>cmr6</i>	0.104	1.090	-2.687	3.411	34.3	24.4		
<i>cmr7</i>	0.022	1.178	-1.807	1.168	32.6	59.2		
<i>cmr8</i>	0.043	0.852	-1.173	1.749	44.6	49.0		
<i>cmr1-4</i>	0.020	1.051	1.860	1.941	36.5 (31.8 41.2)	39.9 (33.4 46.4)	10%	7%
<i>cmr5-8</i>	0.055	1.098	1.767	2.073	34.6 (30.1 39)	39.2 (32.9 45.6)	12%	6%
<i>cmr1-8</i>	0.038	1.075	1.813	2.008	35.5 (32.5 38.6)	39.6 (35.2 44)	11%	7%

The green numbers agree with the standard; the red numbers are out of the limits.

F_b = F -Number estimate derived from Sample b ,

r_a = number of q_k or z_j readings in Sample a used to derive F_a , and

r_b = number of q_k or z_j readings in Sample b used to derive F_b .

Using the Eq. (3), it is possible to calculate the composite F_F Flatness Number estimate for each test section by combining (iteratively) all the flatness F -Number estimates, obtained from single test samples within each test section. In the Fig. 8, an example of the composite F_F Flatness Number calculations, starting from the F_F value for 6 test sample lines (obtained with reference to a different numbers of elevation measurements: r_1, r_2, \dots, r_6), is showed.

Finally, the analysis procedure provides a statistical-based assessment and therefore, it is necessary to produce results in terms of indexes, associated to a proper confidence interval.

The following equation, included in the standard, allows to calculate the 90% confidence interval, $CI_{90\%}$, associated with each F_F Flatness and F_L Levelness Number estimates:

$$CI_{90\%} = -1.82 \times (\log_{10} r)^3 + 19.4 \times (\log_{10} r)^2 - 71.69 \times (\log_{10} r) + 92.62\% \quad (10)$$

where r = total number of q_k or z_j points, used to calculate the F_F or F_L Number.

$$F_{F,L90\%} \text{ConfidenceInterval} = \left[\frac{(100 - CI_{90\%})}{100} F_{F,L}; \frac{(100 + CI_{90\%})}{100} F_{F,L} \right] \quad (11)$$

For the example of Fig. 8, the obtained statistical parameters are:

$CI_{90\%} = 14.96$; F_F Number $_{90\%} = 29.0$; so the resulting Confidence Interval is [24.7; 33.4].

4. Floor Flatness/Levelness tolerances, statistical interpretation of results

Depending on the building type, different minimum values for F_F and F_L are needed. In the technical specifications, the F -number pair is always written in the order F_F/F_L . In Table 1 the values established by the ACI [14,15] for slabs on grade are shown.

Since the measured F -Numbers are lower than the specified F -Numbers, then not all the 100% of the slab fails the specified F -Numbers. Conversely, if the measured F -Numbers are higher than the specified F -Numbers, then not all the 100% of the slab exceeds the specified F -Numbers. In fact, it is important to remember that these indexes are statistical parameters and they should be interpreted as such. If the F -number measured is lower than the established one, it is possible to calculate the percentage of measurements that are below or exceed the specified value.

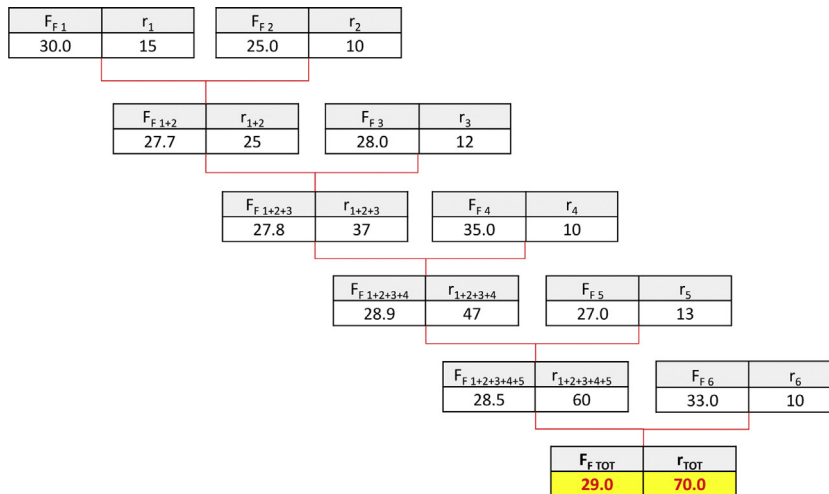

Fig. 9. Example of calculation of the composite F_F Flatness Number, for 6 test sample lines.

To calculate this percentage it needs to compare two Gaussian curves: the first one is referred to a theoretical floor that has the same F -number specification (standard) value (SV). The second one is the Gaussian curve calculated with the F -number measured value (MV). This second curve is obtained from the surveyed data on the floor. The two intersecting probability curves define three separate areas (Fig. 9) that exactly correspond to the relative percentage compliance between the two floors (measured and theoretical):

- Area “A” – the area under both curves: it represents the fraction of both floors containing exactly the same distributions.
- Area “B” – the area under the SV curve only: it represents the fraction of the floor that contains smaller values (better) than those found in an F -number measured floor. This is the percentage of a theoretical floor that is better than the measured floor.
- Area “C” – the two “tail” sections under the F -number measured curve only: it represents the fraction of an F -Number measured floor containing values that are larger (worse) than those found in an F -Number SV theoretical floor. This is the percentage of an F -Number measured floor that is worse than the F -Number SV theoretical floor.

5. Case study: alternative methods for flatness and levelness improvement

The examined case study concerns a floor of slabs for a warehouse constructed in Italy and having a total surface of about 3000 m². The floor should achieve the following limits regarding flatness and levelness:

$$F_F = 45 \text{ and } F_L = 35$$

In Italy, this type of limit is not common and then the builder decided to check in advance some test sites, having limited size, in order to identify the most appropriate construction techniques. Unfortunately, the results of the measurements in these sites did not give good results. Therefore, it was decided to use corrective measures in order to improve the flatness and levelness values, also maintaining the usual construction techniques for concrete slabs.

Referring to this case study, the images and the results of the measurements on three samples of rectangular surfaces, belonging to the examined concrete floor, are presented in the following:

Floor No. 1 (Fig. 10): that is one of the test sites where the flatness and levelness indexes were not completely achieved.

Floor No. 2 (Fig. 11): it is one of the above mentioned test sites where a surface grinding treatment was made because the flatness and levelness indexes were not completely achieved.

Floor No. 3 (Fig. 12): it is one of the above mentioned test sites where an overtopping with self-levelling and high resistance resin treatment was made, because the flatness and levelness indexes were not completely achieved.

The first surface, examined in this case study, measures 20 × 8.4 m. On this area, 8 sample measurement lines 7.2 m long were defined; they were located as showed in the Fig. 13.

The results of performed measurements are summarized in Table 2, where the values obtained of indexes F_F and F_L are presented, in comparison (in percentage) with the required ones.

For the F_L values, the specification value was not achieved only for two sample measurement lines. As regards to the total results, obviously the floor does not satisfy the flatness specification while the levelness specification was achieved. The values in the last two columns of Table 2 indicate that the 10, 12, and 11 percent of the floor is below of the specified F_F value of 45 and the 7, 6, and 7 percent of floor exceeds the specified F_L of 35. The values of F_F obtained by the 8 samples

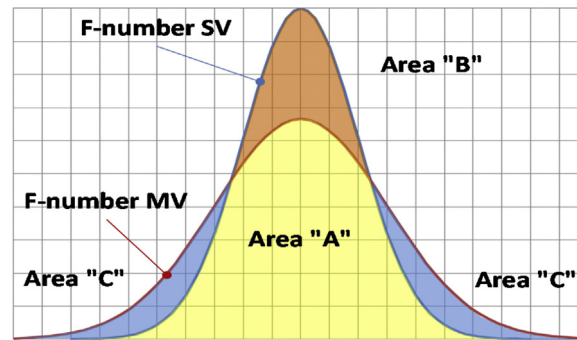

Fig. 10. Statistical interpretation of results.



Fig. 11. Photo of the first examined surface without treatment (Floor No. 1).



Fig. 12. Photo of treatment by means of surface grinding (Floor No. 2).

indicate that this index is fairly homogeneous across the floor, contrarily to the F_L , for which there is a significant variation of the measured values (from 24.4 to 123.2).

Similar results were obtained also in the other test sites; then, the judgment was that the construction technique adopted by builder for these concrete floors was not suitable to achieve the required limits regarding flatness. For this reason, after many attempts it was decided to find a solution in order to increase the flatness and levelness while maintaining the same functional and structural characteristics of the floor; therefore, two different treatments for the surface were experimented within two test sites.

The measurements on these two other test surfaces were examined according to the scheme of measurements presented in Fig. 14; the results obtained after the treatments, in terms of F_F and F_L , are presented in Tables 3 and 4. For the “surface grinding”, the results summarized in the Table 3 show that in 6/8 sample measurement lines the F_F values finally achieve the specification value. About the F_L values, only for one sample measurement line the specification value is not achieved. As regards to the total results, in the floor both flatness and levelness specifications are achieved. Considering the F_F and F_L values, the grinding seems to have had a better effect in one direction (lines 1–4) compared to the other one (lines 5–8).



Fig. 13. Photo of a treatment by overtopping with self-levelling and high resistance resins (Floor No. 3)

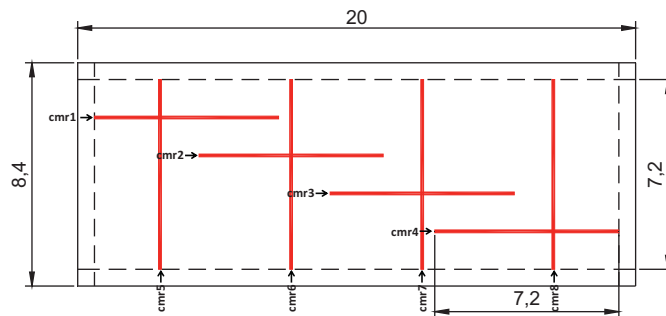

Fig. 14. Scheme of the Floor No. 1.

Table 3

Results of measurements after the treatment: “surface grinding” (Floor No. 2).

	$\mu(q)$	$S(q)$	$\mu(z)$	$S(z)$	F_F (45)	F_L (35)	diff % F_F	diff % F_L
cmr1	0.070	0.791	-1.493	2.192	47.5	39.0		
cmr2	0.030	0.786	-0.593	1.223	48.5	73.8		
cmr3	-0.004	0.615	1.373	2.252	62.6	38.7		
cmr4	-0.035	0.478	3.140	0.942	78.8	52.8		
cmr5	0.000	0.851	-4.107	2.536	45.4	26.9		
cmr6	0.070	0.855	-1.593	1.361	44.0	55.4		
cmr7	0.148	0.922	1.387	2.089	39.8	41.1		
cmr8	0.048	0.789	-1.920	1.841	48.0	42.3		
cmr1-4	0.035	0.680	1.650	1.751	55.8(48.663.0)	46.3(38.853.8)	10%	16%
cmr5-8	0.066	0.855	2.252	2.002	44.0(38.349.6)	37.4(31.3 43.5)	1%	6%
cmr1-8	0.051	0.773	1.951	1.881	48.8(44.653.0)	41.1(36.6 45.7)	4%	11%

The green numbers agree with the standard; the red numbers are out of the limits.

For the treatment “*overtopping with resins*”, the results summarized in the Table 4 show that for all the sample measurement lines, the F_F values achieve the specification value. About the F_L values, only for one sample measurement line, the specification value is not achieved. As regards the total results, in the floor both flatness and levelness specifications are achieved. Considering the F_F and F_L values, also this treatment seems to have had a better effect in one direction (lines 1–4) compared to the other one (lines 5–8). In this case, this very high difference may be due to the cast direction of one of the layers that were laid to realize the treatment.

Both of the proposed solutions are able to ensure, within certain limits, the fulfillment of the requirements: the “*surface grinding*” treatment does not change the original characteristics of surface but it has less margin of improving compared to the other considered treatment. In addition, the “*surface grinding*” treatment can be applied only where the problems arise; on the contrary, the “*overtopping with resins*” treatment should be applied over the whole surface and it changes the functional properties of the floor (even better) (Fig. 15).

Table 4

Results of measurements after the treatment: "overtopping with resins" (Floor No. 3).

	$\mu(q)$	S(q)	$\mu(z)$	S(z)	F_F (45)	F_L (35)	diff % F_F	diff % F_L
cmr1	0.014	0.249	-0.343	0.571	152.1	153.1		
cmr2	-0.014	0.181	0.093	0.379	208.4	255.7		
cmr3	0.000	0.183	-0.843	0.781	211.5	98.7		
cmr4	0.027	0.207	-0.871	1.287	178.3	66.5		
cmr5	0.073	0.553	-2.100	2.245	66.9	35.6		
cmr6	-0.014	0.591	-1.171	1.760	64.8	48.8		
cmr7	-0.027	0.623	-2.121	1.762	61.1	42.5		
cmr8	0.032	0.524	-2.121	2.538	72.2	32.3		
cmr1-4	0.014	0.207	0.538	0.827	182.5(159.1206.0)	101.7(85.2 118.2)	53%	53%
cmr5-8	0.016	0.574	1.879	2.103	65.9(57.474.4)	38.3(32.1 44.6)	18%	6%
cmr1-8	0.025	0.431	1.208	1.598	87.7(80.195.2)	50.7(45.1 56.4)	33%	23%

The green numbers agree with the standard; the red numbers are out of the limits.

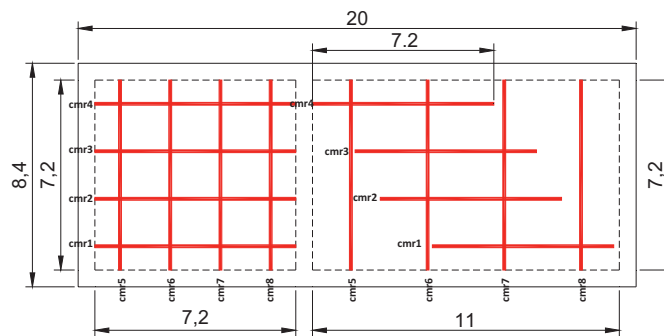

Fig. 15. Scheme of measurement performed after the treatments (grinding treatment on the left and self-levelling resin treatment on the right).

6. Conclusions

In the construction of concrete pavements for industrial floors, it is important to ensure some functional properties regarding the surface regularity, that have the same importance as the mechanical and structural characteristics. Goods storage capacity and operational conditions in warehouse and logistic centers, in fact, can be significantly influenced by the conditions of floors' surfaces.

Two parameters are useful to characterize these important properties: the "levelness", that indicates the surface regularity over a distance equal or more than 3 m, and the "flatness", used to evaluate the regularity over a distance typically equal to 300 mm. The definition of both the two variables is generally based on measurements along some selected alignments (surfaces profiles), that are actually performed by means of special equipment (contact profilometers, usually), and on the calculations of differences between the height of points on the real surface and those on an ideal reference plan. The evaluation of flatness and levelness, along the selected profiles on a paved surface, can be achieved by means of some indexes established by the technical standards. In particular – following the procedures of the ASTM 1155M – two indexes named F_F and F_L can be used; these indexes allow to obtain a concise and expressive representation of the functional properties concerning the floors' regularity. However, considering that measurements can be locally affected by various specific problems and they can be not really representative of the functional performances, it is necessary to perform a statistical process consisting in the calculation of the two basic statistic variables: the mean and the standard deviation of the values in the sample.

In this paper, after a revue of the principles regarding the functional performances for industrial floors and some indications to the standard requirements for data acquisition and processing, three surfaces belonging to an industrial concrete floor were presented as a case study. For these test sections, the indexes of flatness and levelness were determined, with the purpose to evaluate the efficacy of two possible improving treatments: the surface grinding and the overtopping with self-levelling and high resistance resins. After the completion of these actions, other measurements and evaluation were performed and the results allowed to compare the different achieved levels of flatness and levelness and to demonstrate the advantages of the experimented treatments.

In general, the presented procedures demonstrated their real usefulness for the proposed aims, consisting in the characterization – in a functional sense – of the surfaces performances of the industrial floors. The indexes F_F and F_L (generally indicated as F -Number in the technical standards) and their statistical meaning, result in very immediate and practical

parameters for the definition and control of the required performances. These procedures can be used to establish and verify the quality of concrete pavements surfaces and can contribute to prevent some debates or disagreement between the various subjects interested to their technical characteristics (owner, constructor, operator, etc.).

References

- [1] TR34, Concrete Industrial Ground Floors a Guide to Design and Construction, 3rd edition, Report of a Concrete Society, United Kingdom, 2003.
- [2] G. Garber, Design and Construction of Concrete Floors, Elsevier, 2006.
- [3] P. Tang, D. Huber, B. Akinci, Characterization of laser scanners and algorithms for detecting flatness defects on concrete surfaces, *J. Comput. Civil Eng.* 25 (1) (2010) 31–42.
- [4] K.D. Walsh, H.H. Bashford, B.C. Mason, State of practice of residential floor slab flatness, *J. Perform. Constr. Facil.* 15 (4) (2001) 127–134.
- [5] K.D. Walsh, Performance of methods for analysis of relative floor elevation measurements in residential structures, *J. Perform. Constr. Facil.* 21 (5) (2007) 329–336.
- [6] E.T. Marsh, S.A. Thoeny, Damage and distortion criteria for residential slab-on-grade structures, *J. Perform. Constr. Facil.* 13 (3) (1999) 121–127.
- [7] G. Bonin, G. Cantisani, G. Loprencipe, A. Ranzo, Dynamic effects in concrete airport pavement joints, *Ind. Ital. Cemento* 77 (834) (2007) 590.
- [8] G. Cantisani, G. Loprencipe, Road roughness and whole body vibration: evaluation tools and comfort limits, *J. Transp. Eng.* 136 (9) (2010) 818–826.
- [9] A. Face, Floor flatness and levelness: the *F*-number system, *Constr. Specifier* 40 (April (4)) (1987) 124–132.
- [10] ASTM, 1155M-96, Test Method for Determining FF Floor Flatness and FL Floor Levelness Numbers (Metric), ASTM International, West Conshohocken, PA, 2003, 2008, <http://dx.doi.org/10.1520/E1155-96R08>, <www.astm.org>.
- [11] NIT 204, Sols industriels à base de ciment, Centre Scientifique et Technique de la Construction, Bruxelles 1997.
- [12] Deutsches Institut Fur Normung Lagersysteme mit leitlinengefuhrten flurforderzeugen (Warehouse systems with guided industrial trucks: requirements on the ground, the warehouse and other requirements), DIN 15185, Beuth Verlag, Berlin GmbH, Berlin, August 1991 7pp.
- [13] Deutsches institut fur normung, Toleranzen in hochbau, Bauwerke, (Tolerances for buildings, Structures) DIN 18202, Beuth Verlag, Berlin GmbH, Berlin, April 1997 (English translation) 8pp.
- [14] American Concrete Institute ACI 302.1R-96, Guide for Concrete Floor and Slab Construction, Farmington Hills, 1996.
- [15] American Concrete Institute ACI 117-90, Standard Specification for Tolerances for Concrete Construction and Material, Farmington Hills, 1990.