

## AN ELECTRONIC TELEMETRY SYSTEM USING A LAPTOP FOR INVESTIGATION OF KINEMATIC AND KINETIC STUDIES OF SPRINTERS

Morteza Shahbazi-Moghaddam<sup>1</sup> and Fraydoon Javashi<sup>2</sup>

<sup>1</sup>Tehran University Physics Department and Physical Education Sport and Leisure Studies of Edinburgh University. <sup>2</sup>Electrical Department of Lahijan Azad University

The purpose of this study was to design an electronic telemetry system in order to investigate kinematics and kinetic characteristics of sprinters. Ten FM transmitters with the frequency range of 98-108 MHz have been designed and constructed for time interval capturing in conjunction with an adequate interface including a FM receiver and pulse shaping, and a laptop computer. With the help of C program, we could profit the internal clock of the computer. A video camera at 30 Hz was also used to capture data for investigation of reaction, stopping and take-off mean forces of each leg. The kinematics curves showed that how the sprinters ran a 100m run, when they reached their maximum speed, how long they could maintain this speed, and when the acceleration begins to be negative, while the kinetic results showed that in maximum speed, the longer the stride length is, the larger are the forces.

**KEY WORDS:** acceleration, velocity, average forces, CG flight angle, sprinters.

**INTRODUCTION:** Electronic devices are widely used in sports training and applied research, to measure running, walking, jumping and skiing velocities. Ten transmitters with adequate power (0.5 watt at 100MHz), were designed and distributed in every 10m distance intervals. Each of these transmitters is controlled by a lens and a photocell with an adequate amplifier. The transmitters are normally at off position, but whenever a sprinter is in the view of the lens, the corresponding transmitter turns on sending an electrical signal to the receiver. Ten signals present ten time intervals corresponding to ten distance intervals of 10 meters each. The transmitters are in the same condition and are sensitive to the body of sprinters that means, whenever the body of sprinter is in the field of a lens, the corresponding photocell make the amplifier conduct and send a signal. Photocells are also widely directly used in sports training and applied research to measure time and velocities in most sport skills. By combining several photocells researchers can build light curtain for time and space determination of a moving object. The measurements of release velocity and angle for flying objects such as javelins and balls have been reported by using photoelectric, computerizes on-line (Viitasalo and Korjus, 1987/1988). Another photocell computerized on-line system, the photocell contact mat (PCM) was also developed for applied research as well as for coaching purposes to measure ground contact time and flight time as well as step and stride frequency as a function of running time or running distance (Viitasalo, 1995). Another such a system was also used to measure contact and flight times in running (Viitasalo, Luhtanen, Mononen, Norvapalo, Paavolainen and Salonen. 1997). The purpose of our study was to evaluate the validity and accuracy of our system in determining the variation of velocity and acceleration of our top sprinters and finding out their behavior in a 100m running and make the comparison.

**METHODS:** The analysis of men's 100 meters events was carried out on the basis of recording obtained from 10 video cameras (60 fields/second), (Michiyoshi Ae, Akira Ito and Misano Suzuki, 1992). All cameras were synchronized with the flash of the starter's gun. They used these cameras located at 10m intervals straight along the stadium. The elapsed time of the sprinter could be achieved, then the variation of velocity could easily be traced. The proposed system consists of ten transmitters and a receiver with an adequate electronic circuit for shaping the received analog signals and put it into the computer via the external parallel port to reach the internal clock of the computer. In order to have time interval for each 10 m distance interval, ten FM transmitters have been designed and constructed. These transmitters were located at every 10m and were normally at off position. Their conduction is conditioned with a photocell which is at the focus of a lens. The photocells are incorporated in appropriate switching amplifiers which go to conduction whenever the subject

is in front of the lens. The conduction of the switching amplifiers make transmitters send a very short electrical signal which is received by the receiver, shaped and fed to the computer. Since the limit speed of our subjects occurred between 40-70 meters, therefore we have fastened a 30 meter long white paper with adequate width on the track for determining the stride's length of our subjects by measuring the distance between the trace of foot prints. The stride length measurement was necessary for calculation of ground reaction and muscle forces. At limit speed the subjects ran at constant speed and therefore at constant stride length. The video camera was Panasonic M9000 with the shutter speed at 1/500 second and was installed at appropriate distance in order to have 20 meters in view. The subjects wore white stretch with black land marks on ankle, knee and hip. By using a video projector and engineering tools we were able to estimate ground and muscle forces. We have used the formulae suggested by Shahbazi et al. (1998) for obtaining CG(Center of Gravity), take-off angle and the vertical velocity component ( $V_{yo}$ ) which at touch down becomes zero. This component is also used for the estimation of muscle force. These formulae are as following;

$$F_R = M (V_{yo}/t) + Mg \quad (1)$$

$$F_m = M (V^2_{yo}/2h) + Mg \quad (2)$$

$t$  is the touch down time measured by the video camera,  $h$ , is the displacement of CG relative to the stance position.  $F_R$  and  $F_m$  are the reaction and muscle forces respectively.

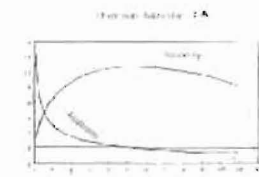

Figure 1 - Velocity and acceleration versus time of subject A.

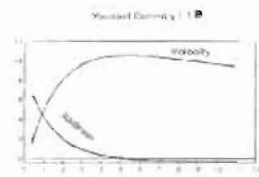

Figure 2 - Velocity and acceleration versus time of subject B.

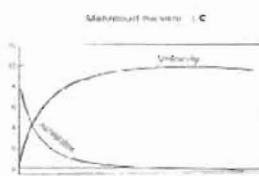

Figure 3 - Velocity and acceleration versus time of subject C.

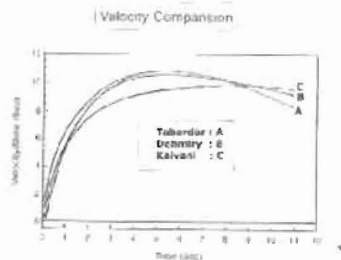

Figure 4 - The velocity comparison of three subjects

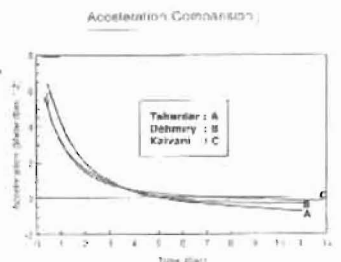

Figure 5 - The acceleration comparison of three subjects.

**RESULTS AND DISCUSSIONS.** We have presented on Figures 1, 2, 3, the variations of velocities and accelerations versus time together to see that at the limit speed the acceleration becomes zero and also showing that when approaching the end of the run, it tends to the negative values. On Figures 4 and 5, the comparisons of accelerations and velocities are presented. As we can notice the runner C, tried to keep running with his limit speed but he lost, as a whole, his record. On the contrary, the runner A, showed a noticeably acceleration at start, but he could not keep his limit speed for longer time. On Table 1 we

have presented the values of mechanical parameters. On Figure 6, the schematic of proposed transmitter is presented.

**Table 1.** Mechanical parameters, reaction, stopping, and take-off muscle forces.

Subjects	Strides Length m.	Strides Time m Sec.	Touch-Down m Sec.	C.G. Angle deg.	V <sub>yo</sub> ms $\parallel$ .	C.G. Displace. m.	FR N.	F <sub>m</sub> Stopping N.	F <sub>m</sub> T-O N.
A	2.35	212	125	5.46	1.05	0.18	1266.8	1894.8	1614.0
B	2.18	198	133	5.32	0.97	0.16	1088.5	1481.5	1635.5
C	1.95	187	139	5.12	0.93	0.17	1095.5	1522.5	1333.6

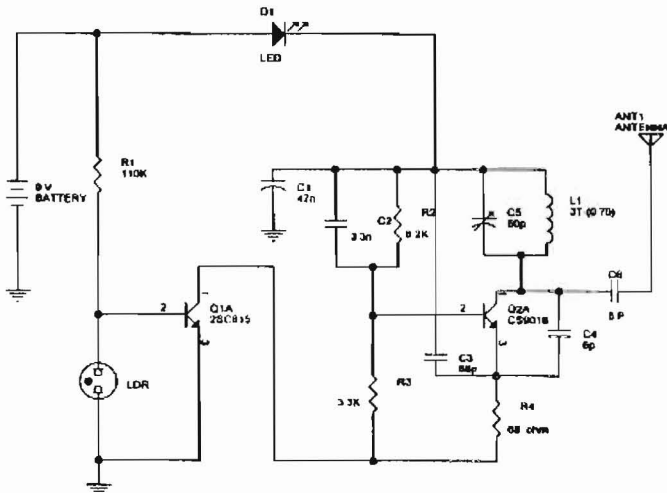

**Figure 6.** The schematic of proposed transmitter used for the time collections.

**CONCLUSIONS.** The proposed method is inexpensive comparing with other methods and is very simple and easy to use. Mechanical parameters such as ground reaction, stopping and take-off forces are readily estimated. The results can be combined with body kinematics and anthropometric models to give average joints forces and torques.

## REFERENCES

- Shahbazi-Moghaddam, M., Broogeni, N. (1998). A New Biomechanical Aspect for Assessing Mechanical Parameters in Long-Jump. *Proceedings of ISBS*. Konstanz, Germany.
- Shahbazi-Moghaddam, M., Azari, A. and Hemmatinejad, M. (2000). An Investigation of Forces, Torques and Work through Biomechanical Indirect Measurements in Backward Somersault. *Proceedings of ISBS*, Hong Kong.
- Viitasalo, J.T. (1995). On-line Measurement of Stride Characteristics during Running by Photocell Contact Mat. *In Third IOC World Congress on Sport Sciences; Congress Proceedings*. Atlanta, GA: The Document Company. 89-90.
- Viitasalo, J.T. & Korjust, T. (1997). Measurement of Release Velocity and Angle in the Javelin. *Leistungssport*, 4, 39-40.
- Viitasalo, J.T. & Korjust, T. (1998). On-line Measurement of Kinematic Characteristics for Javelin. *Biomechanics XI*, 582-587. Amsterdam; Free University Press.

**Acknowledgement:** This work has been partially supported by the Research Council of Tehran University and mainly supported by the Research Council of Lahijan Azad University. The authors are thankful to Mrs. Zahra Amin and Mr. Mahyar Nirooee for their help in data collections and performing the designed circuits. The administrative assistance of Dr. Afshar and Dr. Bidarigh is greatly appreciated.