

DESIGN OF PORTABLE HUMIDITY CONTROL CHAMBER

By

WAN HATIFAH HANIN BT WAN HASSAN

FINAL REPORT

Submitted to the Electrical & Electronics Engineering Programme
in Partial Fulfillment of the Requirements for
the Degree
Bachelor of Engineering (Hons)
(Electrical & Electronics Engineering)

Universiti Teknologi Petronas
Bandar Seri Iskandar
31750 Tronoh
Perak Darul Ridzuan

© Copyright 2007

by

Wan Hatifah Hanin bt Wan Hassan, 2007

CERTIFICATION OF APPROVAL

DESIGN OF PORTABLE HUMIDITY CONTROL CHAMBER

by

Wan Hatifah Hanin bt Wan Hassan

A project dissertation submitted to the
Electrical & Electronics Engineering Programme
Universiti Teknologi PETRONAS
in partial fulfilment of the requirement for the
Bachelor of Engineering (Hons)
(Electrical & Electronics Engineering)

Approved:



Dr. John Ojur Dennis
Project Supervisor

UNIVERSITI TEKNOLOGI PETRONAS
TRONOH, PERAK

June 2007

CERTIFICATION OF ORIGINALITY

This is to certify that I am responsible for the work submitted in this project, that the original work is my own except as specified in the references and acknowledgements, and that the original work contained herein have not been undertaken or done by unspecified sources or persons.



Wan Hatifah Hanin bt Wan Hassan

ABSTRACT

The title of this Final Year project is 'The Design of Humidity Control Chamber'. This system is created initially to provide a proper environment for the sensor to work; the idea has been expanded so that it can be used as a humidity control chamber. By providing different levels of humidity, user will get to choose and set the required humidity level in the range from 0 to 99%RH. To offer these useful functions, the system has been built as a combination of a water bubbler system, test chamber, valve system, and proper tubing; all are controlled by a pre-programmed PIC microcontroller. A standard relative humidity sensor is located inside the chamber to provide inputs to the PIC. Current percentage of relative humidity and temperature will be displayed by LCD Display connected to the PIC. An electronic keypad will be connected as the interface for users to key in inputs. The test system is then to be connected to dry air supply to start functioning as needed. The project has been started with literature reviews on the basic concept of humidity, the importance and current market trend, with sets of experiments done to strengthen the fundamentals during Final Year Project 1. During the second semester, the focus is more on the compact, portable and practical design of the system. The controller circuit is then constructed and connected to the mechanical parts so that the whole system can work automatically the moment an input from user is received.

ACKNOWLEDGEMENTS

In name of Allah the Almighty, the first deepest appreciation goes to Him for giving me such great strength and determination to endure all of the hardships during the two Final Year Project semesters and for the final completion of the project.

Thousands of thanks to my supervisor, Dr. John Ojur Dennis for his endless support and guidance towards the completion of the project. Under his supervision, all of the ideas, comments and directions have helped me so much in my effort to produce best results out of my Final Year Project. Special thanks to Mr. Patrick Sebastian for guiding me throughout the completion of the C programming for this project. My utmost appreciation to all Electrical and Electronics technicians, Mr Isnani, Mr. Azhar, Mr. Yassin, and not to forget Miss Siti Hawa for her helpful assistance and sincere support. Thank you to Mr. Zaaba from Chemical Department too, for his patience and willingness to guide me in conducting experiments in the chemical laboratory.

Due to some collaboration in the project, I also wish to extend my deepest gratitude to Mohd Zul Yusri bin Mohd Akhir, for his full cooperation, continuous love and support throughout the two challenging semesters. Millions of thanks to my family, especially to my parents, Wan Hassan Wan Ali and Hasmah Abdullah, for their encouragement and tolerance in many ways. And to my friends who have spent some time listening to my ideas, giving comments and contributing some thoughts for my project, I would to convey cordial gratefulness to all of you.

Lastly, thank you to everyone who has contributed to the successfulness of this project; both directly and indirectly.

Thank you.

TABLE OF CONTENTS

CERTIFICATE OF APPROVAL	ii
CERTIFICATION OF ORIGINALITY	iii
ABSTRACT	iv
ACKNOWLEDGEMENT	v
LIST OF FIGURES.....	viii
LIST OF TABLES	ix
LIST OF ABBREVIATIONS	x
CHAPTER 1 INTRODUCTION	1
1.1 Background of Study	1
1.2 Problem Statement.....	2
1.2.1 Problem Identification	2
1.2.2 Significance of the Project	3
1.3 Objective and Scope of Study	5
CHAPTER 2 LITERATURE REVIEW/THEORY	7
2.1 Basic Concept of Humidity Measurement.....	7
2.2 Relative Humidity Sensor.....	8
2.3 Temperature Sensor	8
2.4 PIC 16F877 Microcontroller	9
2.5 System Controller Circuit.....	10
2.5.1 PIC Controller Circuit.....	10
2.5.2 The Valve Transistor Switch.....	13
2.5.3 Voltage Regulator Circuit.....	14
CHAPTER 3 METHODOLOGY/PROJECT WORK	15
3.1 Procedure Identification	15
3.1.1 Mechanical Parts	16
3.1.2 Main Circuit	16
3.1.3 PIC Microcontroller	17
3.2 Tools / Equipments.....	19
3.2.1 List of hardware equipment	19
3.2.2 List of testing equipments.....	20
3.2.3 List of Software.....	20
CHAPTER 4 RESULTS AND DISCUSSION	21

4.1 Mechanical Parts.....	21
4.2 Controller Circuit.....	22
4.2.1 Construction of PIC Controller Circuit.....	23
4.2.2 PIC C Program: Compiling, Uploading and Testing	24
4.2.3 Solenoid Valves: Transistor Switching Circuit.....	27
4.3 Overall System: Testing and Troubleshooting	30
4.3.1 Using Directional Solenoid Valve	30
4.3.2 Using Normal 24V Solenoid Valve	32
4.4 Prototyping Design.....	37
4.4.1 PCB Design an Fabrication.....	37
4.4.2 Prototyping.....	39
CHAPTER 5 CONCLUSION AND RECOMMENDATION.....	41
5.1 Conclusion.....	41
5.2 Future Recommendations.....	42
REFERENCES.....	43
APPENDICES.....	44
Appendix A	45
Appendix B.....	46
Appendix C.....	47
Appendix D	48
Appendix E.....	49
Appendix F	50
Appendix G	51

LIST OF FIGURES

Figure 1 40-Pins PIC 16F877 [2]	10
Figure 2 PIC 16F877 Pin Connections[4]	11
Figure 3 PIC 16F877 LCD Display Connections [4].....	12
Figure 4 PIC 16F877 4x4 Keypad Connections[6].....	12
Figure 5 PIC 16F877 4x4 Keypad [6].....	13
Figure 6 An example of using transistor as switch	13
Figure 7 Main Methodology Flow Chart	15
Figure 8 Feedback Control Diagram.....	16
Figure 9 PIC and Main Circuit Development	18
Figure 10 PIC and Main Circuit Development	19
Figure 11 System Overall Block Diagram.....	21
Figure 12 Overall Controller Circuit.....	23
Figure 13 PICC Compiler – Including Files in Directory	25
Figure 14 Warp-13 Software.....	26
Figure 15 PIC Microcontroller Circuit Testing.....	26
Figure 16 Transistor Switching Amplifier Circuit	28
Figure 17 Test System: Testing and Troubleshooting	30
Figure 18 Asking for User Input	32
Figure 19 Displaying Current Humidity and Temperature	33
Figure 20 Graph: Humidity Sensor Output Voltage vs. %RH Displayed.....	34
Figure 21 Graph: Measured %RH vs. Required %RH.....	35
Figure 22 Controller Circuit Schematic Diagram	37
Figure 23 Controller Circuit Board	38
Figure 24 Humidity Control Chamber	39
Figure 25 Humidity Control Chamber: Top View	39
Figure 26 Humidity Test System: Front and Rear Views	40
Figure 27 Humidity Test System: Side Views.....	40

LIST OF TABLES

Table 1 Voltage and Current Ratings for Solenoid Valve.....	27
Table 2 Observations for 2N3904 NPN General Purpose Transistor (Power Supply=9V).....	28
Table 3 Observations for 2N4401 NPN Switching Transistor (Power Supply=9V) ..	29
Table 4 Observations for 2N4401 NPN Switching Transistor (Power Supply=12V)	29
Table 5 Checking the Output Voltage against Displayed %RH	33
Table 6 System Output.....	34
Table 7 System Accuracy.....	35
Table 8 System Settings	36

LIST OF ABBREVIATIONS

PIC	Programmable Integrated Circuit
PLC	Programmable Logic Controller
LED	Light Emitted Diode
PCB	Printed Circuit Board
UTP	University Technology of PETRONAS
%RH	Percentage of Relative Humidity
ADC	Analog to Digital

CHAPTER 1

INTRODUCTION

The main focus of this Final Year Project is actually on the design of a humidity test system. The explanation on how the idea is generated and elaborated will be in the first subtopic, the Background of Study, while the Problem Statement will discuss on why people need the system, and finally there will be complete list of goals and aim of the project, in the final subtopic, Objective and Scope of Study.

1.1 Background of Study

In this modern era, sensor technology has somehow stepped out in front and becomes obligatory in any environmental monitoring, process control and automation. Over the years, many great sensing methods have been developed for measuring a variety of humidity related parameters. The main objective of the project is the fabrication of a sensor that is sensitive to humidity in the environment. The sensor will be fabricated using certain materials such as metal oxide semiconductor device, and will use the resistive or capacitive properties of the material in sensing the humidity level.

As the sensor will be fabricated at UTP, there is a need of different humidity environment to measure up all corresponding voltage outputs from the sensor for different sets of humidity inputs. Only then, a standard list of output can be determined, for the sensor to be used in any application. This is where the sensor test system comes into mind, a system that is designed to supply humidity at specific levels, which of course will cause the sensor to respond accordingly.

Basically, there will be dry air supply, which will be the base, so that other levels of humidity can be measured. The sensor shall consist of four main parts, a water bubbler system, a chamber, tubing for air supply to the chamber, and also the valve system for allowing flow of dry or humid air through the chamber . Dry air will go

into water, which will eventually increase humidity in the air. The longer the user inputs the humid air, the higher will the humidity level be.

The chamber is basically a container, into which the sensor is placed, so that it would not be influenced by the environment outside. There will be an inlet and an outlet for the air to circulate through. The tubing system will be connected to the inlet, supplying the dry air and different levels of humidity at a time. Then, a valve system will be created to control the supply of the humid and dry air so that user can choose the level required to be maintained in the test chamber.

In order to enhance this sensor test chamber system, it would be controlled using PIC. Due to this, a standard humidity sensor will be included in the test chamber, so that it will be the input to the PIC controller. The output will be displayed by an LCD Display. Computer interface will be used in programming the PIC, by using CCS compiler and Warp 13 software. This kit would be design in such a way that it should be user friendly, portable and most importantly reliable. Since there are already so many kinds of humidity sensors available out there, the focus will be actually to know how to fabricate the sensor and build the system to test its response to humidity.

1.2 Problem Statement

It is believed that one will never know everything about any device, process or system, unless there is involvement in the fabrication process and completion of it. The project has been chosen after considering the relevancy and significance of the project.

1.2.1 Problem Identification

Sensors are very much useful to many applications nowadays. Technical people should be familiar with this technology; even in the early stages like students, they have been exposed to the sensors, in their projects or case studies. Sensors can be obtained easily from the market, with different ranges of prices. A question has been arisen, instead of buying, why not having our own sensor? This project has been the answer of giving opportunities to students to fabricate the sensors themselves and test

whether it can work as required.

In this case, the selected topic has been the humidity measurement, considering the importance of humidity monitoring in process control, industrial automation, and many more. There have been numerous designs in the market; this can be considered as a challenge so that student can choose the best method in fabricating the sensor. Co-project with another student who will be focusing on the materials and fabrication of the sensor itself, from there the idea of having the sensor's own test kit has been generated. By having separate focus in this project of designing the humidity sensor will benefit both students as they will have their things to do but still may know about the other's project closely. This is actually an opportunity for students to have a wider scope of knowledge, not only one small part.

Then, as the sensor is fabricated, it is essential to have a test system to provide proper environment for the sensor to start to react. Having a prototype of a process environment has lead to the extension of the initial idea, which is to turn the sampling process into a test system for monthly checking and maintenance purposes. And what is more interesting is that the test system is actually a humidity control chamber, which is needed in so many applications today in various industries.

1.2.2 Significance of the Project

Reviewing back the title, it may sound simple, but the test system can actually offer so many advantages. As figured by researches and some readings, the applications include those in food industry, semiconductor and pharmaceutical & biotechnology. All will need a standard level of humidity, just the right job for the sensor test system, which can definitely act as a humidity control chamber Besides the primary function to provide a real process environment for bench calibration purposes, the test system can be modified into a compact and portable one, so that it can be used for field calibration purposes.

This test system is not only the answer for the question of whether the sensor functions or not, but also to check the quality of the sensor. Initially, when the sensor is new and reliable, one can use the test system to jot down all corresponding outputs

when given different levels of humidity inputs. From time to time, one can use the test system for maintenance and monthly checking purposes, to see whether the sensor will still react similar to results from previous calibration.

Other than that, it is a fact that the sensor will need to be dried off from time to time, after absorbing high level of humidity, so that it will work properly. The test system has special feature for that purpose, which is to only supply dry air to provide humidity as low as possible, to dry off the sensor. User can calibrate the sensor afterwards, by choosing other selection of humidity levels.

Besides testing the humidity sensors, the test system also can be used for other applications which apply humidity concepts, for examples, to measure charge dissipation and capacitance loading capabilities of materials. This is due to the fact that the ability of materials to dissipate static electricity quickly, as needed if static risks and problems are to be controlled, can depend strongly on ambient humidity. Similar with the capacitance loading experienced by charge on the surface of materials, humidity is one of the affecting factors. Studies for this purpose can be done using the test system which provides different levels of humidity for samples experimenting and observation.

Then, acting as a humidity control chamber, it has been essential nowadays for many applications, such as below;

- **Pharmaceutical & Biotechnology**—Stability testing; shelf-life studies; packaging development; photostability testing
- **Semiconductor**—Mini-environment process conditioning; testing and packaging
- **Paper & Pulp**—Conditioning; product storage; box testing
- **Electronics**—Static electricity control in production, testing and packaging; Mil-Spec testing
- **Metrology**—Calibrations and calibration laboratories
- **Textile**—Product conditioning; testing labs; product storage; color matching
- **Wood Products**—Physical testing labs; product conditioning

- **Education**—Agricultural engineering; paper & pulp research; textile research; wood products labs
- **Tobacco**—Shelf life and package testing; product testing
- **Food**—Stability testing and shelf-life studies
- **Archival**—Valuable document storage, e.g. Gutenberg Bible, Gettysburg Address
- Monitor indoor humidity for health reasons
- Optimize conditions in a greenhouse or terrarium
- Study transpiration rates of plants by monitoring relative humidity in sealed jars containing plants

The project should be different from others in the market as the idea of connecting overall system would come from own idea, which make it unique. The most important things will be the low cost, and practicality.

Last but not least, by having the test system, future students can always use it to test and attune their humidity sensors or any other applications which involve the humidity measurement in future. It will save time, as to create such system is not as simple as it may seems. There are many factors to consider, with various consequences to think of. It would be easier if there is already one sensor test system which can also act as the humidity control chamber.

1.3 Objective and Scope of Study

In any project, objectives have to be clearly identified so that targets can be set and achieved by the end of the given period. As for this project, the objectives are;

- To develop a humidity control chamber that can act as the process environment to test the fabricated humidity sensor.
- To have a complete humidity sensor test system that can provide different levels of humidity for test purposes.
- To have a portable test system so that it can be used for field calibration, instead of bench calibration purposes; for monthly checking and maintenance.
- To have a working prototype so that anyone can use the system in any

projects involving humidity measurements in the future.

- To investigate and produce a set of standards, justifying relationship between certain levels of humidity and expected responses from sensor.

As for the scope of study, few areas have been identified in order for the project to be successfully completed by the end of the two-semester period. They are;

- The basic humidity concepts
- Standard responses from fabricated sensor to certain levels of humidity
- The mechanical parts of the system
 - Tubing system
 - Valves system
 - Chamber
 - Water bubbler/heating system
- The PIC microcontroller
- The controller circuit – PCB design
- User interfaces
- Power Supply

All of these studies will be done within the duration given. At the end of the Final Year Project period, there should be a working prototype produced.

CHAPTER 2

LITERATURE REVIEW/THEORY

Literature review is important in building a strong foundation before the project can be continued further. Along the way, a few important topics have been studied. Further researches have been done throughout the two allocated semesters in order to gain more knowledge on issues related to the project.

2.1 Basic Concept of Humidity Measurement

Basically, the term 'humidity' refers to water vapour, i.e., a gas, which is water in gaseous form. It is actually different from the term 'moisture' which refers to water in liquid form which may be present in solid materials or liquids. Humidity is present everywhere in the earth's atmosphere. Even in extremely dry areas and in boil-off from liquefied gases, there are traces of water vapour which in some applications could actually cause problems. The measurement of this humidity is more difficult than most of other properties such as flow, temperature, level, and pressure.

Vapour pressure is the part of the total pressure that is contributed by the water vapour. It is expressed in units of pressure, i.e., in Pascals (Pa), millibars (mbar), or even psi (gage or absolute). Total pressure of a gas mixture is equal to the sum of the partial pressures each constituent gas would exert, were it to occupy the same total volume, according to Dalton's Law. Like other gases, water vapour can be considered to behave as an ideal gas, except near saturation. An empty space in equilibrium with a flat water (or ice) surface can hold a well-defined maximum quantity of water vapour at a given temperature.

Relative humidity is the ratio of the actual vapour pressure and the saturation vapour pressure at the prevailing temperature. It is usually expressed as a percentage. Since

the maximum water vapour pressure depends on temperature, the relative humidity also depends, at given water content, on temperature. At constant temperature and given water content, the RH is, according to the equation for P mentioned above, dependent on total pressure.

2.2 Relative Humidity Sensor

For humidity sensor, HIH-3610-01 from Honeywell has been chosen. This is based on few special features that it has, which actually are giving more advantages to the project. These features include the linear voltage output vs. %RH relationship which has made it easier to calibrate and measure different humidity levels, plus its low power design, high accuracy, fast response time and stable performance.

Direct input to a controller or other device is made possible by this sensor's linear voltage output. With a typical current draw of only 200 μA , the HIH-3610 Series is ideally suited for low drain, battery operated systems. Individual sensor calibration data is available for reference. Available in two lead spacing configurations, the RH sensor is a laser trimmed thermoset polymer capacitive sensing element with on-chip integrated signal conditioning. The sensing element multilayer construction provides excellent resistance to application hazards such as wetting, dust, dirt, oils, and common environmental chemicals. The relationship of humidity levels and sensor output voltage will be given by equation below;

$$\mathbf{V\ out = V\ supply (0.0062 (\%RH) + 0.16),\ typical\ at\ 25\ degC} \quad (1)$$

2.3 Temperature Sensor

LM35DZ has been chosen to be used in the project for temperature monitoring process. This LM35 series are included in the precision integrated-circuit temperature sensors group. The output of this sensor is linearly proportional to temperature in degree Celsius. The advantage of this sensor would be that the user is not required to subtract a large constant voltage from its output to obtain convenient centigrade scaling. The output conversion would be 10mV per Celsius, in the range of 0 to 100⁰C.

2.4 PIC 16F877 Microcontroller

After comparing the PIC to PLC, it has been decided to use the PIC Microcontroller system in controlling the whole system. A PIC seems as if it could easily take the place of a PLC for an application that doesn't require the flexibility PLC's offer, like a project that can be developed once and recreated on a large scale. Industries usually use PLCs for one time projects or when they do not want to maintain the electronics. Picks are used when the project is large and there will be a cost savings or when they want to sell the electronics.

For the test system, PIC16F877 has been chosen as the controller. This PIC16F877 has 5 digital I/O ports (A-E) each between 3 and 8 bits wide. Each port is mapped into the register space, and may be read and written to like any other register. The circuitry is such that it is not possible to physically input to and output from a particular pin simultaneously. For most ports, the I/O pins direction (input or output) is controlled by the data direction register, called the TRIS register. TRIS<x> controls the direction of PORT<x>. A '1' in the TRIS bit corresponds to that pin being an input, while a '0' corresponds to that pin being an output. An easy way to remember is that a '1' looks like an I (input) and a '0' looks like an O (output) [2].

The PORT register is the latch for the data to be output. When the PORT is read, the device reads the levels present on the I/O pins (not the latch). This means that care should be taken with read-modify-write commands on the ports and changing the direction of a pin from an input to an output. The pins on the PIC16F877 are multiplexed so that one of several functions may be selected (e.g. pin 2 may be used as either bit 0 of I/O port A, or as channel 0 of the A/D converter). The TRIS registers control the direction of the port pins, even when they are being used as analog inputs [2].

The user must ensure the TRIS bits are maintained set when using the pins as analog inputs. The A/D allows conversion of an analog input signal to a corresponding 8-bit digital number. The output of the analog sample and hold is the input into the converter, which generates the result via successive approximation. The analog reference voltage is software selectable to either the positive supply voltage (5V) [2].

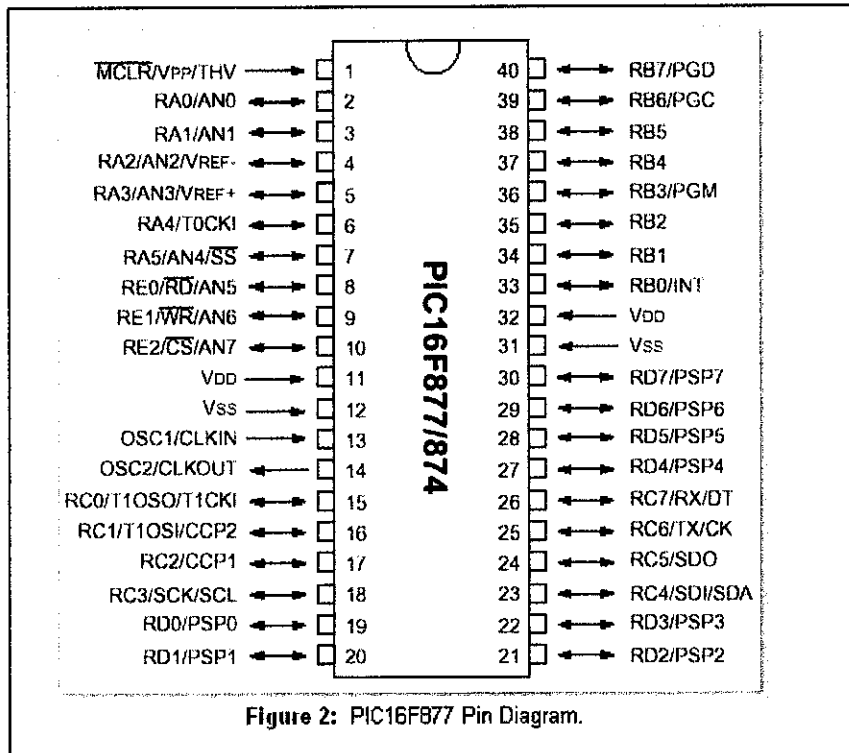

Figure 1 40-Pins PIC 16F877 [2]

2.5 System Controller Circuit

The PIC controller circuit is designed based on the research study from the internet, and also some guidance obtained from past final year projects.

2.5.1 PIC Controller Circuit

As PIC is used as the controller for the overall test system, the ports have been defined to different tasks. The input sensors will be determined by Port A. Port B is assigned for LCD connections, while Port D is for keypad. Finally, Port E is determined to be the one controlling the output valve. The basic connection of PIC16F877 which consists of the PIC itself, power supply, and also clock, is shown by Figure 2 below;

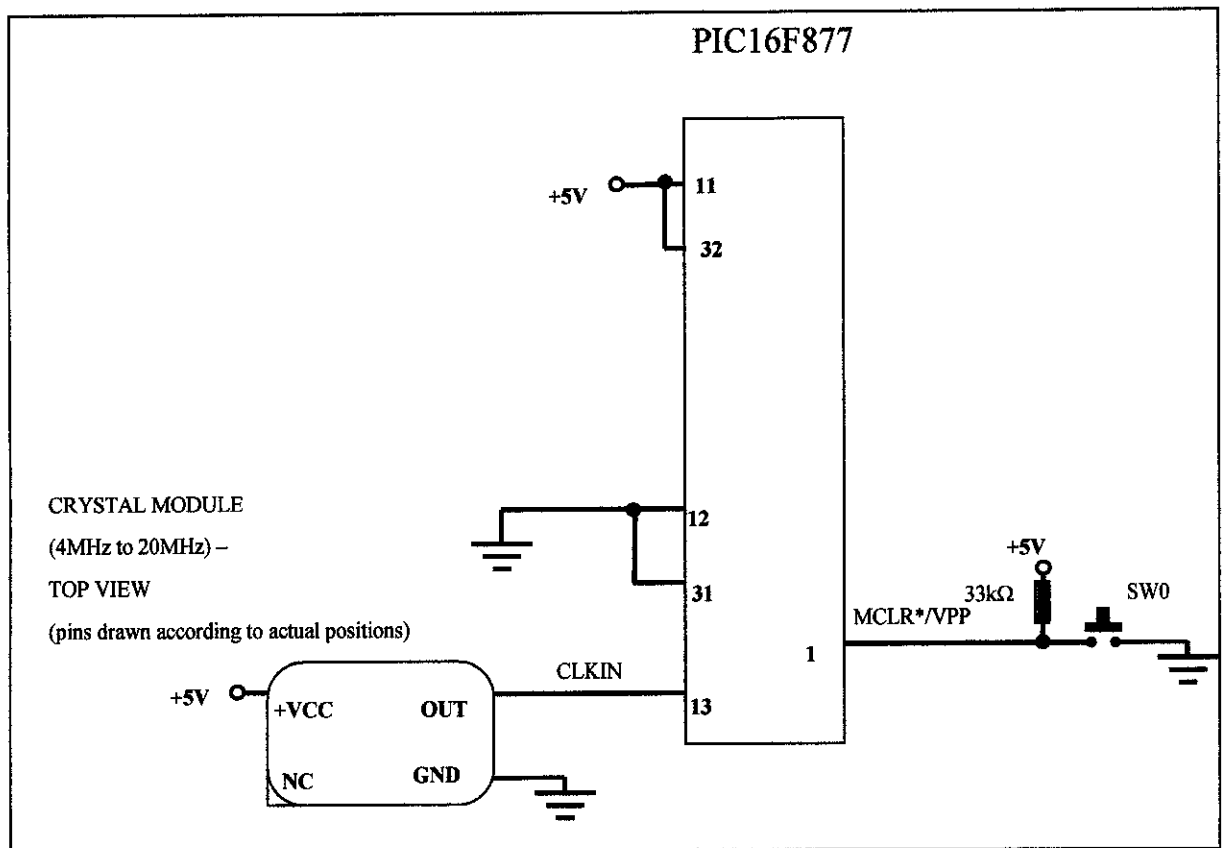

Figure 2 PIC 16F877 Pin Connections[4]

Pin 1 is actually a reset pin. For example, if the PIC has been programmed to work in such a way, the user can always reset everything back to its initial condition. The program will be re-started from the beginning. Pin 13 is important as every PIC needs to be connected to a clock. A crystal module clock can be used for this type of PIC, at the range from 4MHz to 20MHz. as for the test system, a 4 MHz crystal clock has been chosen, as the project does not require too high speed of operation.

Moving on to the connections of the LCD Display, there are two kinds of LCD Display available in UTP's store, either it is a one or two lines display. The one that is used in this project will be the 2x20 (two line, 20 character each) LCD Display, as there will be a lot of information to be displayed. The connections will be shown by Figure 3 as in the next page.

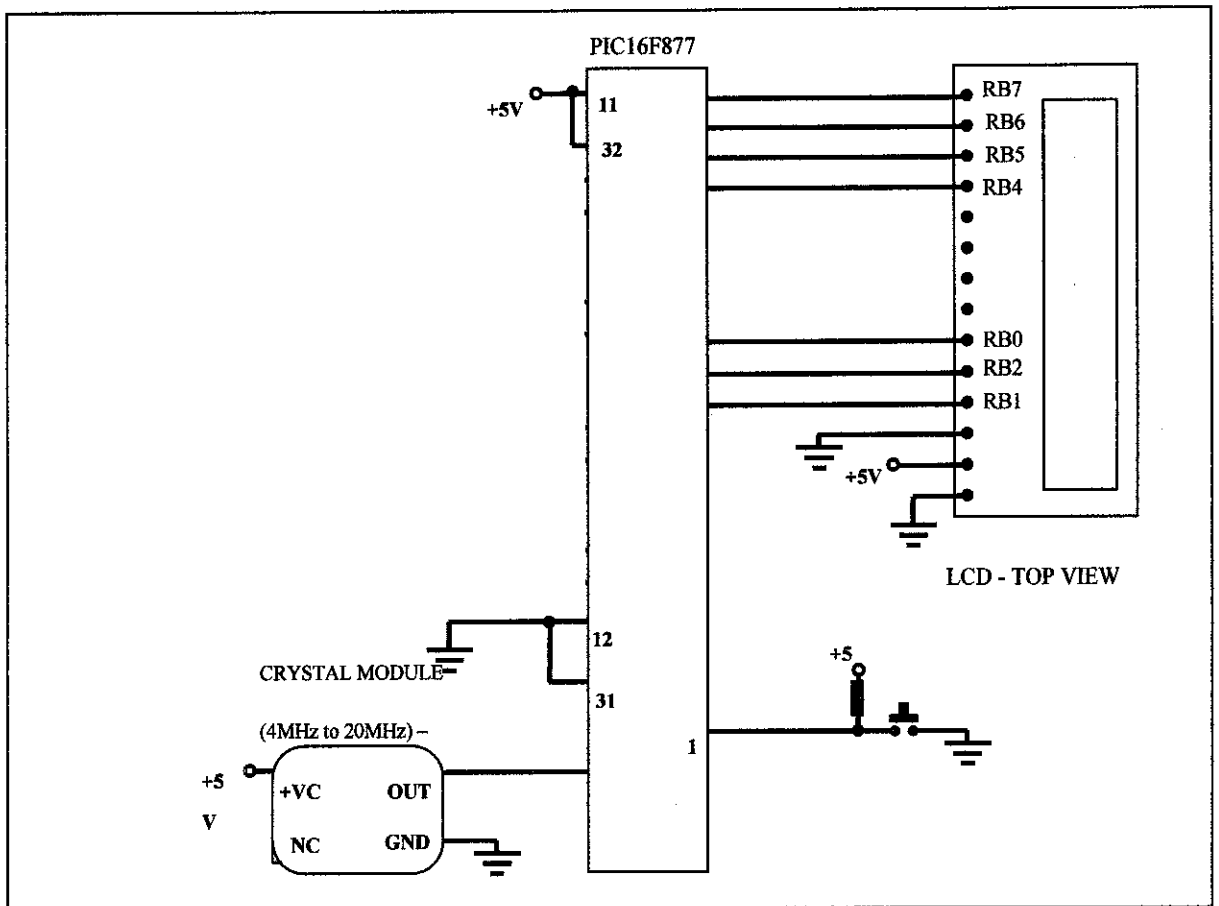

Figure 3 PIC 16F877 LCD Display Connections [4]

As for the keypad connection, this electronics keypad is actually built out of four columns and four rows. The basic connection taken from the internet will be as below. However, for the test system, as programmed, the keypad will be connected to Port D instead of Port B as shown below, to give way to the LCD connections.

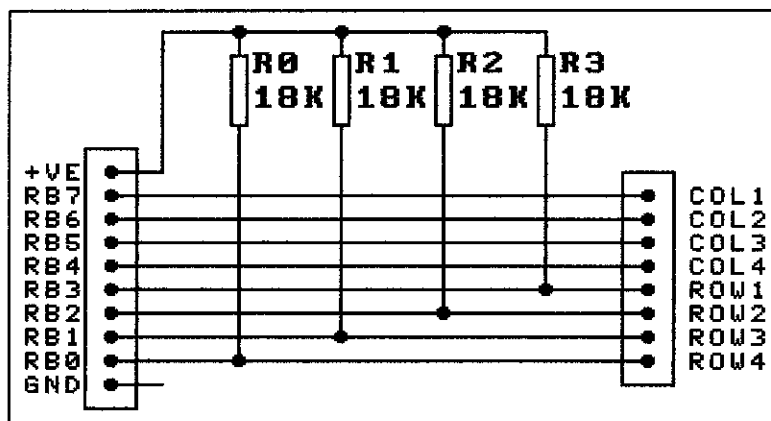

Figure 4 PIC 16F877 4x4 Keypad Connections[6]

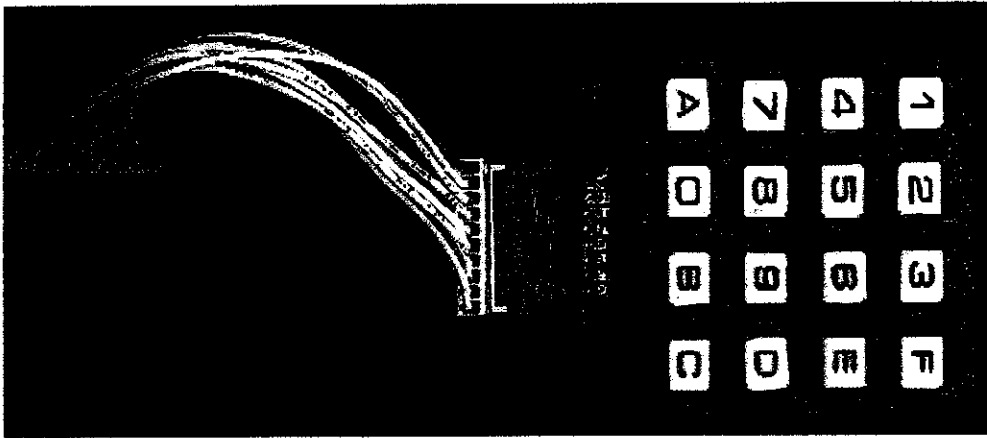

Figure 5 PIC 16F877 4x4 Keypad [6]

2.5.2 The Valve Transistor Switch

Ideas have been generated on how to control the valve, as the output of the PIC would be either 0 or 5V, when the valve requires 24V to turn on. The initial ideas were to have an amplifier, perhaps using the operational amplifier to boost up the output voltage from the PIC or to regulate it by using the voltage regulator. Only then it is found that the easiest way is to use a transistor as a switch. In this case, an NPN transistor has been chosen.

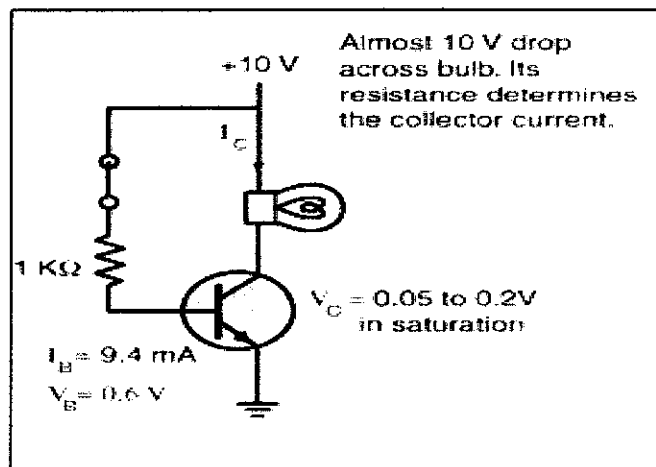

Figure 6 An example of using transistor as switch

The base resistor is chosen small enough so that the base current drives the transistor into saturation. In the above example the mechanical switch is used to produce the base current to close the transistor switch to show the principles. In practice, any voltage on the base sufficient to drive the transistor to saturation will close the switch and light the bulb; in this case, it would be the output voltage from the PIC microcontroller. This transistor switch has been tested and found to be working well.

Other than that, this transistor can act as a current amplifier too. The collector current which will flow through load can be controlled by the base current. A bipolar junction transistor consists of three regions of doped semiconductors. A small current in the center or base region can be used to control a larger current flowing between the end regions (emitter and collector). The device can be characterized as a current amplifier, having many applications for amplification and switching [5].

2.5.3 Voltage Regulator Circuit

As the PIC only needs about 5V to start operating, while the valve need 12V to turn on, a voltage regulator circuit has been constructed and tested. A voltage regulator has been used with a heat sink attached to it to avoid overheat condition. This 5V will be supplied to the PIC and also the two sensors. Batteries will be used so that the system can be portable. An alkaline 12V battery will be connected to supply the whole system. This may change according to the requirement of the solenoid valve used in the project.

CHAPTER 3

METHODOLOGY/PROJECT WORK

In order to ensure the smoothness of the project completion work, all steps and procedures to be taken have to be thoroughly clarified. This methodology section will briefly show the pre-determined track.

3.1 Procedure Identification

Figure below shows the main flow chart of project works to be followed.

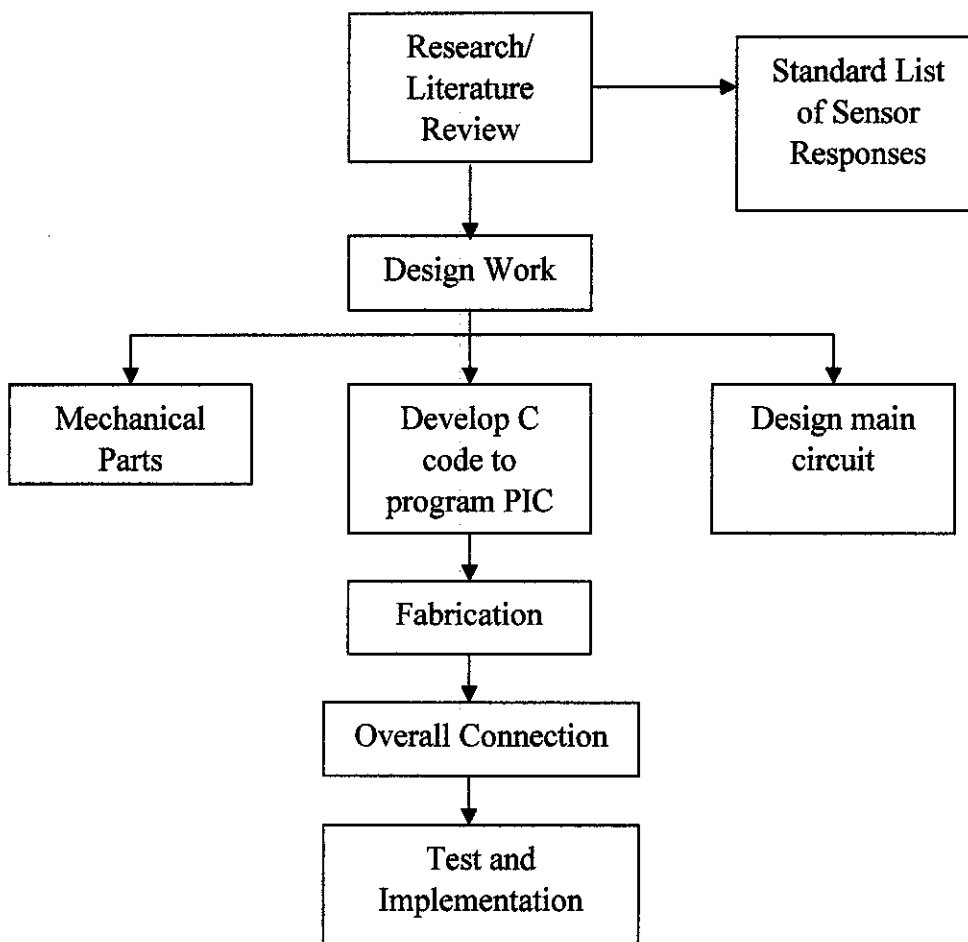

Figure 7 Main Methodology Flow Chart

Figure 7 only shows the main route which has been taken in completing the project. Gantt charts (Appendix A) for both semesters have been created for more systematic project planning. These Gantt charts list all related work according to the main steps shown earlier. Further explanation for each part will be written in following sub-topics.

3.1.1 Mechanical Parts

The mechanical parts will consist of four main parts; the tubing system, valve system, chamber and the water bubbling system. Research and literature reviews are done for every part as each is important. Only then the design work is started separately. As designed, all needed equipments and materials are obtained from laboratories or purchased from reliable suppliers before any experiments or fabrication work can be done. After few testing and observation, and confirmation that each part is working properly, overall connection is done.

3.1.2 Main Circuit

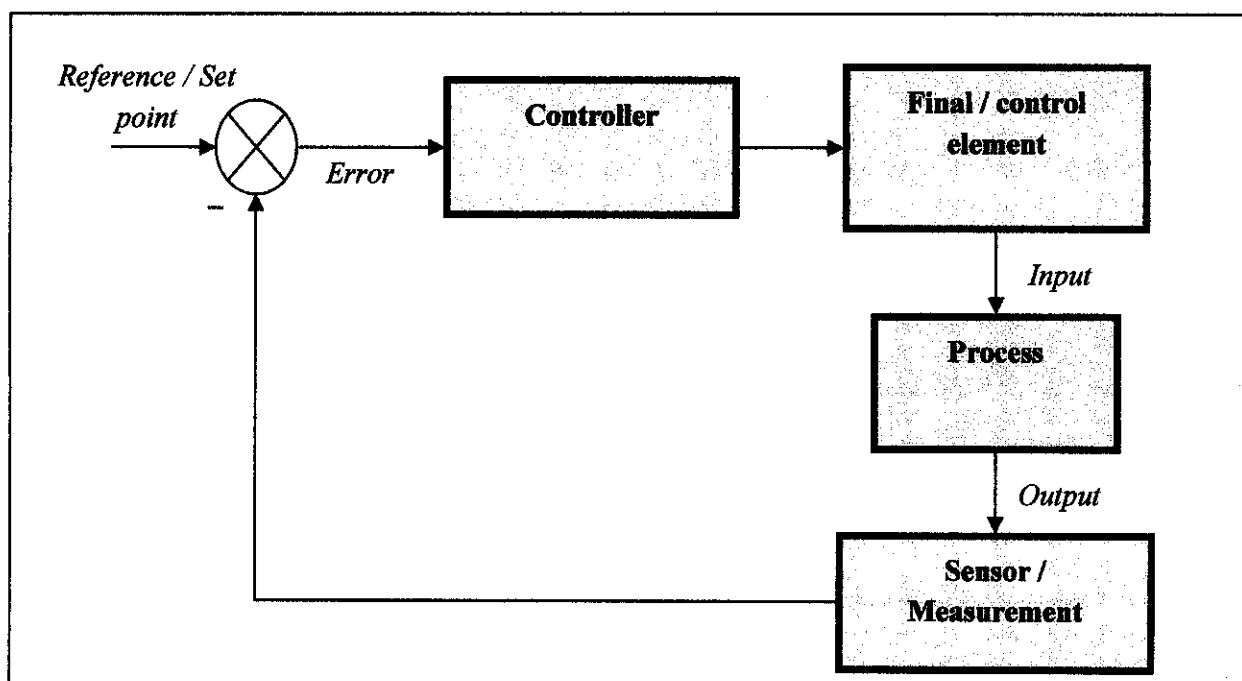

Figure 8 Feedback Control Diagram

The basic concept of the overall system can be shown by Figure 8. As for this project, it can be said that the controller will be the PIC microcontroller, which will run the final control element, in this case the valve. By controlling the valve, this will definitely help in providing humidity to the requested user level. As the process of providing humidity at different levels goes on, the output of this will of course affect the humidity sensor as the measurement element. The temperature sensor will only be used for monitoring purposes. The set point for the test system will be determined by the users.

Based on the scenario above, a good controller circuit has to be designed. Research studies are done in order to get similar circuit from the web to control all mechanical parts and link them to the PIC microcontroller. The input to PIC will be from the relative humidity sensor located in the chamber, and the output from the PIC will control the circuit which will power up the connected solenoid valve as the final controlled elements. Testing and troubleshooting is done as soon as the whole system is connected together. Finally, at the end of the Final Year Project period, this main circuit will be installed and soldered into PCB, for better finishing, stability and longer lifespan.

3.1.3 PIC Microcontroller

The first step is obviously choosing the right model of the PIC which is going to be used and do some research on it. For the controller system, it is essential to determine the physical sequence of the overall system, so that one will know what should be set into the microcontroller. As for setting the controller for the whole system, the PIC has to be programmed first.

The flow chart will be as shown by Figure 9 in the next page.

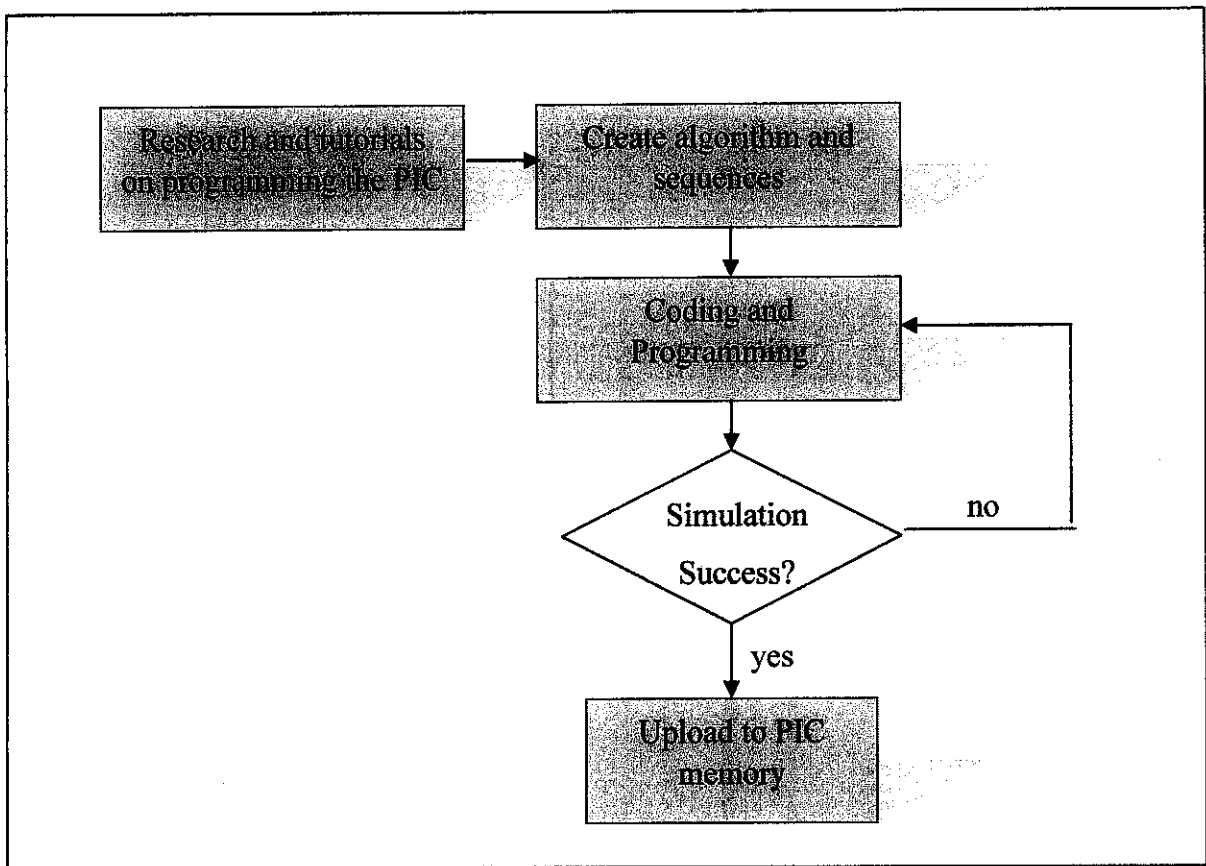

Figure 9 PIC and Main Circuit Development

An algorithm has been created to make it easier to write C program for the system. It has been designed for the system to stay in the loop in maintaining the humidity level inside the chamber as requested by users until the reset button is pressed. The system will start to work again if there is any input keyed in by users. ADC Value will be calculated by using the formula below;

$$V_{in} = \frac{V_{fullscale} \times Adc \text{ value}}{(2^n - 1)} \quad (2)$$

Where V_{in} = Sensor output voltage

$V_{fullscale}$ = 5V

$2^n - 1 = 256 - 1 = 255$, for 8 bit A/D

The flow is shown by Figure 10 the next page.

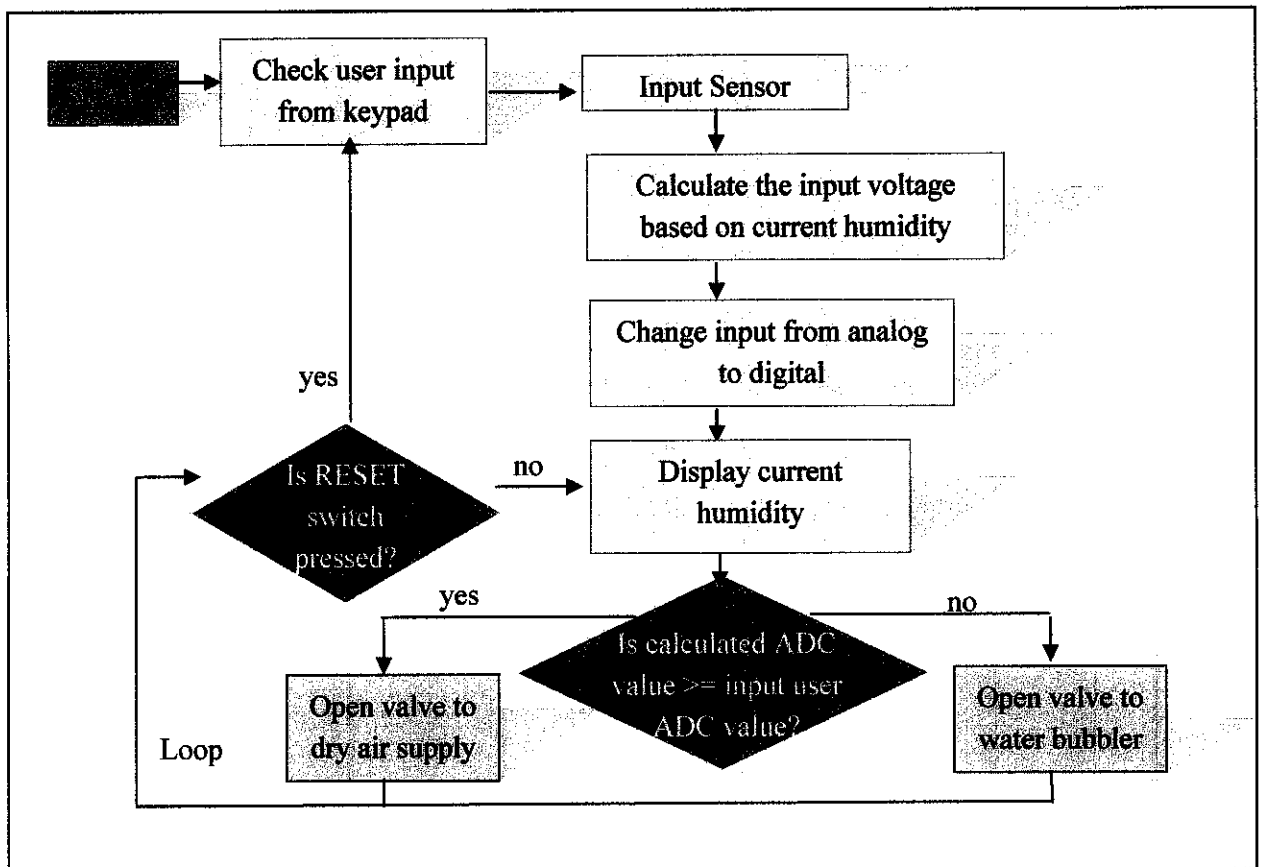

Figure 10 PIC and Main Circuit Development

3.2 Tools / Equipments

Some tools and equipments have been identified for the use in this project. Changes are made along the way as new findings are obtained from time to time. The tools are divided into sub-groups as below;

3.2.1 List of hardware equipment

- ⊕ Chamber
- ⊕ Solenoid Valves
- ⊕ Tubing
- ⊕ Tube Fittings
- ⊕ Standard Humidity Sensor
- ⊕ Temperature Sensor

3.2.2 *List of testing equipments*

- ⊕ DC power supply
- ⊕ Multimeter
- ⊕ Digital thermometer
- ⊕ Hygrometer

3.2.3 *List of Software*

- ⊕ PSPICE (Circuit Simulation)
- ⊕ EAGLE 4.13 (PCB Design)
- ⊕ CCS Compiler (PIC programming)
- ⊕ Warp 13 (PIC Uploader)

CHAPTER 4

RESULTS AND DISCUSSION

4.1 Mechanical Parts

To start fabricating the test system, drawings are made, initially sketched by hand before finally drawn using computer. The system is made out of a combination of a water bubbler system, test chamber, tubing and valve system as planned in the initial stage. At first, as for the chamber, the plan was to make a chamber using Perspex available in store. After cutting the Perspex into appropriate-sized pieces, a slight change has been made as a more suitable container is found.

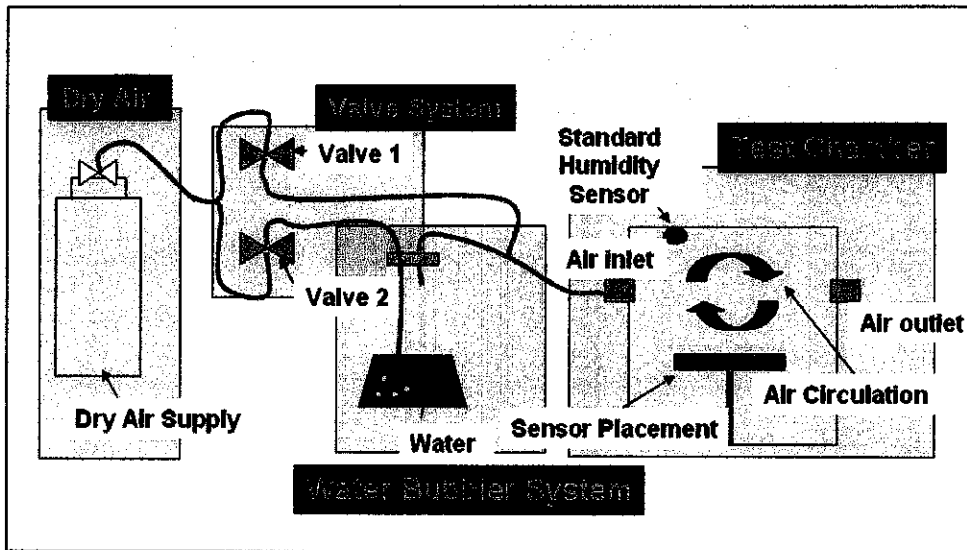

Figure 11 System Overall Block Diagram

It is actually a fresh vacuum container, designed for the purpose of storing any food with protection from dampness and decay. This is done by pumping out all the air in the container to create vacuum in it. The lid of the container has been attached to an air pump holder for this purpose. This vacuum condition can be useful for the sensor test system in achieving lower initial percent of relative humidity faster.

The container is chosen in a medium size, which has a total volume less than the test chamber used for experiments in the previous semester. As experiments are done, it seems like the initial plan can not be used. The pump could not really function because of the holes created for the air circulation. But still, the test chamber can be used to complete the overall test system.

As for the water bubbler system, a small container has been chosen. The design of the container is found to be suitable for the system. It is in a medium size, more or less a little bit smaller than the test chamber. Then, the tubing system is completed by having two tube fittings attached to the test chamber, and a tee junction that connects both routes; the one that go through the water bubbler system, or directly to test chamber, to the dry air supply. PTFE tape is used to make sure that there is no leak. Holes have been drilled to both containers where appropriate, according to the drawings.

The test system has been designed in such a way that user can see every part inside it. For this purpose, here comes the use of this Perspex outer casing. From the front view, user can see the display, and can communicate with the system by using the provided keypad. From the sides, one can see the operation of the water bubbler system, and also the test chamber. Finally, one can also analyze the overall controller circuit from the rear view. The size of the whole system is designed to be appropriate enough for the system to be portable and easy to carry.

4.2 Controller Circuit

The controller circuit consists of several parts; the PIC microcontroller circuit, the valve transistor switching circuit, and the voltage regulator circuit. PIC microcontroller will be the heart of the whole controller circuit where it regulates the overall process according to set points given. The input would be from the humidity sensor for humidity control and also temperature sensor for monitoring purpose. The outputs are the solenoid valves and LCD, both controlled by PIC.

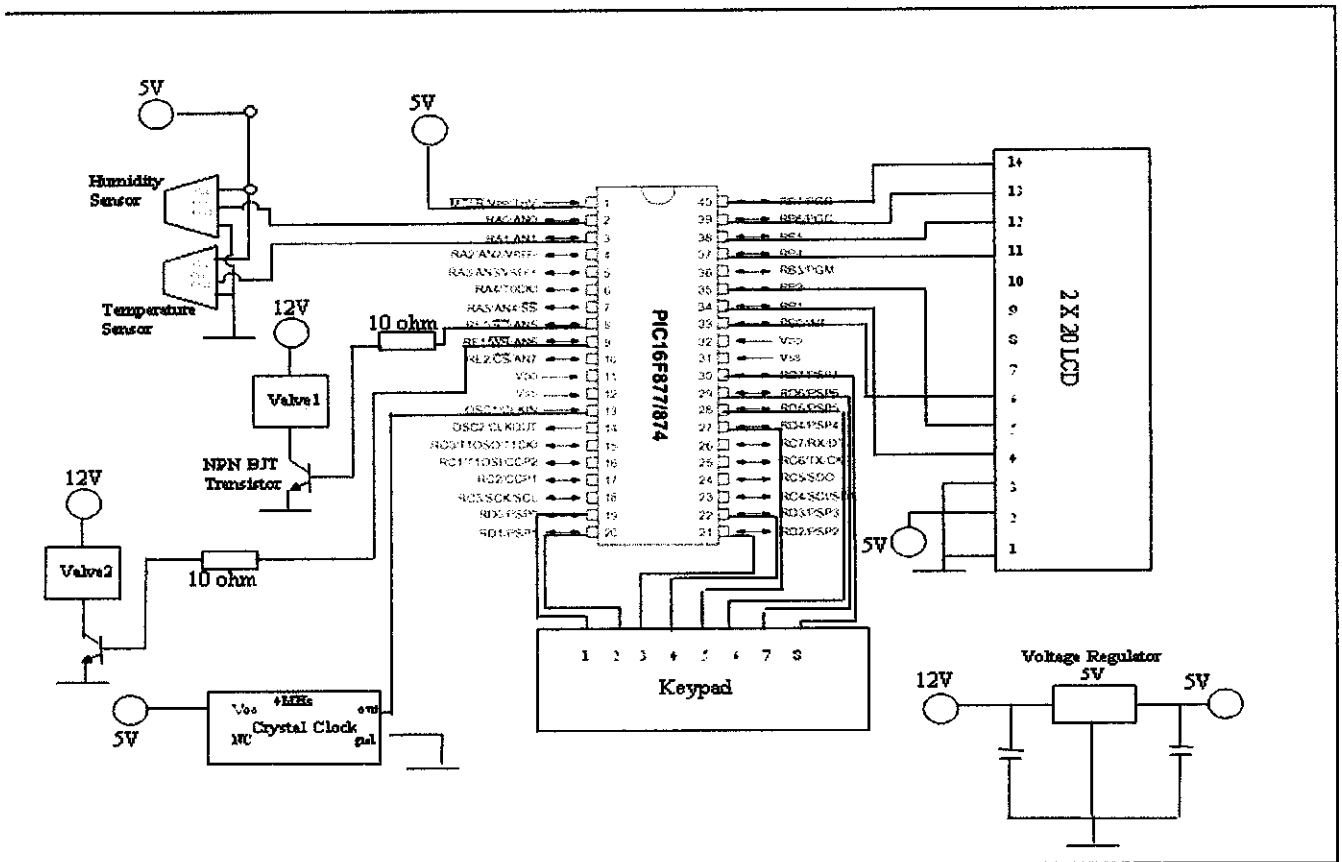

Figure 12 Overall Controller Circuit

4.2.1 Construction of PIC Controller Circuit

As researches are done, and the overall PIC schematic diagram is completed, all needed components are then immediately taken from UTP store in order to construct the circuit. The first attempt is to use the normal breadboard for testing purpose. All components are put onto the board temporarily to see if the desired results can actually come out. It is then when it is figured out that the PIC itself was not stable, resulting in unstable output, or worse, contributing to no output at all.

Troubleshooting is made, as the LCD and keypad are taken from the store. Both components are soldered on small pieces of Vera board before connected to the PIC main circuit on the breadboard. The objective was actually to make it easier to connect, as both are already connected to the rainbow wire. As it is quite difficult to solder wire directly to the small pins of the components, the Vera board has been taken as a wise solution at that time.

However, as simple program is downloaded into the PIC for the purpose of testing the circuit, where the program instruction was to only display 'Hello', it seemed like there were some problems with the circuit, as no output was displayed at all. It is believed that two possible reasons could be the connection of the PIC on the breadboard, and also the way of uploading the program onto the PIC.

After ensuring that there was no problem of the way programs are uploaded into the PIC, it is confirmed that there are problems with the connections. To solve this, all components are transferred onto Vera board and soldered accordingly. Digital Multimeter is then used to ensure that all connections are correctly made.

As tested with same 'Hello' program, to one's relief, the LCD Display has finally managed to project out the word. Only then the circuit will be ready for a correctly programmed PIC.

4.2.2 PIC C Program: Compiling, Uploading and Testing

Initially, a program has been created in the previous semester, but has not been tested. However, the program has to be modified to fit in the keypad functions, as previously, the idea was to connect the PIC to five different switches for users to choose from. As the range is widened, a keypad has been used to replace the function of the switches. By this way, users can enter any value that they want, from 0 up to 99%RH.

For a start, the C program is divided into three main parts, the ADC part, display, and last but not least, the keypad. This is done so that it would be much easier to detect any errors, so that troubleshooting can be done immediately. The standard example programs are available; with some modifications, these programs can be very useful. To start the programming process, PICC Compiler is used to compile the programs. This compiler is used to convert the C file into hex file.

In order to compile the C files correctly, one must have correct settings. Any interface C program, which is included in the main program has to be identified its location, saved in the project directory. If not, there might be some errors since the compiler cannot identify certain functions which are actually defined in the interface files. It is shown in Figure 13 as below.

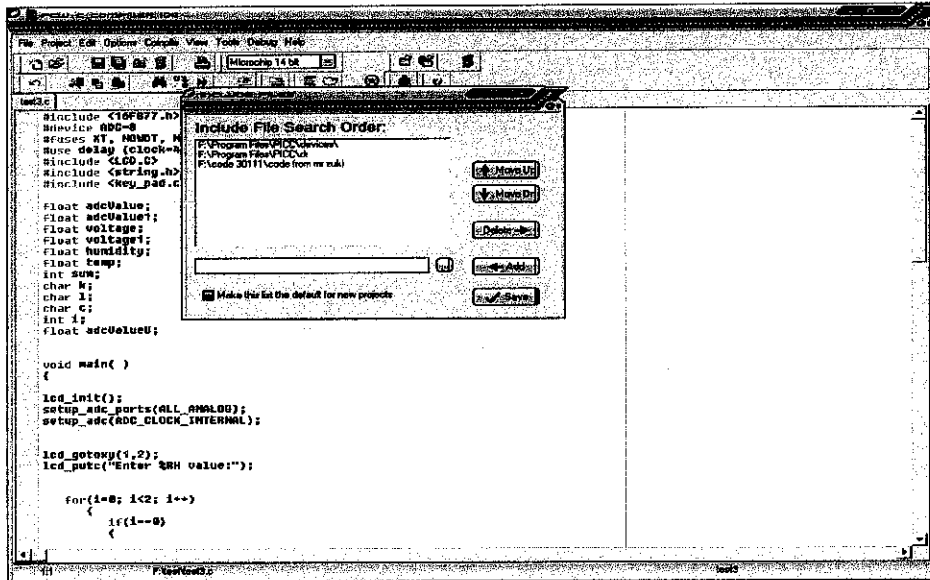

Figure 13 PICC Compiler – Including Files in Directory

After compiling the programs, and successfully having the hex files, the program is then uploaded onto PIC. Initially, a ready-made PIC16F877 testing board has been used. The circuit is there already; users will just have to upload programs for testing. The ADC, LCD and keypad programs are then uploaded separately, and tested one after another. Correct outputs are obtained, showing that there are no problems with the programs, and the equipments (LCD Display and keypad).

Since the complete circuit has been constructed earlier, soldered on Vera board, the programs are then uploaded into the real PIC that will be used in the project. As uploaded, each output will be observed so that programs can be modified accordingly. These programs are uploaded using Warp-13, the PIC16F877 burner.

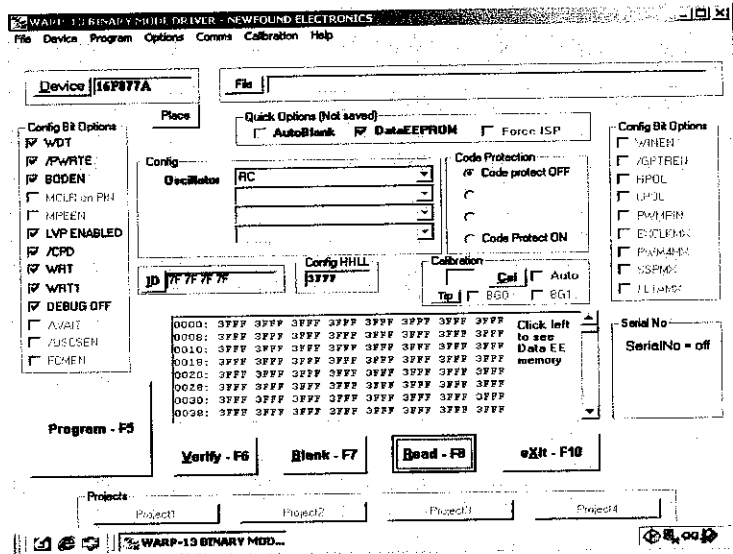

Figure 14 Warp-13 Software

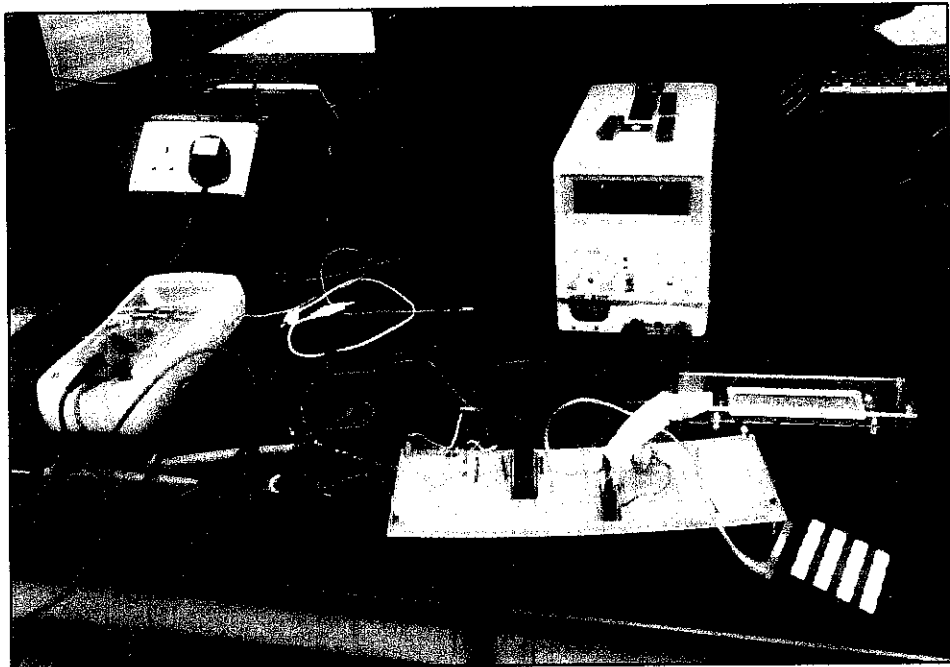

Figure 15 PIC Microcontroller Circuit Testing

Initially, two separate programs have been successfully uploaded to produce outputs as desired. One is made to read the analog inputs, convert to digital, and display both current temperature and humidity readings, and the other program is made to read user input from keypad, and convert it to proper ADC value limits in order to control the valves. At the end of week 3 of the second semester for Final Year Project, finally a correct program which combined both has been successfully uploaded into PIC and tested. The program will be as in Appendix D.

4.2.3 Solenoid Valves: Transistor Switching Circuit

The solenoid valve has a maximum rating of 24V dc, in which it will need as high as 0.57A current. The circuit, as measured, is only capable of supplying about 0.12A. To solve the problem of this limiting current, a simple experiment is done where the valve is directly connected to the power supply to find the minimum voltage that can turn the valve on. From the experiment, the results can be summarized as in Table 1 below;

Table 1 Voltage and Current Ratings for Solenoid Valve

Voltage rating (V)	Current rating (A)
24 (maximum)	0.57
12	0.29
9 (minimum)	0.22

It seems that the minimum voltage that can turn on the valve is about 9V. This voltage rating will be used so that it would be easier to provide the minimum current rating. As the valve is connected to the PIC controller circuit, an ammeter has been put in series with the valve to check the current supplied. It can be concluded that the critical part in the controller circuit that needs some modification is the transistor, which acts as both switch and current amplifier component.

The initial transistor used is the 2N3904 NPN General Purpose Amplifier. The device is designed as a general purpose amplifier and switch. The maximum collector current rating for this type of transistor is 200mA. The connection of the transistor is shown by Figure 16 in the next page.

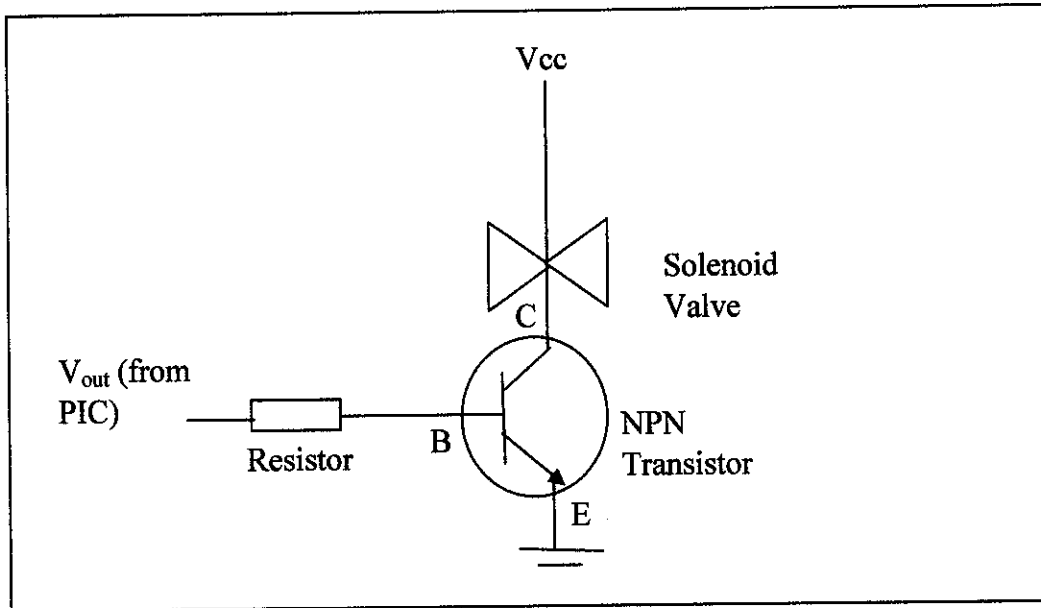

Figure 16 Transistor Switching Amplifier Circuit

As experimented with two different resistors, the results can be summarized as in Table 2 below.

Table 2 Observations for 2N3904 NPN General Purpose Transistor (Power Supply=9V)

R, Resistors (Ohm)	V _{CE} (V)	V _{CB} (V)	V _{EB} (V)	Calculated I _B (A)	Measured I _C (A)
200	3.6	2.6	0.9	22m	120m
100				6m	150m

The I_B is obtained by calculation as below;

$$I_B = (V_{out} \text{ (from PIC)} - V_{BE}) / R \quad \text{where } V_{out} \text{ is about } 2.1V \quad (3)$$

It can be concluded that in order to make the collector current I_C to be higher, the value of the resistor must be reduced accordingly. As the valve need at least 0.22A in order to trigger it, the transistor has to be changed as the present transistor's maximum current rating is only about 0.2A. A 2N4401 NPN Switching Transistor has been chosen for this purpose.

This transistor from Philips has a high current (up to 600mA) feature, which is suitable for the project. Experiments are done immediately to see the effect of this transistor replacement. The calculation of I_B would be the same as the one used previously. The observations are summarized as below.

Table 3 Observations for 2N4401 NPN Switching Transistor (Power Supply=9V)

R, Resistors (Ohm)	V_{CE} (V)	V_{CB} (V)	V_{EB} (V)	Calculated I_B (A)	Measured I_C (A)
68	0.16	0.68	0.9	16.3m	205m
41				3.41m	206m

It can be seen that as the value of resistor is reduced, the collector current, I_C begins to improve in having a higher value. Only that it is still not enough. More power supply is given then, which is about 12V. The V_{out} from PIC is then measured to be about 1.18V. The result is as in Table 4 below.

Table 4 Observations for 2N4401 NPN Switching Transistor (Power Supply=12V)

R, Resistors (Ohm)	V_{CE} (V)	V_{CB} (V)	V_{EB} (V)	Calculated I_B (A)	Measured I_C (A)
10	0.19	0.69	0.88	30m	275m

By using 10 ohm resistor and 12V power supply, the controller circuit seems to work well for triggering solenoid valve whenever required.

4.3 Overall System: Testing and Troubleshooting

4.3.1 Using Directional Solenoid Valve

Directional valve has been chosen to be used in the project due to its light weight and narrow design. At first, there have been some difficulties and confusion on the application of the directional solenoid valve. Only after some explanation by the supplier of the directional valve, it is figured that the valve could actually be applied to the project. As experiment is done, the valve seems to be working well when tested alone.

Due to this, the overall connection, including the circuit, the chamber, water bubbler system, and the valve are then connected accordingly with proper tubing system. As tested, the air supply will go through a tee junction tube fitting which connects both tubing to the water bubbler system and direct tubing to chamber. As dry air is supplied, it can be seen from the LCD Display that the humidity readings in %RH drop immediately down to about 16 %RH.

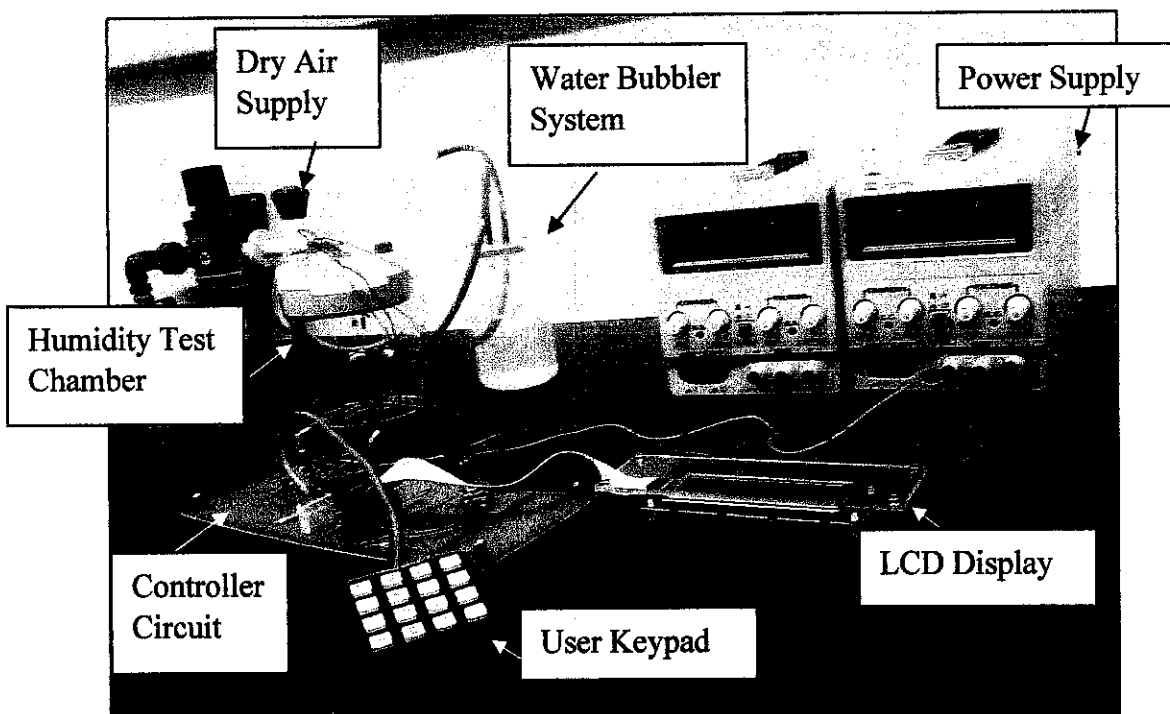

Figure 17 Test System: Testing and Troubleshooting

As observed, the distribution of air supply is not really even; the air tends to go through the tubing directly to the chamber instead of the tubing to the valve. This will result in very little amount of humid air that will flow into the chamber. The proportion of dry air is identified to be quite larger to the humid air; making it hard for the relative humidity inside the chamber to increase, even with humid air flowing in. Lucky enough when setting the user input to be at 17%RH, the humidity inside the chamber is maintained from about 16.9% to 17.2%RH as the valve is controlled well by the PIC program.

When the input is changed to higher relative humidity levels such as 20% or more, the valve will be triggered, but the humidity inside the chamber is observed to stay around 17% to 18%RH and not going to ever reach 20%. This is due to the fact that there is not enough humid air that is flowing into the chamber.

Finding the cause for this problem, the directional valve is observed once again, by testing itself with air supply. As analyzed, the valve needs certain amount of air to actually push the solenoid inside so that the valve will be opened. That is why it needs quite large amount of air for it to open. Looking back at the system, the air supply will meet a tee junction for the two different routes. It is obvious that the air will choose the route without any obstacle instead of going into the route where the air has to push the solenoid in order to get through, as the valve is triggered. It will follow the route where the pressure is lower, unless the dry air route is blocked, only then it will go the other way round.

It can be concluded here that a normal solenoid valve should be used so that the air supply can be distributed evenly between the two routes. This is because a normal solenoid valve will open as soon as it is triggered by electrical signal. It does not depend on the air flow.

4.3.2 Using Normal 24V Solenoid Valve

The directional valve is then changed into a normal solenoid valve. As the valve is tested alone, and is observed to have worked well, the overall connection is done once again for testing and troubleshooting. At first, the air supply is connected to the tee junction, same as before, before connecting the two routes to both chamber and valve. As the air supply is given, and the valve is triggered by sufficient power supply, the air seems to have flowed evenly to both routes. The air pressures at the end of both routes are almost the same, and obviously is enough to create bubbles in the water bubbler system in order to produce adequate humid air for the test system.

As the controller circuit is switched on, the first thing that will be displayed on the LCD screen would be as in Figure 18 below. The program is designed to ask for user input, in order for the controller circuit to start working. As users enter their required value of %RH, the valve will be controlled accordingly. The reset button has to be pressed if the user wants to enter a new value.

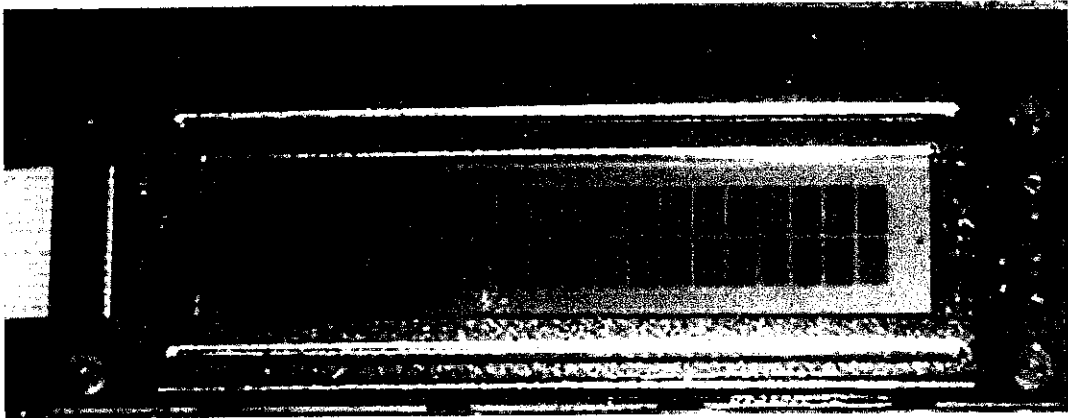

Figure 18 Asking for User Input

The program will read the current humidity once in 2 seconds. The users will get to see the current humidity and temperature on the LCD Display. The required %RH that they have entered earlier can be viewed too so that everyone will know the target of the system at one particular time. As the current humidity is lower than needed, the valve will be opened so that more humid air will be injected into the chamber. As the humidity increases more than the required level, the valve will be shut off, so that only dry air will be supplied into the chamber.

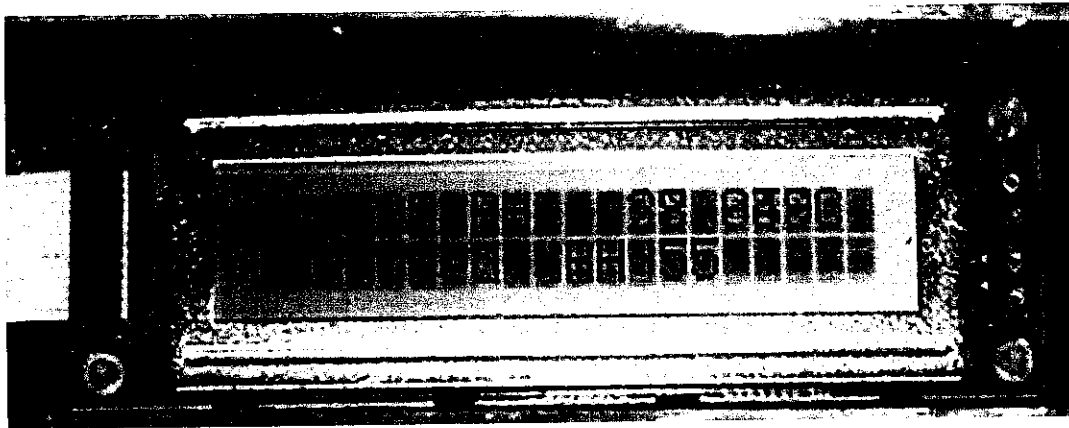

Figure 19 Displaying Current Humidity and Temperature

As the test is done, the output voltage of the humidity sensor has been measured, and plotted against the humidity level displayed. The results are as in Table 5.

Table 5 Checking the Output Voltage against Displayed %RH

Output Voltage, V	%RH
1.03	14.040
1.13	17.200
1.22	22.500
1.37	27.900
1.59	30.230
1.76	31.000
1.90	36.200
2.30	48.390
2.50	54.840
3.23	79.340
3.26	79.360
3.34	81.612

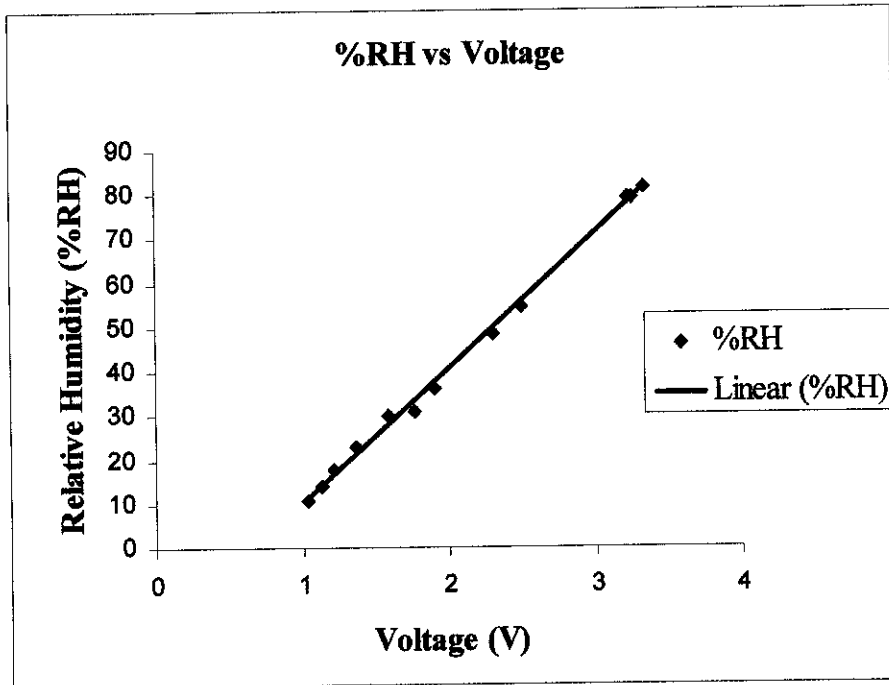

Figure 20 Graph: Humidity Sensor Output Voltage vs. %RH Displayed

As all data recorded during the test run of the project, it seemed that there were slight differences between calculated values and the measured ones due to some errors. This is due to the on-off state system, which obviously does not have a zero error steady state output. The results are listed and compared as in Table 6 below;

Table 6 System Output

	First Trial	Second Trial	Third Trial
%RH required	%RH measured		
10	13-14	15-16	14-15
20	19-26	19-30	19-27
30	26-38	27-38	28-36
40	35-46	37-48	37-48
50	39-52	43-55	46-55
60	52-64	53-62	51-63
70	63-74	63-73	59-71
80	65-110	70-82	70-85
90	70-125	86-94	86-91

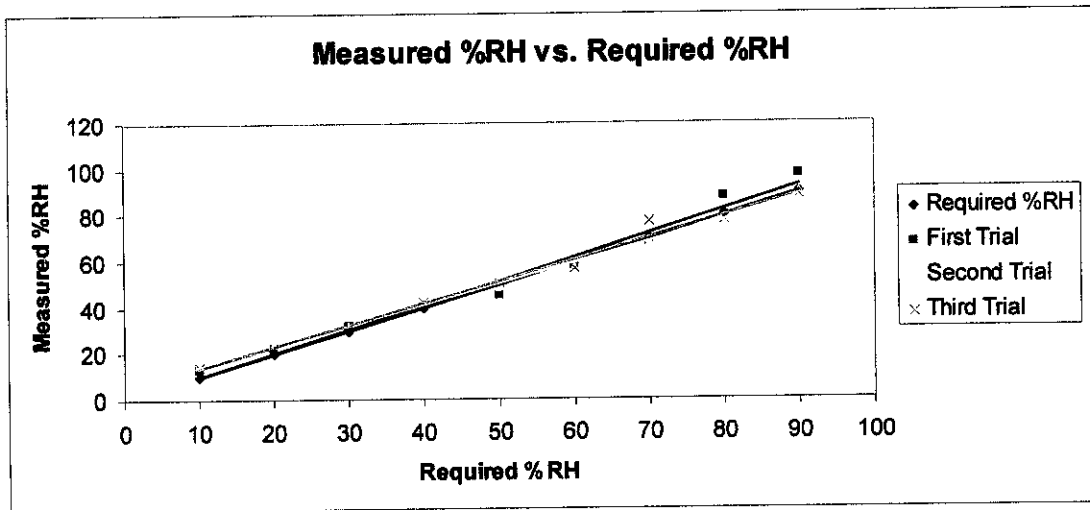

Figure 21 Graph: Measured %RH vs. Required %RH

The first trial has been done using the circuit constructed on Vera Board, while the other two trials are done on the PCB circuit. It can be observed that the system output actually improves for the higher %RH levels, which is from 80%RH and above. For better analysis, the system error has been calculated as below;

Table 7 System Accuracy

	Error (Average)			
	First Trial	Second Trial	Third Trial	Average
%RH	6.6	6.6	6.6	6.6
Percentage (%)	16.4	13.1	13.1	13.1

Errors are calculated in two ways; one is in term of +/- %RH value and another one is the average percentage of error. It can be seen that by using PCB, the error is improved to be smaller. Compared to most of existing high-technology humidity control chambers in the market nowadays which have accuracy about 2%RH, this system is actually acceptable and not far behind.

As experiments are done, it is then figured that the settings actually can affect the humidity levels. It can be concluded that the best the test system can do will be according to the settings summarized in Table 8 below. This is done based on the least noise that the system will make, and the suitable pressure for the water bubbler system. Too much pressure could actually make the air circulation in the water bubbler system turbulent, causing water to start entering the outlet tubing to the chamber.

Table 8 System Settings

%RH required	Bubbler position	Pressure (psi)
10	on water surface	2
20		1
30		
40		
50		
60		
70	inside water	2
80		
90		

As experiments are done, it can be observed that the highest value of %RH that the system can provide properly is about 75%RH, while the lowest is about 13%RH. The higher %RH levels from 80%RH and above requires quite some time to actually achieve the set points. As analyzed, it can be observed that the upper limit for each level, from 20% to 90%RH, are indeed very close to the set points, but the lower limit is quite far. This is due to the incompatibility effects of the dry and humid air. It takes longer for humid air to change the humidity level in the chamber than the dry air. Even a little dry air can cause quite obvious changes in humidity levels.

4.4 Prototyping Design

4.4.1 PCB Design and Fabrication

A PCB (Printed Circuit Board) has been designed for better accuracy and stability of the controller circuit. It will look more presentable, and also will be more robust. To design a PCB, few steps have been taken carefully, so that the design will not have any error.

The work of PCB design has been done using the Eagle 4.13 software. To start designing, a new Project Folder has been created. An empty schematic is next created under this project. Only then the overall controller circuit schematic is drawn, and saved. To create an empty board layout under this file, 'File → New → Board' is selected from the corresponding folder. The drawing techniques are a bit different from using PSPICE.

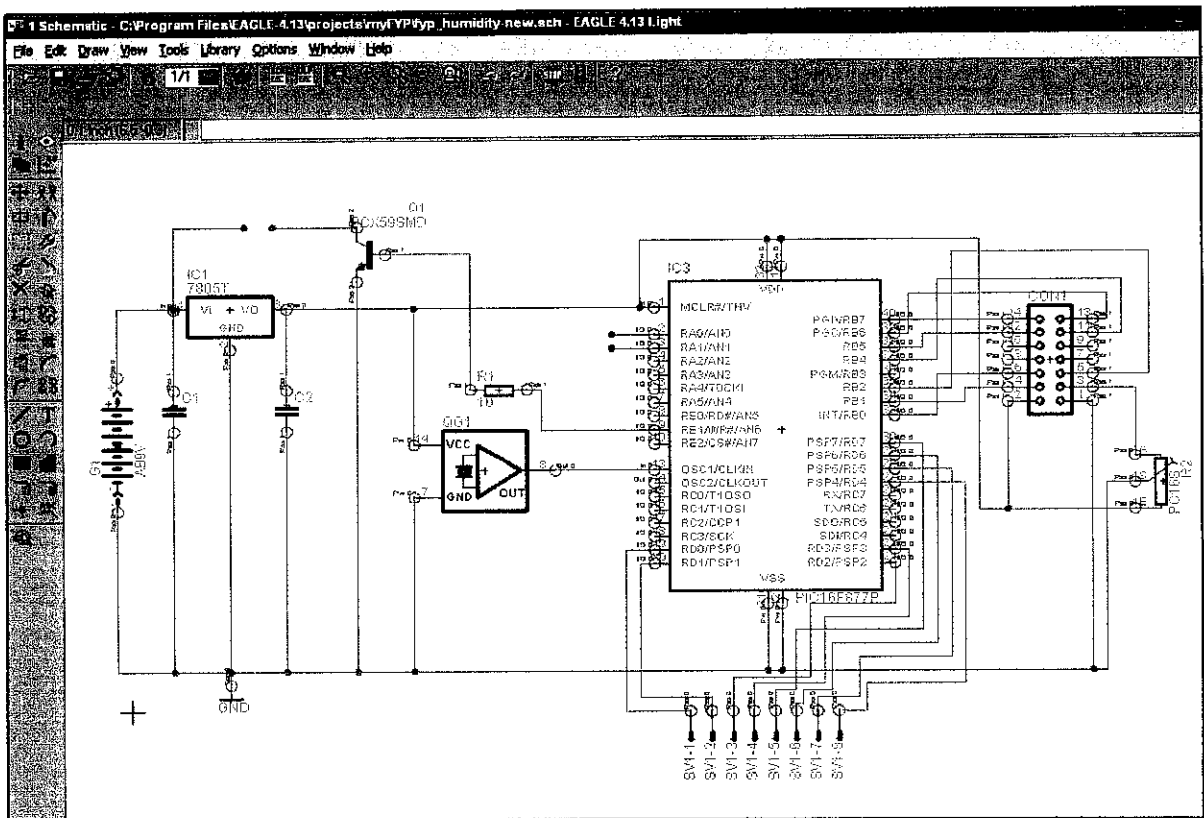

Figure 22 Controller Circuit Schematic Diagram

After the schematic is done without errors, the 'Board' mode is selected. This mode will show the arrangement of all components on PCB. The rule of thumb is actually to make sure that smaller board can be achieved with the correct connection between pins and terminals without any signals to cross each other. An 'auto-routing' function can be used by clicking on 'TOOL → AUTO → OK'.

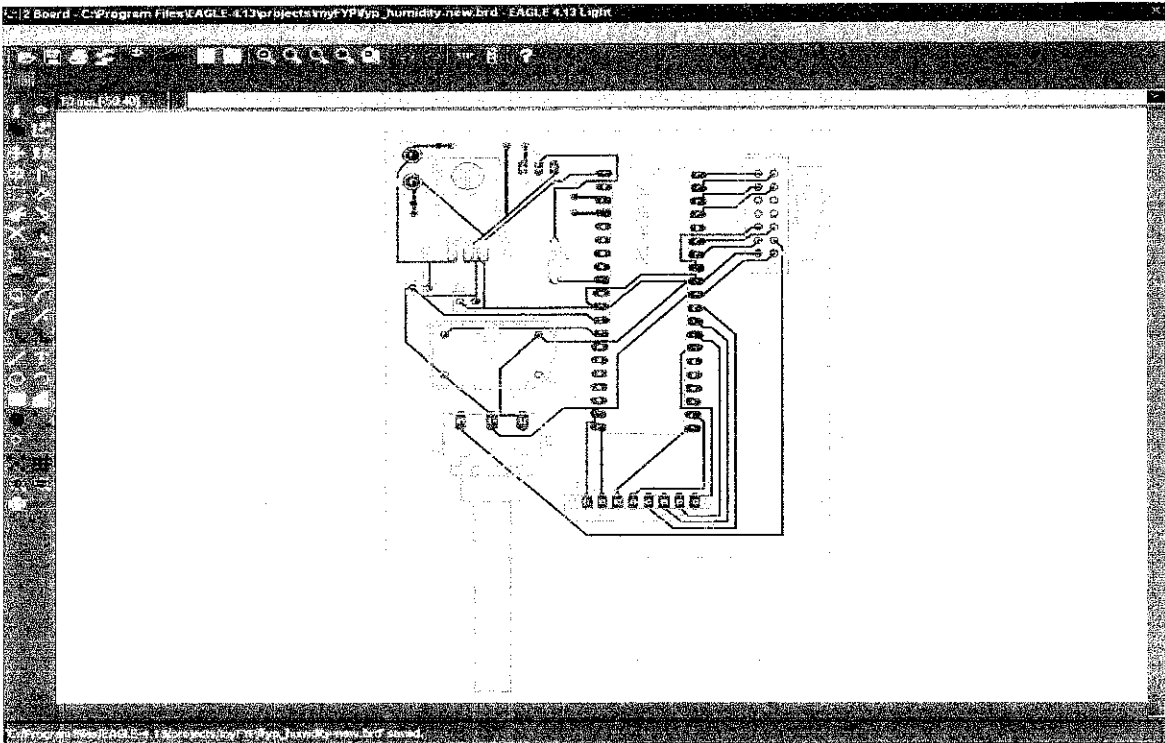

Figure 23 Controller Circuit Board

To change the routes done by the software, the 'EDIT → ROUTE/RIP-UP' is selected to actually rip-up the circuit (scrap the copper lines) and then reroute the circuit. Only when there is no route crossing to be found on the circuit that Gerber files can be extracted from this board design.

To start creating the necessary files for PCB fabrication, the icon CAM (or File → CAM Processor) is chosen. Next is to open the required job (or File → Open → Job) so that one dialog box will appear. '**excellon.cam**' is selected and opened. The Process Job is selected so that ****dri** file can be generated. Only then that '**gerb274x.cam**' file is opened. This will generate 10 files automatically (***.sol**, ***.dri**, ***.gpi..**) which later are saved for PCB fabrication.

As the PCB fabrication is done, appropriate components are then installed and soldered before testing and troubleshooting is done.

4.4.2 Prototyping

A compact and portable system has been designed so that the objective of using the system for monthly checking, calibration and maintenance purposes could be accomplished. As discussed earlier, it has been design to be small in size, but yet include everything together as one, and has a user friendly figure. The prototype has been tested and then proven to be working properly. It is shown in Figures 24, 25, 26 and 27.

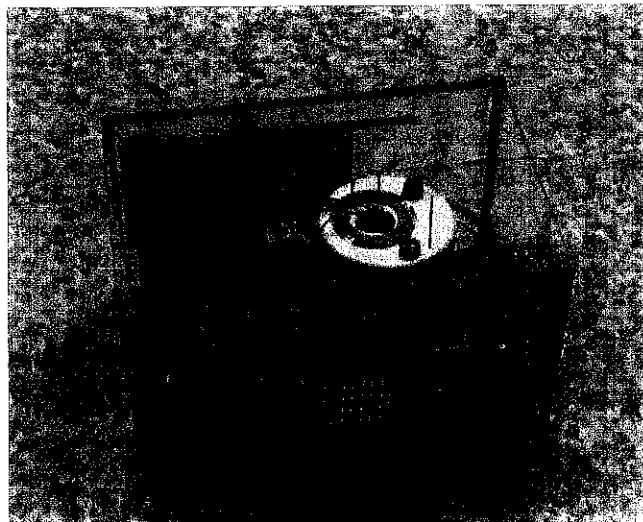

Figure 24 Humidity Control Chamber

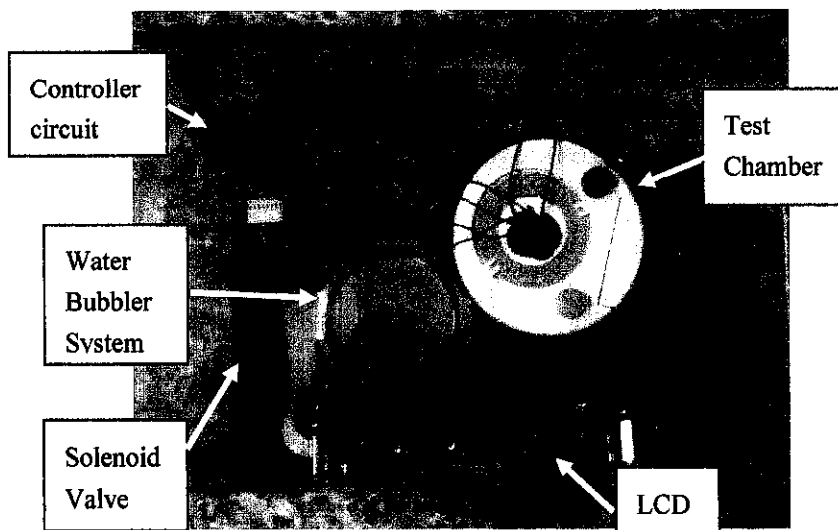

Figure 25 Humidity Control Chamber: Top View

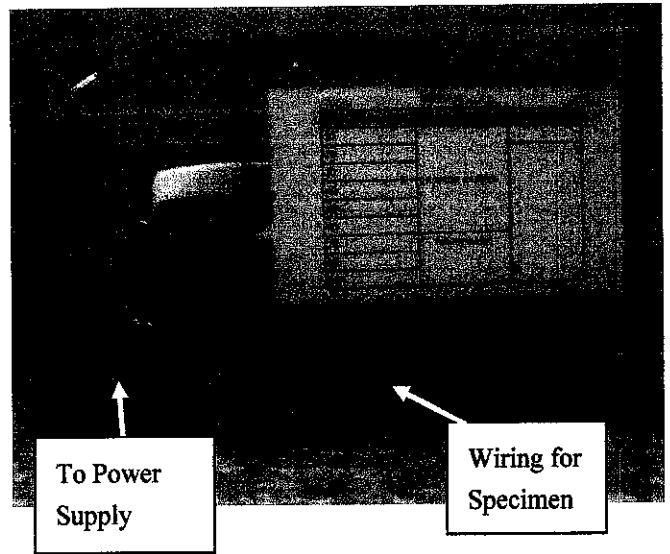

Figure 26 Humidity Test System: Front and Rear Views

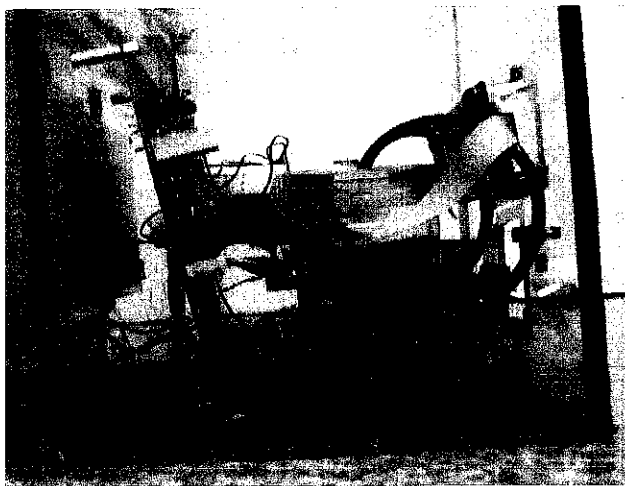

Figure 27 Humidity Test System: Side Views

CHAPTER 5

CONCLUSION AND RECOMMENDATION

5.1 Conclusion

This sensor test system design project would be significant enough to be continued in future. The initial idea might be simple, but it surely can be elaborated more and expanded from time to time.

During the Final Year Project I, the focus was actually getting initial ideas, understanding the basic concepts of humidity, designing the test system, finding suitable method in creating humidity, reviewing all parts involved in the system in details, and finally to initially design the controller circuit. Researches and literature reviews are done as it is believed that strong base is important when starting a new project. Troubleshooting and laboratory experiments have been conducted to ensure the reliability of the test system.

For the second semester, all circuit construction and test system fabrication work are done. The controller circuit has been designed, and then assembled, before testing and troubleshooting. Only then the circuit is connected to all the mechanical parts and work together as a whole. When everything is working properly, the circuit is reconstructed using PCB for efficiency, and longer life span. Enhancement work is also done so that the system would be portable and user friendly, suitable for maintenance purposes.

As experiments and tests are done on the overall connection, more new things are there to observe, learn, and understand. Hopefully, the project will actually return useful knowledge and experiences for future use.

5.2 Future Recommendations

Some improvements can be done in the future in order to make the system more practical and reliable. Accuracy has been the major concern for this project. It can be certainly be improved by using a more reliable and robust controller such as computer. PIC microcontroller has been a quite sensitive controller, where connections are sometimes not stable. It is also very fragile and easy to damage. Then, pressure of the dry air supply could be higher in order to make the low range wider, as the lowest that the system can now provide is about 13%RH. But, to implement this, the chamber and all mechanical connection have to be robust enough to withstand the high pressure. A heating element also could be introduced for a wider upper limit range of %RH of the test system. As for the noise created, maybe a noise filter could be implemented into the system to absorb it, and then improve the system to be more presentable.

REFERENCES

1. Wiederhold, Pieter, R. *Water Vapor Measurement*, Marcel Dekker, Inc.
2. <http://www.rentron.com/PICX1.htm> (Retrieved: January 15 2007)
3. http://documents.rs-components.com/rs-bin/RightSite.dll/getcontent/data.pdf?DMW_FORMAT=pdf&DMW_DOCBASE=techlib&DMW_OBJECTID=0900766b800b6bbd (Retrieved: February 10 2007)
4. Mr. Zuki, Microcontroller Crash Course Lecture Notes, UTP
5. <http://hyperphysics.phy-astr.gsu.edu/hbase/solids/trans.html> (Retrieved: February 25 2007)
6. http://www.winpicprog.co.uk/pic_tutorial_keypad_board.htm (Retrieved: February 26 2007)
7. <http://www.best-microcontroller-projects.com/lcd-volt-meter.html> (Retrieved: February 28 2007)
8. <http://www.cn-bote.com/cncpmore.asp?id=95> (Retrieved: March 8 2007)
9. <http://hyperphysics.phy-astr.gsu.edu/hbase/electronic/transwitch.html#c3> (Retrieved: March 13 2007)

APPENDICES

Appendix A	Gantt Chart
Appendix B	Drawings: Mechanical Parts
Appendix C	PIC 16F877 C Program
Appendix D	Datasheet for PIC 16F877 C
Appendix E	Datasheet for Honeywell HIH-4000 Series Humidity Sensor
Appendix F	Datasheet for 2N4401 NPN Switching Transistor
Appendix G	Datasheet for LM35 Temperature Sensor

APPENDIX A

GANTT CHART

APPENDIX B

DRAWINGS: MECHANICAL PARTS

TEST SYSTEM: OVERALL SIZING AND CONSTRUCTION

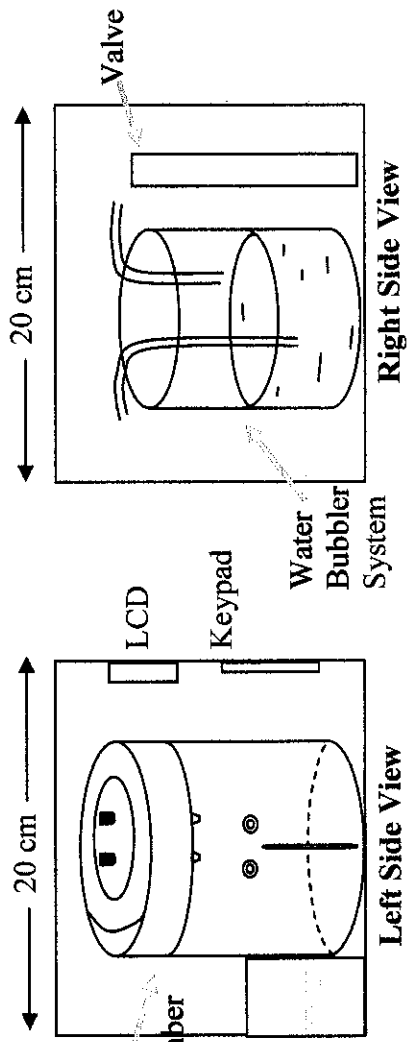
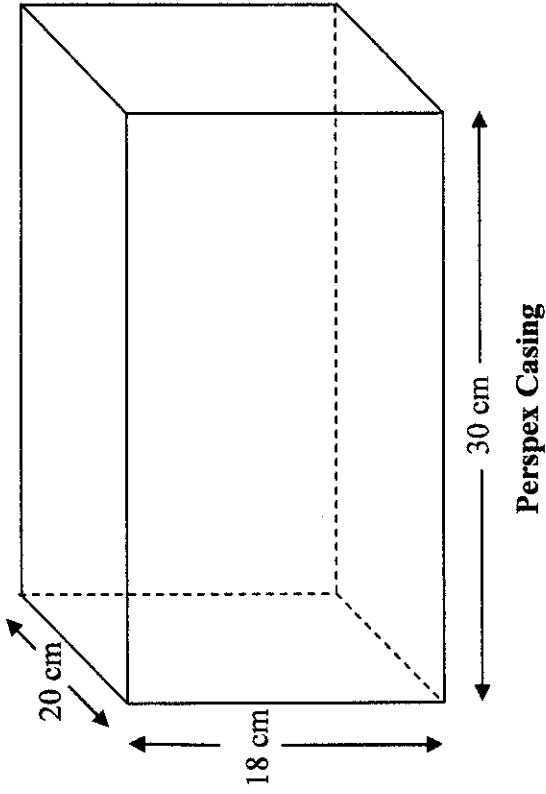
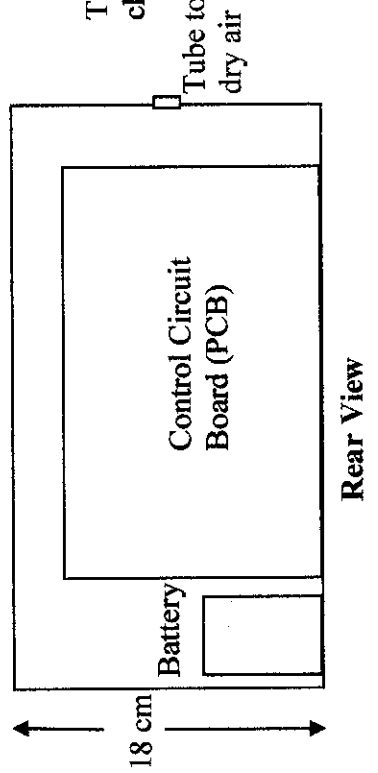
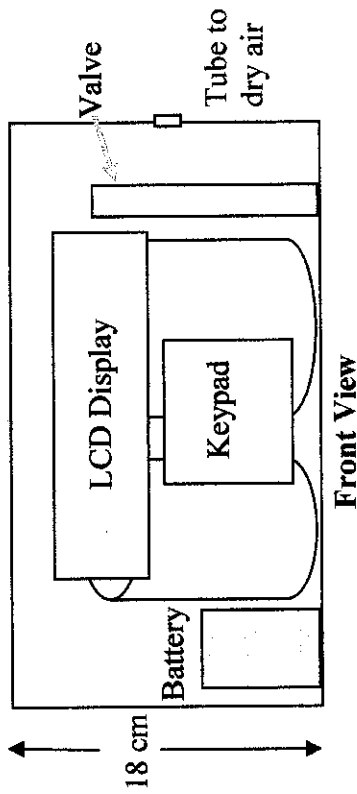
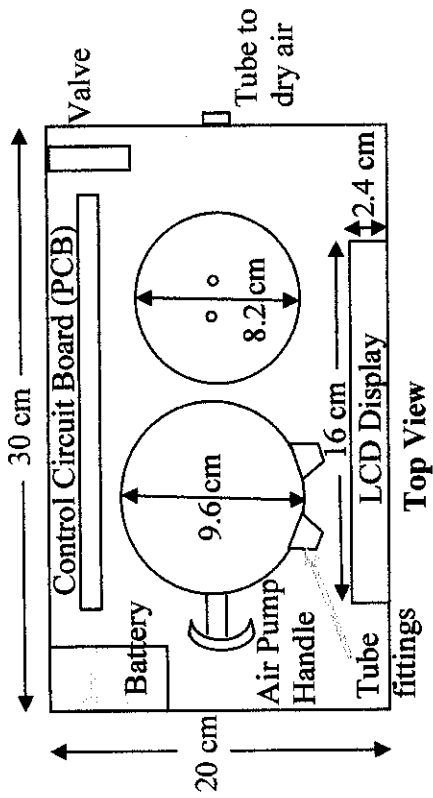

TEST CHAMBER: SIZING AND CONSTRUCTION

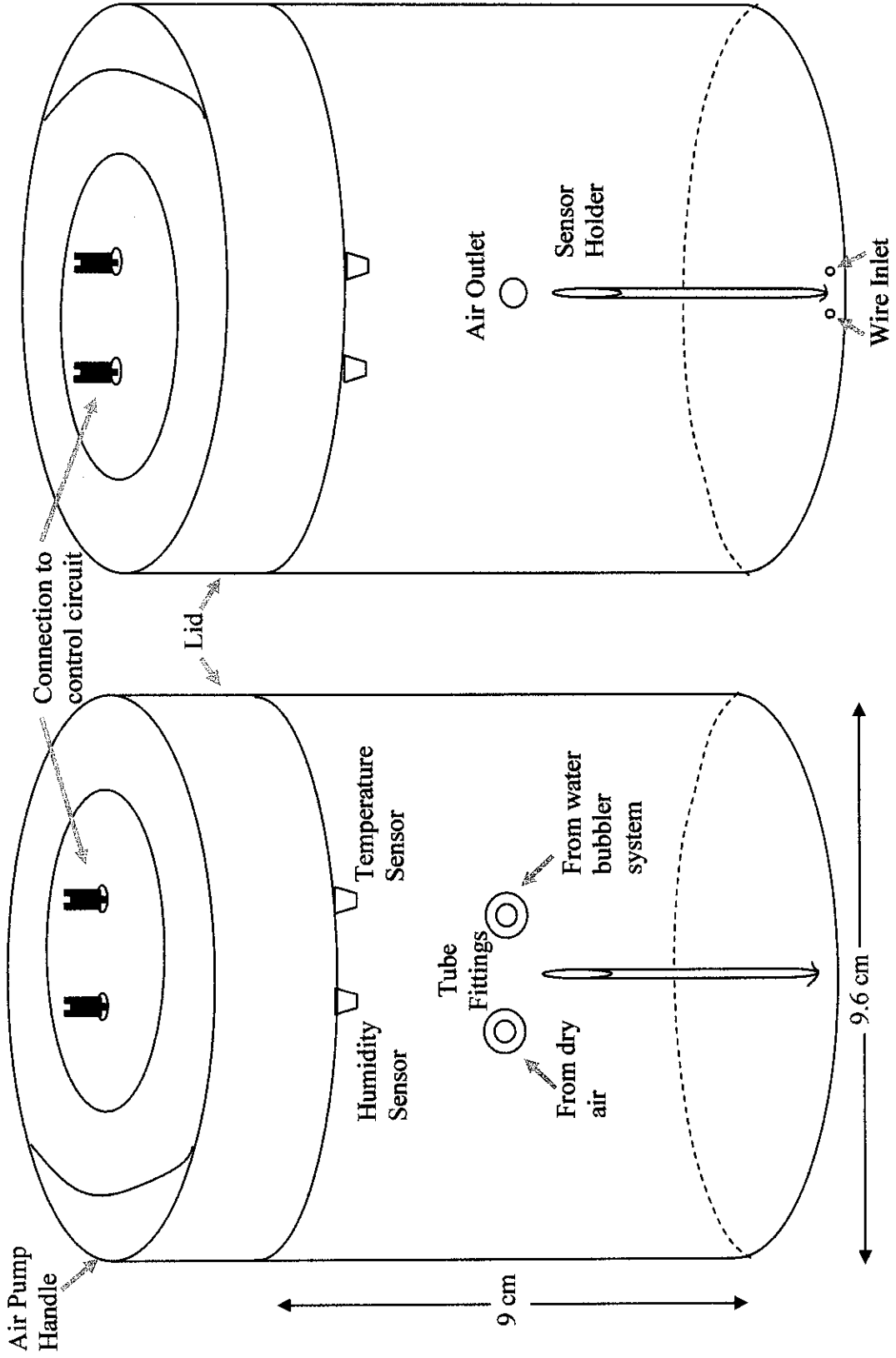

Chamber
Volume:
651.4 cm³

APPENDIX C

PIC16F877 C PROGRAM

PIC C Program

Main

```
#include <16F877.h>
#device ADC=8
#fuses XT, NOWDT, NOPROTECT, NOPUT, NOBROWNOUT, NOLVP
#use delay (clock=4000000)
#include <LCD.C>
#include <string.h>
#include <key_pad.c>
```

```
float adcValue;
float adcValue1;
float voltage;
float voltage1;
float humidity;
float temp;
int sum;
char k;
char l;
char c;
int i;
float adcValueU;
```

```
void main( )
{
```

```
    lcd_init();
    setup_adc_ports(ALL_ANALOG);
    setup_adc(ADC_CLOCK_INTERNAL);
```

```
    lcd_gotoxy(1,1);
    lcd_puts("RESET: Press Button");
```

```
    lcd_gotoxy(1,2);
    lcd_puts("Enter %RH value:");
```

```
    for(i=0; i<2; i++)
    {
        if(i==0)
        {
            delay_ms(100);
            k = get_key();
            sum = (int)k*10;
        }

        if(i==1)
        {
            delay_ms(50);
            l = get_key();
            sum += (int)l;
        }
    }
```

```
    lcd_gotoxy(18,2);
    lcd_putc(k);
    lcd_putc(l);
```

// This part will initialize the whole program, by including required drivers and devices. For example, as for this program, the PIC used would be 16F877A, that is why the device has to be included so that the program will recognise the device to be working as wanted.

// All variables will be initialized here, so that the program will know whether the name refers to float, integer or even character group.

// This will be the start of the main program

// LCD initialization
// Setting all adc ports to be analog.

// Requesting input from user, and informing that user has to press button to reset for a new value

// In order to limit the input to only two digits (0 to 99%RH), the 'for' loop is done. The sum indicates the value that the user has entered, which will be used to control the valve in the later part.

// The user input will be displayed in the second line, as indicated by the function lcd_gotoxy(). This function is initialized in LCD.c program which has been included in the first initialization part.

```

while (1)
{

set_adc_channel(0);
delay_us(30);
adcValue=read_adc();

voltage= 5.000*adcValue/255.000;
humidity = 1/0.0062 * (voltage/5.000 - 0.160);

delay_us(30);
set_adc_channel(1);
adcValue1=read_adc();

voltage1= 5.000*adcValue1/255.000;
temp = voltage1/0.01;

lcd_init();

lcd_gotoxy(1,1);
printf(lcd_putc,"%f", humidity);

lcd_gotoxy(7,1);
lcd_putc("%RH");

lcd_gotoxy(10,1);
lcd_putc(" ");
printf(lcd_putc,"%f", temp);

lcd_gotoxy(19,1);
lcd_putc("C ");

lcd_gotoxy(1,2);
lcd_putc("Required %RH:");
lcd_putc(k);
lcd_putc(l);

adcValueU= (0.0062*(sum - 16)+0.16)*255;

if(adcValue>=adcValueU)
{
output_high(pin_E0);
}
else
{
output_high(pin_E1);
}

delay_ms(2000);
}
}

```

// As user enters the needed value of %RH, the program will enter into a continuous forever loop.

// The adc port 0 will be set for current humidity reading. These equations will describe the relationships between adc values read, and humidity levels.

// The adc port 1 will be set for current temperature reading. These equations will describe the relationships between adc values read, and current temperature.

// Both current humidity and temperature values will be displayed on the LCD Display

// This equation will convert the user input into the equivalent adc value, so that the program can use it to compare and react.

// This part is done to control the valve. If the current %RH value is above the requested value, the valve will be shut off and vice versa.

// End program

Keypad

```
##byte port_d = 0x08

char get_key(void)
{
    char t;

    while (1) {

        output_d(input_d() | 0xFF); /* set RD4 to low to scan the first row */
        output_bit(PIN_D4,0);

        if (input(PIN_D0) == 0) {
            delay_us(10);

            while(input(PIN_D0) == 0)
            {
            }

            return 'A'; /* return the ASCII code of A */
        }

        if (input(PIN_D1) == 0) {
            delay_ms(10);
            while(input(PIN_D1) == 0)
            {
            }

            return '7'; /* return the ASCII code of 7 */
        }

        if (input(PIN_D2) == 0) {
            delay_ms(10);
            while(input(PIN_D2) == 0)
            {
            }

            return '4'; /* return the ASCII code of 4 */
        }

        if (input(PIN_D3) == 0) {
            delay_ms(10);
            while(input(PIN_D3) == 0)
            {
            }

            return '1'; /* return the ASCII code of 1 */
        }

        output_d(input_d() | 0xFF); /* set RD5 to low to scan the second row */
        output_bit(PIN_D5,0);
        if (input(PIN_D0) == 0) {
            delay_ms(10);

            while(input(PIN_D0) == 0)
            {
            }

            return '0'; /* return the ASCII code of 0 */
        }
    }
}
```



```

        if (input(PIN_D1)==0) {
            delay_ms(10);
while(input(PIN_D1)==0)
{
}

            return '8'; /* return the ASCII code of 8 */
        }

        if (input(PIN_D2)==0) {
            delay_ms(10);
while(input(PIN_D2)==0)
{
}

            return '5'; /* return the ASCII code of 5 */
        }

        if (input(PIN_D3)==0) {
            delay_ms(10);
while(input(PIN_D3)==0)
{
}

            return '2'; /* return the ASCII code of 2 */
        }

output_d(input_d()|0xFF); /* set RD6 to low to scan the third row */
output_bit(PIN_D6,0);
if (input(PIN_D0)==0) {
    delay_ms(10);
while(input(PIN_D0)==0)
{
}

            return 'B'; /* return the ASCII code of B */
        }

        if (input(PIN_D1)==0) {
            delay_ms(10);
while(input(PIN_D1)==0)
{
}

            return '9'; /* return the ASCII code of 9 */
        }

        if (input(PIN_D2)==0) {
            delay_ms(10);
while(input(PIN_D2)==0)
{
}

            return '6'; /* return the ASCII code of 6 */
        }

        if (input(PIN_D3)==0) {
            delay_ms(10);
while(input(PIN_D3)==0)
{
}

```

```

        return '3'; /* return the ASCII code of 3 */
    }

output_d(input_d() | 0xFF); /* set RD7 to low to scan the fourth row */
    output_bit(PIN_D7,0);
    if (input(PIN_D0) == 0) {
        delay_ms(10);
    while(input(PIN_D0) == 0)
    {
    }

        return 'C'; /* return the ASCII code of C */
    }

    if (input(PIN_D1) == 0) {
        delay_ms(10);
    while(input(PIN_D1) == 0)
    {
    }

        return 'D'; /* return the ASCII code of D */
    }

    if (input(PIN_D2) == 0) {
        delay_ms(10);
    while(input(PIN_D2) == 0)
    {
    }

        return 'E'; /* return the ASCII code of E */
    }

    if (input(PIN_D3) == 0) {
        delay_ms(10);
    while(input(PIN_D3) == 0)
    {
    }

        return 'F'; /* return the ASCII code of F */
    }
}

```

LCD

```
//////////////////////////////////////////////////////////////////
////          LCDD.C
////          Driver for common LCD modules
////
//// lcd_init() Must be called before any other function.
////
//// lcd_putc(c) Will display c on the next position of the LCD.
////          The following have special meaning:
////          \f Clear display
////          \n Go to start of second line
////          \b Move back one position
////
//// lcd_gotoxy(x,y) Set write position on LCD (upper left is 1,1)
////
//// lcd_getc(x,y) Returns character at position x,y on LCD
////
//////////////////////////////////////////////////////////////////
//// (C) Copyright 1996,2003 Custom Computer Services
//// This source code may only be used by licensed users of the CCS C
//// compiler. This source code may only be distributed to other
//// licensed users of the CCS C compiler. No other use, reproduction
//// or distribution is permitted without written permission.
//// Derivative programs created using this software in object code
//// form are not restricted in any way.
//////////////////////////////////////////////////////////////////

// As defined in the following structure the pin connection is as follows:
// RB0 Chip Enable (CE)
// RB1 Register Select (RS)
// RB2 Read/Write* (R/W*)
// RB4 Data Bit 4 (DB4)
// RB5 Data Bit 5 (DB5)
// RB6 Data Bit 6 (DB6)
// RB7 Data Bit 7 (DB7)
//
// LCD pins DB0-DB3 are not used and PIC's RB3 is not used.

// Un-comment the following define to use port B
#define use_portb_lcd TRUE

struct lcd_pin_map {          // This structure is overlaid
    BOOLEAN enable;          // on to an I/O port to gain
    BOOLEAN rs;              // access to the LCD pins.
    BOOLEAN rw;              // The bits are allocated from
    BOOLEAN unused;          // low order up. ENABLE will
    int data : 4;            // be pin B0.
} lcd;

#if defined(__PCH__)
#if defined use_portb_lcd
    #byte lcd = 0xF81          // This puts the entire structure
#else
    #byte lcd = 0xF83          // This puts the entire structure
#endif
#else
#if defined use_portb_lcd
    #byte lcd = 6              // on to port B (at address 6)
#else
    #byte lcd = 8              // on to port D (at address 8)
#endif
#endif

#if defined use_portb_lcd
    #define set_tris_lcd(x) set_tris_b(x)
#endif
```

```

#else
#define set_tris_lcd(x) set_tris_d(x)
#endif

#define lcd_type 2 // 0=5x7, 1=5x10, 2=2 lines
#define lcd_line_two 0x40 // LCD RAM address for the second line

BYTE const LCD_INIT_STRING[4] = {0x20 | (lcd_type << 2), 0xc, 1, 6};
// These bytes need to be sent to the LCD
// to start it up.

// The following are used for setting
// the I/O port direction register.

struct lcd_pin_map const LCD_WRITE = {0,0,0,0,0}; // For write mode all pins are out
struct lcd_pin_map const LCD_READ = {0,0,0,0,15}; // For read mode data pins are in

BYTE lcd_read_byte() {
    BYTE low,high;
    set_tris_lcd(LCD_READ);
    lcd.rw = 1;
    delay_cycles(1);
    lcd.enable = 1;
    delay_cycles(1);
    high = lcd.data;
    lcd.enable = 0;
    delay_cycles(1);
    lcd.enable = 1;
    delay_us(1);
    low = lcd.data;
    lcd.enable = 0;
    set_tris_lcd(LCD_WRITE);
    return( (high<<4) | low);
}

void lcd_send_nibble( BYTE n ) {
    lcd.data = n;
    delay_cycles(1);
    lcd.enable = 1;
    delay_us(2);
    lcd.enable = 0;
}

void lcd_send_byte( BYTE address, BYTE n ) {
    lcd.rs = 0;
    while ( bit_test(lcd_read_byte(),7) );
    lcd.rs = address;
    delay_cycles(1);
    lcd.rw = 0;
    delay_cycles(1);
    lcd.enable = 0;
    lcd_send_nibble(n >> 4);
    lcd_send_nibble(n & 0xf);
}

void lcd_init() {
    BYTE i;
    set_tris_lcd(LCD_WRITE);
    lcd.rs = 0;
    lcd.rw = 0;
    lcd.enable = 0;
}

```

```

delay_ms(15);
for(i=1;i<=3;++i) {
    lcd_send_nibble(3);
    delay_ms(5);
}
lcd_send_nibble(2);
for(i=0;i<=3;++i)
    lcd_send_byte(0,LCD_INIT_STRING[i]);
}

```

```

void lcd_gotoxy( BYTE x, BYTE y) {
    BYTE address;

    if(y!=1)
        address=lcd_line_two;
    else
        address=0;
    address+=x-1;
    lcd_send_byte(0,0x80|address);
}

```

```

void lcd_putc( char c) {
    switch (c) {
        case '^P' : lcd_send_byte(0,1);
                    delay_ms(2);
                    break;
        case '^n' : lcd_gotoxy(1,2); break;
        case '^b' : lcd_send_byte(0,0x10); break;
        default  : lcd_send_byte(1,c); break;
    }
}

```

```

char lcd_getc( BYTE x, BYTE y) {
    char value;

    lcd_gotoxy(x,y);
    while ( bit_test(lcd_read_byte(),7) ); // wait until busy flag is low
    lcd.rs=1;
    value = lcd_read_byte();
    lcd.rs=0;
    return(value);
}

```

APPENDIX D

PIC16F877 DATASHEET



MICROCHIP

PIC16F87X

28/40-Pin 8-Bit CMOS FLASH Microcontrollers

Devices Included in this Data Sheet:

- PIC16F873
- PIC16F876
- PIC16F874
- PIC16F877

Microcontroller Core Features:

- High performance RISC CPU
- Only 35 single word instructions to learn
- All single cycle instructions except for program branches which are two cycle
- Operating speed: DC - 20 MHz clock input
DC - 200 ns instruction cycle
- Up to 8K x 14 words of FLASH Program Memory,
Up to 368 x 8 bytes of Data Memory (RAM)
Up to 256 x 8 bytes of EEPROM Data Memory
- Pinout compatible to the PIC16C73B/74B/76/77
- Interrupt capability (up to 14 sources)
- Eight level deep hardware stack
- Direct, indirect and relative addressing modes
- Power-on Reset (POR)
- Power-up Timer (PWRT) and
Oscillator Start-up Timer (OST)
- Watchdog Timer (WDT) with its own on-chip RC
oscillator for reliable operation
- Programmable code protection
- Power saving SLEEP mode
- Selectable oscillator options
- Low power, high speed CMOS FLASH/EEPROM
technology
- Fully static design
- In-Circuit Serial Programming™ (ICSP) via two
pins
- Single 5V In-Circuit Serial Programming capability
- In-Circuit Debugging via two pins
- Processor read/write access to program memory
- Wide operating voltage range: 2.0V to 5.5V
- High Sink/Source Current: 25 mA
- Commercial, Industrial and Extended temperature
ranges
- Low-power consumption:
 - < 0.6 mA typical @ 3V, 4 MHz
 - 20 µA typical @ 3V, 32 kHz
 - < 1 µA typical standby current

Pin Diagram

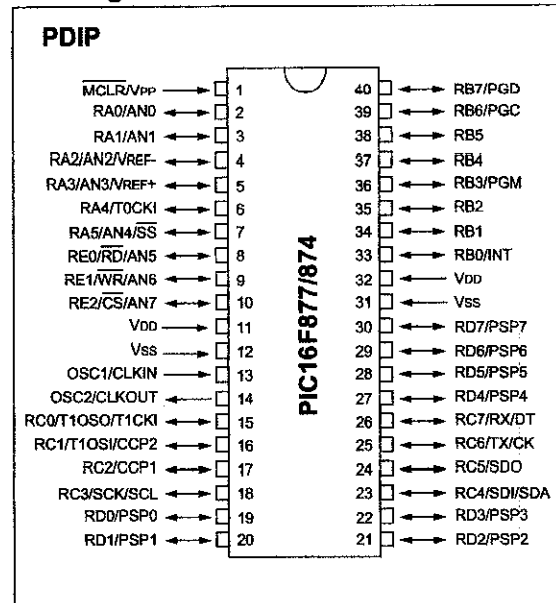

Peripheral Features:

- Timer0: 8-bit timer/counter with 8-bit prescaler
- Timer1: 16-bit timer/counter with prescaler,
can be incremented during SLEEP via external
crystal/clock
- Timer2: 8-bit timer/counter with 8-bit period
register, prescaler and postscaler
- Two Capture, Compare, PWM modules
 - Capture is 16-bit, max. resolution is 12.5 ns
 - Compare is 16-bit, max. resolution is 200 ns
 - PWM max. resolution is 10-bit
- 10-bit multi-channel Analog-to-Digital converter
- Synchronous Serial Port (SSP) with SPI™ (Master
mode) and I²C™ (Master/Slave)
- Universal Synchronous Asynchronous Receiver
Transmitter (USART/SCI) with 9-bit address
detection
- Parallel Slave Port (PSP) 8-bits wide, with
external \overline{RD} , \overline{WR} and \overline{CS} controls (40/44-pin only)
- Brown-out detection circuitry for
Brown-out Reset (BOR)

PIC16F87X

Pin Diagrams

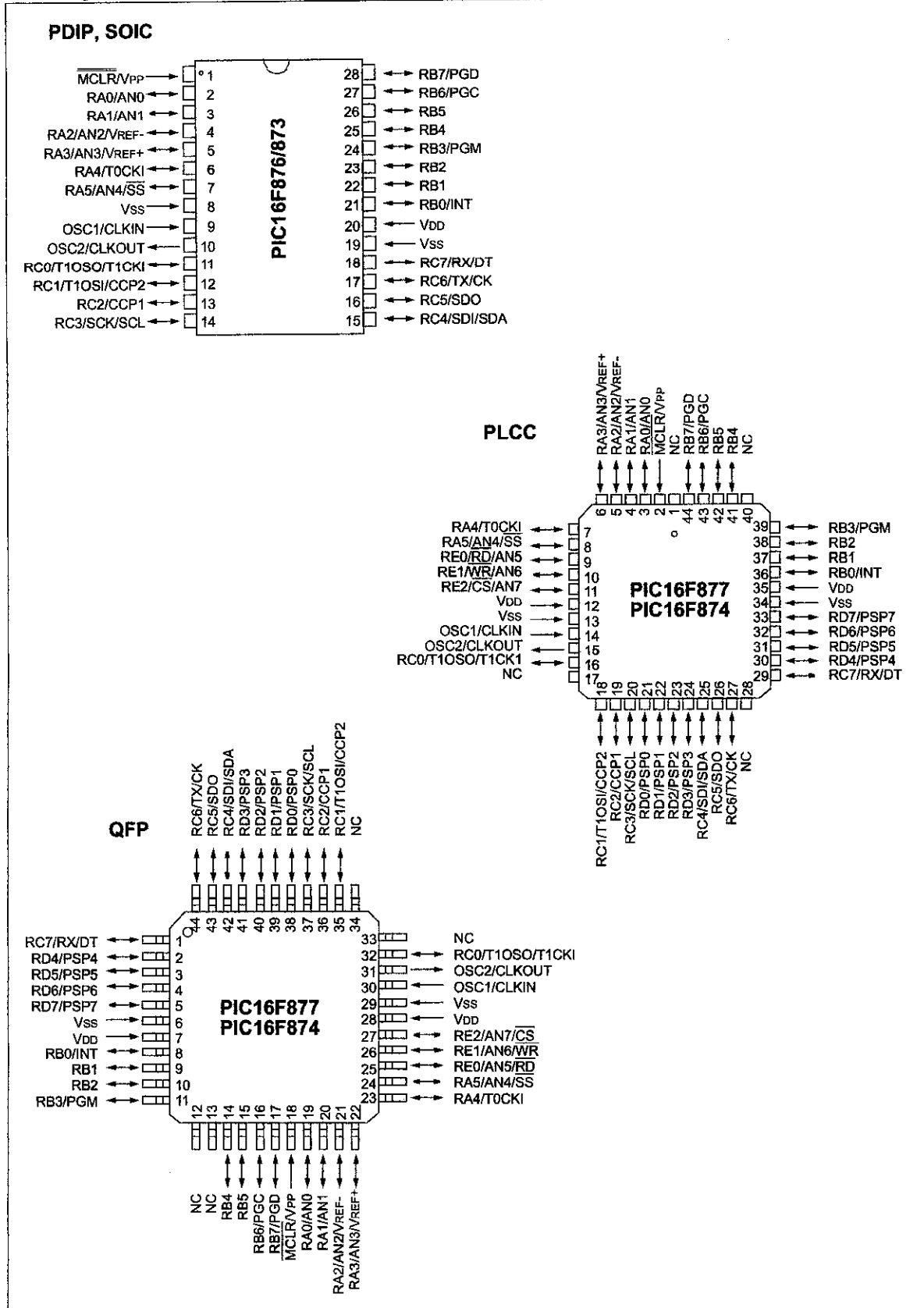

Key Features PICmicro™ Mid-Range Reference Manual (DS33023)	PIC16F873	PIC16F874	PIC16F876	PIC16F877
Operating Frequency	DC - 20 MHz	DC - 20 MHz	DC - 20 MHz	DC - 20 MHz
RESETS (and Delays)	POR, BOR (PWRT, OST)	POR, BOR (PWRT, OST)	POR, BOR (PWRT, OST)	POR, BOR (PWRT, OST)
FLASH Program Memory (14-bit words)	4K	4K	8K	8K
Data Memory (bytes)	192	192	368	368
EEPROM Data Memory	128	128	256	256
Interrupts	13	14	13	14
I/O Ports	Ports A,B,C	Ports A,B,C,D,E	Ports A,B,C	Ports A,B,C,D,E
Timers	3	3	3	3
Capture/Compare/PWM Modules	2	2	2	2
Serial Communications	MSSP, USART	MSSP, USART	MSSP, USART	MSSP, USART
Parallel Communications	—	PSP	—	PSP
10-bit Analog-to-Digital Module	5 input channels	8 input channels	5 input channels	8 input channels
Instruction Set	35 instructions	35 instructions	35 instructions	35 instructions

TABLE 1-1: PIC16F873 AND PIC16F876 PINOUT DESCRIPTION

Pin Name	DIP Pin#	SOIC Pin#	I/O/P Type	Buffer Type	Description
OSC1/CLKIN	9	9	I	ST/CMOS ⁽³⁾	Oscillator crystal input/external clock source input.
OSC2/CLKOUT	10	10	O	—	Oscillator crystal output. Connects to crystal or resonator in crystal oscillator mode. In RC mode, the OSC2 pin outputs CLKOUT which has 1/4 the frequency of OSC1, and denotes the instruction cycle rate.
MCLR/PP	1	1	I/P	ST	Master Clear (Reset) input or programming voltage input. This pin is an active low RESET to the device.
RA0/AN0	2	2	I/O	TTL	<p>PORTA is a bi-directional I/O port.</p> <p>RA0 can also be analog input0.</p> <p>RA1 can also be analog input1.</p> <p>RA2 can also be analog input2 or negative analog reference voltage.</p> <p>RA3 can also be analog input3 or positive analog reference voltage.</p> <p>RA4 can also be the clock input to the Timer0 module. Output is open drain type.</p> <p>RA5 can also be analog input4 or the slave select for the synchronous serial port.</p>
RA1/AN1	3	3	I/O	TTL	
RA2/AN2/VREF-	4	4	I/O	TTL	
RA3/AN3/VREF+	5	5	I/O	TTL	
RA4/T0CKI	6	6	I/O	ST	
RA5/SS/AN4	7	7	I/O	TTL	
RB0/INT	21	21	I/O	TTL/ST ⁽¹⁾	<p>PORTB is a bi-directional I/O port. PORTB can be software programmed for internal weak pull-up on all inputs.</p> <p>RB0 can also be the external interrupt pin.</p> <p>RB3 can also be the low voltage programming input.</p> <p>Interrupt-on-change pin.</p> <p>Interrupt-on-change pin.</p> <p>Interrupt-on-change pin or In-Circuit Debugger pin. Serial programming clock.</p> <p>Interrupt-on-change pin or In-Circuit Debugger pin. Serial programming data.</p>
RB1	22	22	I/O	TTL	
RB2	23	23	I/O	TTL	
RB3/PGM	24	24	I/O	TTL	
RB4	25	25	I/O	TTL	
RB5	26	26	I/O	TTL	
RB6/PGC	27	27	I/O	TTL/ST ⁽²⁾	
RB7/PGD	28	28	I/O	TTL/ST ⁽²⁾	
RC0/T1OSO/T1CKI	11	11	I/O	ST	<p>PORTC is a bi-directional I/O port.</p> <p>RC0 can also be the Timer1 oscillator output or Timer1 clock input.</p> <p>RC1 can also be the Timer1 oscillator input or Capture2 input/Compare2 output/PWM2 output.</p> <p>RC2 can also be the Capture1 input/Compare1 output/PWM1 output.</p> <p>RC3 can also be the synchronous serial clock input/output for both SPI and I²C modes.</p> <p>RC4 can also be the SPI Data In (SPI mode) or data I/O (I²C mode).</p> <p>RC5 can also be the SPI Data Out (SPI mode).</p> <p>RC6 can also be the USART Asynchronous Transmit or Synchronous Clock.</p> <p>RC7 can also be the USART Asynchronous Receive or Synchronous Data.</p>
RC1/T1OSI/CCP2	12	12	I/O	ST	
RC2/CCP1	13	13	I/O	ST	
RC3/SCK/SCL	14	14	I/O	ST	
RC4/SDI/SDA	15	15	I/O	ST	
RC5/SDO	16	16	I/O	ST	
RC6/TX/CK	17	17	I/O	ST	
RC7/RX/DT	18	18	I/O	ST	
Vss	8, 19	8, 19	P	—	Ground reference for logic and I/O pins.
VDD	20	20	P	—	Positive supply for logic and I/O pins.

Legend: I = input O = output I/O = input/output P = power
 — = Not used TTL = TTL input ST = Schmitt Trigger input

- Note 1:** This buffer is a Schmitt Trigger input when configured as the external interrupt.
Note 2: This buffer is a Schmitt Trigger input when used in Serial Programming mode.
Note 3: This buffer is a Schmitt Trigger input when configured in RC oscillator mode and a CMOS input otherwise.

PIC16F87X

TABLE 1-2: PIC16F874 AND PIC16F877 PINOUT DESCRIPTION

Pin Name	DIP Pin#	PLCC Pin#	QFP Pin#	I/O/P Type	Buffer Type	Description
OSC1/CLKIN	13	14	30	I	ST/CMOS ⁽⁴⁾	Oscillator crystal input/external clock source input.
OSC2/CLKOUT	14	15	31	O	—	Oscillator crystal output. Connects to crystal or resonator in crystal oscillator mode. In RC mode, OSC2 pin outputs CLKOUT which has 1/4 the frequency of OSC1, and denotes the instruction cycle rate.
MCLR/VPP	1	2	18	I/P	ST	Master Clear (Reset) input or programming voltage input. This pin is an active low RESET to the device.
RA0/AN0	2	3	19	I/O	TTL	<p>PORTA is a bi-directional I/O port.</p> <p>RA0 can also be analog input0.</p> <p>RA1 can also be analog input1.</p> <p>RA2 can also be analog input2 or negative analog reference voltage.</p> <p>RA3 can also be analog input3 or positive analog reference voltage.</p> <p>RA4 can also be the clock input to the Timer0 timer/counter. Output is open drain type.</p> <p>RA5 can also be analog input4 or the slave select for the synchronous serial port.</p>
RA1/AN1	3	4	20	I/O	TTL	
RA2/AN2/VREF-	4	5	21	I/O	TTL	
RA3/AN3/VREF+	5	6	22	I/O	TTL	
RA4/T0CKI	6	7	23	I/O	ST	
RA5/SS/AN4	7	8	24	I/O	TTL	
RB0/INT	33	36	8	I/O	TTL/ST ⁽¹⁾	<p>PORTB is a bi-directional I/O port. PORTB can be software programmed for internal weak pull-up on all inputs.</p> <p>RB0 can also be the external interrupt pin.</p> <p>RB3 can also be the low voltage programming input.</p> <p>Interrupt-on-change pin.</p> <p>Interrupt-on-change pin.</p> <p>Interrupt-on-change pin or In-Circuit Debugger pin. Serial programming clock.</p> <p>Interrupt-on-change pin or In-Circuit Debugger pin. Serial programming data.</p>
RB1	34	37	9	I/O	TTL	
RB2	35	38	10	I/O	TTL	
RB3/PGM	36	39	11	I/O	TTL	
RB4	37	41	14	I/O	TTL	
RB5	38	42	15	I/O	TTL	
RB6/PGC	39	43	16	I/O	TTL/ST ⁽²⁾	
RB7/PGD	40	44	17	I/O	TTL/ST ⁽²⁾	

Legend: I = input O = output I/O = input/output P = power
 — = Not used TTL = TTL input ST = Schmitt Trigger input

- Note 1:** This buffer is a Schmitt Trigger input when configured as an external interrupt.
Note 2: This buffer is a Schmitt Trigger input when used in Serial Programming mode.
Note 3: This buffer is a Schmitt Trigger input when configured as general purpose I/O and a TTL input when used in the Parallel Slave Port mode (for interfacing to a microprocessor bus).
Note 4: This buffer is a Schmitt Trigger input when configured in RC oscillator mode and a CMOS input otherwise.

TABLE 1-2: PIC16F874 AND PIC16F877 PINOUT DESCRIPTION (CONTINUED)

Pin Name	DIP Pin#	PLCC Pin#	QFP Pin#	I/O/P Type	Buffer Type	Description
RC0/T1OSO/T1CKI	15	16	32	I/O	ST	PORTC is a bi-directional I/O port. RC0 can also be the Timer1 oscillator output or a Timer1 clock input. RC1 can also be the Timer1 oscillator input or Capture2 input/Compare2 output/PWM2 output. RC2 can also be the Capture1 input/Compare1 output/PWM1 output. RC3 can also be the synchronous serial clock input/output for both SPI and I ² C modes. RC4 can also be the SPI Data In (SPI mode) or data I/O (I ² C mode). RC5 can also be the SPI Data Out (SPI mode). RC6 can also be the USART Asynchronous Transmit or Synchronous Clock. RC7 can also be the USART Asynchronous Receive or Synchronous Data.
RC1/T1OSI/CCP2	16	18	35	I/O	ST	
RC2/CCP1	17	19	36	I/O	ST	
RC3/SCK/SCL	18	20	37	I/O	ST	
RC4/SDI/SDA	23	25	42	I/O	ST	
RC5/SDO	24	26	43	I/O	ST	
RC6/TX/CK	25	27	44	I/O	ST	
RC7/RX/DT	26	29	1	I/O	ST	
RD0/PSP0	19	21	38	I/O	ST/TTL ⁽³⁾	PORTD is a bi-directional I/O port or parallel slave port when interfacing to a microprocessor bus.
RD1/PSP1	20	22	39	I/O	ST/TTL ⁽³⁾	
RD2/PSP2	21	23	40	I/O	ST/TTL ⁽³⁾	
RD3/PSP3	22	24	41	I/O	ST/TTL ⁽³⁾	
RD4/PSP4	27	30	2	I/O	ST/TTL ⁽³⁾	
RD5/PSP5	28	31	3	I/O	ST/TTL ⁽³⁾	
RD6/PSP6	29	32	4	I/O	ST/TTL ⁽³⁾	
RD7/PSP7	30	33	5	I/O	ST/TTL ⁽³⁾	
RE0/ \overline{RD} /AN5	8	9	25	I/O	ST/TTL ⁽³⁾	PORTE is a bi-directional I/O port. RE0 can also be read control for the parallel slave port, or analog input5. RE1 can also be write control for the parallel slave port, or analog input6. RE2 can also be select control for the parallel slave port, or analog input7.
RE1/ \overline{WR} /AN6	9	10	26	I/O	ST/TTL ⁽³⁾	
RE2/ \overline{CS} /AN7	10	11	27	I/O	ST/TTL ⁽³⁾	
VSS	12,31	13,34	6,29	P	—	Ground reference for logic and I/O pins.
VDD	11,32	12,35	7,28	P	—	Positive supply for logic and I/O pins.
NC	—	1,17,28,40	12,13,33,34		—	These pins are not internally connected. These pins should be left unconnected.

Legend: I = input O = output I/O = input/output P = power
 — = Not used TTL = TTL input ST = Schmitt Trigger input

- Note 1:** This buffer is a Schmitt Trigger input when configured as an external interrupt.
Note 2: This buffer is a Schmitt Trigger input when used in Serial Programming mode.
Note 3: This buffer is a Schmitt Trigger input when configured as general purpose I/O and a TTL input when used in the Parallel Slave Port mode (for interfacing to a microprocessor bus).
Note 4: This buffer is a Schmitt Trigger input when configured in RC oscillator mode and a CMOS input otherwise.

APPENDIX E

HUMIDITY SENSOR DATASHEET

Humidity Sensors

Humidity Sensor

HIH-3610 Series

FEATURES

- Molded thermoset plastic housing with cover
- Linear voltage output vs %RH
- Laser trimmed interchangeability
- Low power design
- High accuracy
- Fast response time
- Stable, low drift performance
- Chemically resistant

TYPICAL APPLICATIONS

- Refrigeration
- Drying
- Metrology
- Battery-powered systems
- OEM assemblies

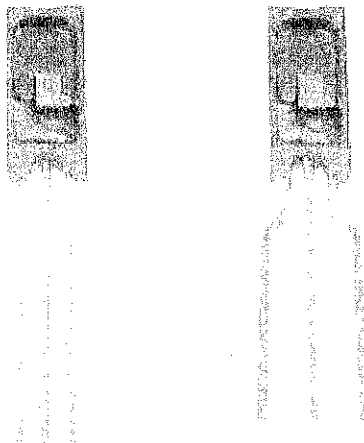

The HIH-3610 Series humidity sensor is designed specifically for high volume OEM (Original Equipment Manufacturer) users. Direct input to a controller or other device is made possible by this sensor's linear voltage output. With a typical current draw of only 200 μ A, the HIH-3610 Series is ideally suited for low drain, battery operated systems. Tight sensor interchangeability reduces or eliminates OEM production calibration costs. Individual sensor calibration data is available.

The HIH-3610 Series delivers instrumentation-quality RH (Relative Humidity) sensing performance in a low cost, solderable SIP (Single In-line Package). Available in two lead spacing configurations, the RH sensor is a laser trimmed thermoset polymer capacitive sensing element with on-chip integrated signal conditioning. The sensing element's multilayer construction provides excellent resistance to application hazards such as wetting, dust, dirt, oils, and common environmental chemicals.

▲WARNING

PERSONAL INJURY

- DO NOT USE these products as safety or emergency stop devices, or in any other application where failure of the product could result in personal injury.

Failure to comply with these instructions could result in death or serious injury.

▲WARNING

MISUSE OF DOCUMENTATION

- The information presented in this product sheet is for reference only. Do not use this document as system installation information
- Complete installation, operation, and maintenance information is provided in the instructions supplied with each product.

Failure to comply with these instructions could result in death or serious injury.

Humidity Sensors

Humidity Sensor

HH-3610 Series

TABLE 1: PERFORMANCE SPECIFICATIONS

Parameter	Condition
RH Accuracy ⁽¹⁾	±2% RH, 0-100% RH non-condensing, 25 °C, V _{supply} = 5 Vdc
RH Interchangeability	±5% RH, 0-60% RH; ±8% @ 90% RH typical
RH Linearity	±0.5% RH typical
RH Hysteresis	±1.2% RH span maximum
RH Repeatability	±0.5% RH
RH Response Time, 1/e	15 sec in slowly moving air at 25 °C
RH Stability	±1% RH typical at 50% RH in 5 years
Power Requirements	
Voltage Supply	4 Vdc to 5.8 Vdc, sensor calibrated at 5 Vdc
Current Supply	200 µA at 5 Vdc
Voltage Output	V _{out} = V _{supply} (0.0062(Sensor RH) + 0.16), typical @ 25 °C (Data printout option provides a similar, but sensor specific, equation at 25 °C.)
V _{supply} = 5 Vdc	0.8 Vdc to 3.9 Vdc output @ 25 °C typical
Drive Limits	Push/pull symmetric; 50 µA typical, 20 µA minimum, 100 µA maximum Turn-on ≤ 0.1 sec
Temperature Compensation	True RH = (Sensor RH)/(1.093-0.0021T), T in °F True RH = (Sensor RH)/(1.0546-0.00216T), T in °C
Effect @ 0% RH	±0.007 %RH/°C (negligible)
Effect @ 100% RH	-0.22% RH/°C (<1% RH effect typical in occupied space systems above 15 °C (59 °F))
Humidity Range	
Operating	0 to 100% RH, non-condensing ⁽¹⁾
Storage	0 to 90% RH, non-condensing
Temperature Range	
Operating	-40 °C to 85 °C (-40 °F to 185 °F)
Storage	-51 °C to 125 °C (-60 °F to 257 °F)
Package ⁽²⁾	Three pin, solderable SIP in molded thermoset plastic housing with thermoplastic cover
Handling	Static sensitive diode protected to 15 kV maximum

Notes:

1. Extended exposure to ≥90% RH causes a reversible shift of 3% RH.
2. This sensor is light sensitive. For best results, shield the sensor from bright light.



Humidity/Moisture Sensors

Humidity Sensor

HIH-3610 Series

FACTORY CALIBRATION

HIH-3610 sensors may be ordered with a calibration and data printout (Table 2). See order guide on back page.

TABLE 2: EXAMPLE DATA PRINTOUT

Model	HIH-3610-001
Channel	92
Wafer	030996M
MRP	337313
Calculated values at 5 V	
V _{out} @ 0% RH	0.958 V
V _{out} @ 75.3% RH	3.268 V
Linear output for 2% RH accuracy @ 25 °C	
Zero offset	0.958 V
Slope	30.680 mV/%RH
RH	(V _{out} -zero offset)/slope (V _{out} -0.958)/0.0307
Ratiometric response for 0 to 100% RH	
V _{out}	V _{supply} (0.1915 to 0.8130)

FIGURE 1: RH SENSOR CONSTRUCTION

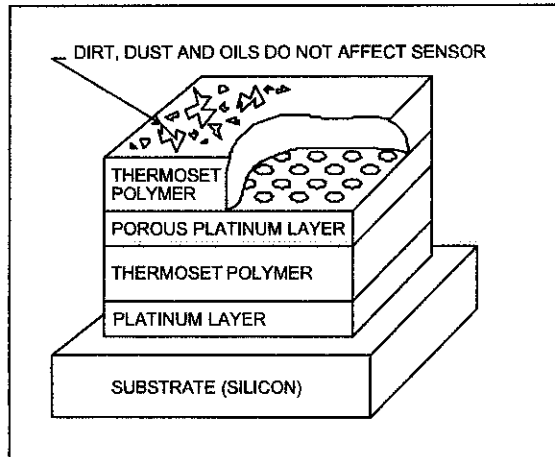

FIGURE 2: OUTPUT VOLTAGE VS RELATIVE HUMIDITY AT 0 °C

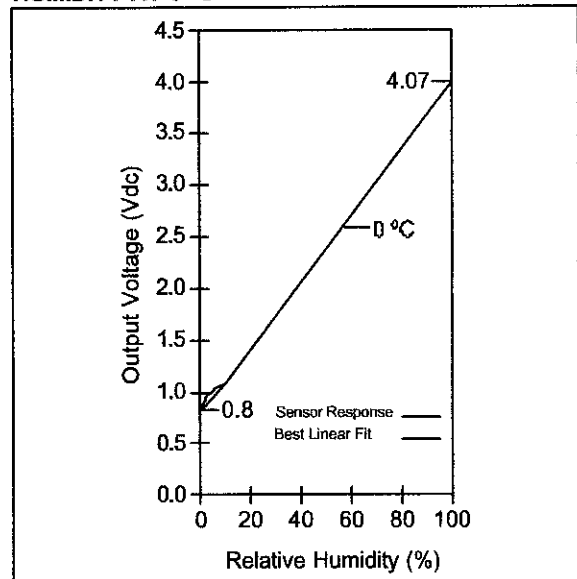
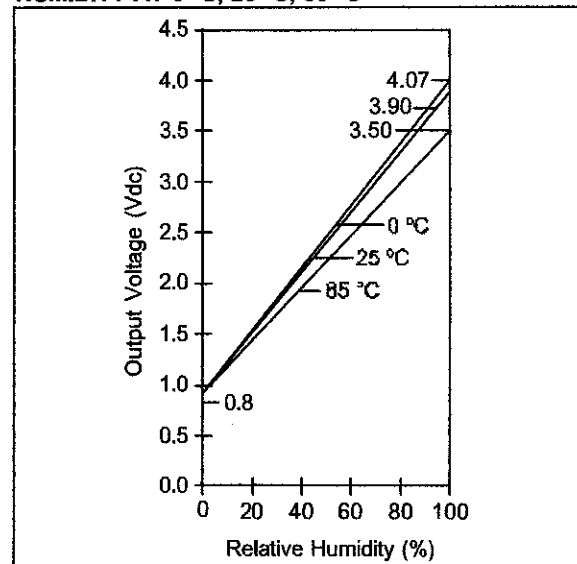

FIGURE 3: OUTPUT VOLTAGE VS RELATIVE HUMIDITY AT 0 °C, 25 °C, 85 °C



Humidity/Moisture Sensors

Humidity Sensor

HIH-3610 Series

ORDER GUIDE

Catalog Listing	Description
HIH-3610-001	Integrated circuit humidity sensor, 0.100 in lead pitch SIP
HIH-3610-002	Integrated circuit humidity sensor, 0.050 in lead pitch SIP
HIH-3610-003	Integrated circuit humidity sensor, 0.100 in lead pitch SIP with calibration and data printout
HIH-3610-004	Integrated circuit humidity sensor, 0.050 in lead pitch SIP with calibration and data printout

WARRANTY/REMEDY

Honeywell warrants goods of its manufacture as being free of defective materials and faulty workmanship. Contact your local sales office for warranty information. If warranted goods are returned to Honeywell during the period of coverage, Honeywell will repair or replace without charge those items it finds defective. The foregoing is Buyer's sole remedy and is in lieu of all other warranties, expressed or implied, including those of merchantability and fitness for a particular purpose.

Specifications may change without notice. The information we supply is believed to be accurate and reliable as of this printing. However, we assume no responsibility for its use.

While we provide application assistance personally, through our literature and the Honeywell web site, it is up to the customer to determine the suitability of the product in the application.

For application assistance, current specifications, or name of the nearest Authorized Distributor, check the Honeywell web site or call:

1-800-537-6945 USA

1-800-737-3360 Canada

1-815-235-6847 International

FAX

1-815-235-6545 USA

INTERNET

www.honeywell.com/sensing

info.sc@honeywell.com

FIGURE 4: MOUNTING DIMENSIONS (for reference only) mm (in)

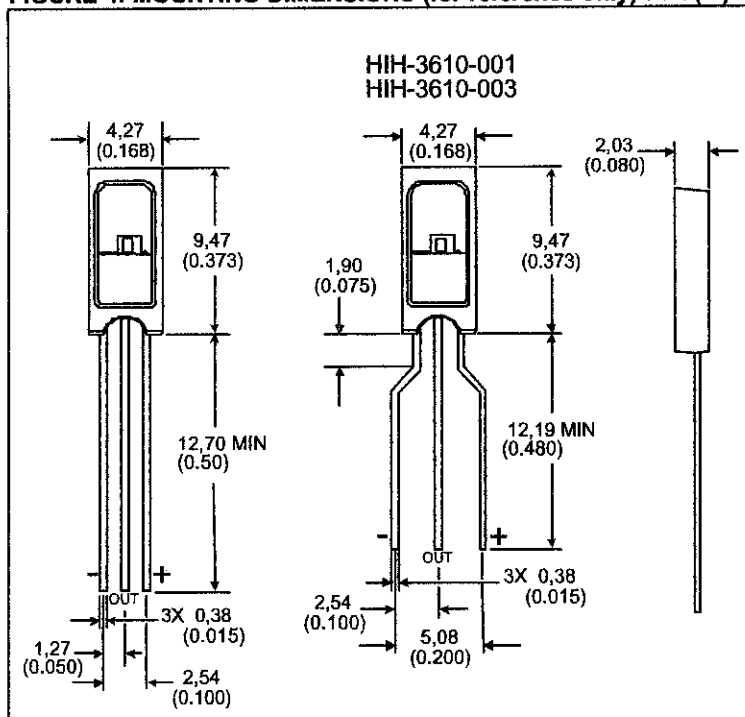

Honeywell

Sensing and Control
Honeywell
11 West Spring Street
Freeport, Illinois 61032



www.honeywell.com/sensing

Printed with Soy Ink
on 50% Recycled Paper

009012-1-EN IL50 GLO 600 Printed in USA

APPENDIX F

NPN SWITCHING TRANSISTOR DATASHEET

D A T A S H E E T

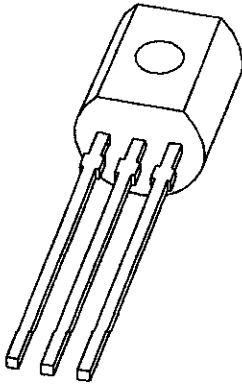

2N4401
NPN switching transistor

Product specification
Supersedes data of 1997 May 07

1999 Apr 23

NPN switching transistor

2N4401

FEATURES

- High current (max. 600 mA)
- Low voltage (max. 40 V).

APPLICATIONS

- Industrial and consumer switching applications.

DESCRIPTION

NPN switching transistor in a TO-92; SOT54 plastic package. PNP complement: 2N4403.

PINNING

PIN	DESCRIPTION
1	collector
2	base
3	emitter

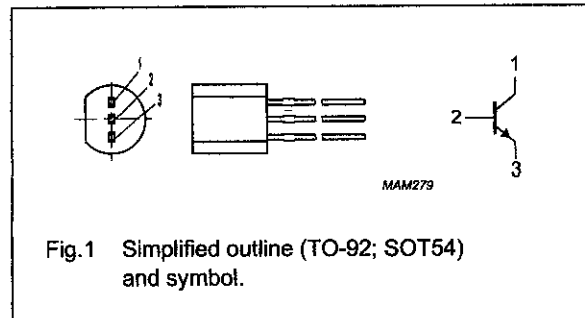

LIMITING VALUES

In accordance with the Absolute Maximum Rating System (IEC 134).

SYMBOL	PARAMETER	CONDITIONS	MIN.	MAX.	UNIT
V_{CBO}	collector-base voltage	open emitter	–	60	V
V_{CEO}	collector-emitter voltage	open base	–	40	V
V_{EBO}	emitter-base voltage	open collector	–	6	V
I_C	collector current (DC)		–	600	mA
I_{CM}	peak collector current		–	800	mA
I_{BM}	peak base current		–	200	mA
P_{tot}	total power dissipation	$T_{amb} \leq 25\text{ °C}$; note 1	–	630	mW
T_{stg}	storage temperature		–65	+150	°C
T_j	junction temperature		–	150	°C
T_{amb}	operating ambient temperature		–65	+150	°C

Note

1. Transistor mounted on an FR4 printed-circuit board.

NPN switching transistor

2N4401

THERMAL CHARACTERISTICS

SYMBOL	PARAMETER	CONDITIONS	VALUE	UNIT
$R_{th\ j-a}$	thermal resistance from junction to ambient	note 1	200	K/W

Note

1. Transistor mounted on an FR4 printed-circuit board.

CHARACTERISTICS

$T_j = 25\text{ }^\circ\text{C}$ unless otherwise specified.

SYMBOL	PARAMETER	CONDITIONS	MIN.	MAX.	UNIT
I_{CBO}	collector cut-off current	$I_E = 0; V_{CB} = 60\text{ V}$	–	50	nA
I_{EBO}	emitter cut-off current	$I_C = 0; V_{EB} = 6\text{ V}$	–	50	nA
h_{FE}	DC current gain	$V_{CE} = 1\text{ V}$; see Fig.2 $I_C = 0.1\text{ mA}$ $I_C = 1\text{ mA}$ $I_C = 10\text{ mA}$ $I_C = 150\text{ mA}$; note 1 $I_C = 500\text{ mA}$; $V_{CE} = 2\text{ V}$; note 1	20 40 80 100 40	– – – 300 –	
V_{CEsat}	collector-emitter saturation voltage	$I_C = 150\text{ mA}$; $I_B = 15\text{ mA}$; note 1 $I_C = 500\text{ mA}$; $I_B = 50\text{ mA}$; note 1	– –	400 750	mV mV
V_{BEsat}	base-emitter saturation voltage	$I_C = 150\text{ mA}$; $I_B = 15\text{ mA}$; note 1 $I_C = 500\text{ mA}$; $I_B = 50\text{ mA}$; note 1	– –	950 1.2	mV V
C_c	collector capacitance	$I_E = I_B = 0; V_{CB} = 5\text{ V}$; $f = 1\text{ MHz}$	–	6.5	pF
C_e	emitter capacitance	$I_C = I_C = 0; V_{EB} = 500\text{ mV}$; $f = 1\text{ MHz}$	–	30	pF
f_T	transition frequency	$I_C = 20\text{ mA}$; $V_{CE} = 10\text{ V}$; $f = 100\text{ MHz}$	250	–	MHz
Switching times (between 10% and 90% levels); see Fig.3					
t_{on}	turn-on time	$I_{Con} = 150\text{ mA}$; $I_{Bon} = 15\text{ mA}$; $I_{Boff} = -15\text{ mA}$	–	35	ns
t_d	delay time		–	15	ns
t_r	rise time		–	20	ns
t_{off}	turn-off time		–	250	ns
t_s	storage time		–	200	ns
t_f	fall time		–	60	ns

Note

1. Pulse test: $t_p \leq 300\text{ }\mu\text{s}$; $\delta \leq 0.02$.

NPN switching transistor

2N4401

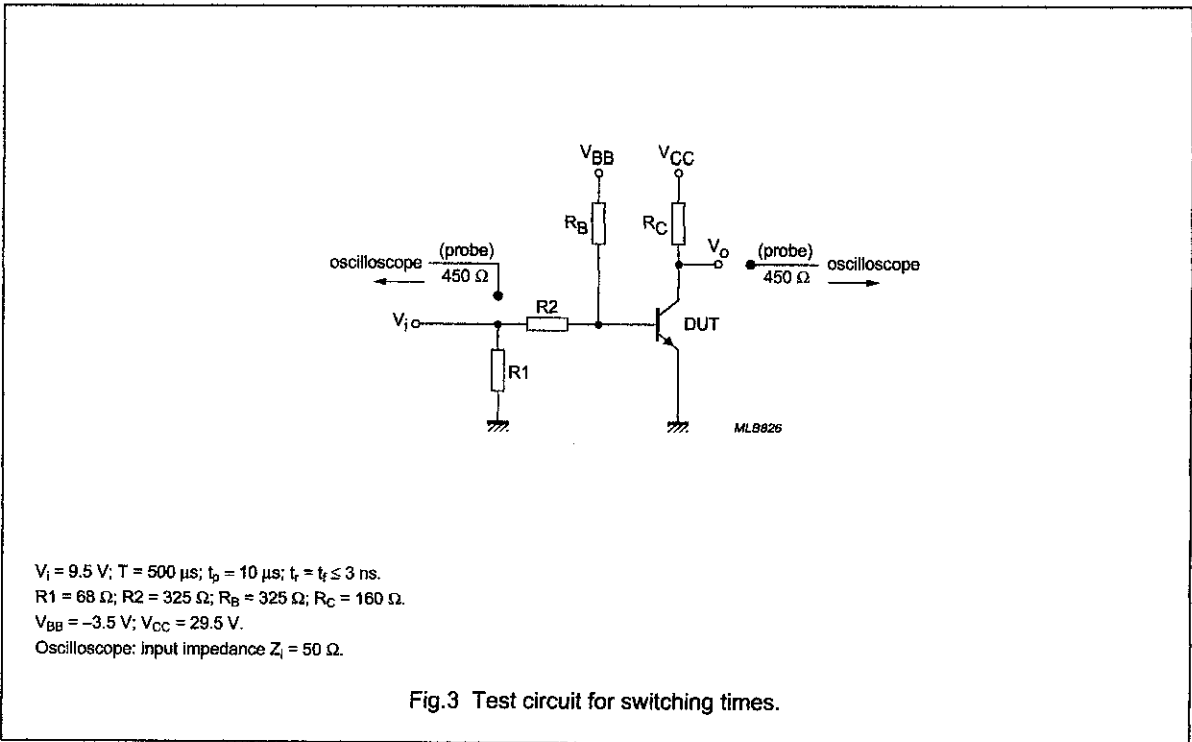
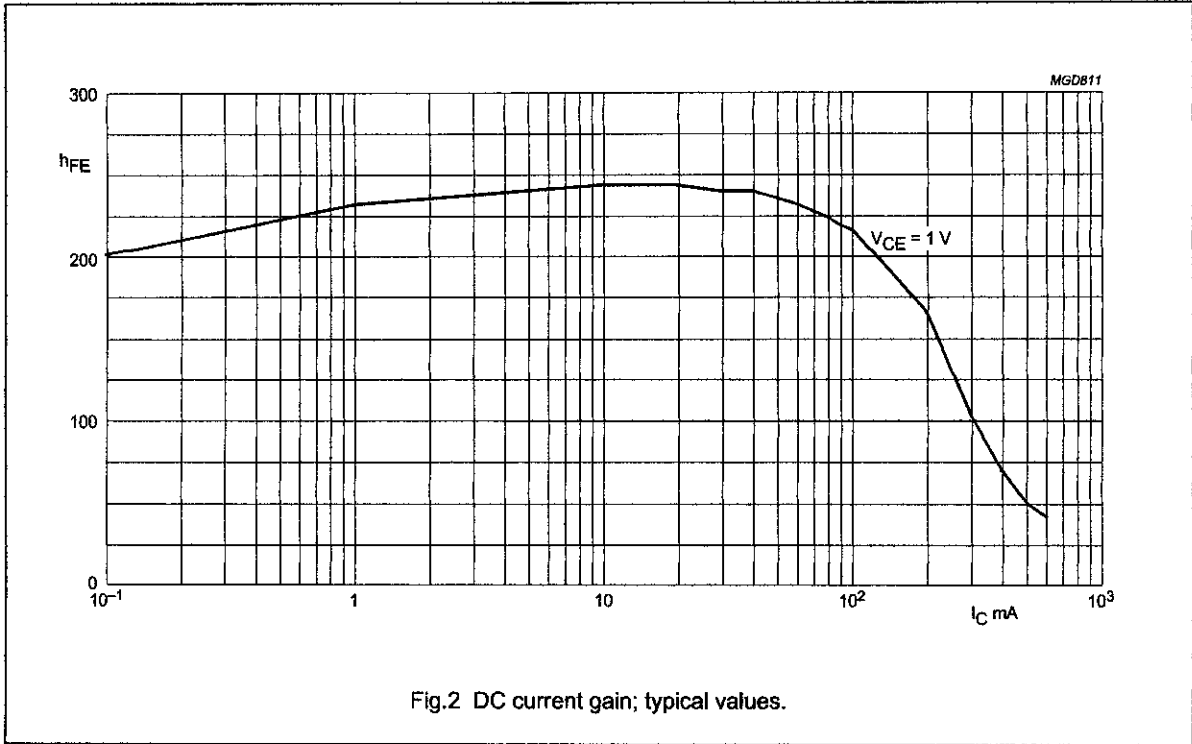

NPN switching transistor

2N4401

PACKAGE OUTLINE

Plastic single-ended leaded (through hole) package; 3 leads

SOT54

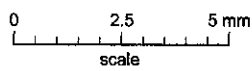
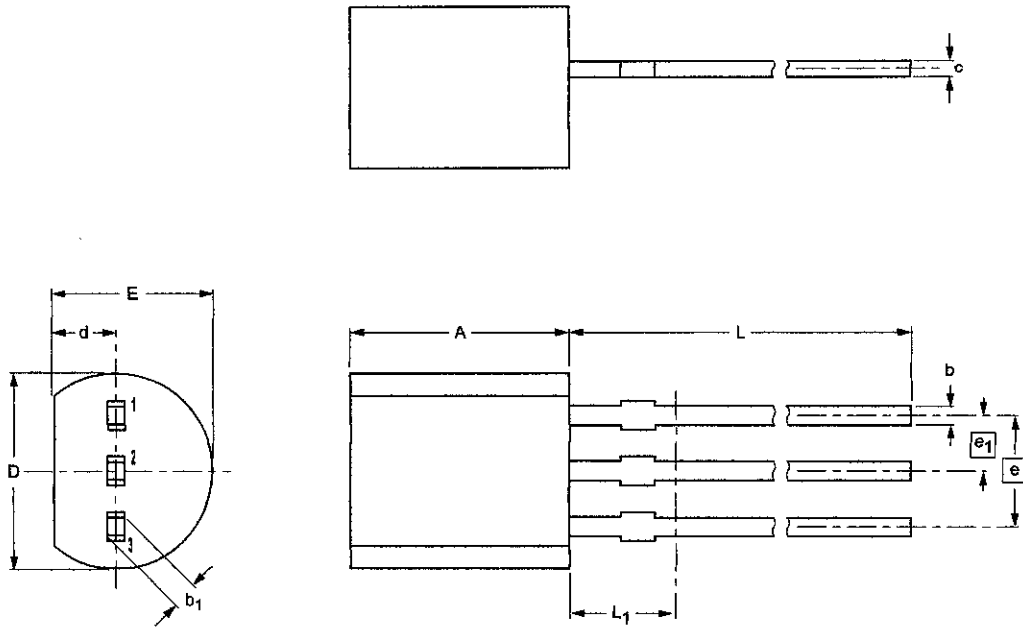

DIMENSIONS (mm are the original dimensions)

UNIT	A	b	b ₁	c	D	d	E	e	e ₁	L	L ₁ ⁽¹⁾
mm	5.2 5.0	0.48 0.40	0.66 0.56	0.45 0.40	4.8 4.4	1.7 1.4	4.2 3.6	2.54	1.27	14.5 12.7	2.5

Note

1. Terminal dimensions within this zone are uncontrolled to allow for flow of plastic and terminal irregularities.

OUTLINE VERSION	REFERENCES				EUROPEAN PROJECTION	ISSUE DATE
	IEC	JEDEC	EIAJ			
SOT54		TO-92	SC-43			97-02-28

NPN switching transistor

2N4401

DEFINITIONS

Data sheet status	
Objective specification	This data sheet contains target or goal specifications for product development.
Preliminary specification	This data sheet contains preliminary data; supplementary data may be published later.
Product specification	This data sheet contains final product specifications.
Limiting values	
Limiting values given are in accordance with the Absolute Maximum Rating System (IEC 134). Stress above one or more of the limiting values may cause permanent damage to the device. These are stress ratings only and operation of the device at these or at any other conditions above those given in the Characteristics sections of the specification is not implied. Exposure to limiting values for extended periods may affect device reliability.	
Application information	
Where application information is given, it is advisory and does not form part of the specification.	

LIFE SUPPORT APPLICATIONS

These products are not designed for use in life support appliances, devices, or systems where malfunction of these products can reasonably be expected to result in personal injury. Philips customers using or selling these products for use in such applications do so at their own risk and agree to fully indemnify Philips for any damages resulting from such improper use or sale.

APPENDIX G

TEMPERATURE SENSOR DATASHEET

LM35

Precision Centigrade Temperature Sensors

General Description

The LM35 series are precision integrated-circuit temperature sensors, whose output voltage is linearly proportional to the Celsius (Centigrade) temperature. The LM35 thus has an advantage over linear temperature sensors calibrated in ° Kelvin, as the user is not required to subtract a large constant voltage from its output to obtain convenient Centigrade scaling. The LM35 does not require any external calibration or trimming to provide typical accuracies of $\pm 1/4^\circ\text{C}$ at room temperature and $\pm 3/4^\circ\text{C}$ over a full -55 to $+150^\circ\text{C}$ temperature range. Low cost is assured by trimming and calibration at the wafer level. The LM35's low output impedance, linear output, and precise inherent calibration make interfacing to readout or control circuitry especially easy. It can be used with single power supplies, or with plus and minus supplies. As it draws only $60\ \mu\text{A}$ from its supply, it has very low self-heating, less than 0.1°C in still air. The LM35 is rated to operate over a -55° to $+150^\circ\text{C}$ temperature range, while the LM35C is rated for a -40° to $+110^\circ\text{C}$ range (-10° with improved accuracy). The LM35 series is available pack-

aged in hermetic TO-46 transistor packages, while the LM35C, LM35CA, and LM35D are also available in the plastic TO-92 transistor package. The LM35D is also available in an 8-lead surface mount small outline package and a plastic TO-220 package.

Features

- Calibrated directly in ° Celsius (Centigrade)
- Linear $+ 10.0\ \text{mV}/^\circ\text{C}$ scale factor
- 0.5°C accuracy guaranteeable (at $+25^\circ\text{C}$)
- Rated for full -55° to $+150^\circ\text{C}$ range
- Suitable for remote applications
- Low cost due to wafer-level trimming
- Operates from 4 to 30 volts
- Less than $60\ \mu\text{A}$ current drain
- Low self-heating, 0.08°C in still air
- Nonlinearity only $\pm 1/4^\circ\text{C}$ typical
- Low impedance output, $0.1\ \Omega$ for $1\ \text{mA}$ load

Typical Applications

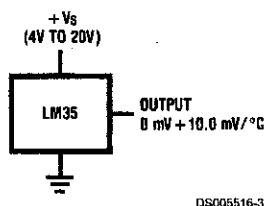
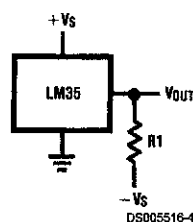

FIGURE 1. Basic Centigrade Temperature Sensor
($+2^\circ\text{C}$ to $+150^\circ\text{C}$)



Choose $R_1 = -V_S/60\ \mu\text{A}$
 $V_{\text{OUT}} = +1,500\ \text{mV}$ at $+150^\circ\text{C}$
 $= +250\ \text{mV}$ at $+25^\circ\text{C}$
 $= -550\ \text{mV}$ at -55°C

FIGURE 2. Full-Range Centigrade Temperature Sensor

Connection Diagrams

TO-46
Metal Can Package*

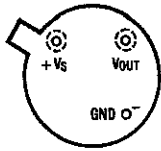

BOTTOM VIEW
DS005516-1

*Case is connected to negative pin (GND)

Order Number LM35H, LM35AH, LM35CH, LM35CAH or
LM35DH
See NS Package Number H03H

TO-92
Plastic Package

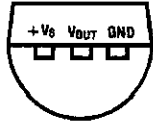

BOTTOM VIEW
DS005516-2

Order Number LM35CZ,
LM35CAZ or LM35DZ
See NS Package Number Z03A

SO-8
Small Outline Molded Package

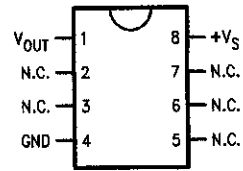

DS005516-21

N.C. = No Connection

Top View
Order Number LM35DM
See NS Package Number M08A

TO-220
Plastic Package*

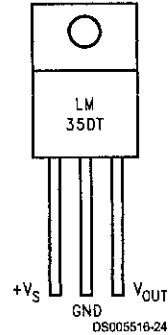

DS005516-24

*Tab is connected to the negative pin (GND).

Note: The LM35DT pinout is different than the discontinued LM35DP.

Order Number LM35DT
See NS Package Number TA03F

Absolute Maximum Ratings (Note 10)

Military/Aerospace specified devices are required, please contact the National Semiconductor Sales Office/ Distributors for availability and specifications.

Supply Voltage	+35V to -0.2V
Output Voltage	+6V to -1.0V
Output Current	10 mA
Storage Temp.:	
TO-46 Package,	-60°C to +180°C
TO-92 Package,	-60°C to +150°C
SO-8 Package,	-65°C to +150°C
TO-220 Package,	-65°C to +150°C
Lead Temp.:	
TO-46 Package, (Soldering, 10 seconds)	300°C

TO-92 and TO-220 Package, (Soldering, 10 seconds)	260°C
SO Package (Note 12)	
Vapor Phase (60 seconds)	215°C
Infrared (15 seconds)	220°C
ESD Susceptibility (Note 11)	2500V
Specified Operating Temperature Range: T_{MIN} to T_{MAX} (Note 2)	
LM35, LM35A	-55°C to +150°C
LM35C, LM35CA	-40°C to +110°C
LM35D	0°C to +100°C

Electrical Characteristics

(Notes 1, 6)

Parameter	Conditions	LM35A			LM35CA			Units (Max.)
		Typical	Tested Limit (Note 4)	Design Limit (Note 5)	Typical	Tested Limit (Note 4)	Design Limit (Note 5)	
Accuracy (Note 7)	$T_A = +25^\circ\text{C}$	± 0.2	± 0.5		± 0.2	± 0.5		$^\circ\text{C}$
	$T_A = -10^\circ\text{C}$	± 0.3			± 0.3		± 1.0	$^\circ\text{C}$
	$T_A = T_{MAX}$	± 0.4	± 1.0		± 0.4	± 1.0		$^\circ\text{C}$
	$T_A = T_{MIN}$	± 0.4	± 1.0		± 0.4		± 1.5	$^\circ\text{C}$
Linearity (Note 8)	$T_{MIN} \leq T_A \leq T_{MAX}$	± 0.18		± 0.35	± 0.15		± 0.3	$^\circ\text{C}$
Resistor Gain (Average Slope)	$T_{MIN} \leq T_A \leq T_{MAX}$	$+10.0$	$+9.9,$ $+10.1$		$+10.0$		$+9.9,$ $+10.1$	mV/ $^\circ\text{C}$
Load Regulation (Note 3) $0 \leq I_L \leq 1$ mA	$T_A = +25^\circ\text{C}$	± 0.4	± 1.0		± 0.4	± 1.0		mV/mA
	$T_{MIN} \leq T_A \leq T_{MAX}$	± 0.5		± 3.0	± 0.5		± 3.0	mV/mA
Line Regulation (Note 3)	$T_A = +25^\circ\text{C}$	± 0.01	± 0.05		± 0.01	± 0.05		mV/V
	$4\text{V} \leq V_S \leq 30\text{V}$	± 0.02		± 0.1	± 0.02		± 0.1	mV/V
Quiescent Current (Note 9)	$V_S = +5\text{V}, +25^\circ\text{C}$	56	67		56	67		μA
	$V_S = +5\text{V}$	105		131	91		114	μA
	$V_S = +30\text{V}, +25^\circ\text{C}$	56.2	68		56.2	68		μA
	$V_S = +30\text{V}$	105.5		133	91.5		116	μA
Change of Quiescent Current (Note 3)	$4\text{V} \leq V_S \leq 30\text{V}, +25^\circ\text{C}$	0.2	1.0		0.2	1.0		μA
	$4\text{V} \leq V_S \leq 30\text{V}$	0.5		2.0	0.5		2.0	μA
Temperature Coefficient of Quiescent Current		$+0.39$		$+0.5$	$+0.39$		$+0.5$	$\mu\text{A}/^\circ\text{C}$
Minimum Temperature Rated Accuracy	In circuit of <i>Figure 1</i> , $I_L = 0$	+1.5		+2.0	+1.5		+2.0	$^\circ\text{C}$
Long Term Stability	$T_J = T_{MAX}$, for 1000 hours	± 0.08			± 0.08			$^\circ\text{C}$

Electrical Characteristics

(Notes 1, 6)

Parameter	Conditions	LM35			LM35C, LM35D			Units (Max.)
		Typical	Tested Limit (Note 4)	Design Limit (Note 5)	Typical	Tested Limit (Note 4)	Design Limit (Note 5)	
Accuracy, LM35, LM35C (Note 7)	$T_A = +25^\circ\text{C}$	± 0.4	± 1.0		± 0.4	± 1.0		$^\circ\text{C}$
	$T_A = -10^\circ\text{C}$	± 0.5			± 0.5		± 1.5	$^\circ\text{C}$
	$T_A = T_{\text{MAX}}$	± 0.8	± 1.5		± 0.8		± 1.5	$^\circ\text{C}$
	$T_A = T_{\text{MIN}}$	± 0.8		± 1.5	± 0.8		± 2.0	$^\circ\text{C}$
Accuracy, LM35D (Note 7)	$T_A = +25^\circ\text{C}$				± 0.6	± 1.5		$^\circ\text{C}$
	$T_A = T_{\text{MAX}}$				± 0.9		± 2.0	$^\circ\text{C}$
	$T_A = T_{\text{MIN}}$				± 0.9		± 2.0	$^\circ\text{C}$
Nonlinearity (Note 8)	$T_{\text{MIN}} \leq T_A \leq T_{\text{MAX}}$	± 0.3		± 0.5	± 0.2		± 0.5	$^\circ\text{C}$
Sensor Gain (Average Slope)	$T_{\text{MIN}} \leq T_A \leq T_{\text{MAX}}$	+10.0	+9.8, +10.2		+10.0		+9.8, +10.2	mV/ $^\circ\text{C}$
Load Regulation (Note 3) $0 \leq I_L \leq 1 \text{ mA}$	$T_A = +25^\circ\text{C}$	± 0.4	± 2.0		± 0.4	± 2.0		mV/mA
	$T_{\text{MIN}} \leq T_A \leq T_{\text{MAX}}$	± 0.5		± 5.0	± 0.5		± 5.0	mV/mA
Line Regulation (Note 3)	$T_A = +25^\circ\text{C}$	± 0.01	± 0.1		± 0.01	± 0.1		mV/V
	$4\text{V} \leq V_S \leq 30\text{V}$	± 0.02		± 0.2	± 0.02		± 0.2	mV/V
Quiescent Current (Note 9)	$V_S = +5\text{V}, +25^\circ\text{C}$	56	80		56	80		μA
	$V_S = +5\text{V}$	105		158	91		138	μA
	$V_S = +30\text{V}, +25^\circ\text{C}$	56.2	82		56.2	82		μA
	$V_S = +30\text{V}$	105.5		161	91.5		141	μA
Change of Quiescent Current (Note 3)	$4\text{V} \leq V_S \leq 30\text{V}, +25^\circ\text{C}$	0.2	2.0		0.2	2.0		μA
	$4\text{V} \leq V_S \leq 30\text{V}$	0.5		3.0	0.5		3.0	μA
Temperature Coefficient of Quiescent Current		+0.39		+0.7	+0.39		+0.7	$\mu\text{A}/^\circ\text{C}$
Minimum Temperature for Rated Accuracy	In circuit of <i>Figure 1</i> , $I_L = 0$	+1.5		+2.0	+1.5		+2.0	$^\circ\text{C}$
Long Term Stability	$T_J = T_{\text{MAX}}$, for 1000 hours	± 0.08			± 0.08			$^\circ\text{C}$

Note 1: Unless otherwise noted, these specifications apply: $-55^\circ\text{C} \leq T_J \leq +150^\circ\text{C}$ for the LM35 and LM35A; $-40^\circ\text{C} \leq T_J \leq +110^\circ\text{C}$ for the LM35C and LM35CA; and $0^\circ\text{C} \leq T_J \leq +100^\circ\text{C}$ for the LM35D. $V_S = +5\text{Vdc}$ and $I_{\text{LOAD}} = 50 \mu\text{A}$, in the circuit of *Figure 2*. These specifications also apply from $+2^\circ\text{C}$ to T_{MAX} in the circuit of *Figure 1*. Specifications in **boldface** apply over the full rated temperature range.

Note 2: Thermal resistance of the TO-46 package is $400^\circ\text{C}/\text{W}$, junction to ambient, and $24^\circ\text{C}/\text{W}$ junction to case. Thermal resistance of the TO-92 package is $180^\circ\text{C}/\text{W}$ junction to ambient. Thermal resistance of the small outline molded package is $220^\circ\text{C}/\text{W}$ junction to ambient. Thermal resistance of the TO-220 package is $90^\circ\text{C}/\text{W}$ junction to ambient. For additional thermal resistance information see table in the Applications section.

Note 3: Regulation is measured at constant junction temperature, using pulse testing with a low duty cycle. Changes in output due to heating effects can be computed by multiplying the internal dissipation by the thermal resistance.

Note 4: Tested Limits are guaranteed and 100% tested in production.

Note 5: Design Limits are guaranteed (but not 100% production tested) over the indicated temperature and supply voltage ranges. These limits are not used to calculate outgoing quality levels.

Note 6: Specifications in **boldface** apply over the full rated temperature range.

Note 7: Accuracy is defined as the error between the output voltage and $10\text{mV}/^\circ\text{C}$ times the device's case temperature, at specified conditions of voltage, current, and temperature (expressed in $^\circ\text{C}$).

Note 8: Nonlinearity is defined as the deviation of the output-voltage-versus-temperature curve from the best-fit straight line, over the device's rated temperature range.

Note 9: Quiescent current is defined in the circuit of *Figure 1*.

Note 10: Absolute Maximum Ratings indicate limits beyond which damage to the device may occur. DC and AC electrical specifications do not apply when operating the device beyond its rated operating conditions. See Note 1.

Note 11: Human body model, 100 pF discharged through a $1.5 \text{ k}\Omega$ resistor.

Note 12: See AN-450 "Surface Mounting Methods and Their Effect on Product Reliability" or the section titled "Surface Mount" found in a current National Semiconductor Linear Data Book for other methods of soldering surface mount devices.

Typical Performance Characteristics

Thermal Resistance Junction to Air

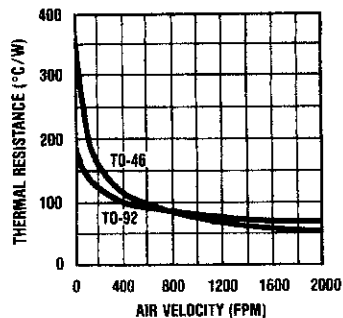

DS005516-25

Thermal Time Constant

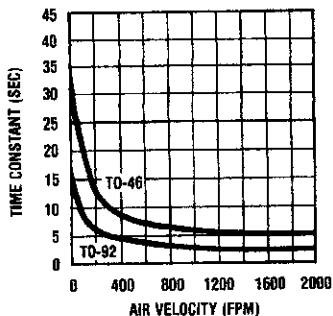

DS005516-26

Thermal Response in Still Air

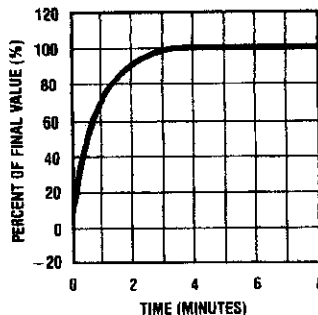

DS005516-27

Thermal Response in Stirred Oil Bath

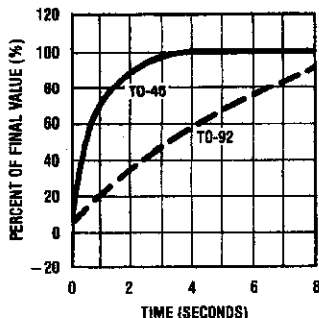

DS005516-28

Minimum Supply Voltage vs. Temperature

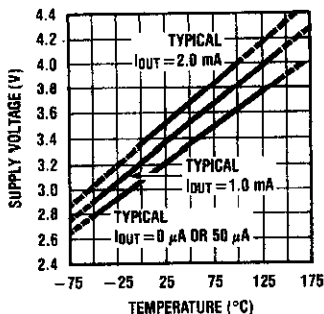

DS005516-29

Quiescent Current vs. Temperature (In Circuit of Figure 1.)

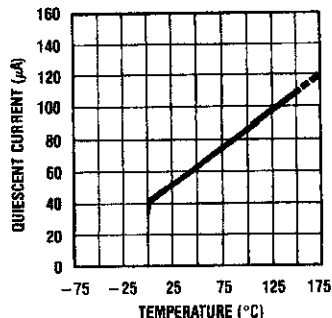

DS005516-30

Quiescent Current vs. Temperature (In Circuit of Figure 2.)

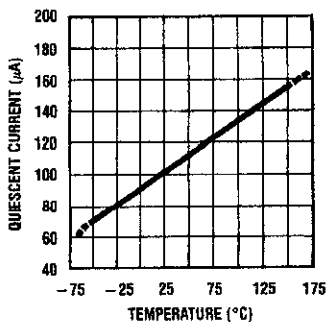

DS005516-31

Accuracy vs. Temperature (Guaranteed)

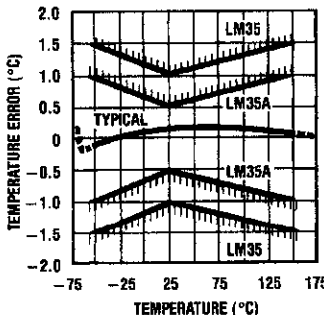

DS005516-32

Accuracy vs. Temperature (Guaranteed)

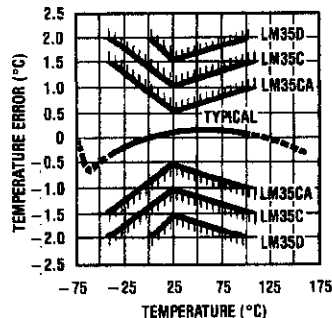

DS005516-33