



UWS Academic Portal

ADD-Net

Sadiq Fareed, Mian Muhammad; Zikria, Shahid; Ahmed, Gulnaz; Mui-zzud-din; Mahmood, Saqib; Aslam, Muhammad; Jillani, Syeda Fizzah; Moustafa, Ahmad; Asad, Muhammad

Published in:
IEEE Access

DOI:
[10.1109/ACCESS.2022.3204395](https://doi.org/10.1109/ACCESS.2022.3204395)

E-pub ahead of print: 05/09/2022

Document Version
Publisher's PDF, also known as Version of record

[Link to publication on the UWS Academic Portal](#)

Citation for published version (APA):

Sadiq Fareed, M. M., Zikria, S., Ahmed, G., Mui-zzud-din, Mahmood, S., Aslam, M., Jillani, S. F., Moustafa, A., & Asad, M. (2022). ADD-Net: an effective deep learning model for early detection of Alzheimer Disease in MRI scans. *IEEE Access*, *10*, 96930-96951. <https://doi.org/10.1109/ACCESS.2022.3204395>

General rights

Copyright and moral rights for the publications made accessible in the UWS Academic Portal are retained by the authors and/or other copyright owners and it is a condition of accessing publications that users recognise and abide by the legal requirements associated with these rights.

Take down policy

If you believe that this document breaches copyright please contact pure@uws.ac.uk providing details, and we will remove access to the work immediately and investigate your claim.

Date of publication xxxx 00, 0000, date of current version xxxx 00, 0000.

Digital Object Identifier 10.1109/ACCESS.2017.DOI

ADD-Net: An Effective Deep Learning Model for Early Detection of Alzheimer Disease in MRI Scans

MIAN MUHAMMAD SADIQ FAREED¹, SHAHID ZIKRIA², GULNAZ AHMED³, MUI-ZZUD-DIN⁴, SAQIB MAHMOOD², MUHAMMAD ASLAM⁵, SYEDA FIZZAH JILLANI⁶, AHMAD MOSTAFA⁷ AND MUHAMMAD ASAD⁷

¹Department of Software Engineering, University of Central Punjab, Lahore, Pakistan

²Department of Computer Science, Khwaja Fareed University of Engineering and Information Technology, Rahim yar Khan, Pakistan

³Department of Computer Science, ILMA University, Karachi, Pakistan

⁴Department of Computer Science, Ghazi University 32200, Dera Ghazi Khan, Pakistan

⁵School of Computing Engineering and Physical Sciences, University of West of Scotland, UK

⁶Department of Physics, Physical Sciences Building, Aberystwyth University, Aberystwyth, UK

⁷Department of Computer Science, Nagoya Institute of Technology, Nagoya, Japan

Corresponding author: Gulnaz Ahmed (e-mail: gulnaz@xjtu.edu.cn), Muhammad Aslam (e-mail: muhammad.aslam@uws.ac.uk)

ABSTRACT Alzheimer's Disease (AD) is a neurological brain disorder marked by dementia and neurological dysfunction that affects memory, behavioral patterns, and reasoning. Alzheimer's disease is an incurable disease that primarily affects people over the age of 40. Presently, Alzheimer's disease is diagnosed through a manual evaluation of a patient's MRI scan and neuropsychological examinations. Deep Learning (DL), a type of Artificial Intelligence (AI), has pioneered new approaches to automate medical image diagnosis. The goal of this study is to create a reliable and efficient approach for classifying AD using MRI by applying the deep Convolutional Neural Network (CNN). In this paper, we propose a new CNN architecture for detecting AD with relatively few parameters and the proposed solution is ideal for training a smaller dataset. This proposed model successfully distinguishes the early stages of Alzheimer's disease and shows class activation maps as a heat map on the brain. The proposed Alzheimer's Disease Detection Network (ADD-Net) is built from scratch to precisely classify the stages of AD by decreasing parameters and calculation costs. The Kaggle MRI image dataset has a significant class imbalance problem and we exploited a synthetic oversampling technique to evenly distribute the image among the classes to prevent the problem of class imbalance. The proposed ADD-Net is extensively evaluated against DenseNet169, VGG19, and InceptionResNet V2 using precision, recall, F1-score, Area Under the Curve (AUC), and loss. The ADD-Net achieved the following values for evaluation metrics: 98.63%, 99.76%, 98.61%, 98.63%, 98.58%, and 0.0549 for accuracy, AUC, F1-score, precision, recall, and loss, respectively. From the simulation results, it is noted that the proposed ADD-Net outperforms other state-of-the-art models in all the evaluation metrics.

INDEX TERMS Deep Learning, Image Classification, Supervised Learning, Transfer Learning, Imbalanced Data-set, MRI Data-set, Computer-Aided Diagnosis, SMOTETOMEK, Class Activation.

I. INTRODUCTION

Alzheimer's Disease (AD) is the most frequent kind of dementia that needs substantial medical attention. Early and precise analysis of AD prognosis is required for the start of therapeutic progress and efficient patient therapy [1]. According to a study, 10 million new cases of dementia are registered every year [2]. The World Health Organization (WHO) reported that AD has surpassed cancer as the fifth biggest cause of death, with the number of AD patients expected to reach

152 million by 2050 [2]. AD is a long-term neurological brain disease that gradually destroys brain cells, causing memory loss and cognitive problems, and finally accelerating the loss of ability to perform day-to-day activities of real-life [3].

AD is a brain-neurological degeneration disorder [4]. It is categorized as dementia, atrophy of the human brain affecting memory, and causes loss of behavioral, social, and reasoning faculties. It is caused by the accumulation of protein fragments in the brain [5]–[7]. Plaques and tangles

are formed around the neurons inside the human brain which results in abnormal shrinking of lobes and hippocampus, and enlarged ventricles [8]. It is an incurable fatal disease [9], [10] with a lifetime of agony for the patient and a severe mental, physical, and financial toll of suffering for the family of the patient. The cause of AD is unknown, and there are no effective medications or therapies to reverse dementia. Mild Cognitive Impairment (MCI) a pre-clinical stage of AD is a transitory state between normal ageing and AD.

Detecting the risk and severity of AD at its early stages is very critical [11], [12]. However, Doctors can classify AD in its early stages using neuro-imaging and computer-assisted diagnostic approaches with very less accuracy. Neuro-imaging including Computed Tomography (CT) scan, Positron Emission Tomography (PET) scan, and specifically Magnetic Resonance Imaging (MRI) scan play a vital role in medical diagnosis [4]. It is a significant non-invasive method that provides information about the human body. The advancement of the medical diagnosis process has created tremendous research trends in computer-aided diagnosis nowadays [5], [6].

Over the years, numerous Machine Learning (ML) [13] and Deep Learning (DL) [14] algorithms have been developed by many researchers around the globe for AD detection and classification. Many researchers have achieved remarkable results using the DL algorithms, however, there is still room for improvement. In this series of DL models, a hybrid Convolutional Neural Network (CNN), a CNN model with slice selection, and a CNN model with histogram stretching is introduced in [15]–[17]. Others proposed a CNN model with skull stripping [18] and a CNN model which utilized the slicing samples for pre-processing is introduced in [19]. However, the focus of these deep models is mostly biased towards classification due to the black-box nature of CNN.

In the literature on AD, some researchers have developed miscellaneous tools and applications for automated segmentation of neuro-images [20]. These applications are Vol-Brain [21], and Fusion of neuro-imaging Pre-processing [22]. Although these applications are effective tools for the segmentation of neuro-image, however, the research focused on visualizing the classification process through CNN layers is scarce. The feature map of each convolution layer reveals various filters being applied to the image and it provides a hint to what sort of filters the model is applying to the image for feature extraction [23]. This approach supports grad-CAM [24] heat-map which shows class activation via gradient-based localization map.

The proposed CNN model uses a series of conventional blocks which consist of different deep layers to accomplish the outstanding classification results. The goal of the proposed ADD-Net is to obtain an accurate classification result for the detection of AD in its earlier stages with better accuracy. The main contributions of the research study are:

- We propose a new convolutional neural network architecture for detecting AD with relatively few parameters

and the proposed solution is ideal for training a smaller dataset.

- The previous methods [22], [23], [25] accuracy compromised on Alzheimer's data-set due to an imbalanced number of classes. To handle the imbalance problem of the Alzheimer's data-set, we exploited the SMOTE-TOMEK oversampling algorithm which interpolates new images to balance the class samples.
- In our proposed model, we used the Grad-CAM to show and highlight the infected part of the brain for different stages of Alzheimer's disease and the generated heat map intensities highlight the severity of each stage very clearly.
- The proposed model is extensively compared with several other approaches using various evaluation parameters: Accuracy, AUC, Precision, Recall, F1-score, and size of trainable parameters. It is observed that our approach outperforms other state-of-the-art models.

The rest of the paper is arranged in the following way: The related studies of the proposed model are briefed in section II. The methodology and proposed ADD-Net model for AD classification details are presented with the description of the data-set and model components are presented in section III. The visualization process and the ADD-Net model evaluation with the state-of-the-art models are presented in section IV. The limitations and the conclusion of the ADD-Net with future goals is described in section V and section VI, respectively.

II. RELATED WORK

Precise classification of medical images is a strenuous task because of the difficult procedure of obtaining medical data-sets [25]. Unlike other data-sets, medical data-sets are prepared by expert specialists and contain sensitive and private information of patients which cannot be publicly disclosed to anyone. That is why organizations and institutions like Alzheimer's Disease Neuro-imaging Initiative (ADNI) [26] and Open Access Series of Imaging Studies (OASIS) [27] providing medical data-sets have a screening process for accessing their data-sets which requires an application to be filled and terms to be agreed by the researcher, constraining them from using it for research purposes only [28]–[32]. Medical data-sets are inherently highly imbalanced because it is impossible to compile a data-set with an equal number of samples of patients with health and ailment, and the techniques to tackle this problem are quite challenging themselves [33]–[36]. OASIS data-set containing 416 3D samples is used by Jyoti et al. [37] to create a CNN model with the convolution layer, batch normalization layer, pooling layer, and Adam optimizer.

The authors compared their model with two different pre-trained architectures like InceptionV4 [38] and ResNet [39] to evaluate their model accuracy. A cost-sensitive training technique is used to overcome the data-set imbalance problem is discussed in [40]. The cost matrix modified the result of the output layer to give more importance to classes with

TABLE 1: A literature evaluation of numerous recent cutting-edge approaches used in AD detection and classification.

Approach	Year	Method	Results					Modalities	Imbalance Handling
			Accuracy	AUC	Precision	Recall	F1-Score		
Shereen [29]	2021	DenseNet201, ResNet101	94.86%	-	89.47%	83.74%	95.36%	4	None
Badiea [53]	2021	AlexNet + SVM & AlexNet + ResNet50	94.8%	99.7%	-	-	-	2	None
Pradhan [32]	2021	DenseNet169 & VGG19	82.6%	86.7%	-	-	-	2	None
Vasukidevi [55]	2021	CapsNet	94.3%	-	94.92%	95.89%	95.19%	1	None
Battineni [34]	2021	CNN Model	83.3%	-	-	-	-	1	None
Suganthe [16]	2021	Inception-ResNet-v2	79.12%	81.9%	70.64%	28.22%	39.91%	1	None
Jyoti [56]	2018	InceptionV4 + ResNet + ADNet	93.18%	-	94%	93%	92%	5	Data Augmentation
Jyoti [57]	2017	DenseNet121 + DenseNet161 + DenseNet169	93.18%	-	94%	93%	92%	4	None
Jyoti [57]	2017	InceptionV4	73.75%	-	-	-	-	1	None

fewer samples and the experiments achieved a precision of 75%. A comparative analysis of state-of-the-art Alzheimer's disease classification models is depicted in Table 1, we can note that the traditional deep and transfer learning models achieve good accuracy on the imbalance datasets.

A similar approach is adopted by Hussain et al. [41] for the same OASIS data-set. They used a 12-layer CNN architecture including convolution and pooling operations. They used Leaky ReLU [42] in combination with MaxPooling as activation function instead of ReLU [43] to avoid gradient vanishing issue [44]. The authors compared their model with four different pre-trained models like InceptionV3, Xception [45], MobileNetV2 [46], and VGG19 [25] to analyze the performance of the model. The model achieves an accuracy of 97.75% during experiments in comparison with pre-trained models.

The same data-set from Kaggle is used by Suganthe et al. [14] to implement a hybrid framework using ResNet V2 with Inception V4. In this model, the ResNet V2 integrates residual connections to the pre-trained Inception V4 model [41]. In the experiments, the model is assessed by varying learning rates and optimizer, and the highest accuracy of 79.12% is produced by the model. A simple comparative study is performed by Pradhan et al. [32] using two state-of-the-art pre-trained models like VGG19 and DenseNet169 [47]. These two models are selected due to the ability of VGG19 to train on a large number of classes with remarkable accuracy and the DenseNet169 can handle vanishing gradient issues and reduce the number of training parameters. The data-set from Kaggle was fed to both models via Image Data Generator (IDG) with different augmentation parameters. Through the augmentation both the pre-trained models like VGG19 and DenseNet169 achieved an accuracy of 88% and 87%, respectively. Battineni et al. [34] employed an

OASIS-3 data-set and created a five-layer CNN model for the classification of three different early stages of Alzheimer's disease [48].

Not all the features extracted by a deep model are useful in accurately predicting the correct class of a sample and some features hinder a model from reaching desired results [49], [50]. This issue of deep models was tackled by El-Aal et al. [29] and presented a novel approach to selecting specific features from the feature map of deep models which ultimately improves the classification results and reduces the training time of the model. The ResNet101 and DenseNet201 for feature extraction while the Rival Genetic Algorithm (RGA) [51] and Probability Binary Particle Swarm Optimization (PBPSO) [52] algorithms were used for feature selection. The selected features and control features were fed to a separately created classification model. ResNet101 and DenseNet201 provided the best results with PBPSO and achieved an accuracy of 87.3% and 94.8%, respectively. Raju et al. [53]–[55], [58], [59] utilized a class activation heat-map algorithm named Grad-CAM, which uses gradient data for its calculations, and heat-maps to help in understanding the working of a deep model. They selected a transfer learning approach for training a deep model and modified the VGG16 by adding an extra dense layer at the end of the model. The performance of the model is enhanced by Fastai [54], [58]–[61] using the grad-CAM to highlight the regions of the brain on MRI samples that are selected by the previous model for making predictions. SGD loss function in combination with Nesterov intensity [55], [59]–[61] further improved the classification results and the model attained a test accuracy of 97.89%.

The proposed model differs from other recently proposed methods in two ways:

- Firstly, a few researchers have used data augmentation

techniques to improve their results. In contrast, none of the reviewed research papers regarding the classification of Alzheimer's disease has recognised the major problem of data-set imbalance. Our proposed model is oversampling the dataset by generating synthetic samples using SMOTETOMEK.

- Secondly, the previous models are trained using transfer learning containing many parameters affecting the network's efficiency. In contrast, the proposed model is built from scratch to precisely classify the stages of AD by decreasing parameters and calculation costs.

In DL, there is always scope for improvement and most of the researchers have not been able to achieve remarkable classification performance. Their methodologies and approaches suffer from various hindering factors because they have overlooked some inherent hurdles of DL models and medical image data-set [5], [12], [23]. The data-set used in this research is collected from Kaggle which contains 6400 samples of anonymous patients with only MRI scan images and their respective class labels information. It is a multi-class data-set consisting of four different classes including a normal (NOD) class and three other classes representing three different early stages of AD namely, Very Mild Demented (VMD), Mild Demented (MD), and Moderate Demented (MOD). It is two years old data-set and various researchers have offered their contributions in this duration while obtaining good results by employing a number of techniques and their combinations.

III. THE PROPOSED ADD-NET MODEL FOR EARLY ALZHEIMER DIAGNOSIS

In the medicine and healthcare field, image processing has brought quite a revolution. Nowadays, image processing has applications in almost every aspect of the medical field. It is possible for doctors to examine the organs of the human body from the inside without the need for surgery during the diagnosis stage. There are various types of scans in the medical field: X-Ray, Ultrasound, Magnetic Resonance Imaging (MRI), and Computed Tomography (CT) scans. A human being cannot possibly examine medical scans as precisely as a machine is capable and draw accurate conclusions from them. A machine trained on a medical image data-set is fully capable of providing accurate results within seconds whereas, on the other hand, it might take a whole panel of doctors to derive the same conclusion in days. The modern health care systems depend upon computer vision and image processing algorithms as their integral part. The importance cannot be overstated. AD is becoming one of the most rapidly increasing diseases globally. A few researchers have used data augmentation techniques to improve their results, while none of the reviewed research papers regarding the classification of Alzheimer's disease has recognized the imbalance data-set issue. There are still some researchers who failed to obtain notable results because they did not train their models enough. It is observed that research papers

focus on discovering new approaches toward classification purposes for biomedical diagnoses.

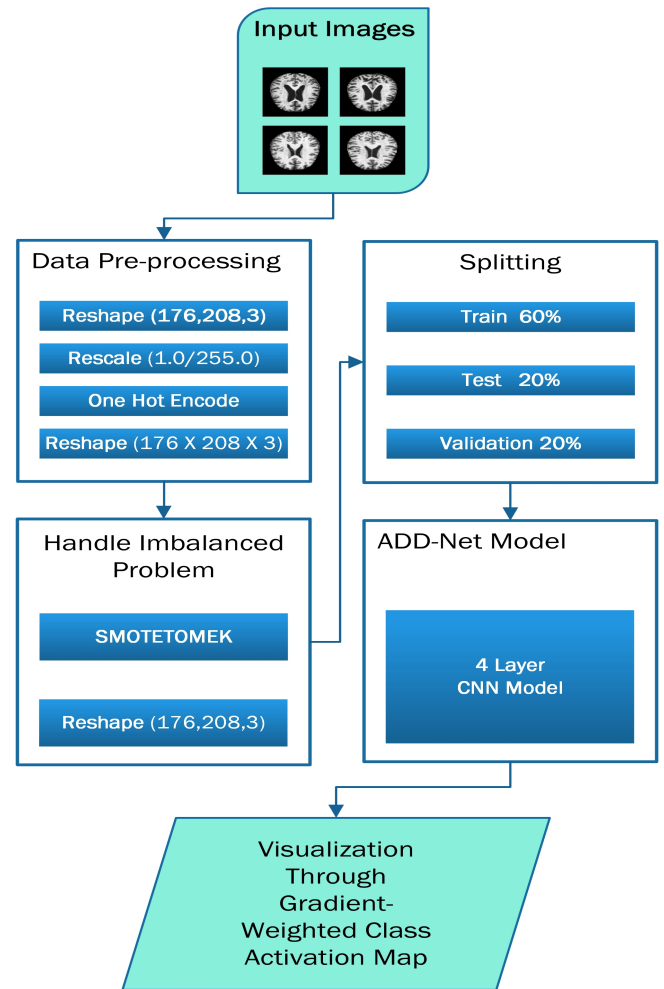

FIGURE 1: The methodology of the proposed ADD-Net for early detection of AD.

In this proposed model, the input data-set is pre-processed using normalization and the essential process of converting the categorical data variables to be provided to the ADD-Net using the one-hot encoder. Then, the Synthetic Minority Oversampling Technique (SMOTETOMEK) algorithm is utilized to solve the imbalanced data-set issue that over-samples the classes to balance the data-set. Afterwards, the data set is split into train, test, and validation by 60%, 20%, and 20%, respectively. Furthermore, the features are extracted using a standard CNN for effectively training the ADD-Net as shown in Fig.1. The size of training parameters is smaller in comparison with [29], [32], [34] for the robustness of the model in AD classification. The Grad-CAM heat-map algorithm is utilized to visualize the class activation map which highlights the features which lead to the classification of an image sample.

A. DESCRIPTION OF THE AD DATASET

There is a number of data sets available on the internet for AD classification. Many AD data sets are in CSV format and are not suitable for this research. Dedicated organizations like ADNI and OASIS also provide access to their data sets for research and educational purposes. However, the samples in both of these data sets are in 3-Dimensional image format and the size of the data sets is gigantic. The OASIS data set is 18 gigabytes while the ADNI dataset is 450 gigabytes. The data set used in this research is collected from Kaggle which contains samples of anonymous patients with only MRI scan images and their respective class labels information. It is a multi-class data set consisting of different views and four different classes including a normal NOD class and three other classes representing three different early stages of AD namely, VMD, MD, and MOD are slightly observable with the bare eye in Fig. 2.

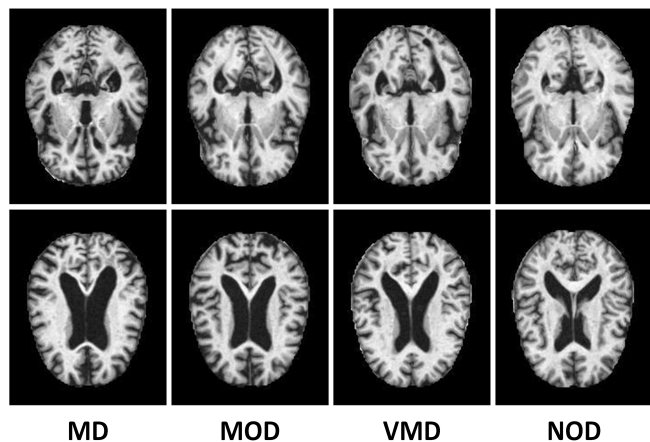

FIGURE 2: The image samples from AD dataset without up-sampling through SMOTETOMEK.

According to the description of the data set, each sample in the data set available on Kaggle is personally verified by the uploader himself. Also, the size of the data set is reasonable and the samples are already cleaned up i.e., resized and organized. Based on these factors, this data set is used in our research. The data set has 6400 samples in total. The samples are individual three-channel (RGB) images of 176 x 208 pixels dimension belonging to four different classes. The number of samples in the NOD class is 3200. The remaining three classes, VMD, MD, and MOD have 2240, 896, and 64 images, respectively. The only downside of this data-set is that it is imbalanced as discussed in Table 2. To solve this problem, we use SMOTETOMEK to generate synthetic data for each imbalance class with respect to the balanced class as shown in Fig. 2. The data set is divided into 60%, 20%, and 20% for training, validation, and test set, respectively.

1) Balancing the AD Dataset using SMOTETOMEK

Typically, oversampling and under-sampling are two techniques for re-sampling. However, another type of re-

TABLE 2: AD data-set class distribution before up-sampling through SMOTETOMEK.

Class	No. of Images
Mild Demented (MD)	896
Moderate Demented (MOD)	64
Non-Demented (NOD)	3200
Very Mild Demented (VMD)	2240

sampling approach exists that is a hybrid of both methods. For this research study, we have employed the hybrid SMOTETOMEK algorithm. It combines SMOTE, the up-sampling algorithm, and TOMEK, the downsampling method. SMOTE generates new samples relying on class nearest neighbours, while TOMEK is an implementation of condensed nearest neighbours. Both algorithms work in sequence and SMOTE chooses a random instance from a minority class and increases its proportion by interpolating new samples. TOMEK then selects a random sample and discards it if its nearest neighbours belong to the minority class. In this way, SMOTETOMEK evens the samples of each class and effectively solves the dataset imbalance problem as depicted in Table 3. To balance out the data set, SMOTETOMEK utilizes the Nearest Neighbor technique to interpolate new imitation samples for the minority classes shown in Fig. 3.

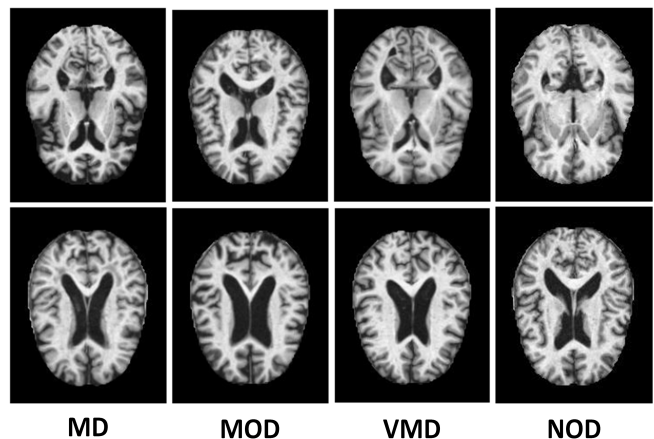

FIGURE 3: The synthetic image samples generated through SMOTETOMEK for all classes.

TABLE 3: AD data-set class distribution after up-sampling through SMOTETOMEK.

Class	No. of Images
Mild Demented (MD)	3200
Moderate Demented (MOD)	3200
Non-Demented (NOD)	3200
Very Mild Demented (VMD)	3200

B. ADD-NET MODEL COMPONENTS

The main components of the proposed model are briefly discussed in the next subsections.

1) The Proposed ADD-Net Network Architecture

The CNN architecture is based on the biological structure of the human brain and it is particularly used in computer vision applications like image classification, image segmentation, and object detection. Previously designed deep models preferred it due to its translation-invariant nature [51]. The translation or space invariance implies that a CNN is able to recognize the same feature regardless of its position in various images. In this paper, we proposed a novel CNN model from scratch to perform accurate AD classification. The proposed ADD-Net is comprised of four convolutional

TABLE 4: The total parameters for the proposed ADD-Net model.

Model Summary		
Layer Type	Output Shape	Parameters
Input Layer	(None, 176, 208, 3)	0
ADD-NET Block01	(None, 86, 102, 16)	1216
ADD-NET Block02	(None, 41, 49, 32)	12832
ADD-NET Block03	(None, 18, 22, 64)	51264
ADD-NET Block04	(None, 7, 9, 128)	204928
Dropout_1	(None, 7, 9, 128)	0
Flatten	(None, 8064)	0
Dense_1	(None, 256)	2064640
Dropout_2	(None, 256)	0
Dense_2	(None, 4)	1028
Output: SOFTMAX	(None, 4)	0
Total Parameters		23,35,908
Trainable Parameters		23,35,909
Non-Trainable Parameters		0

blocks and each convolutional block has a Rectified Linear Unit (ReLU) activation function and a 2D average pooling layer, two dropout layers, two dense layers, and a SoftMax classification layer as depicted in Fig. 4. The detailed network architecture and model summary of the proposed model used for the classification of AD with the subsequent layer is discussed in Table 4, and description of hyper-parameters that plays an important role in effective training of ADD-Net model in Table 5.

TABLE 5: List of hyper parameters that are used in ADD-Net architecture.

Sr.#	Parameter Name	Parameter Type
1	Optimizer	SGD
2	Learning rate	0.01
3	Batch size	8
4	Epochs	40
5	Call back	ReduceLRonPlateau
6	Hidden layer activation	ReLU
7	Output layer activation	SoftMAX

2) ADD-Net Convolutional Blocks

The convolutional block is the main block of the proposed ADD-Net and each convolutional block is consisting of a convolutional 2D, a ReLU, and an average-pooling2D. The kernel initializer is used to choose weights for the convolutional 2D layer. The ReLU activation function is used to overcome the gradient vanishing problem and allow the network to learn and perform faster. While the convolutional 2D down-samples the image and its spatial dimensions by taking the average value over an input window (of size defined by pool_size) for each channel of the input. The convolutional layers work in asymmetry and the features are gradually built. In the initial layers, local patterns like edges, lines, and curves, are extracted and local features are extracted based on these patterns as shown in Fig. 5. Consecutively, the model extracts high-level features and it enables the deep model to classify an image with more accuracy.

3) Dropout Layer

Dropout layers turn nodes on and off to reduce the training time of the model and decrease the network complexity. Dropout randomly switches off nodes using probability distribution during each epoch which prevents models from over-fitting. As a result the model learns all the relevant features and prevent diverse features in each iteration to completely.

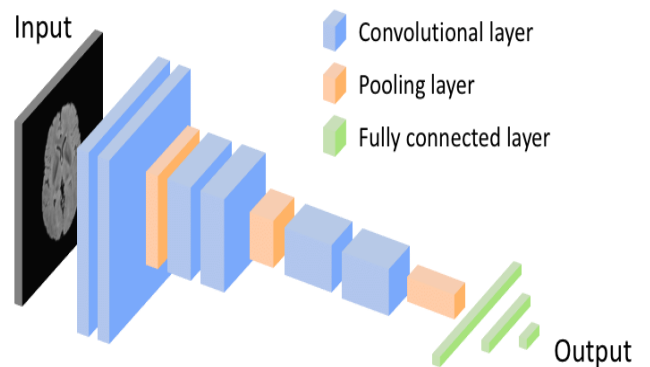

FIGURE 5: Typical CNN Model

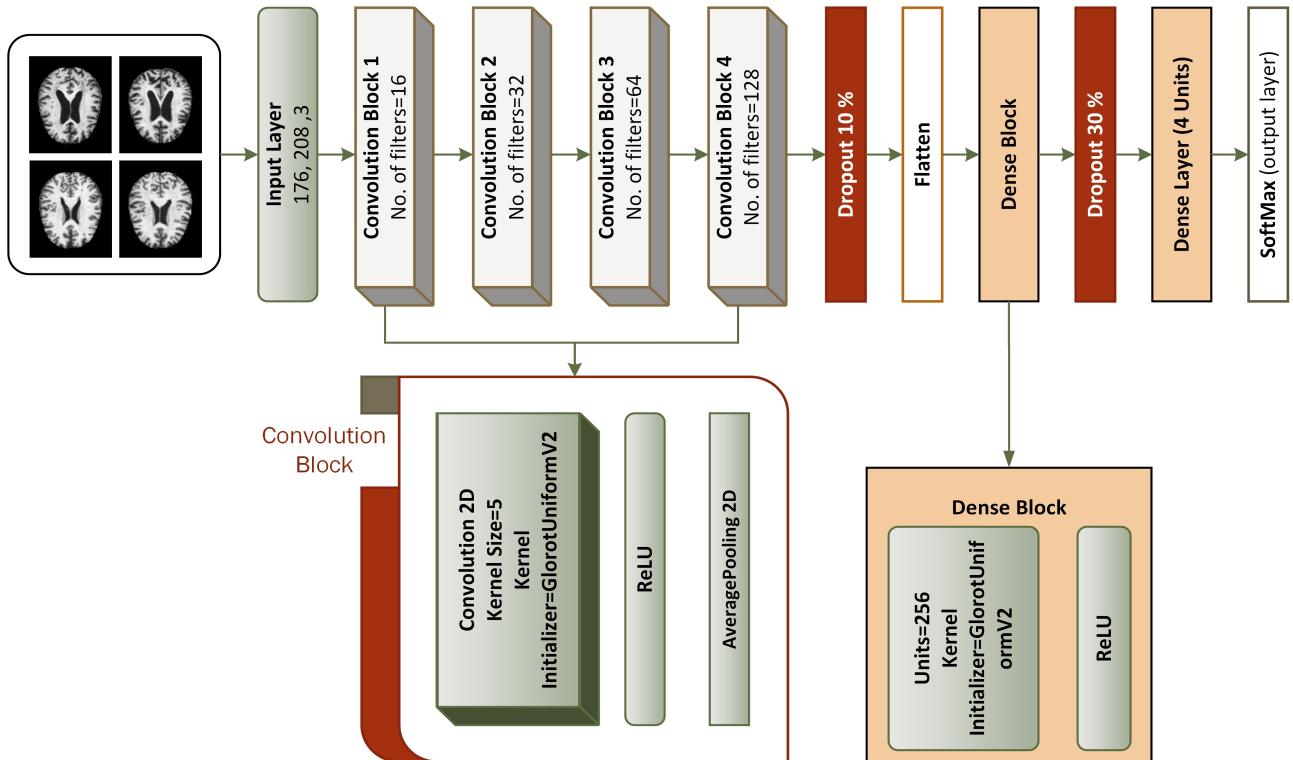

FIGURE 4: The architecture of the proposed ADD-Net for early detection of AD.

4) Flatten Layer

Flatten layer is placed between the convolution layers and dense layers. Convolution layers work with tensor data type for input while dense layers require input in a 1-Dimensional format. Flatten layer vectorize the feature map to feed it to dense layers as depicted in Fig. 6.

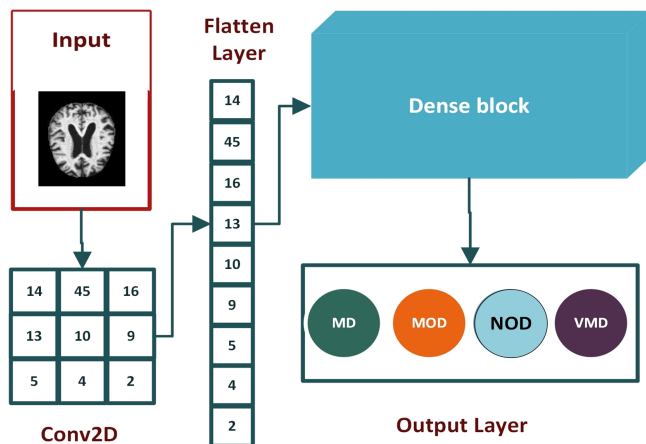

FIGURE 6: The details of flatten operation to vectorize the feature map.

C. DENSE BLOCK

There are two Dense blocks in the proposed architecture and each ADD-Net block has few layers. The details of each layer is discussed in the next subsection.

1) ReLU Activation

Activation functions are mathematical operations that decide whether output from a perceptron is to be forwarded to the next layer. In short, they activate and deactivate nodes in a deep model. The activation function is used in the output layer to activate the node which returns its label which is then assigned to the image processed through the model. There are several activation functions. We used ReLU in hidden layers because of its simple and time-saving calculation. SoftMax, a probability-based activation function, is used for the output layer because our model is for multi-class classification.

2) Dense Layer

Dense layer is also called fully connected layer. This layer input a single vector and produce output based on its parameters. The images are identified and assigned a class label in these layers. The learning of the model takes place in fully connected layers via the back-propagation method. The number of trainable parameters of a model is determined based on the number of values used in each dense layer. SoftMax is used after the couple of layers, with the number of neurons equal to the number of classes [52]. The labels are one-hot encoding in multi-class classification, and only the positive class is present in the loss term.

IV. EVALUATION OF THE PROPOSED ADD-NET MODEL

The experiments were executed on a personal computer system equipped with two Intel Xeon 2687W v4 (3.0 GHz clock speed, 12 cores and 24 threads) CPUs, 64 GB RAM, 5

GB (NVIDIA) P2000 GPU (Graphical Processing Unit). The evaluation of the model was carried out by using the test set created from the splitting of the data set earlier before training the model. Using several metrics ensures the robustness of a model from every angle. The combined understanding of these results determines the successful training of a model. For instance, in a case where accuracy is very high, say above 90% does not necessarily mean that the model is excellent. A number of other factors are involved like loss, over-fitting, etc. We employed different metrics to benchmark the performance of our model. The following four terms are extensively used when observing various metrics of a classifier:

A. ACCURACY

Accuracy is the measure of total correct predictions out of total predictions is obtained using the following expressions:

$$Accuracy = \left(\frac{TP + TN}{TP + FN + FP + TN} \right) \quad (1)$$

Where, TP, TN, FN, FP are True Positive, True Negative, False Negative, and False Positive values, respectively.

B. PRECISION

Precision is the ratio of correct positive predictions to total positive predictions and it is calculated using the following equation:

$$Precision = \left(\frac{TP}{TP + FP} \right) \quad (2)$$

C. RECALL

Recall is also known as sensitivity score or true positive rate. It is the comparison of correct positive predictions to total actual correct positives. The recall is calculated using the following equation as:

$$Recall = \left(\frac{TP}{TP + FN} \right) \quad (3)$$

D. F1-SCORE

Ideally, a value of 1.0 in precision and 1.0 in recall is considered an ideal case for a classification model. F1-score is the harmonic mean of precision and recall. F1-score is unique in a sense that it plots its graph with separate line for each class label. The F1-score is computed using the following equation as:

$$F1 = \left(2 * \frac{Precision * Recall}{Precision + Recall} \right) \quad (4)$$

E. RECEIVER OPERATING CHARACTERISTICS (ROC) CURVE

A ROC curve is a graphical way to illustrate the possible connection between sensitivity and specificity for every possible cut-off for a combination of tests. The ROC-curve graph is

illustrated with the help of 1-specificity (on the x-axis) and sensitivity (on the y-axis). While the 1-specificity is False Positive Rate and sensitivity is True Positive Rate can be obtained through the following expressions:

$$TPR = \left(\frac{FP}{FP + FN} \right) \quad (5)$$

$$FPR = \left(\frac{FP}{FP + TN} \right) \quad (6)$$

F. CONFUSION MATRIX

Confusion matrix is used to assess and calculate different metrics of a classification model. It provides the division of number all the predictions a model has made during training or testing phase.

G. LOSS FUNCTION

Loss functions calculate the mathematical difference between predicted value and actual value. For this research, we have used a categorical cross-entropy algorithm for loss.

$$Loss = y - \bar{y} \quad (7)$$

$$L_{CE} = - \sum_{n=1}^k (L_i \log(p_i)) \quad (8)$$

where \mathbf{L} is the calculated loss of each class and \mathbf{P} is the probability calculated by SOFT function.

H. THE PROPOSED MODEL COMPARISON WITH RECENT MODELS USING ROC

ROC curve is used to analyze the performance of clinical tests and more specifically the accuracy of a classifier for binary or multi-classification. The Area Under Curve (AUC) in a ROC curve is used to measure the usefulness of the classifier, where greater the AUC generally means greater the usefulness of the classifier. We check the usefulness and accuracy of our proposed ADD-Net model using the ROC curve using AD data-set with and without SMOTETOMEK. The proposed ADD-Net is compared using the ROC curve with DenseNet169, InceptionResNet V2, and VGG19 on the AD dataset. The proposed ADD-Net, DenseNet169, InceptionResNet V2, and VGG19 achieved ROC values of 79.79%, 91.17%, 82.37%, 95.21%, respectively on imbalanced AD dataset as depicted in Fig. 7. After balancing the AD dataset with SMOTETOMEK, the proposed ADD-Net, DenseNet169, InceptionResNet V2, and VGG19 achieved AUC values of 97.99%, 94.92%, 94.75%, 97.01%, respectively as depicted in Fig. 8.

I. ADD-NET COMPARISON WITH OTHER MODELS USING EXTENSION OF ROC FOR MULTI CLASS

ROC curves are commonly used in binary classification to investigate a classifier's output. Binarizing the output is

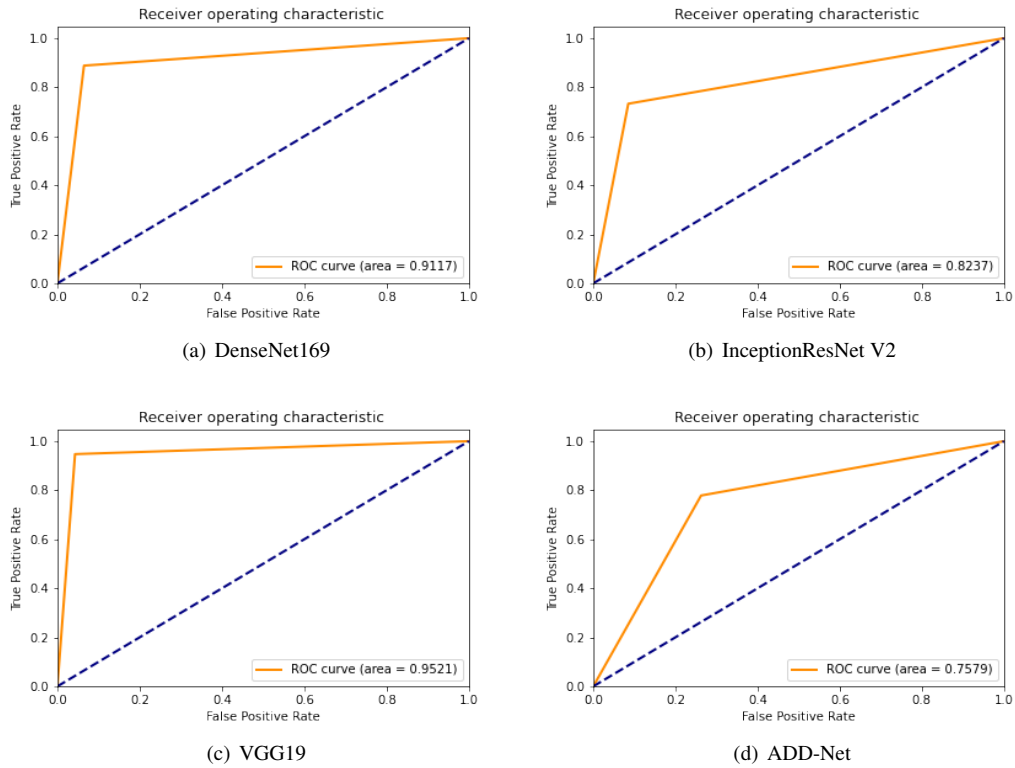

FIGURE 7: ROC Curve results of DenseNet, InceptionResNet V2, VGG19 and ADD-Net without SMOTETOMEK.

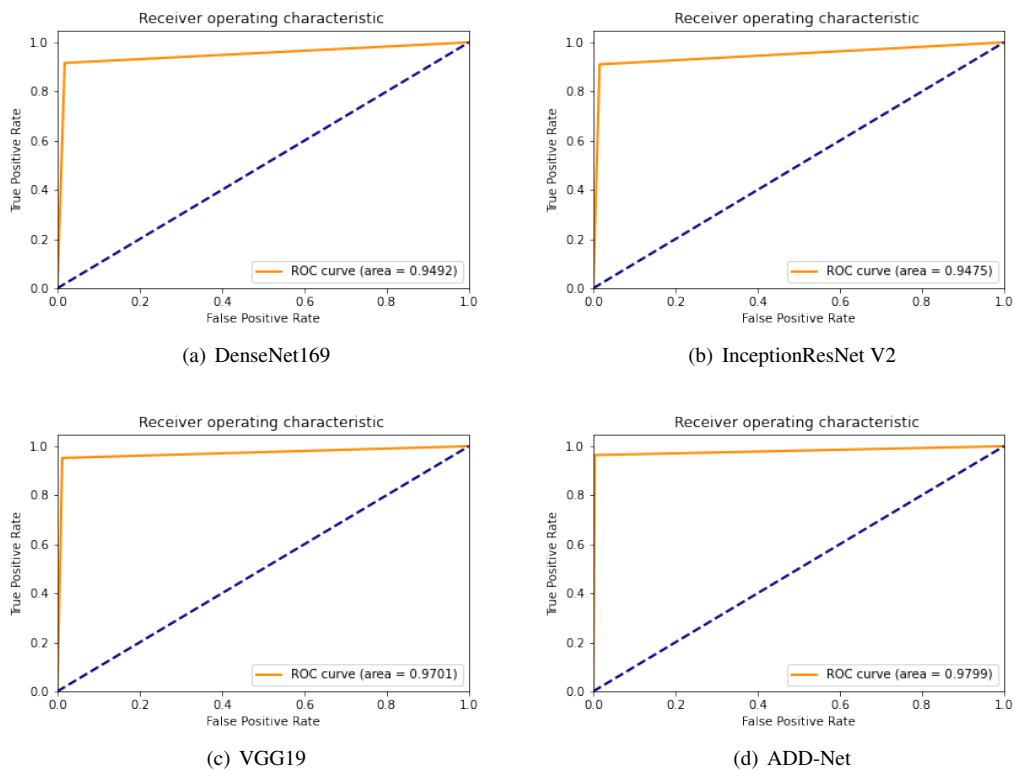

FIGURE 8: ROC curve results of DenseNet, InceptionResNet V2, VGG19 and ADD-Net with SMOTETOMEK.

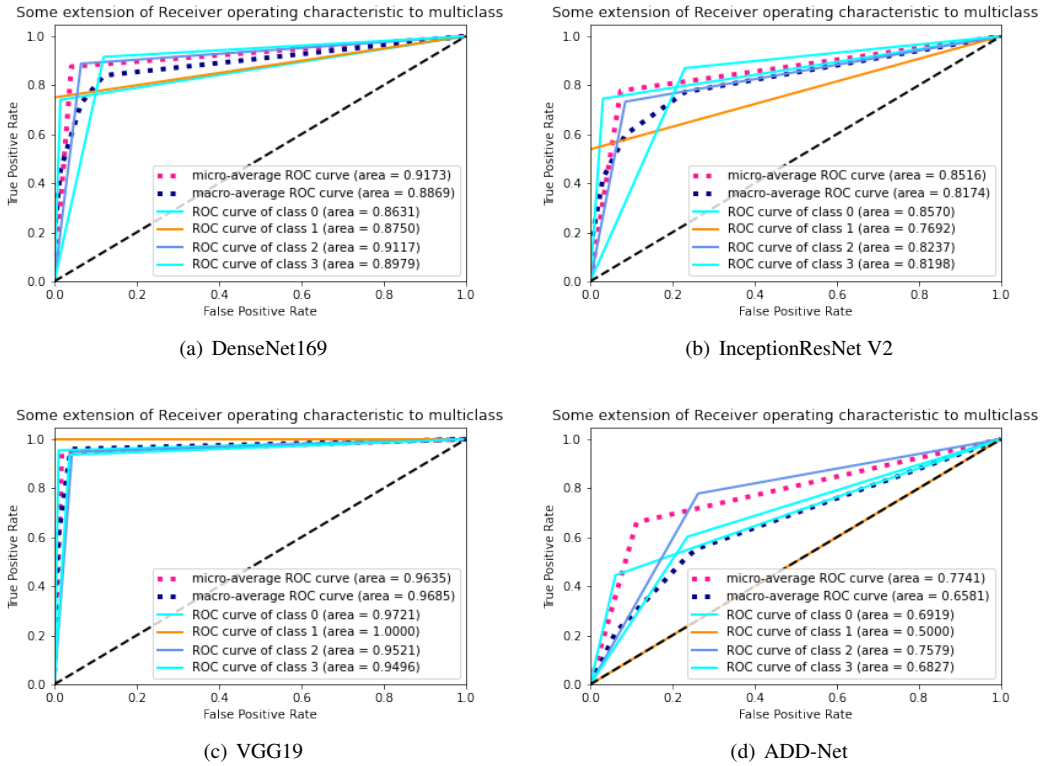

FIGURE 9: Extension Receiver results of DenseNet, InceptionResNet V2, VGG19 and ADD-Net without SMOTETOMEK.

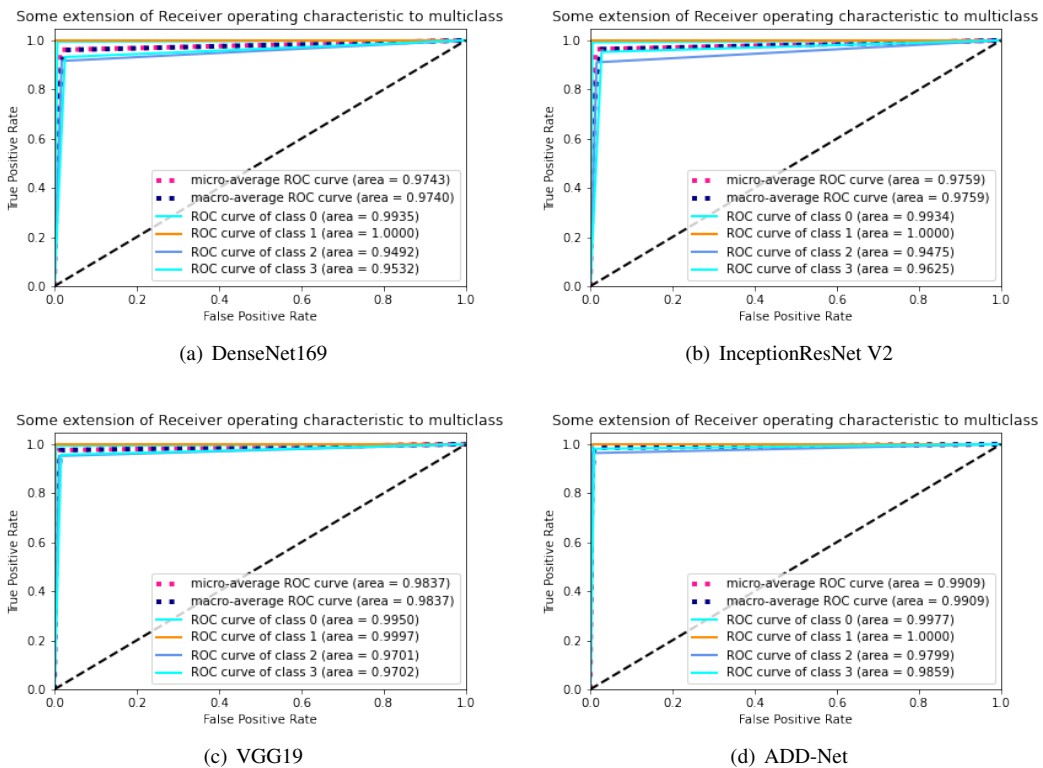

FIGURE 10: Extension Receiver results of DenseNet, InceptionResNet V2, VGG19 and ADD-Net with SMOTETOMEK.

required to expand the ROC curve and ROC area to multi-class or multi-label classification. One ROC curve can be generated for each label; however, each element of the label indicator matrix can also be treated as a binary prediction (micro-averaging). The proposed ADD-Net is compared using the Extension of the ROC curve with DenseNet169, InceptionResNet V2, and VGG19 on the balance and imbalance AD dataset as depicted in Fig. 9. We can note that after balancing the AD data-set using the SMOTETOMEK algorithm, the AUC significantly for all the approaches, as shown in Fig. 10. AUC has also noted a similar effect for all the classes of the proposed ADD-Net. The AUC of class 0 (MD), class 1 (MOD), class 2 (NOD), and class 3 (VMD) is 69.19%, 50.0%, 75.79%, and 68.27%, respectively without balancing the data-set. After balancing the AD data-set, the AUC of class 0 (MD), class 1 (MOD), class 2 (NOD), and class 3 (VMD) is 99.7%, 1.00%, 98.10%, and 98.59%, respectively. These improvements in AUC prove the authenticity of the SMOTETOMEK algorithm and feature selection of the ADD-Net model.

J. ACCURACY COMPARISON AGAINST OTHER MODEL WITH AND WITH SMOTETOMEK

SMOTETOMEK algorithm is applied on the data-set to up-sample the number of images in classes with fewer samples. It increased the size of the data-set from 6400 models to 12800 instances, i.e., 3200 equal numbers of images for each class. Hence, balancing out the data imbalance problem. The contrast between the two methods is utilizing the up-sampling technique, SMOTETOMEK.

The common point of both models is their architecture, consisting of a pre-trained model and fully connected dense layers for training. For a fair comparison, we evaluated our proposed and recent hybrid models like DenseNet169, VGG19, and InceptionResNet V2 using the same AD dataset before and after balancing it through SMOTETOMEK. The system provides remarkable results with SMOTETOMEK for the proposed model and other models. The proposed ADD-Net model, DenseNet169, VGG19, and InceptionResNet V2 achieved an accuracy of 66.1%, 87.6%, 94.5%, 77.80%, respectively, using an imbalanced AD dataset as shown in Fig. 11. All models, like ADD-Net, DenseNet169, VGG19, and InceptionResNet V2, achieved accuracies of 98.63%, 96.14%, 97.56%, 96.03%, respectively, using the balanced AD data-set. This significant improvement in accuracies of all the models is clearly visible from Fig. 12.

K. AUC COMPARISON OF PROPOSED MODELS WITH OTHER HYBRID MODELS

Several deep models were created to classify the early stages of AD. Some were conventional CNN models, while others were based on pre-trained deep architectures. Our proposed model is a deep CNN-based ADD-Net consisting of different ADD blocks and is very effective in classifying the different AD classes, as discussed earlier in this paper. We also created a few hybrid models using state-of-the-art classification mod-

els InceptionResNet V2, VGG19, and DenseNet169. The first model is a hybrid framework of DenseNet169 and MobileNet V2, reaching an AUC=98% and AUC= 99% before and after balancing the AD data-set through SMOTETOMEK as depicted in Fig. 13. The second hybrid model was created using Inception ResNet V2 and MobileNet V2, and its evaluation AUC results are 94.8% and 99.6% AUC on balanced and imbalanced AD datasets, respectively. The third hybrid model is created through MobileNet V2 and VGG19, the AUC values for this model are 95.9% and 98.89% using balanced and imbalanced AD data sets, respectively. The proposed model attained AUC values of 99.89% and 98.99% on both AD datasets, as depicted in Fig. 14. As a result of the above discussion, we noted that the performance of the proposed model remains better and more consistent in comparison with hybrid models in the form of AUC.

L. LOSS COMPARISON OF ADD-NET WITH RECENT MODELS

Loss functions calculate the mathematical difference between the predicted value and actual value. For this research, we have used a categorical cross-entropy algorithm for loss calculation. Optimisation functions are backtracking algorithms that adjust the weights and biases of layers based on the value of the loss. However, the results are even more outstanding when the model is trained with up-sampled images. The proposed model's training accuracy reached 98.60%, while the validation obtained a 96.70% accuracy, 99.82% AUC, and an F1-score of 98.61%. The Loss values for InceptionResNet V2 are 0.1041 and 0.5364, DenseNet169 is 0.1595 and 0.3187, VGG19 is 0.2083 and 0.09, and ADD-Net is 0.05 and 0.76 on both the data sets with and without up-sampling through SMOTETOMEK as depicted in Figs. 15 and 16. Comparison of ADD-Net with Recent Models Using F1-Score The input data set is normalised in this suggested ADD-Net model. The fundamental procedure of converting categorical data variables is delivered to the model utilising the one-hot encoder. The SMOTETOMEK technique is then used to correct the unbalanced data-set problem by oversampling the classes to balance the data set. We evaluated the ADD-Net model on the AD data-set with recent models like Dense Net169, VGG19, and InceptionResNet V2 for a fair comparison. The system using SMOTETOMEK produces remarkable results for the suggested model and other models. The proposed ADD-Net model, DenseNet169, VGG19, and InceptionResNet V2 achieved F1-score of 46.04%, 85.5%, 95.81%, 75.68%, respectively using an imbalanced AD data-set as shown in Fig. 17. All models, like ADD-Net, DenseNet169, VGG19, and InceptionResNet V2, achieved an F1-score of 98.6%, 96%, 97.50%, 96.1%, respectively, using the balanced AD data-set. This significant improvement in accuracies of all the models is clearly visible from Fig. 18.

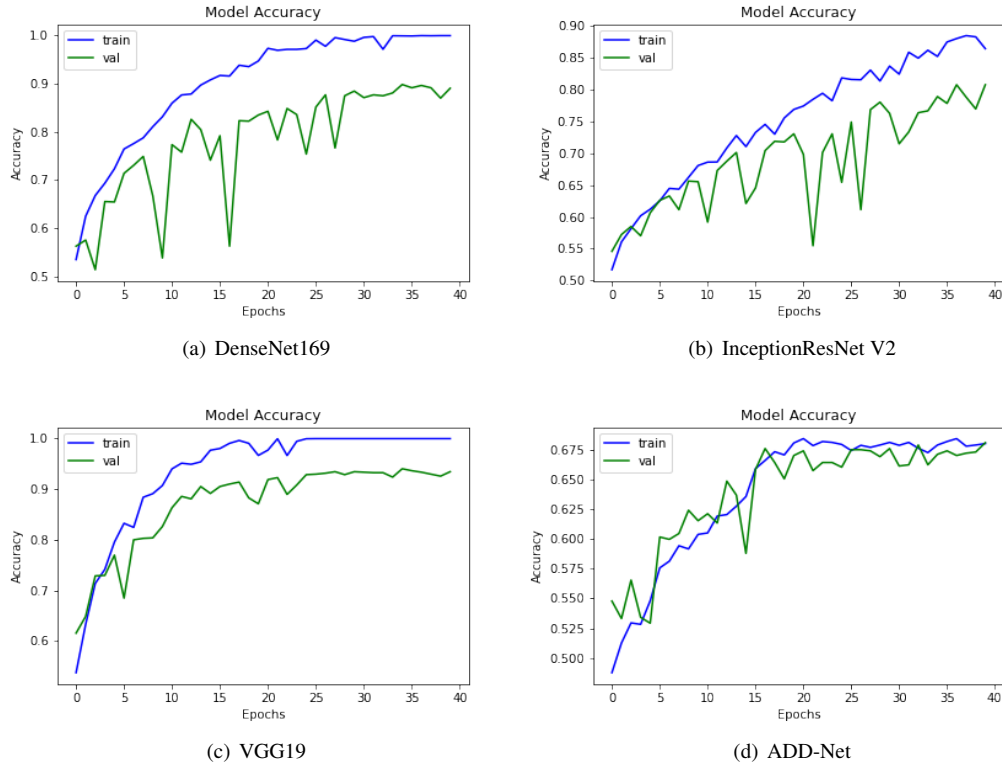

FIGURE 11: Accuracy Comparison of DenseNet169, InceptionResNet V2, VGG19 and ADD-Net without SMOTETOMEK.

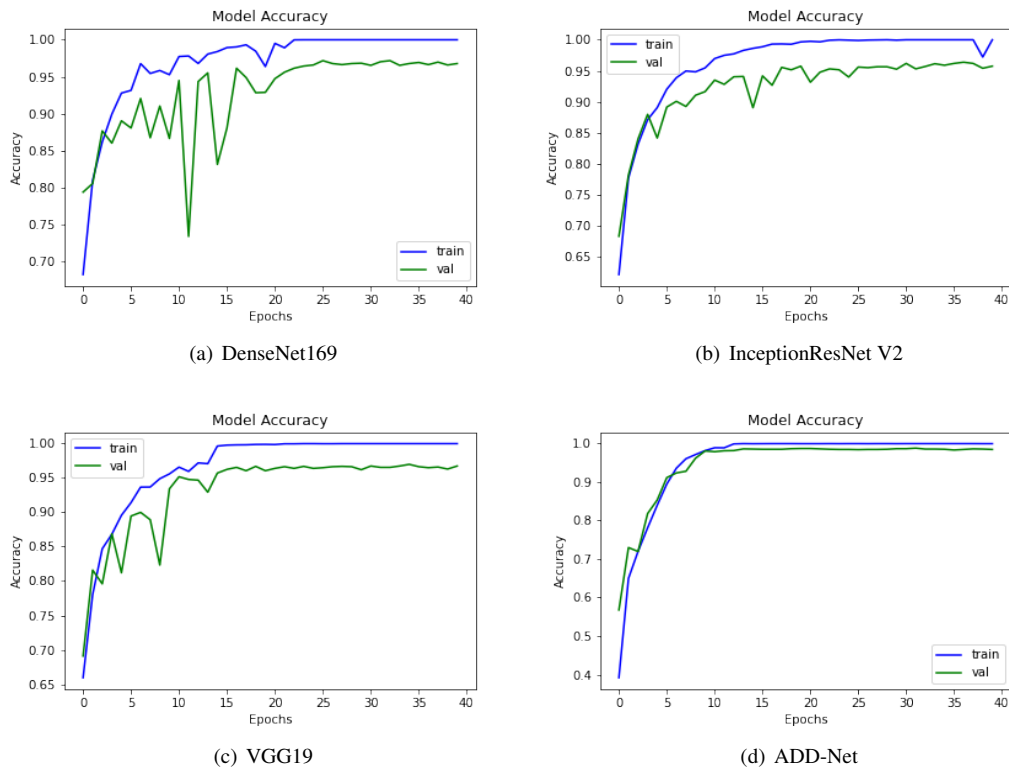

FIGURE 12: Training process Accuracy of DenseNet, InceptionResNet V2, VGG19 and ADD-Net with SMOTETOMEK.

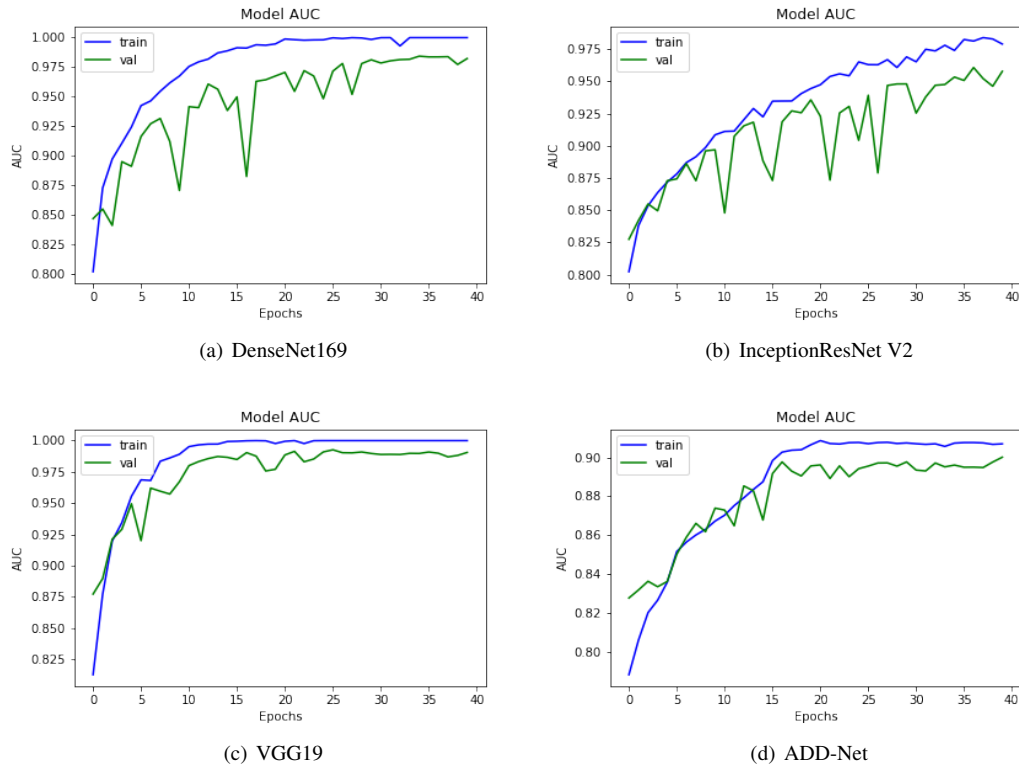

FIGURE 13: Training process AUC of DenseNet, InceptionResNet V2, VGG19 and ADD-Net without SMOTETOMEK.

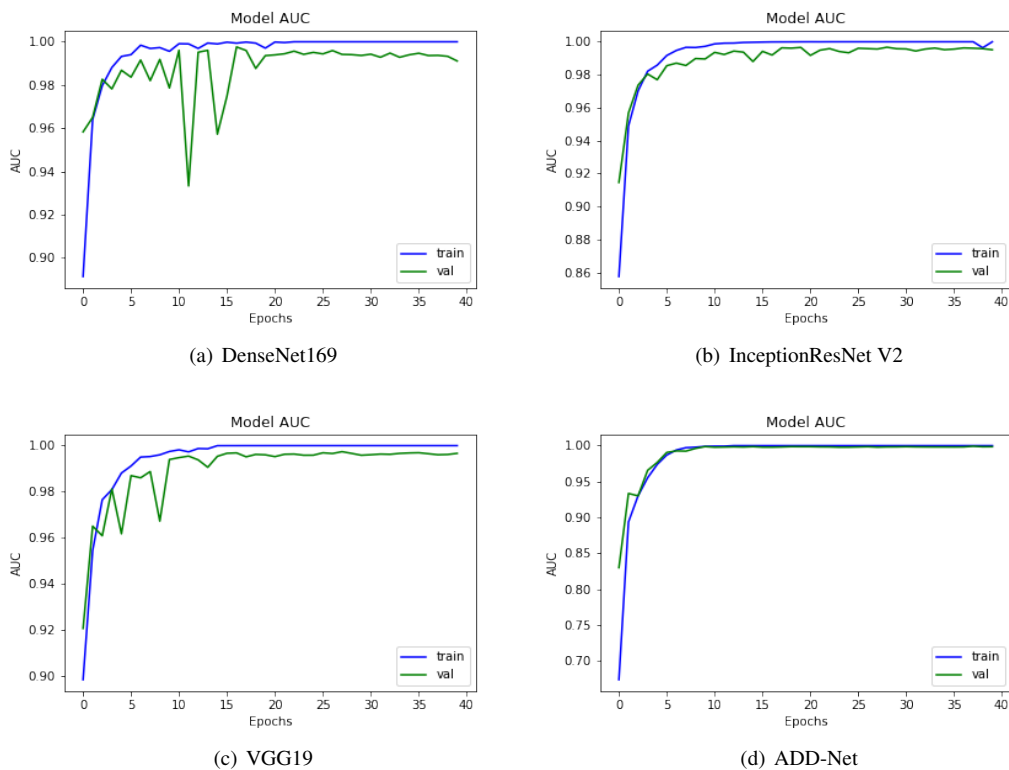

FIGURE 14: Training process AUC of DenseNet, InceptionResNet V2, VGG19 and ADD-Net with SMOTETOMEK.

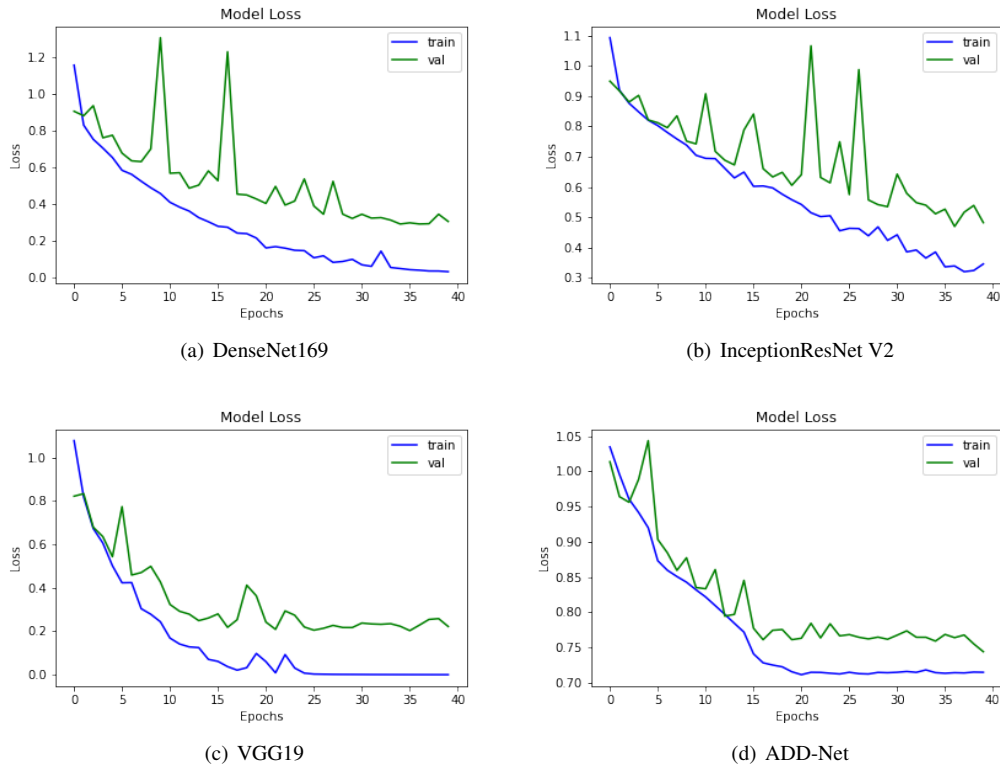

FIGURE 15: Training Loss of DenseNet, InceptionResNet V2, VGG19 and ADD-Net without SMOTETOMEK.

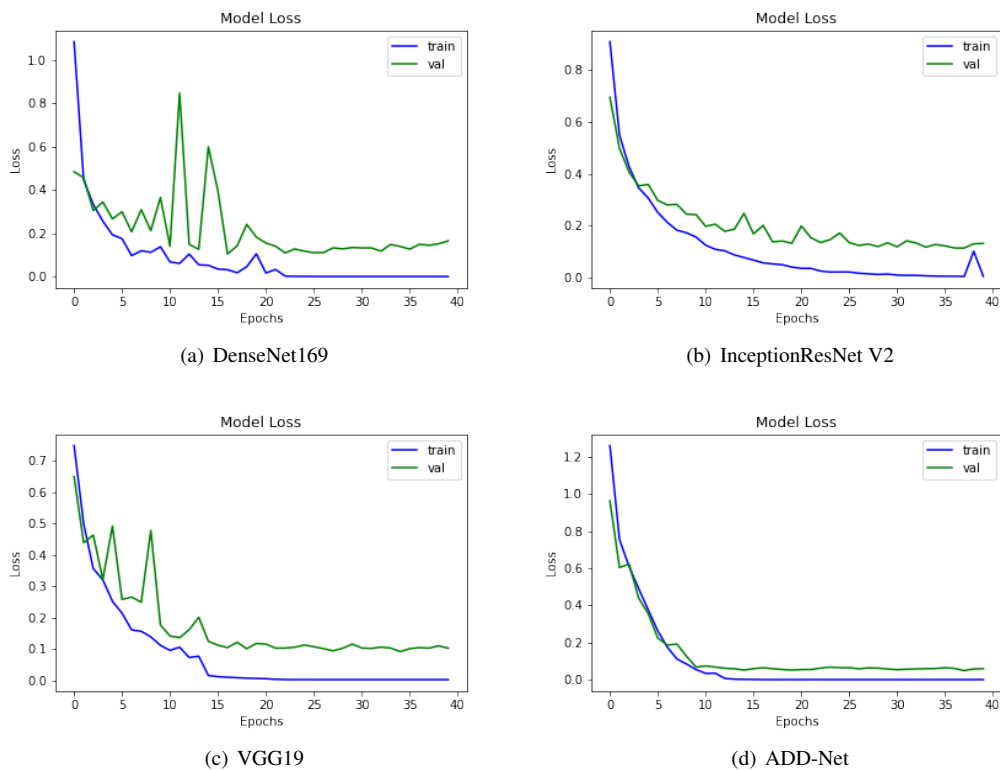

FIGURE 16: Training Loss of DenseNet, InceptionResNet V2, VGG19 and ADD-Net with SMOTETOMEK.

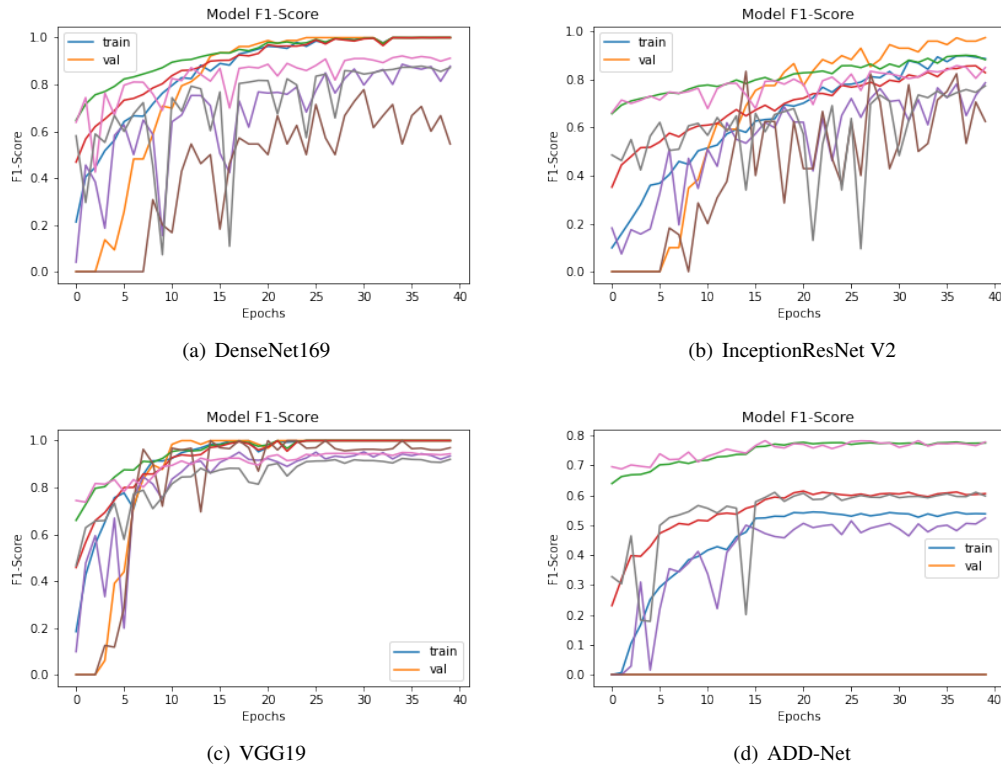

FIGURE 17: F1-Score of DenseNet, InceptionResNet V2, VGG19 and ADD-Net without SMOTETOMEK.

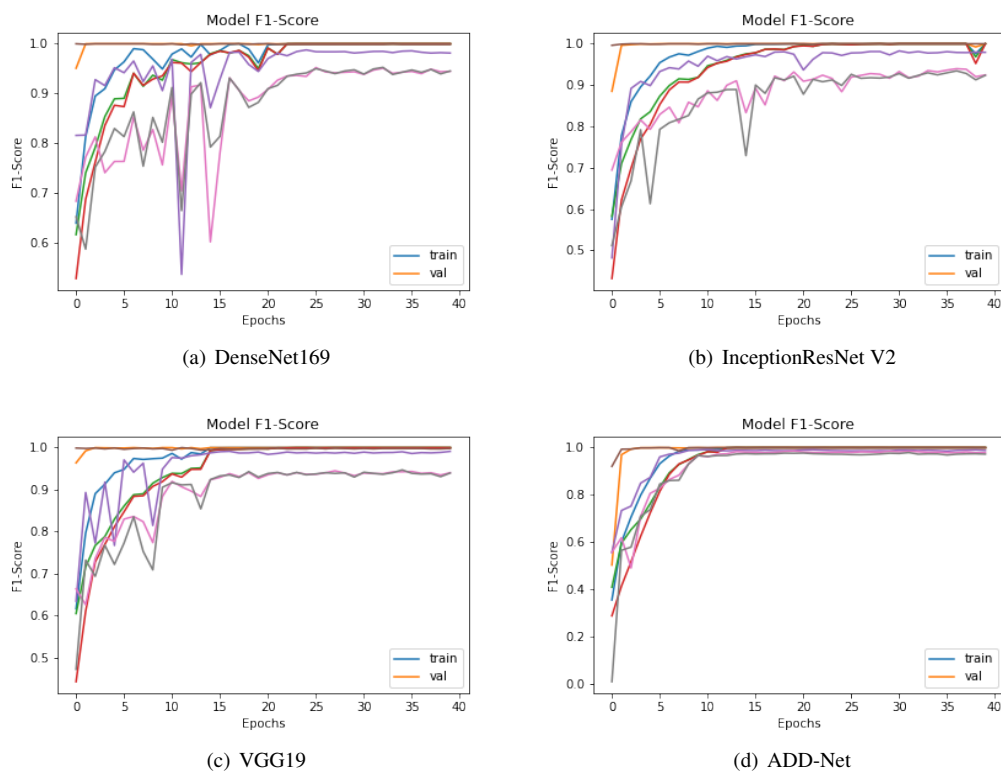

FIGURE 18: F1-Score of DenseNet, InceptionResNet V2, VGG19 and ADD-Net with SMOTETOMEK.

M. COMPARISON OF ADD-NET WITH RECENT MODELS USING PRECISION

Several deep models were developed to classify Alzheimer's disease in its early stages. Some algorithms were traditional CNN, while others were pre-trained deep architectures. As mentioned earlier in this paper, our proposed model is a deep CNN-based ADD-Net comprising distinct ADD blocks. We compared our model with the InceptionResNet V2, VGG19, and DenseNet169 classification models as shown in Fig. 19; the first model is a hybrid framework of DenseNet169 and MobileNet V2 with precision values 88.7% 96.1% and before and after balancing the AD data-set using SMOTETOMEK. The second hybrid model was built with Inception ResNet-V2 and MobileNet V2, and its evaluation precision values are 79.9% 96.6% on balanced and unbalanced tasks, respectively. The third hybrid model is developed using MobileNet V2 and VGG19, with precision values are 94.7% and 97.6%, respectively, utilising balanced and imbalanced AD data sets. As shown in Fig. 20, the proposed model achieved precision values are 74.5% 98.60% on both AD datasets. As a result of the preceding discussion, we discovered that the presented model's performance is better and more consistent than hybrid models in the form of precision.

N. COMPARISON OF ADD-NET WITH RECENT MODELS USING CONFUSION MATRIX

In this proposed ADD-Net model, the input data-set is pre-processed using normalization and the essential process of converting the categorical data variables to be provided to the model using the one-hot encoder.

Then, the SMOTETOMEK algorithm is applied to resolve the imbalanced data-set issue that over-samples the classes to balance the data-set. For a fair comparison, we assessed ADD-Net model with recent models selected for comparison like DenseNet169, VGG19, and InceptionResNet V2 on AD dataset before and after balancing it through SMOTETOMEK up-sampling algorithm. Remarkable results are provided by the system with SMOTETOMEK for the proposed model and other models as depicted in Figs. 21 and 22.

O. VISUALIZATION THROUGH GRADIENT-WEIGHTED CLASS ACTIVATION MAP

Grad-CAM detects the discriminatory regions for a CNN classification by calculating its CAM using gradient data. Grad-CAM visualizes a map of all the working classes by integrating gradient information. Grad-CAM considers 2D activation's along with the average gradient information. It supports recognizing what a network perceives, and which particular neuron is firing in a specific deep layer [51]. The preceding class gradient is related to the channel, ensuing the last CNN layer to generate a localization CAM displaying the important locations in the image that has a substantial effect on the deep model's prediction as shown in Fig. 23. To generate the CAM, the class gradient score is computed relative to the feature maps of the CNN layers [51].

P. DISCUSSION AND COMPARISON WITH OTHERS DEEP MODELS USING UP-SAMPLING

The previous models used for comparison in this paper are not very effective in handling data imbalance problems and are limited in their performance. Sometimes suffer from over-fitting because of this data imbalance issue or lost their accuracy in properly detecting the AD classes. The ADD-NET achieved maximum accuracy is achieved by using the SMOTETOMEK, however, the DEMENET achieved an accuracy of 92.88% using the SMOTE algorithm. Among all the deep CNN models, deep transfer learning models, and hybrid models that we used for comparison in this research study the proposed model performed with distinction. All the simulation results using different quality metrics are evident of the performance of deep ADD-NET. The detailed comparison of ADD-Net and other deep models with SMOTE-TOMEK is discussed in Table 6.

V. LIMITATIONS

In this proposed study we present a deep learning-based classification model named "ADD-Net" for the classification of early stage of Alzheimer's disease. Although, ADD-Net outperforms with respect to other models but still has some shortcomings, however, the proposed mode efficiency suffers on imbalanced dataset. As we discuss above due to an imbalanced dataset the accuracy of deep learning models is compromised, our model is suffering from the same problem when the dataset has a different number of samples in each class.

VI. CONCLUSION

In this paper, we proposed a novel deep CNN for detecting AD with relatively few parameters and the proposed solution is ideal for training a smaller dataset. The proposed Alzheimer's Disease Detection Network (ADD-Net) is built from scratch to precisely classify the stages of AD by decreasing parameters and calculation costs. Each block is precisely designed with many layers named ADD-block which is engaged to classify the AD in its early stages for all the specific classes. SMOTETOMEK method is employed for handling data-set imbalance problems for generating new instances to balance the number of samples for each class. Grad-CAM algorithm provides insight into CNN layers' working by visualizing class activation heat-map. Our proposed deep model provides outstanding accuracy of 96.70%, 97% precision, Sensitivity (Recall) of 97%, and an impressive AUC value of 99.82%. We will involve other pre-trained architectures and fine-tune transfer learning models to achieve more desirable results in the future.

REFERENCES

- [1] A. Thaver, A. Ahmad, Economic perspective of dementia care in pakistan, *Neurology* 90 (2018) e993–e994.
- [2] P. Serge, V. Miquel, J. Vernice, Neurodegeneration: what is it and where are we, *J Clin Invest* 111 (2003) 3 'A10.
- [3] A. M. Sanford, Mild cognitive impairment, *Clinics in geriatric medicine* 33 (2017) 325–337.

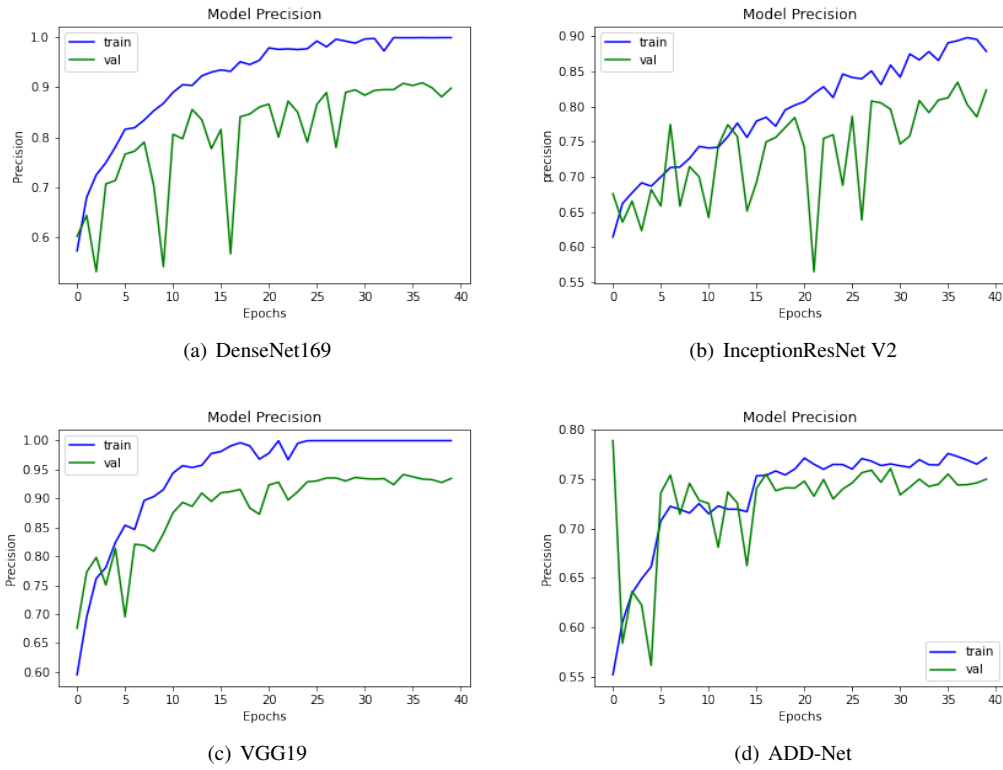

FIGURE 19: Precision results of DenseNet, InceptionResNet V2, VGG19 and ADD-Net without SMOTETOMEK.

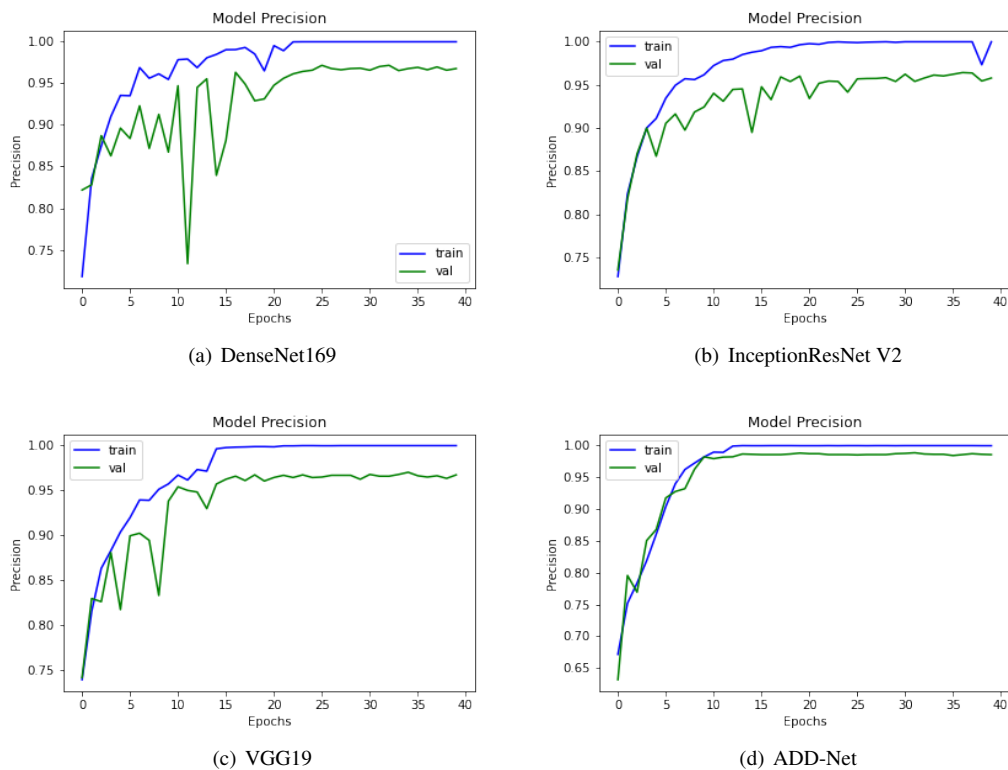

FIGURE 20: Precision results of DenseNet, InceptionResNet V2, VGG19 and ADD-Net with SMOTETOMEK.

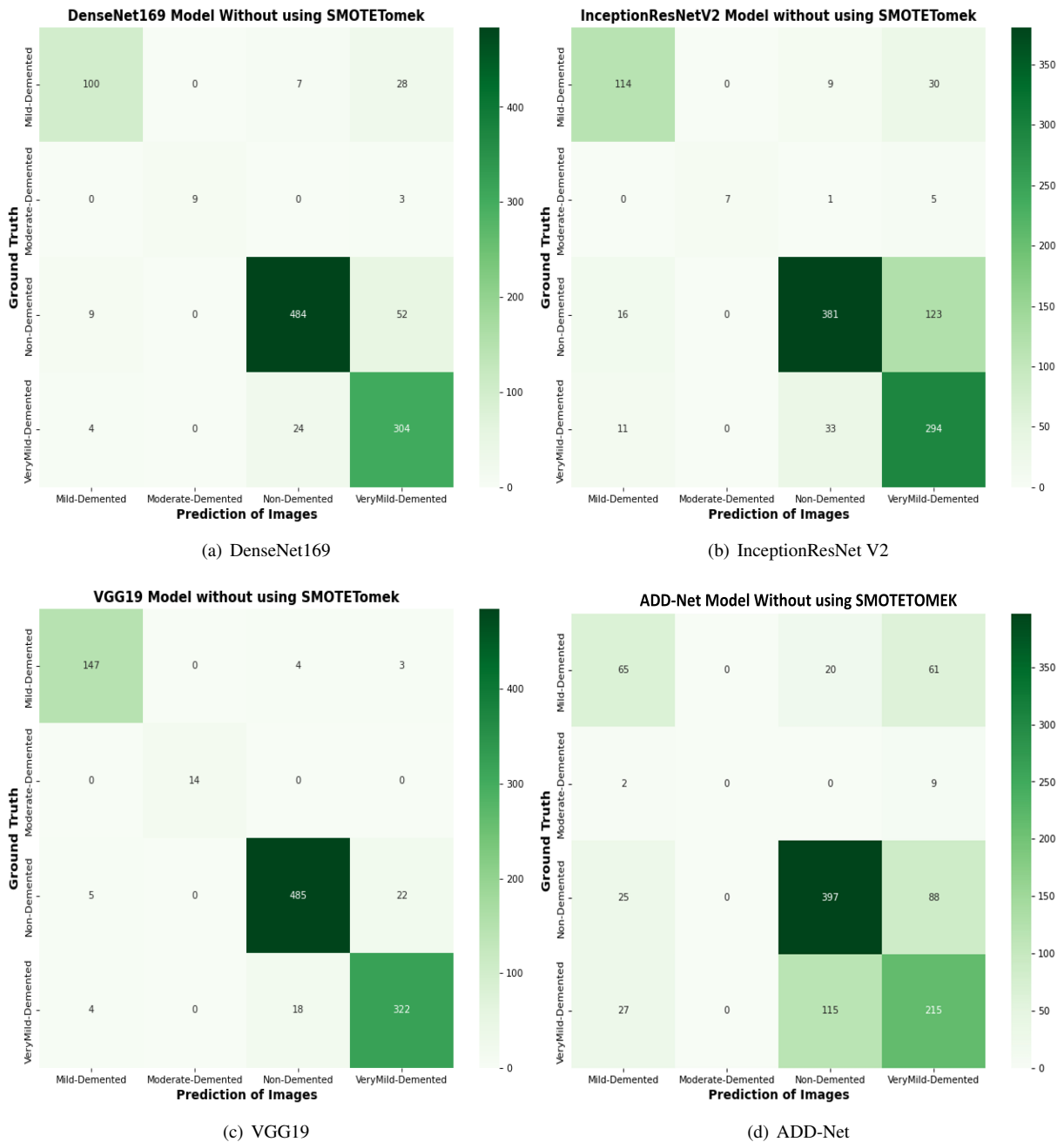

FIGURE 21: Confusion matrix's of state-of-the-art algorithms and ADD-Net model without using SMOTETOMEK.

[4] A. B. Tufail, Y.-K. Ma, Q.-N. Zhang, Binary classification of alzheimer's disease using smri imaging modality and deep learning, *Journal of digital imaging* 33 (2020) 1073–1090.

[5] K. Doi, Computer-aided diagnosis in medical imaging: historical review, current status and future potential, *Computerized medical imaging and graphics* 31 (2007) 198–21.

[6] S. Tiwari, V. Atluri, A. Kaushik, A. Yndart, M. Nair, Alzheimer's disease: pathogenesis, diagnostics, and therapeutics, *International journal of nanomedicine* 14 (2019) 5541.

[7] C. Duyckaerts, B. Delatour, M.-C. Potier, Classification and basic pathology of alzheimer disease, *Acta neuropathologica* 118 (2009) 5–36.

[8] L. G. Apostolova, A. E. Green, S. Babakchianian, K. S. Hwang, Y.-Y. Chou, A. W. Toga, P. M. Thompson, Hippocampal atrophy and ventricular enlargement in normal aging, mild cognitive impairment and alzheimer's disease, *Alzheimer disease and associated disorders* 26 (2012) 17.

[9] J. C. de la Torre, Alzheimer's disease is incurable but preventable, *Journal of Alzheimer's disease* 20 (2010) 861–870.

[10] D. A. Casey, D. Antimisiaris, J. O'Brien, Drugs for alzheimer's disease: are they effective?, *Pharmacy and Therapeutics* 35 (2010) 208.

[11] M. Prince, M. Knapp, M. Guerchet, P. McCrone, M. Prina, A. Comas-Herrera, R. Wittenberg, B. Adelaja, B. Hu, D. King, et al., *Dementia uk: -overview* (2014).

[12] E. Nichols, J. D. Steinmetz, S. E. Vollset, K. Fukutaki, J. Chalek, F. Abd-Allah, A. Abdoli, A. Abualhasan, E. Abu-Gharbieh, T. T. Akram, et al., Estimation of the global prevalence of dementia in 2019 and forecasted prevalence in 2050: an analysis for the global burden of disease study 2019, *The Lancet Public Health* 7 (2022) e105–e125.

[13] M. Tanveer, B. Richhariya, R. Khan, A. Rashid, P. Khanna, M. Prasad,

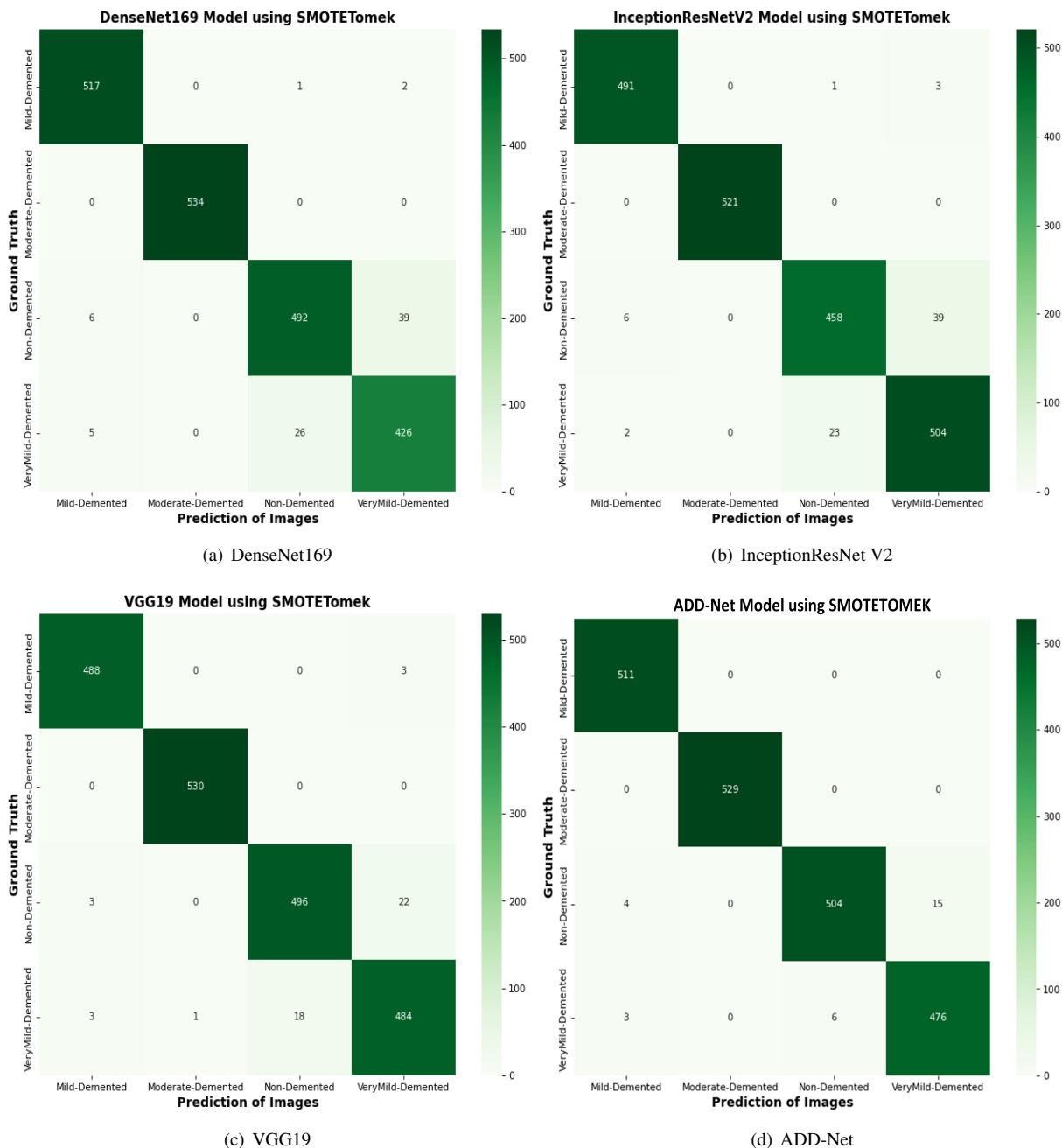

FIGURE 22: Confusion matrix's of state-of-the-art algorithms and ADD-Net model with using SMOTETOMEK.

C. Lin, Machine learning techniques for the diagnosis of alzheimer's disease: A review, *ACM Transactions on Multimedia Computing, Communications, and Applications (TOMM)* 16 (2020) 1–35.

[14] M. A. EbrahimiGhahnavieh, S. Luo, R. Chiong, Deep learning to detect alzheimer's disease from neuroimaging: A systematic literature review, *Computer methods and programs in biomedicine* 187 (2020) 105242.

[15] J. Zhuang, J. Cai, R. Wang, J. Zhang, W.-S. Zheng, Deep knn for medical image classification, in: *International Conference on Medical Image Computing and Computer-Assisted Intervention*, Springer, 2020, pp. 127–136.

[16] R. Suganthe, M. Geetha, G. Sreekanth, K. Gowtham, S. Deepakkumar, R. Elango, Multiclass classification of alzheimer's disease using hybrid deep convolutional neural network, *NVEO-NATURAL VOLATILES ESSENTIAL OILS Journal—NVEO* (2021) 145–153.

[17] X. Jiang, L. Chang, Y.-D. Zhang, Classification of alzheimer's disease via eight-layer convolutional neural network with batch normalization and dropout techniques, *Journal of Medical Imaging and Health Informatics* 10 (2020) 1040–1048.

[18] P. Kalavathi, V. Prasath, Methods on skull stripping of mri head scan images—a review, *Journal of digital imaging* 29 (2016) 365–379.

[19] S. Basheera, M. S. S. Ram, A novel cnn based alzheimer's disease classification using hybrid enhanced ica segmented gray matter of mri, *Computerized Medical Imaging and Graphics* 81 (2020) 101713.

[20] M. K. Singh, K. K. Singh, A review of publicly available automatic brain segmentation methodologies, machine learning models, recent advancements, and their comparison, *Annals of Neurosciences* 28 (2021) 82–93.

[21] J. V. Manj on, P. Coup e, volbrain: an online mri brain volumetry system, *Frontiers in neuroinformatics* 10 (2016) 30.

TABLE 6: Performance comparison of ADD-Net with state-of-the-art algorithms.

Reference	Dataset	Accuracy	AUC	Precision	Recall	F1-score
Proposed ADD-Net (with SMOTETOMEK)	Kaggle	97.05%	99.89%	97%	97%	97.05%
Proposed ADD-Net (without SMOTETOMEK)	Kaggle	92.88%	98.99%	82%	89%	84.55%
DEMNET (with SMOTE)	Kaggle	95.23%	97%	96%	95%	95%
DEMNET (without SMOTE)	Kaggle	85%	92%	80%	88%	83%
Conv-BLSTM (SMOTE)	ADNI	82%	91%	78%	88%	82%
Conv-BLSTM (GAIN)	ADNI	82%	90%	79%	82%	82%
VGG16	ADNI	95.73%	-	96.33%	96%	95%
AlexNet	Kaggle	92.20%	99.45%	-	94.50%	-
ResNet-50	Kaggle	93.10%	98.82%	-	92.25%	-
Inception ResNet v2	Kaggle	79.12%	81.90%	70.64%	28.22%	39.91%

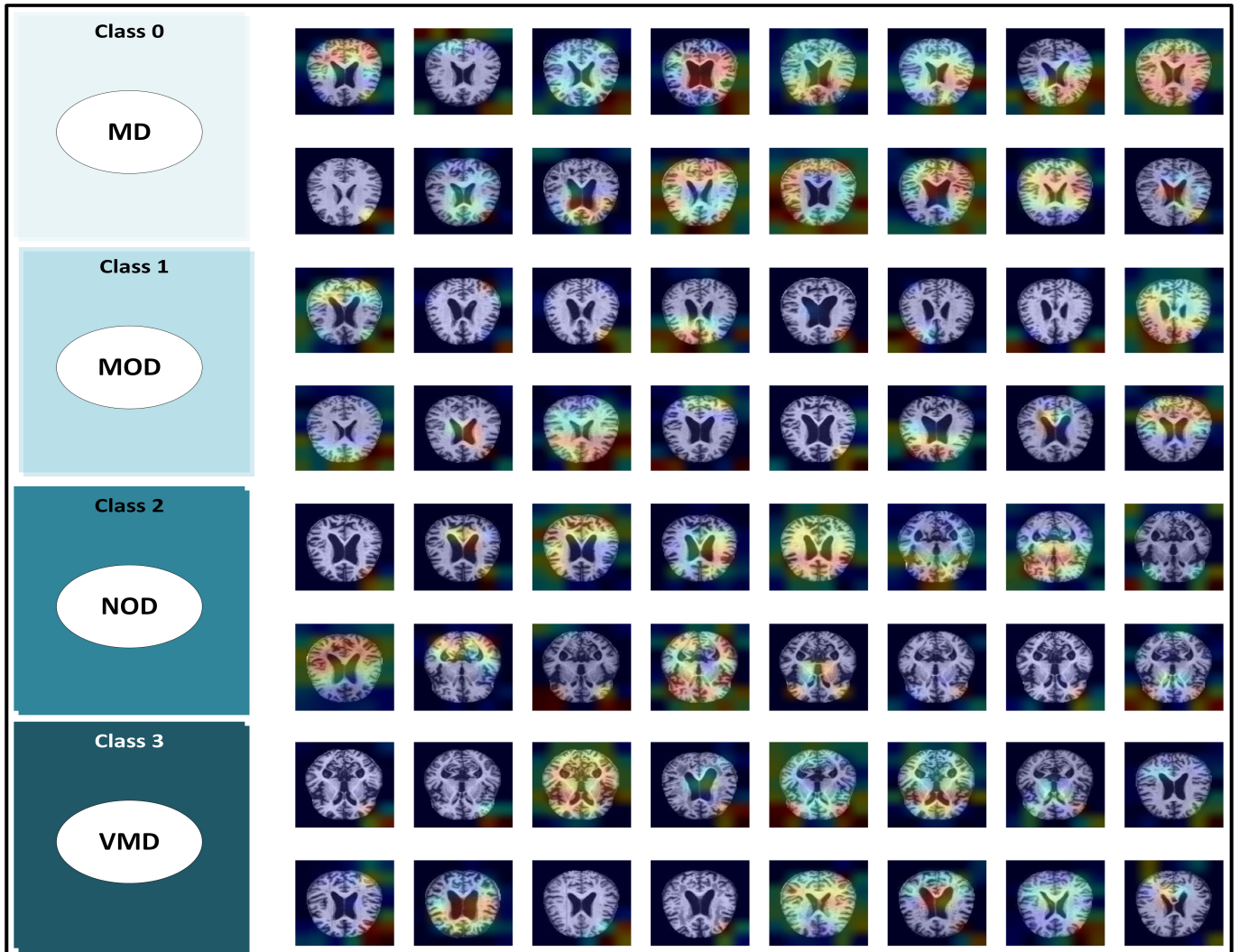

FIGURE 23: Generalization of the class activation map to locate the discriminative region through Grad-CAM.

- [22] B.-y. Park, K. Byeon, H. Park, Funp (fusion of neuroimaging preprocessing) pipelines: a fully automated preprocessing software for functional magnetic resonance imaging, *Frontiers in neuroinformatics* 13 (2019) 5.
- [23] M. D. Zeiler, R. Fergus, Visualizing and understanding convolutional networks, in: *European conference on computer vision*, Springer, 2014, pp. 818–833.
- [24] R. R. Selvaraju, M. Cogswell, A. Das, R. Vedantam, D. Parikh, D. Batra, Grad-cam: Visual explanations from deep networks via gradient-based localization, in: *Proceedings of the IEEE international conference on computer vision*, 2017, pp. 618–626.
- [25] L. Alzubaidi, M. A. Fadhel, O. Al-Shamma, J. Zhang, J. Santamaría, Y. Duan, S. R. Olewi, Towards a better understanding of transfer learning for medical imaging: a case study, *Applied Sciences* 10 (2020) 4523.
- [26] M. W. Weiner, D. P. Veitch, P. S. Aisen, L. A. Beckett, N. J. Cairns, R. C. Green, D. Harvey, C. R. Jack, W. Jagust, E. Liu, et al., The alzheimer's disease neuroimaging initiative: a review of papers published since its inception, *Alzheimer's Dementia* 9 (2013) e111–e194.
- [27] D. Marcus, T. Wang, et al., Oasis: cross-sectional, mri data in young, middle aged, nondemented, and demented, older adults, *Journal of cognitive neuroscience*.
- [28] J. Li, S. Fong, S. Mohammed, J. Fiaidhi, Improving the classification performance of biological imbalanced datasets by swarm optimization algorithms, *The Journal of Supercomputing* 72 (2016) 3708–3728.
- [29] N. I. G. Shereen A El-Aal, A proposed recognition system for alzheimer's disease based on deep learning and optimization algorithms, *Journal of Southwest Jiaotong University* 56 (2021).
- [30] B. A. Mohammed, E. M. Senan, T. H. Rassem, N. M. Makbol, A. A. Alanazi, Z. G. Al-Mekhlafi, T. S. Almurayziq, F. A. Ghaleb, Multimethod analysis of medical records and mri images for early diagnosis of dementia and alzheimer's disease based on deep learning and hybrid methods, *Electronics* 10 (2021) 2860.
- [31] B. A. Mohammed, E. M. Senan, T. H. Rassem, N. M. Makbol, A. A. Alanazi, Z. G. Al-Mekhlafi, T. S. Almurayziq, F. A. Ghaleb, Multimethod analysis of medical records and mri images for early diagnosis of dementia and alzheimer's disease based on deep learning and hybrid methods, *Electronics* 10 (2021) 2860.
- [32] A. Pradhan, J. Gige, M. Eliazar, Detection of alzheimer's disease (ad) in mri images using deep learning, *Int. J. Eng. Res. Technol. (IJERT)* 10 (2021) 580–585.
- [33] G. Vasukidevi, S. Ushasukhanya, P. Mahalakshmi, Efficient image classification for alzheimer's disease prediction using capsule network, *Annals of the Romanian Society for Cell Biology* (2021) 806–815.
- [34] G. Battineni, N. Chintalapudi, F. Amenta, E. Traini, Deep learning type convolution neural network architecture for multiclass classification of alzheimer's disease., in: *BIOIMAGING*, 2021, pp. 209–215.
- [35] J. Islam, Y. Zhang, Brain MRI analysis for alzheimer's disease diagnosis using an ensemble system of deep convolutional neural networks, *Brain informatics* 5 (2018) 1–14.
- [36] J. Islam, Y. Zhang, An ensemble of deep convolutional neural networks for alzheimer's disease detection and classification, *arXiv preprint arXiv:1712.01675* (2017).
- [37] J. Islam, Y. Zhang, Early diagnosis of alzheimer's disease: A neuroimaging study with deep learning architectures, in: *Proceedings of the IEEE conference on computer vision and pattern recognition workshops*, 2018, pp. 1881–1883.
- [38] C. Szegedy, S. Ioffe, V. Vanhoucke, A. A. Alemi, Inception-v4, inception-resnet and the impact of residual connections on learning, in: *Thirty-first AAAI conference on artificial intelligence*, 2017.
- [39] C. Szegedy, S. Ioffe, V. Vanhoucke, A. A. Alemi, Inception-v4, inception-resnet and the impact of residual connections on learning, in: *Thirty-first AAAI conference on artificial intelligence*, 2017.
- [40] S. H. Khan, M. Hayat, M. Bennamoun, F. A. Sohel, R. Togneri, Cost-sensitive learning of deep feature representations from imbalanced data, *IEEE transactions on neural networks and learning systems* 29 (2017) 3573–3587.
- [41] S. H. Khan, M. Hayat, M. Bennamoun, F. A. Sohel, R. Togneri, Cost-sensitive learning of deep feature representations from imbalanced data, *IEEE transactions on neural networks and learning systems* 29 (2017) 3573–3587.
- [42] B. Xu, N. Wang, T. Chen, M. Li, Empirical evaluation of rectified activations in convolutional network, *arXiv preprint arXiv:1505.00853* (2015).
- [43] A. F. Agarap, Deep learning using rectified linear units (relu), *arXiv preprint arXiv:1803.08375* (2018).
- [44] M. M. Lau, K. H. Lim, Review of adaptive activation function in deep neural network, in: *2018 IEEE-EMBS Conference on Biomedical Engineering and Sciences (IECBES)*, IEEE, 2018, pp. 686–69.
- [45] F. Chollet, Xception: Deep learning with depthwise separable convolutions, in: *Proceedings of the IEEE conference on computer vision and pattern recognition*, 2017, pp. 1251–1258.
- [46] A. G. Howard, M. Zhu, B. Chen, D. Kalenichenko, W. Wang, T. Weyand, M. Andreetto, H. Adam, Mobilenets: Efficient convolutional neural networks for mobile vision applications, *arXiv preprint arXiv:1704.04861* (2017).
- [47] G. Huang, Z. Liu, L. Van Der Maaten, K. Q. Weinberger, Densely connected convolutional networks, in: *Proceedings of the IEEE conference on computer vision and pattern recognition*, 2017, pp. 4700–4708.
- [48] T. Fushiki, Estimation of prediction error by using k-fold cross-validation, *Statistics and Computing* 21 (2011) 137–146.
- [49] J. Huang, C. X. Ling, Using auc and accuracy in evaluating learning algorithms, *IEEE Transactions on Knowledge and Data Engineering* 17 (2005) 299–310.
- [50] N. C. Thompson, K. Greenwald, K. Lee, G. F. Manso, The computational limits of deep learning, *arXiv preprint arXiv:2007.05558* (2020).
- [51] F. Wen, A. K. David, A genetic algorithm based method for bidding strategy coordination in energy and spinning reserve markets, *Artificial Intelligence in Engineering* 15 (2001) 71–79.
- [52] L. Wang, X. Wang, J. Fu, L. Zhen, A novel probability binary particle swarm optimization algorithm and its application., *J. Softw.* 3 (2008) 28–35.
- [53] M. Raju, M. Thirupalani, S. Vidhyabharathi, S. Thilagavathi, Deep learning based multilevel classification of alzheimer's disease using mri scans, in: *IOP Conference Series: Materials Science and Engineering*, volume 1084, IOP Publishing, 2021, p. 012017.
- [54] J. Howard, S. Gugger, Fastai: a layered api for deep learning, *Information* 11 (2020) 108.
- [55] T. Dozat, Incorporating nesterov momentum into adam (2016).
- [56] E. Kauderer-Abrams, Quantifying translation-invariance in convolutional neural networks, *arXiv preprint arXiv:1801.01450* (2017).
- [57] A. De, A. S. Chowdhury, Dti based alzheimer's disease classification with rank modulated fusion of cnns and random forest, *Expert Systems with Applications* 169 (2021) 114338.
- [58] N. V. Chawla, K. W. Bowyer, L. O. Hall, W. P. Kegelmeyer, Smote: synthetic minority over-sampling technique, *Journal of artificial intelligence research* 16 (2002) 321–357.
- [59] M. Odusami, R. Maskeli unas, R. Damaševičius, and T. Krilavičius, "Analysis of features of alzheimer's disease: detection of early stage from functional brain changes in magnetic resonance images using a finetuned resnet18 network," *Diagnostics*, vol. 11, no. 6, p. 1071, 2021.
- [60] A. M. Alhassan, A. D. N. Initiative, A. I. Biomarkers, and L. F. S. of Ageing, "Enhanced fuzzy elephant herding optimization-based otsu segmentation and deep learning for alzheimer's disease diagnosis," *Mathematics*, vol. 10, no. 8, p. 1259, 2022.
- [61] M. Odusami, R. Maskeli unas, and R. Damaševičius, "An intelligent system for early recognition of alzheimer's disease using neuroimaging," *Sensors*, vol. 22, no. 3, p. 740, 2022.

...