

**Vol-3025****urn:nbn:de:0074-3025-0**

Copyright © 2021 for the individual papers by the papers' authors. Copyright © 2021 for the volume as a collection by its editors. This volume and its papers are published under the Creative Commons License Attribution 4.0 International ([CC BY 4.0](https://creativecommons.org/licenses/by/4.0/)).

teleXbe 2021

Technology Enhanced Learning Environments for Blended Education - The Italian E-Learning Conference 2021

**Proceedings of the Second Workshop on Technology Enhanced Learning
Environments for Blended Education - The Italian E-Learning Conference
2021**

Foggia, Italy, October 5-6, 2021.

Edited by

Pierpaolo Limone *

Raffaele Di Fuccio **

* University of Foggia, 71121 Foggia, Italy

** Smarted.srl, 80121 Naples, Italy

Institute of Cognitive Sciences and Technologies, National Research Council, 00185 Rome, Italy

Table of Contents

- teleXbe-2021 – The balance distance and face-to-face learning: a field for the discussion of scientific evidences
Pierpaolo Limone, Raffaele Di Fuccio
- Advanced teachers training in the remote mode
Alena Leshchenko, Alla Paziak, Olena Diahyleva, Mariia Masonkova, Alona Yurzhenko
- Use of digital instruments during processing of results of pedagogical research
Tetiana V. Polishchuk, Dariia A. Voznosymenko
- Technology: tool or learning object? Travels through two school-work alternation courses
Luigi Traetta
- Hybrid teaching in the experience of the University of Foggia: analysis, implementation and perspectives
Martina Rossi, Luigi Tateo
- Framing automatic grading techniques for open-ended questionnaires responses. A short survey
Gabriella Casalino, Barbara Cafarelli, Emiliano del Gobbo, Lara Fontanella, Luca Grilli, Alfonso Guarino, Pierpaolo Limone, Daniele Schicchi, Davide Taibi
- From the “pedagogy of innovation” to 3D technologies: Mechanical models for technical-scientific training
Marco Ceccarelli, Luigi Traetta
- Cultural capital during pandemic emergency: Preliminary data on how pandemic changed adults’ attitude towards reading for pleasure
Caterina Artuso, Paola Palladino
- User interface design for e-learning platform and institutional portal of University of Foggia
Lucia Borrelli, Sara Perrella
- Develop OERs for technology enhanced learning
Annaleda Mazzucato, Joanna Kic-Drgas
- E-Methodology toolbox: didactic methods for tutorial e-teaching on the example of students of a higher education institution in Austria
Mirela Müller, Vesna Josipović
- Gifted students: from identification to the use of educational technologies
Guendalina Peconio, Giuliana Nardacchione, Federica Doronzo
- Digital and analogue memory: a theoretical and historical framework for e-learning
Angela Arsena
- Teaching environment mediated by robot-assisted autism therapy (RAAT) to improve soft skills
Federica Doronzo, Giuliana Nardacchione, Guendalina Peconio
- Neurofeedback video games in the rehabilitative treatment of hyperactivity and

attention deficit disorder for attention enhancement and hyperactivity reduction

Giuliana Nardacchione, Federica Doronzo, Guendalina Peconio

- Models of teaching and learning: digital evolution during the Covid-19 pandemic

Dario Lombardi

- Online quantitative research methods: A scoping review on education, psychological factors in e-learning, and working from home

Giusi Antonia Toto, Pierpaolo Limone

- An innovative tool for olfactive learning with tangible user interfaces in MOOC learning for viticulture and enology learning

Raffaele Di Fuccio, Giusi Antonia Toto, Michela Ponticorvo, Anna Parola, Davide Marocco, Orazio Miglino

2021-11-08: submitted by Anna Parola, Raffaele Di Fuccio metadata incl. bibliographic data published under [Creative Commons CC0](#)

2021-11-28: published on CEUR Workshop Proceedings (CEUR-WS.org, ISSN 1613-0073) [[valid HTML5](#)]

From the “pedagogy of innovation” to 3D technologies: Mechanical models for technical-scientific training

Marco Ceccarelli^a and Luigi Traetta^b

^a *University of Rome Tor Vergata, Via del Politecnico 1, Roma 00133, Italy*

^b *University of Foggia, Via Arpi, 155/176, Foggia, 71121, Italy*

Abstract. This contribution analyzes the role of technology in the context of technical-scientific training, through the evolution, also from an historical perspective, of the mechanical models of mechanisms that have been used both to demonstrate the functionality of prototype solutions and to integrate laboratory didactics. Starting from the so-called “pedagogy of innovation”, which marked the birth of the modern engineering in the XVIII century, this essay explores the main concepts at the core of structural and applicative implementations in machines designs, with specific reference to technical-scientific training. The recent developments of 3D technologies, which allow to develop prototypes, even miniaturized ones, of complex machines that can be perfectly used in the context of training, confirm the importance of the role that technology-driven learning environments have been playing in the last few years.

Keywords 1

Pedagogy of innovation, technical training, mechanical models, 3D technologies

1. Introduction

The role of technologies in learning processes, which was widely acknowledged in the last thirty years, further consolidated during the COVID-19 pandemic, when the mediation of technologies was the only solution “to the emergency phase for all levels of training” [1]. This aspect, even if it has a primary importance [2], relegated to an almost marginal factor the contribution of technology, understood not so much as a tool which is capable of enhancing learning environments, but as an object of learning itself. Due to the emergency of technological literacy, which isn’t over yet despite several warnings which date back to over 20 years ago [3], the classic Technological Method (Sterry) is still relevant: it is based on the principle according to which technology extends human skills, because it’s “know how” combined with knowledge [4]. In fact, the concrete use of technology, understood as an object of learning which is capable of providing multidisciplinary skills, is invoked as a catalyst of skills in the other classic reference of scientific literature on the reform of specialist training [5].

However, the acknowledgment of knowledge, not only in its scientific dignity but also in its educational value – and, subsequently, as an object of communication and sharing – is quite recent. In fact, the combination of science and technology dates back to the Renaissance, as well as the subsequent reevaluation of the social prestige of engineers [6], whose professionalism became more and more essential for the economic progress. In this respect, one of the privileged sectors was the construction of machines and mechanisms which, since the XVIII century, has been treated systematically for didactic purposes.

Proceedings of the Second Workshop on Technology Enhanced Learning Environments for Blended Education, October 5–6, 2021, Foggia, Italy

EMAIL: marco.ceccarelli@uniroma2.it (A. 1); luigi.traetta@unifg.it (A. 2)

ORCID: 0000-0001-9388-4391 (A. 1); 0000-0001-7785-9751 (A. 2).



© 2021 Copyright for this paper by its authors.

Use permitted under Creative Commons License Attribution 4.0 International (CC BY 4.0).

CEUR Workshop Proceedings (CEUR-WS.org)

That brings us to the current situation, after a long journey [7]: in the mechanical engineering, mechanism models are often considered part of a study or design check in a design process, but they can be considered as an important means in teaching activity. In fact, in the history of engineering and science, mechanism models are not addressed specifically but they are considered complementary activities either in research, or design, or teaching. Sometimes, the history of science and technology is also explained by using them both in encyclopedic works, like for example in [8, 9], and in specific works in conferences and journals, like for example in paper at the HHM symposia like [10], as well as in didactic activities, as for example with LEGO packages [11]. Some specific attention is addressed to models of mechanism when considering their values for museum exhibition and historical contents as an attraction to past developments, as outlined for example in [12, 13, 14, 15].

2. The pedagogy of innovation and the birth of the modern engineer

Following the example of the *Royal Society* which, already in 1664, had obtained the privilege to assess the inventions of new machines, in 1675 Jean-Baptiste Colbert assigned to the *Académie des Sciences* the task of describing the main existing mechanisms in Europe. The “pedagogy of innovation” [16] was born: it consisted in the obligation, for inventors, to present their new machines to scientific societies, which became guarantors of authenticity and functionality in exchange for the right of ownership. In short, the growing awareness of how technology had become essential for the progress and wellbeing of humanity, was turning traditional mechanics into engineers who, however, were capable of describing the secrets of the machine to scientists, apprentices and to an educated audience – hence the pedagogical implications of the innovation. It’s a machine which, rather than continuing to “mask [...] the internal mechanisms with decorative coverings” [17], discloses its intimacy to the curious observer who, as prescribed by the emerging sensualist pedagogy, must be able to learn by observing and having fun.

In France, however, the relationship between engineers and scholars wasn’t entirely tension-free since, unlike other prestigious scientific institutions such as the *Royal Society* and the Academy of Cimento, the *Académie des Sciences* was born as an official government body and represented, therefore, the scientific-cultural manifestation of both centralised power and the “absolutist state’s bureaucratic [...] tendencies” [18].

Almost acting as the official judge of national science, with the power of promoting or rejecting the invention of a new machine, the *Académie* actually obtained full control over the engineers’ work, causing a feeling of rejection in them, which was driven by the awareness of their dual right: not only being able of independently managing their ideas, but also – and especially – “being judged by their peers, by people who consider mechanical problems from their same perspective, and not based on abstract theoretical considerations” [19].

After all, during the age of enlightenment, technology contributed to create conditions which were propaedeutic to next century’s industrial take-off. The real revolution of the XVII century, from a technological perspective, wasn’t really about the machines: it was about the tools, which reached a very high level of perfection and became essential for the affirmation of the “direct learning” of artisans, who were able to read by then [20]. In Chaunu’s thesis, there is no conflict between the tools of the XVIII century and the machines of the XIX century: in fact, the artisans’ ability to interact with designers, along with the diffusion of *Encyclopédies* and “technical schools”, was the premise for the XIX century’s technological development, based on increasingly complex levels of practical intelligence and skills.

However, in the XVIII century, the most intense moments for sharing technological knowledge remained the very popular public demonstrations – just think of plays of light or balloon flights – which consolidated the trend of living progress as a “wonderful” world, a kind of *fiction* that could simply be approached without having to understand. Even literature encountered popular technology, in a crescendo which led several so-called inventors of the time to seek their fortune, by engaging in “a few popular scientific publications which, actually, were manuals for magicians” [21].

The arrival of the new century profoundly changed, also from a popular perspective, the image of technology, starting from the “number of industries where technology was one (we could almost say

the only) dynamic strength” [22]. The application to the textile industry of James Watt’s steam engine allowed to automate the movement of looms’ wheels which, until then, had depended on the strength of arms or flowing water, whereas the mechanical loom, introduced in 1785 by Edmund Cartwright, allowed to further speed up the production of fabrics.

The steam engine freed the factory both from the geographical constraints of proximity to natural energy sources – water or wind strength – and from seasonal constraints, such as drought or floods of rivers, and opened the way to a way of producing where the old workshop, which was based on the work of one artisan, was losing its meaning. The start of the XIX not only coincided with the so-called “age of cotton”: metallurgy, mechanical industry, construction industry and industrial chemistry gradually established themselves, along with technological development.

The topic of professional training became, therefore, increasingly urgent due to industrial revolution: the use of machines in industries required a specific, intentional education and, because of it, the domestic transfer of knowledge on the correct use of tools, which could previously be passed on from father to son, became more and more insufficient.

3. The mechanical models of mechanisms

A mechanism is a mechanical system composed of several bodies in relative motion whose aims is to transmit motion and force, as per definition given for example in standard terminology [23] and textbooks like [24]. In general a mechanism can be considered a key component in machine as per its function in converting mechanical energy to a proper level for a task. In such a scheme it is also possible to recognize a modelling of a mechanism not only for design purposes but also for explaining the functioning of the whole machine and specifically the operation as per an intended task. Thus, a mechanism model can be elaborated for design, simulation and exhibition purposes with solutions that span today from virtual solutions in computer-oriented software packages to scaled simplified mechanical constructions up to well defined prototypes or demonstrators, even referring to the same design as an evolution of the definition of the solution. An example is illustrated in fig. 1 referring to a linkage as a motion assisting exoskeleton for fingers, [25, 26] in which the model is designed with a kinematic diagram in a), with a CAD solution in b) and with a lab prototype in c). The kinematic diagram is aimed both to explain the design structure and basic parameter of the solution, the CAD design is used to define the details of the mechanical design and the feasibility of its operation, and the prototype is used for design validation and testing the operation performance, with activity spanning from teaching to design up exhibition.

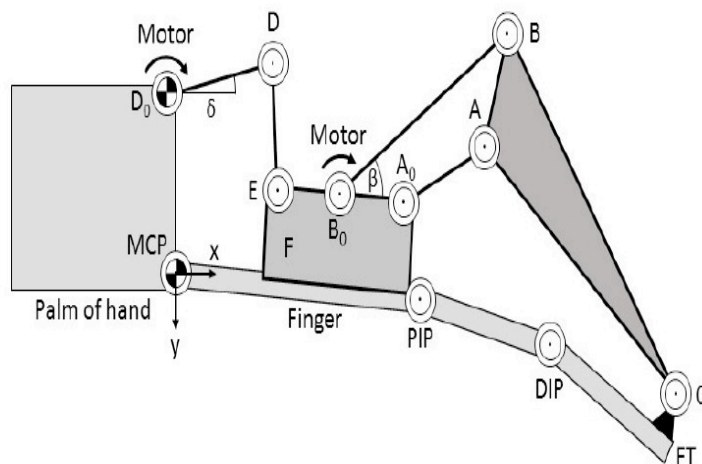

Figure 1a: kinematic model for design algorithms

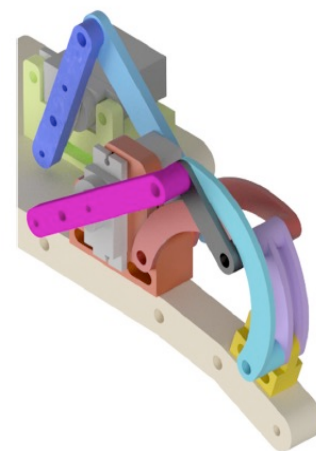

Figure 2b: CAD model for simulation

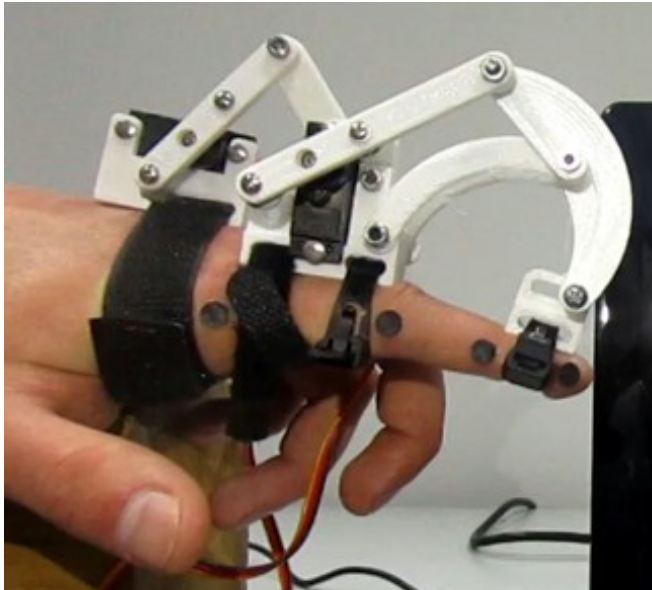

Figure 3c: lab prototype for testing

In general, since the past mechanism models are used in a variety of activities for teaching, study, research and design as demonstrative illustrations and presentations of validation and operation characterization, including experimental check, and even promotion or market exhibition. They are developed and used not only for mechanical systems, but even as means or part of systems in other disciplines, with similar aims or complementary purposes of service as for example indicated in Ceccarelli (2012) [27].

4. Examples from the training on mechanical engineering

Since ancient times, the design and characterization of the functionality of mechanisms in machines have been studied and elaborated using models of various kinds not only for design purposes in dimensional determinations aimed at construction but also to motivate and explain the efficiency of the proposed solutions both to clients and general public. The models generally used can be identified in graphic schemes more or less accompanied by mathematical models and relative numerical calculations but also by physical-mechanical models with realizations both in full size in the form of prototype products and in scale for purposes of first study and explanation of the proposed solutions. Unfortunately, there is no physical evidence left of the models of antiquity except literature sources which in any case have come to us without the original drawings of these models. One can refer, for example, to the work of Archimedes, [28] and Roman engineers, among all the work of Vitruvius, [29] whose specific studies on machines and mechanisms were then rediscovered during the Renaissance and republished also with sets of figures and graphic schemes resulting from interpretations of the text and the direct experience of the authors of the reproductions. Among all it is worth mentioning the work of Guidobaldo del Monte, [30], who refreshed the work of Archimedes in examining the mechanics of machines by referring to elementary machines with interpretative schemes but also basic for numerical formulations which were elaborated again by Galileo Galilei in the first cycle of lectures held at the University of Padua [31], as collected in the first text specifically dedicated to the teaching on design of machines and mechanisms that were conceived and designed throughout the Renaissance by engineers and early mechanical mechanics scientists [32]. The example of fig. 2 represents one of these schemes in the form of a model of elementary machines in which the mechanical structure is represented in an essential form both for the design and functionality of the mechanism of a screw body.

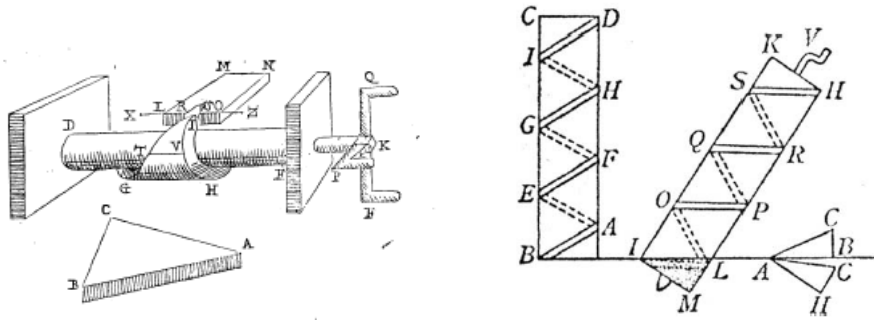

Fig. 2: Example of a graphic model of an elementary machine of Archimedean modeling from: a) *mechanicorum liber* by Guidubaldo del Monte [33]; b) the lecture treatise by Galileo Galilei [34].

Subsequently, this didactic-demonstrative purpose of graphic models of the machines had its frame in the *Theatrum Machinarum* in the form of catalogs of machines in which the structures of the machines are represented with an accompanying text for a description of the functionality and construction peculiarities. This didactic-illustrative purpose has developed since the first machine manuals of Francesco di Giorgio, [35], of the early Renaissance up to the elaboration of complex catalogs in the form of the *Theatrum Machinarum* and finally also in specific encyclopedia chapters like in the D'Alembert and Diderot encyclopedia.

Close to the development of the industrial revolution, these catalogs have specialized in the representation of graphic models of mechanisms within specific treaties such as the pioneering one conceived by Gaspard Monge and written by Lanz and Betancourt under the guidance of Hachette (immediately translated into Italian for educational and professional use) whereas it was revised and further developed in the first European manual (Italian) by Giuseppe Antonio Borgnis [36], as represented in the example of fig. 3 in which the modeling of mechanisms is also represented with the aim of explaining a classification of the structural and functional possibilities of the various types of mechanisms. These aims for design and teaching activities have given rise to a specific literature and also to a research aimed at discovering unitary principles in the variety of mechanisms according to the various types also with the help of small-scale models that have seen full success with the production of models designed by Franz Reuleaux produced by the Voigt company with planetary circulation.

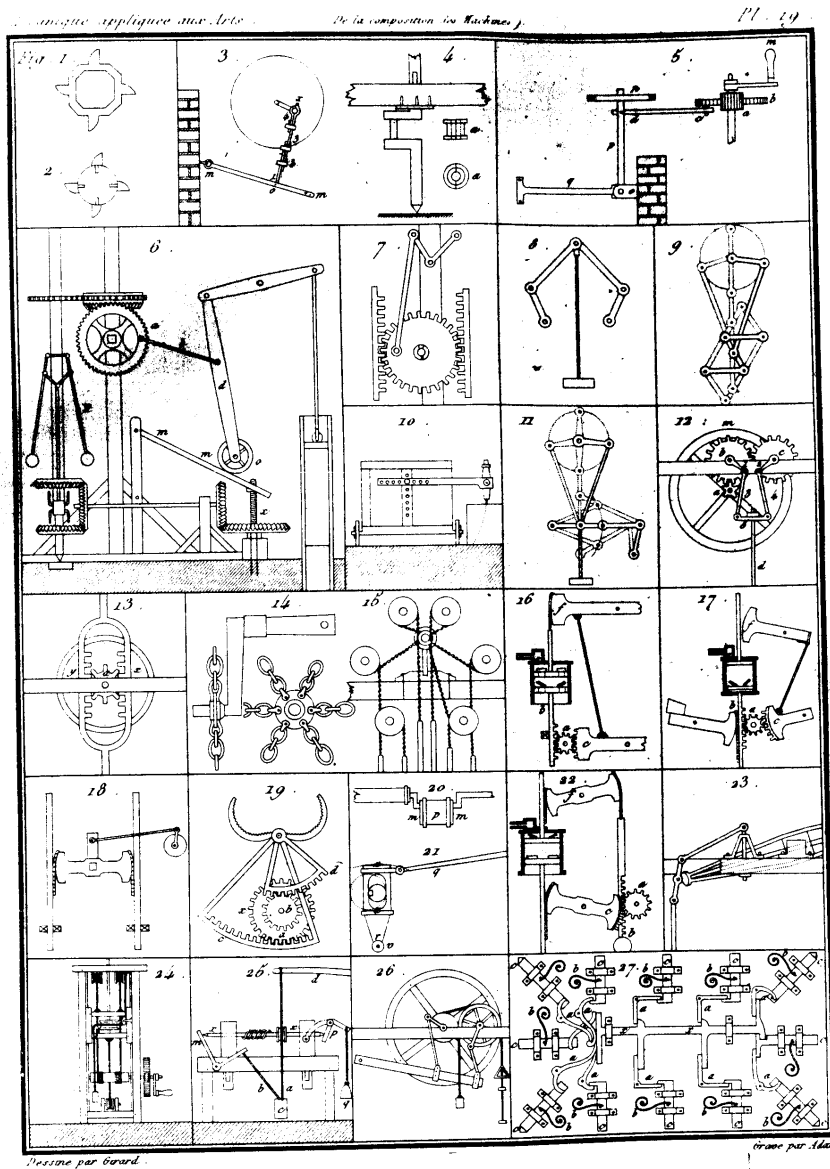

Fig. 3: Example of graphic modeling of mechanisms in classifications from the work of Borgnis in Pavia in 1823, [37].

In particular, in Italy this activity has seen a production of specific literature right from the first courses dedicated to the training of mechanical engineers at the University of Turin which later became the Polytechnic of Turin with Professor Carlo Giulio with his work that incorporates the didactic study by Gaspard Monge developed further by Robert Willis and continued throughout the nineteenth century until reaching the work of Francesco Masi [38] at the University of Bologna, with his encyclopedic treatise [39] in which the modeling of mechanisms is treated not only at the graphic level but also at the level analytic-formulistic as represented in fig. 3.

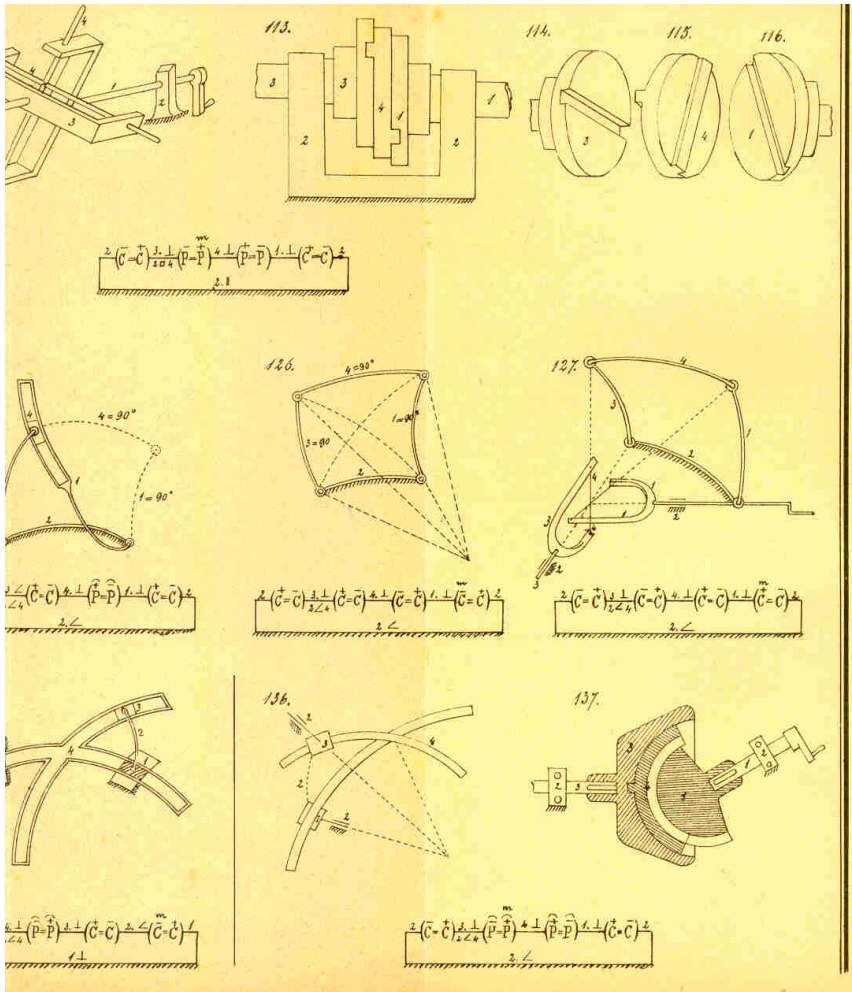

Fig. 4: Example of graphic-analytical models of mechanisms from the work of Francesco Masi [39] in Bologna at the end of the 19th century

Obviously, this development of graphic models for analytical formulations for the purpose of analysis and teaching of the functionality of the mechanisms were also accompanied by products of various types of physical-mechanical models, both in scale with emulation of Voigt models and models specifically designed by the Italian teachers of the courses. Fig. 5 shows examples of such physical-mechanical models that were produced from the end of the 20th century up to the 60s of the 20th century with evident didactic purposes for courses in the study of kinematics and the design of mechanisms for even more complex machines. Fig. 5 shows an example of the dissemination of models in the whole national frames as preserved respectively in the Polytechnic of Turin, in the University of Rome, in the Polytechnic of Milan, and in the University of Palermo with mechanical construction structures respectively in metal, wood, and combination of materials to represent as such modeling also for didactic purposes has been produced with a great variety of solutions.



a)



b)



c)

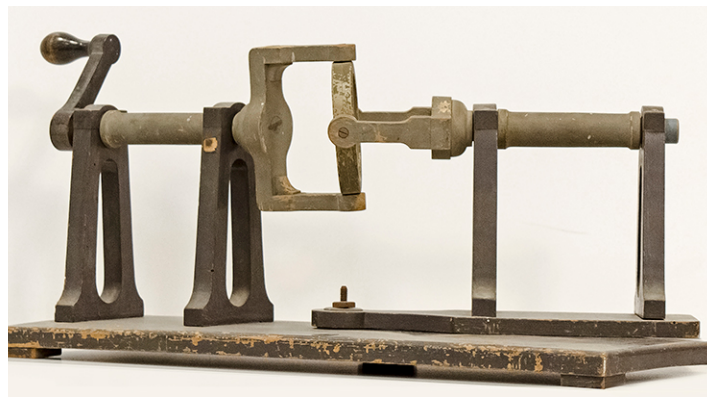

d)

Fig. 5: Examples of physical-mechanical models of mechanisms for didactic purposes in the 20th century at: a) Politecnico di Torino; b) University of Rome; c) Politecnico di Milano; d) University of Palermo [40].

In the 1980s-90s, the advent of computers and related computerized modeling technologies produced virtual models that are still used today in courses to explain the structures of mechanisms and their functionality with dedicated algorithms for a virtual simulation of their performance and numerical representation as a characterization of the principles and solutions proposed and further developments for even innovative designs. In this process, there are not conceptual advantages, but only practical convenience.

Subsequently, at the beginning of this century, didactic techniques have been developed for the study of mechanisms and machines that combine the various types of modeling described above, i.e. graphic, physical-mechanical, virtual computerized ones, in such a way that the trainee in training for not only mechanical engineering of machines with mechatronic solutions can appreciate not only the structure and mechanical functionality typical of man-machine and machine-machine interaction but also the integration with further systems from other disciplines that are now essential in the structure modern mechatronics of a machine and a mechanism or by combining various types of drives, control systems and sensorization necessary for the regulation of the machines according to the applications to which they are dedicated and designed.

5. Conclusions

Although today the teaching and design techniques are based on computer-assisted modeling and therefore based on a mathematical and simulation modeling, the realization of physical-mechanical

models (in wood, metal, plexiglass, 3D printing ABS or PLA) is once again considered necessary and fundamental for a rational training and efficient to develop adequate knowledge and awareness of the problems of the solutions that an engineer must face for the development and management of mechanisms and machines with a mechatronic structure for correct and efficient operation in the most modern current uses.

6. References

- [1] G. A. Toto, P. Limone, Motivation, Stress and Impact of Online Teaching on Italian Teachers during COVID-19, *Computers*, 10.75, 2021 <https://doi.org/10.3390/computers10060075>
- [2] G. A. Toto, P. Limone, (2021) From Resistance to Digital Technologies in the Context of the Reaction to Distance Learning in the School Context during COVID-19, *Education Sciences*, 11.4, 2021.
- [3] E. N. Savage, A Conceptual Framework for Technology Education: A Historical Perspective, *The Journal of Technology Studies*, 28, 2002: 98-100.
- [4] L. Sterry, R. Hendricks, *Exploring technology*, Menomonie, WI, T&E Publications, 1999.
- [5] B. Means, K. Olson, *Technology and Education Reform: Studies of Education Reform*, Washington, Diane Publishing, 1997.
- [6] P. Rossi, *I filosofi e le macchine. 1400-1700*, Milano, Feltrinelli, 2009.
- [7] P. Limone, Towards a hybrid ecosystem of blended learning within university Contexts, *CEUR Workshop Proceedings*, Vol. 2817, 2021.
- [8] A. Capocaccia, (Ed.), *History of technique. From Prehistory to the Year One Thousand*, Turin, UTET, 1973.
- [9] C. Singer et al. (Eds.), *History of technology*, Vol. 2. Turin, Boringhieri, 2012.
- [10] B. Zahang, M. Ceccarelli (Eds.), *Exploration in in the History and Heritage of Machines and Mechanisms – Proceedings of HMM2018*, Springer Nature Switzerland AG, Cham, 2019.
- [11] LEGO, *Lego Education*, 2019 (<https://education.lego.com/en-gb>).
- [12] M. Ceccarelli, *Mechanism Designs of Cultural Heritage*, 13th World Congress in Mechanism and Machine Science IFToMM 2011, Guanajuato, 2011, paper n. A2 I-393.
- [13] H. Kerle, K. Mauersberger, and M. Ceccarelli, *Historical Remarks on Past Model Collections of Machines and Mechanisms in Europe*, 13th World Congress in Mechanism and Machine Science IFToMM 2011, Guanajuato, 2011, paper n. A2 I-279.
- [14] M. Ceccarelli, *Considerations on Mechanism Designs as Suitable for Cultural Heritage Evaluation*, *Advances in Historical Studies*, 2.4, 2013, <http://dx.doi.org/10.4236/ahs.2013.24022>.
- [15] M. Ceccarelli, *Models of mechanisms for teaching and experimental activity*, *Atti del XXXVIII Convegno annuale Società Italiana degli Storici della Fisica e dell'Astronomia*, Pavia University Press, Pavia, 2020.
- [16] M. Ceccarelli, *Figures and achievements in MMS as landmarks in history of MMS for inspiration of IFToMM activity*, *Mechanism and Machine Theory*, Volume I, 05, 2016.
- [17] L. Dolza, *Storia della tecnologia*, Il Mulino, Bologna, 2008.
- [18] J. Riskin, *Physique amusante. Dimostrazioni e intrattenimento*, in S. Petruccioli (Ed.), *Storia della scienza*, vol. VI L'Età dei Lumi, Treccani, Roma 2002.
- [19] R. Hahn, *The Anatomy of a Scientific Institution: The Paris Academy of Sciences, 1666-1803*, University of California Press, Berkeley, 1971.
- [20] C. C. Gillispie, *The Encyclopédie and the Jacobin Philosophy of Science*, in M. Clagett (Ed.), *Critical Problems in the History of Science*, University of Wisconsin Press, Madison, 1959.
- [21] P. Chaunu, *La civiltà dell'Europa dei Lumi*, Il Mulino, Bologna, 1987.
- [22] R. Darnton, *Mesmerism and the End of the Enlightenment in France*, Harvard University Press, Cambridge, 1968.
- [23] C. Wilson, *Technology and Industrial Organization*, in C. Singer et al. (Eds.), *A history of technology*, vol. 5, Oxford University, London, 1954-1984.

- [24] IFToMM, Special Issue: Standardization and Terminology. - Mechanism and Machine Theory, vol.38, 7.10, 2003.
- [25] J. J. Uicker, G. R. Pennock, J. E. Shigley, Theory of Machines and Mechanisms, Oxford University Press, Oxford, 2017.
- [26] C. S. Lopez-Cajùn, M. Ceccarelli, Mecanismos: Fundamentos cinematicos para el diseno y la optimizacion de la maquinaria, Trillas, Ciudad de Mexico, 2013.
- [27] M. Ceccarelli, An Outline of History of Mechanism Design in servicing Science, in Physics, Astronomy and Engineering: critical problems in the History of Science and Society- Pro c. of SISFA 2012, The Scientia Socialis Press Siauliai, (Invited lecture): 1-10.
- [28] M. Ceccarelli, Contributions of Archimedes on mechanics and design of mechanisms, Mechanism and Machine Theory, 72, 2014 <http://dx.doi.org/10.1016/j.mechmachtheory.2013.10.005>.
- [29] M. Cigola, M. Ceccarelli, Marcus Vitruvius Pollio (Second Half of the 1st Century B.C.), in: Distinguished Figures in Mechanism and Machine Science - Part 3, History of Mechanism and Machine Science, Volume 26, 2014, <http://dx.doi.org/10.1007/978-94-017-8947-9-15>.
- [30] G. Del Monte, Mechanicorum Liber, Apud Hieronymum Concordiam, Pisauri, 1577.
- [31] M. Ceccarelli, "Early TMM in Le Mecaniche by Galileo Galilei in I 593", Mechanisms and Machine Theory, 41.12, 2006: 1401-1406.
- [32] M. Ceccarelli, Renaissance of Machines in Italy: from Brunelleschi to Galilei through Francesco di Giorgio and Leonardo, Mechanism and Machine Theory, 43, 2008: 1530-1542.
- [33] G. Del Monte, Mechanicorum Liber, Apud Hieronymum Concordiam, Pisauri, 1577.
- [34] M. Ceccarelli, "Early TMM in Le Mecaniche by Galileo Galilei in I 593", Mechanisms and Machine Theory, 41.12, 2006: 1401-1406.
- [35] M. Ceccarelli, Contributions of Francesco di Giorgio, in Mechanism Design, Anales de Ingeniería Mecánica, Año 21, Madrid, Septiembre 2018.
- [36] M. Ceccarelli, Giuseppe Antonio Borgnis (1781- 1863), in: Distinguished Figures in Mechanism and Machine Science, Part 3, History of Mechanism and Machine Science, Volume 26, 2014, <http://dx.doi.org/10.1007/978-94-017-8947-9-3>.
- [37] G. A. Borgnis, De la composition des machines, Bachelier, Paris, 1818.
- [38] M. Ceccarelli, 'Francesco Masi (1852-1944)', Distinguished Figures in Mechanism and Machine Science: Their Contributions and Legacies - Part 2, Book series on History of Machines and Machine Science, Vol.7 , Springer, Dordrecht, 2010, DOI 10.1007/978-90-481-2346-9-8.
- [39] F. Masi, Manuale di cinematica applicata: Nuova classificazione dei meccanismi, Zanichelli, Bologna, 1883.
- [40] M. Ceccarelli, C. Morales-Cruz, A prototype characterization of ExoFinger, a finger exoskeleton, International Journal of Advanced Robotic Systems, May-June 2021: 1-8, DOI: 10.1177/17298814211024880.