

ss. B 486

DOCTORAL THESIS

- I. AUTOMATION IN CLINICAL CHEMISTRY.

- II. AN AUTOMATED FLUOROMETRIC METHOD FOR DETERMINATION
OF α -HYDROXYBUTYRIC DEHYDROGENASE.

LASZLO SARKOZI

SZEGED, 1970

B H86

CONTENTS



Diss. B H86



Association in Clinical Chemistry

1. A. The Problem
- B. The Purpose of the Study
- Relative Methods
 1. Costs
 2. Dimensions
 3. Vertical or Horizontal
 4. Speed
 5. Precision and Accuracy
 6. Sample Size
 7. Ease of Operation
 8. Replacement
 9. The Interference
 10. Reagents and Accessories
 11. Labor
 12. Compatibility
 13. Data Handling
- The Effects of Automation
 1. Personal and Cost
 2. Quality Control
 3. Admission Profiles, Population Demographics
- Types of Automated Systems
 1. Individual Reaction Vessel for each Sample
 - a. The Robots
 - b. The Analytic Packs
 - c. Centrifugal Systems
 2. Continuous Flow System
 3. Automated Clinical Chemistry Systems Available Commercially
2. The Necessary and Desirable Tests in Automated Clinical Chemistry

CONTENT

- I. Automation in Clinical Chemistry.
 1. A. Introduction
B. The Purpose of Automation
 2. Decisive Factors
 - A. Costs
 - B. Dimensions
 - C. Vertical Or Horizontal Test Requests
 - D. Speed
 - E. Precision and Reproducibility
 - F. Sample Size
 - G. Ease of Operation
 - H. Replacement Parts and Service
 - I. The Emergency Exit
 - J. Reagents and Supplies
 - K. Labor
 - L. Compatibility
 - M. Data Handling
 3. The Effects of Automation
 - A. Personnel and Cost
 - B. Quality Control
 - C. Admission Profiles, Population Screening
 4. Types of Automated Systems
 - A. Individual Reaction Vessel for Each Sample
 - a. The Robots
 - b. The Analytic Packs
 - c. Centrifugal Systems
 - B. Continuous Flow System
 - C. Automated Clinical Chemistry Systems Available Commercially
 5. The Necessary and Desirable Trends in Automated Clinical Chemistry

II. An Automated Fluorometric Method for Determination of α -Hydroxybutyric Dehydrogenase.

1. Introduction
2. Existing Methods
 - A. Manual
 - a. Colorimetric
 - b. Spectrophotometric
 - c. Fluorometric
 - B. Automated
 - a. Analytic Packs
 - b. Centrifugal System
 - c. Continuous Flow System
 - C. Advantages of the Fluorometric Measurements
3. Proposed Method
 - A. Selection of a New Method
 - B. Principle
 - C. Equipment
 - D. Reagents
 - E. Procedure
 - F. Standardization
 - G. The Effect of Different Variables
 - H. Reproducibility
 - I. Recovery
 - J. Serum Blank
 - K. Maintenance, Troubleshooting
 - L. Comparison of Methods
4. Clinical Evaluation
5. Summary

I.

A. Part I of this work intends to help the Clinical Chemist, who faces the problems of the ever increasing workload or who is about to organize a routine or research laboratory.

Clinical Chemistry utilizes all the advances and developments of instrumental analytical chemistry. The present day instrumentation provides fast, sensitive and specific measurements of different physical properties of substances (elements and/or compounds). These instruments combined with mechanical and electronic devices can be automated.

There are two questions to be answered: When to automate and how? Before answering any of them, there are several factors to be considered. To answer the first question, I utilize my years of experience in automated Clinical Chemistry and without going into specific details, I will try to point out all the aspects of Laboratory Management that will influence the proper evaluation. Every institution or laboratory has its own idiosyncrasies, but there are several situations in common, some generalization is possible.

For answering the second question I conducted a

market survey inclusive May, 1970. For individuals without experience in automation, I grouped the commercially available systems according to the principles utilized by the manufacturers. This may be an over simplification, because, e.g. the AGA Robotchemist or the Bausch and Lomb ZYMAT 340 have very little in common but nevertheless my classification is valid and it helps the understanding of their operation. To choose the proper systems, one will have to obtain their exact specifications and descriptions. Compiling this information I was overwhelmed by the complexity and simplicity of these systems. The difficult decision should be the responsibility of the well informed Chemists.

B. THE PURPOSE OF AUTOMATION.

During the last 10-15 years the number of requested and performed quantitative analytical tests multiplied several times. The available pool of trained chemists and technicians was greatly insufficient to complete this workload with the classical manual procedures. In some industrial areas semi-automatic methods of analysis were introduced to decrease this burden.

Probably the most dramatic increase is in Clinical Chemistry. Statistics taken from available records show that our Department of Chemistry performed 240,000 tests in 1965 and by 1969 this number surpassed the 1,000,000 mark. Previously some attempts were made to automate certain steps, i.e. sampling, dilution, aspirating into the cuvette of the colorimeters, but the real breakthrough came in 1957 when Skeggs published his completely automatic continuous flow method of colorimetric analysis^{1.}

During the years it was proven that automated analysis is at least or more accurate than the manual procedures and the reproducibility is far more superior than the best manual techniques. An other great advantage of the automated analysis is the permanent recording of the test results. This provides easy verification and control of the calculations, eliminating certain human errors.

Although there is a significant capital outlay, it is counter-balanced by the decreasing cost per tests (estimated at 5%-30% of the manual cost^{2.}), the efficiency increases and the sometimes very critical speed of the determinations is also a significant factor.

Automation provides maximum utilization of the professional and technical manpower by decreasing the daily

routine workload and freeing time for more sophisticated work. The availability, efficiency and the reduced cost of battery of tests will provide large scale screening programs in preventive medicine, early detection and cure of diseases and an improved public health service.

2. DECISIVE FACTORS.

A. COSTS.

The range is from \$2,500 to \$250,000. Some systems start with the basic arrangement and its capacity and performance can be expanded. Others are constructed as almost complete and final systems. The cost of the capital investment and the cost per test have to be evaluated independently. While one of them fits the requirement, the other can make it prohibited for a logical choice. The amortization factor given by manufacturers most of the time is not realistic because the equipment may become obsolete long before the life expectancy.

B. DIMENSIONS.

There is a general limitation set by the available space in the laboratory. With the increased workload in quantity and in the variety of the available tests, previously designed and allotted areas become overcrowded with people and instruments. However, introducing automation will result in the elimination of some manual procedures and it makes space for itself.

C. VERTICAL OR HORIZONTAL TEST REQUESTS.

Large volumes of repetitive performance of the same test or a very few number of tests versus a wide range of tests. If one determination has to be performed most of the time a single channel system is the most efficient and economical. The number of channels can be increased by additional single units. There is a point of expansion when simultaneous multi-channel systems are the logical choice.

D. SPEED.

Depending on the field of application a fast, approximate answer may be more valuable than an exact but time consuming performance.

E. PRECISION AND REPRODUCIBILITY.

In some specific areas the significant difference may be much smaller than in others. It has to be defined what is the acceptable coefficient of variation, standard deviation, and any improvement has to be in proportion

with the invested cost and effort.

F. SAMPLE SIZE.

It is important to consider the required amount of sample per test or battery of tests. In most cases, it is not a limiting factor. The majority of the tests can be performed on less than 0.1 ml of serum. In specific cases (Pediatrics, Geriatrics) there is a very limited supply of blood; tests are requested on specimens obtained by finger stick or heel stick instead of vein puncture. Some systems are able to perform tests on ultramicro scale, on 0.001-0.050 ml of sample. The future trend is definitely in favor of the ultramicro determinations.

G. EASE OF OPERATION.

The operator of automated equipment must possess a basic knowledge of the mechanics and possibly the electronics of the system. A preventive maintenance and experience in troubleshooting will eliminate or minimize the "downtime" of any automatic analyzer. The degree of sophistication of the system being considered for appli-

cation has to be in proportion with the quality of the available personnel.

H. REPLACEMENT PARTS AND SERVICE.

An automated system will break down periodically. If the function of the system is to provide results within a given time, the speed of the repair is critical. More of the breakdowns can be corrected by the staff of the laboratory. Supplies of frequently needed replacement parts is mandatory. Other more expensive parts have to be supplied by manufacturers within reasonable time either if as a replacement or as a loan unit to provide service during a time consuming repair. A laboratory might have well-trained chemists and engineers on its staff but in certain cases they still will have to call the factory for their servicemen. Their availability has to be considered also.

I. THE EMERGENCY EXIT.

At the planning stage of an automated laboratory it is important to look at a possible situation when the

chips are down. If the function of the laboratory is to provide emergency service also, some alternate automated, semi-automated or manual procedures have to be available to complete the work no matter what. An extreme situation was presented in the New York blackout when there was no electricity in the whole city for several hours. Laboratory equipment such as centrifuge, heating bath, colorimeters, which are working on alternate current were useless. For this possibility some generators or batteries have to be installed and/or some basic equipment working on direct current should be available.

J. REAGENTS AND SUPPLIES.

The quality and costs of the reagents and supplies have to be evaluated. If there are proper facilities available, some homemade reagents represent significant savings. If the reagent consumption is an insignificant factor in the costs per test calculation and the quality of the commercial reagent is acceptable, the invested time and space will not be in proportion with the returns. There is a healthy competition in the market of reagents and supplies making a good qualitative and economical

choice rewarding.

K. LABOR.

As the report of the conference held on Automation and Clinical Chemistry in Rougemont, North Carolina in 1966 concluded correctly, "Automation brings about increased efficiency per technician hour...if the workload is above a minimal level. However, in practice it has been found that the gains in efficiency usually have been offset by requests for a larger quantity of workload. The only result meant increases rather than decreases in manpower needs for the clinical laboratory." Any claim or commitment can be made only for the long run. An automated laboratory will absorb a large increase of workload with minimal additional expenses but the immediate laboratory requirement will not decrease.

L. COMPATIBILITY.

At some phase of the automation a master plan should be worked out. From the basic units to the multi-channel complex every system will have to fit into the complete

organization. If a system has one specific function only this may be short term or long term. Any long term investment is part of the complex, this will have to be coordinated. Equipment has to complement or substitute each other. They have to be able to link together to provide the System. Duplicated methodologies should give results in identical units with similar normal ranges⁴. The automated equipment has to have interfacing ability with the existing or planned computer facilities.

M. DATA HANDLING.

The speed and quantity of data obtained by the automated systems demands some electronic data handling devices to perform vital operations⁵. These include correction of base line drift, linearity, calculation of concentration and digital conversion, storage and retrieving of the data, statistical analysis, quality control, compatibility of patient data with previous results, cumulative reporting.

There are small special purpose computers, medium size general and large installations. The choice depends on the planned application. In Clinical Chemistry, a

medium sized general computer seems to be a logical and most practical answer. Some special purpose computers will give only temporary relief and provides limited service. Large computer installations will have to be shared with other laboratories or institutions, and are not designed specifically for laboratories and the operating personnel will not give priority to the laboratories. Any breakdown in its function will result in chaotic "manual" data handling and mishandling. A medium size dedicated laboratory computer on the premises will give the optimal service. All programs will be created according to the needs of the laboratory and the results, corrections and warnings are monitored by laboratory personnel. Data for further processing can be transferred to central computers.

3. THE EFFECTS OF AUTOMATION.

After the slow start in 1957 there was a significant interest by the middle of the sixties creating the present day explosion. Its effect is tremendous and has opened unlimited possibilities.

The immediate effect is felt in several areas.

A. PERSONNEL AND COST.

In our Department in 1965 some of the tests were automated. In 1966 additional automation was introduced and by 1967, 75% of the workload was performed on automated systems. Some comparison is shown in Table I.

TABLE I

	1965	1969
Number of Tests Performed	240,000	1,094,000
Employee Performed Tests and Data Handling	29	32
Tests Per Staff Per Year	8,275	35,008

Capital investment in automation for the above period was equivalent to three technician salaries for five years. On this basis the corrected number for 1969 is 31,257 tests per staff per year.

Taking the 1965 figures as 100%, the number of tests performed in 1969 increased to 456% and the same time the increase in staff including the cost of additional automation rose only by 12%.

A conservative estimate based on a survey conducted at the NIH Clinical Center shows that in a medium sized 500 bed hospital the failure to automate may cost ten to fifteen million dollars in a period of 15 years mainly because of the cost of added personnel which may constitute up to 80% of the total cost.

Regarding the training of personnel for the automated or, as a matter of fact, any laboratory, I would like to emphasize two specific points.

a. THE SIGNIFICANT DIFFERENCE.

One of our chemists reported routine Uric Acid values to the third decimal. When I inquired how could he arrive to these values with our method, he explained that he was not satisfied with the reproducibility (5.2 and 5.3 mg%), therefore, he performed the tests in triplicate and accepted the average of the values. This report is misleading because the error of the method is 2-5%, on the other-hand the invested time and effort was not necessary because a change of 0.2 to 0.3 mg% has no clinical significance.

One technologist prepared a reagent by mixing acids in the ratio of 2:1. To make one liter she carefully measured 666.66 ml and 333.33 ml and was concerned about the 0.01 ml she did not divide.

In exercising judgment one has to know what makes the difference. I just could not attack this problem by creating a generous approach because, e.g., measuring blood pH to the first decimal does not give the necessary information.

b. TROUBLESHOOTING.

The training of personnel for medical technology and specifically for Clinical Chemistry should be more practical including automated techniques, instruments and troubleshooting. These are additional requirements, because only a combined experience in chemistry, mechanics, physics and basic electronics will be able to solve most of the breakdowns in an automated laboratory. To troubleshoot on a "hit or miss" basis can be very time consuming and expensive. Only by a systematic, logical examination of the problems can they be solved.

B. QUALITY CONTROL.

The automation of large volumes of tests have introduced some other industrial methods to Clinical Chemistry. The quality control became a way of life. Every batch of specimens are accompanied by control samples. Acceptance or rejection of the test results mainly depend on the controls. They also serve as a check on the instruments' functions as well as on reagents and possible human errors.

C. ADMISSION PROFILES, POPULATION SCREENING.

For generations Clinical Chemistry tests were requested after physical examination and exhaustive search, in every case, to confirm the provisional diagnosis. These tests were time consuming and expensive and the physicians were very co-operative in limiting the number of tests to a minimum by being specific and selective with their requests.

Multichannel automatic analyzer first described by Skeggs and Hochstrasser⁶. in a sequential manner for 8 tests and expanded to a simultaneous 10 channel analyzer by Thiers, et. al.⁷. has changed this philosophy.

During 1968 our hospital introduced a new admission screening program. Accordingly every patient entering the hospital receives a "12 channel admission profile" from the Chemistry Department, and this serves as a preliminary data along with the original history and physical examination, assisting the diagnosis. The most common diseases of the liver, kidney, bone and parathyroid can be detected by these tests. A considerable number of unsuspected diseases were diagnosed while still in the early stages. Bryan, et. al.⁸. found that about 15% of the abnormal

findings were unexpected and in most cases it resulted in substantially earlier institution of important therapy.

In our Medical Center the following tests were chosen as New Admission Profile. Electrolytes (Na, K, CO₂, Cl, Ca) play major roles in maintaining acid-base balance. The levels of these constituents are followed in treatment of patients with diabetes, heart failure, also in pre- and post-surgical cases. Blood sugar is directly concerned with carbohydrate metabolism, becomes a test of the pancreas and liver function, which is particularly important in treating diabetes. Blood urea nitrogen is an indicator of kidney function and is vital in detecting early impairment. Measurements of bilirubin, a bile pigment, shows the pressure and degree of jaundice, and is of great value in the diagnosis of liver disease. Blood albumin analysis aids physicians in interpreting altered protein content. With blood enzyme studies (SGOT, Alkaline Phosphatase, LDH, CPK) detection of bone destruction by cancer is facilitated as well as diagnosis of heart and liver diseases.

4. TYPES OF AUTOMATED SYSTEMS.

In this survey, dozens of semi-automated systems will not be mentioned. There are numerous manufacturers whose systems require manual preparation of the reaction mixture and only the reading, recording of the test results are automated. Systems under discussion perform all the steps from sampling specimens through recording the test results. The only exception is the GEMSAEC System³, because of its unusual approach and its great potential. In addition, certain systems may have been left out unintentionally due to lack of information as of today. In these cases I have to apologize and as soon as I acquire knowledge on the availability of any additional systems, I will make the necessary corrections in all further communications.

A. INDIVIDUAL REACTION VESSEL FOR EACH SAMPLE.

a. THE ROBOTS.

Sample withdrawal, dispensing and reaction dispensing by precalibrated or adjustable piston pumps or syringes.

The sample is aspirated from a turntable or a magazine and dispensed into a container. The container is mechanically transported either by a conveyor system or turntable to each processing station. (See Figure 1.)

The proper dilution is made and the reagents are added at a given time and point of the particular methodology. After mixing, heating, incubation, cooling, the reaction mixture is transferred into a sensing module which can be anything employed in instrumental analysis

FIGURE 1.

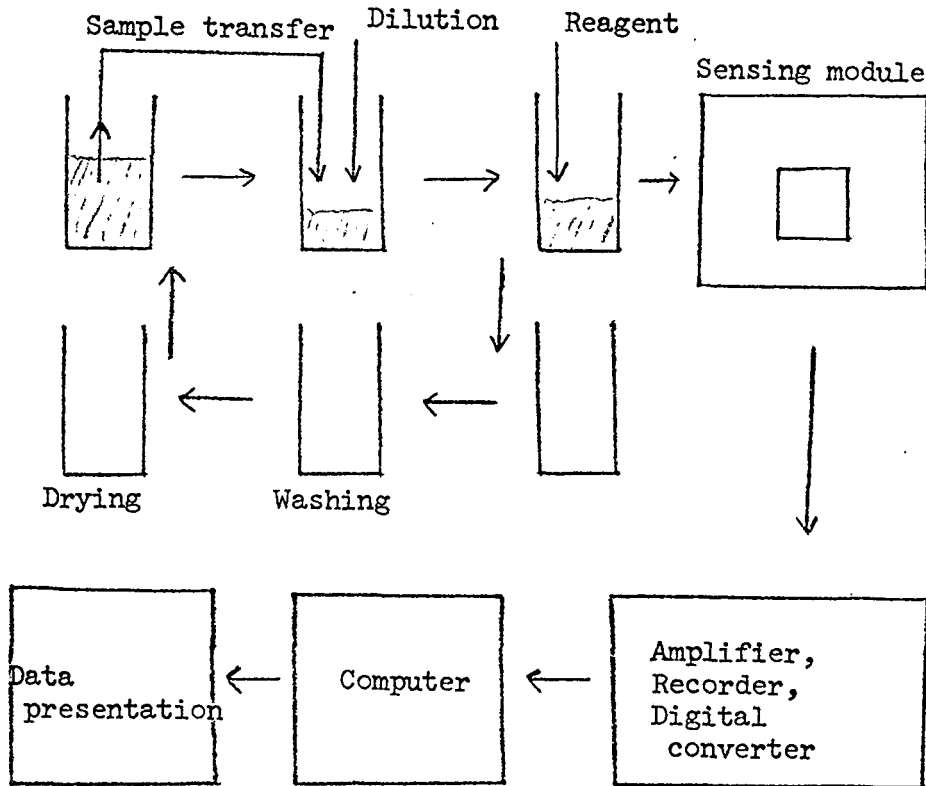

and specific for the test being performed. Any of the above steps can be modified or omitted as requested. The most commonly used methodologies utilize reactions, which can be quantitated by colorimeter, spectrophotometer, fluorometer, flame photometer, atomic absorption, etc.

The signal produced by the photocell or tube is amplified and recorded and/or converted into digital form,

print out and direct readings or in concentration units. The received data can be further processed by computer and presented according to the prepared program.

b. THE ANALYTIC PACKS.

Sample withdrawal, dispensing and dilution is performed by the piston pump. The reagents are proportioned and packed in individual bags for each test. (See Fig. 2.)

FIGURE 2.

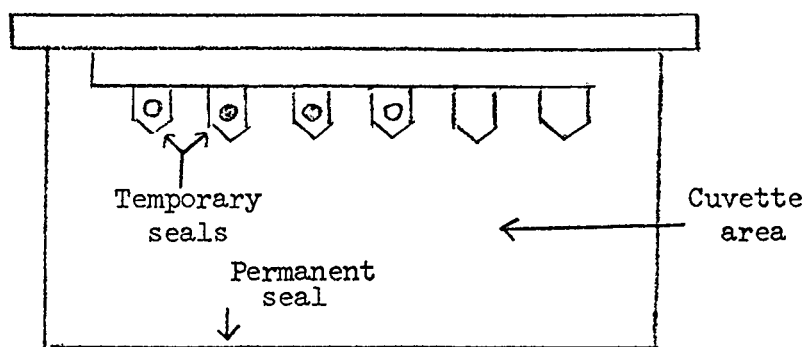
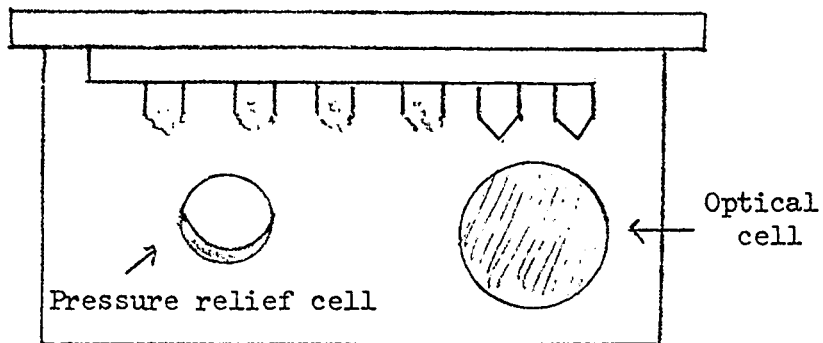

FIGURE 3.



The sample is injected followed by diluent into the bottom of the analytical pack. A conveyor transports the pack to different functional stations. In the breaker-mixer the reagent or reagents (in solution or solid dosages) are released into the lower part of the plastic bag which also serves as a reaction chamber, by opening the proper temporary seals.

At the designated steps (heating, etc.) the pack is retained for a preset time for incubation or color development. The cell-forming dye in the photometer forms a precision cuvette which will be between quartz windows, the excess pack fluid is retained in a pressure relief cell. The output of the phototube is amplified and converted to digital form and presented by a computer. The used pack is discarded. (See Figure 3.)

c. THE CENTRIFUGAL SYSTEMS.

The samples and reagents are pre-loaded on a disc and dispensed by centrifugal force. The samples and reagents are placed in wells concentrically arranged on the distribution disc and positioned in the rotor. (See Figure 4.) With the acceleration the centrifugal force

moves the reagents and the samples into the perimeter of the rotor where they are mixed and transferred through a channel to the cuvettes. The filled rotating cuvettes (See Figure 5) spin past a light beam and are scanned by

FIGURE 4.

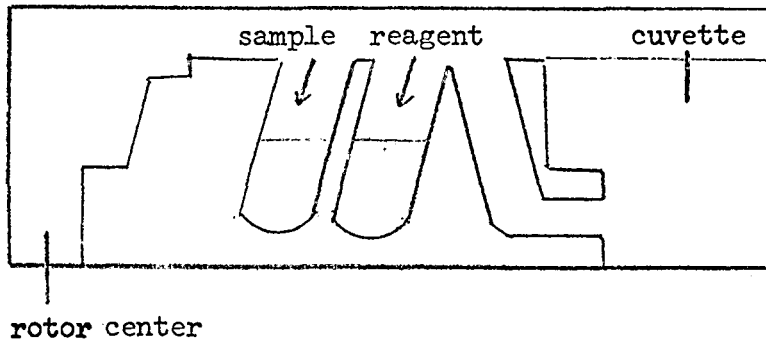
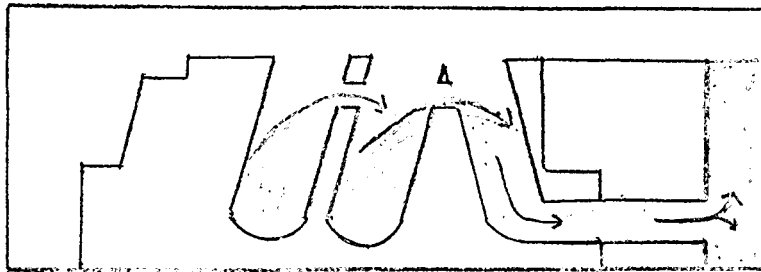

FIGURE 5.



a spectrophotometer and the transmission of the light is measured. The cuvettes, samples and reagent wells can be automatically emptied, rinsed and dried. An oscilloscope pattern displays the readout of each cuvette. The rotor is scanned once in every $1/20$ th of a second. The reading may be converted to a digital form and recorded or processed by a computer.

B. CONTINUOUS FLOW SYSTEM.

Samples and reagents are introduced and proportioned by a peristaltic pump. The aspirated sample is mixed with the reagents and propelled through a flow system where they are mixed and processed according to the methodology. The stream of the reaction product is directed through a sensing device and a continuous recording, storing and presentation of the data is provided. (See Figure 6.)

FIGURE 6.

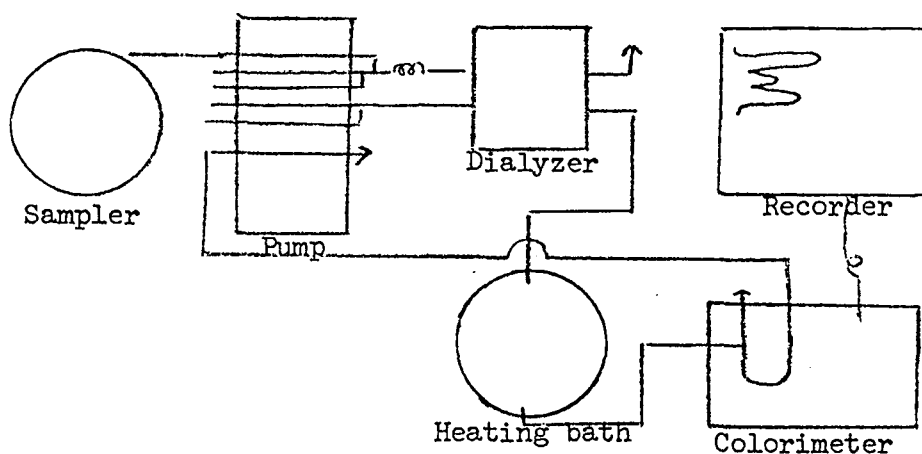

Samples following each other through the tubes and coils are prevented from intermixing by the introduction of air and a wash cycle through the sample tubing between specimens. In addition, the streams are segmented with

air bubbles. This helps to maintain the mechanical integrity of successive samples and improves the wash characteristics of the system by "scrubbing" the walls of the tubings and coils.

A continuous dialyzer removes the blood proteins and the majority of the classical manual procedures can be performed. The necessary heating for color development or incubation is performed on the flowing stream by lead-
int it through a temperature controlled module for the required time. The air bubbles are removed prior to entry into the sensing modules by either decantation or aspiration from a "T" fitting. The presentation of the data is available in chart or digital printout forms.

C. AUTOMATED CLINICAL CHEMISTRY SYSTEMS AVAILABLE COMMERCIALY.

There is a fairly large selection of instruments available with their specific advantages and disadvantages. The choice of equipment depends on the criteria set by the prospective laboratory or institution.

Most of the automated Clinical Chemistry systems available commercially are listed in Table II.

TABLE II

AUTOMATED CLINICAL CHEMISTRY SYSTEMS AVAILABLE COMMERCIALY

Name and Address	Name of System	Theory in Paragraph	# of Available Simultaneous Tests	Approximate Cost \$
AGA Medical Division Lidingoi, Sweden	Autochemist	4.A.a.	24	240,000
1 29 - American Instrument Silver Spring, Maryland	Rotochem	4.A.c.	1	75,000
Bausch and Lomb Analytical Systems Div. Rochester, N.Y. 14602	ZYMAT 340	4.A.a	1	8,765
B. T. L.	Analmatic	4.A.a.	1	----
Beckman Instruments, Inc. Clinical Instruments Operations Fullerton, Calif. 92634	Beckman DSA-560	4.A.a.	2	22,000

B. Brown Melsungen Werk Apparatebau Germany	Systematik	4.A.a.	1	----
Clay Adams Division of Becton, Dickinson & Company Parsippany, N.J. 07054	Blood Chemistry System	4.A.a.	12	29,000
E. I. du Pont de Nemours and Company, Inc. Instrument Products Div. Wilmington, Delaware	ACA	4.A.b.	10	65,000
Electro-Nucleonics, Inc. 368 Passaic Avenue Fairfield, N.J. 07006	GEMSAEC	4.A.c.	1	30,000
Eppendorf Hamburg 63 Postfach 630324	Substratautomat 5030	4.A.a.	1	10-13,000
Griffin-Eel	Bioanalyst	4.A.a.	1	----

HYCEL, Inc. Houston, Texas	HYCEL MARK X	4.A.a.	10	45,000
Joyce, Loebel & Co. Ltd. Great West Rd. Heston Middlesex, England	Mecolab V	4.A.a.	4	13,000
LKB Producter AB S-161 25 Bromma 1 Sweden	LKB 8600	4.A.a.	1	9,500
Perkin-Elmer Corp. Norwalk, Connecticut	C4 Automatic Analyzer	4.A.a.	4	25,500
Philips Electronic Instruments 750 South Fulton Avenue Mt. Vernon, N.Y. 10550	Norelco Unicam	4.A.a.	1	7,200
Poli-Max 00197 Roma Viole Parioli 101/6	Clino-Mak	4.A.a.	1	5,000
Quickfit & Quartz 6200 Wiesbaden Schierstein, Germany	Chemical Analyzer 617	4.A.a.		----

Technicon Corporation Tarrytown, N.Y. 10591	Auto Analyzer	4.B.	1-12	6-64,000
Union Carbide Corp. Biomedical Products Tarrytown, N.Y. 10591	CentrifiChem	4.A.c.	1	21,500
Vickers Limited Medical Engineering Basingstoke, Hampshire, V. K.	Vickers Multi- channel 300	4.A.a.	2-20	23-242,000
Werner-Chilcott Labs. Instrument Division Richmond, California	Robot Chemist	4.A.a.	1	----

Table II requires some explanation. Its presentation helps the prospective buyer to find out where to obtain the necessary detailed information.

The number of available simultaneous tests (channels) means, how many different types of determinations can be performed on the same sample at the same time. This expression would be less misleading by stating, the number of channels available, because the Union Carbide CentrifChem is able to perform 30 tests simultaneously in 3-5 minutes, but only one determination at a time, therefore, it is considered only one "channel."

The price of the systems reflects the following:

The sophistication and the flexibility of the hardware. They may include some data-handling devices, such as digital printout or dedicated computer systems. The speed (number of tests/hour). Some prices include different sensing devices, colorimetric, fluorometric, flame, etc.; others list those as optional.

Multichannel systems are not simply the addition of several single channels. With the coordination of stream or specimen splitting and also the recording and data handling it provides significant savings in efficiency and labor. 3-4 technicians are needed to operate six single

channels, while the same workload can be handled easily by one person on a 6 Channel system.

After considering the above listed and some additional factors the decision is still a calculated risk. In spite of the claim of several manufacturers that they have the answers to all of our problems, the best we can come up with is an intelligent compromise.

5. THE NECESSARY AND DESIRABLE TRENDS IN AUTOMATED CLINICAL CHEMISTRY.

With the introduction of these analytical systems, most of the old manual tests were or can be automated. In this "chain reaction" the instrumentation presently overtook the lead; the tests remained unchanged. More specific tests will have to be worked out for diagnosis. The Oak Ridge National Laboratory have developed a high resolution analytical system capable of identifying 150 regularly appearing components in urine. Only 30 such components can be identified by conventional tests currently used⁹.

Predictive and preventive medicine are the future trends in medical practice. Clinical Chemistry could become a powerful tool in detecting unsuspected diseases in the pre-clinical state. The so-called "new admission screening," using a multi-channel systems, is already an important development in this direction. The limitation of this method is the insensitivity of the commonly used biochemical parameters. In conventional Clinical Chemistry, we usually determine the concentration of metabolic end-products in the blood or other body fluids,

without concern with how the end-product concentration is maintained. Our vast knowledge of alternative pathways of intermediary metabolism is seldom utilized for diagnostic purposes.

Our working hypothesis is that the understanding of the mechanism by which the concentration of metabolic end-products are maintained, instead of the mere measurement of the concentration of these end-products, reveals abnormalities before the end-product concentrations themselves become abnormal. If future research proves this hypothesis, the following points must be considered:

- A. Screening procedures will have to be aimed at the clinically normal population instead of the patient population.
- B. New technology must be developed to handle the rather complicated problems of metabolic studies.

We reported some initial results concerning the above hypothesis¹⁰.

To illustrate the above hypothesis let us consider the question of the maintenance of normoglycemia in liver cirrhosis. Normal levels of blood glucose are generally maintained through dietary intake, degradation of glycogen depot of the liver, or by gluconeogenesis. In damaged

liver, where glucose uptake is decreased and the glycogen depot is depleted, gluconeogenesis is probably the most important mechanism to maintain normal blood sugar levels. A simplified scheme of gluconeogenesis is shown in Figure 7. Amino acids, lactate, pyruvate and glycerol are the most common precursors. The amino acids enter the reversed glycolysis through transaminase, lactate and pyruvate through the dicarboxylic acid shuttle, and glycerol through triosephosphate isomerase.

We measured the incorporation of C-14 labeled pyruvate and glycerol into blood glucose in different stages of liver cirrhosis in rats. Cirrhosis of the liver was produced by the administration of CCl_4 . CCl_4 -induced changes in the liver are reversible after 60 days, but become irreversible after 140 days of treatment. Treatment longer than 140 days results in increased mortality. This experimental model afforded us the opportunity to examine the efficiency of gluconeogenesis during reversible, irreversible and terminal stages of cirrhosis.

The experimental data are consistent with the hypothesis that gluconeogenesis is an important factor in the maintenance of normoglycemia during liver diseases, and that the failure of this mechanism to function during the

FIGURE 7.

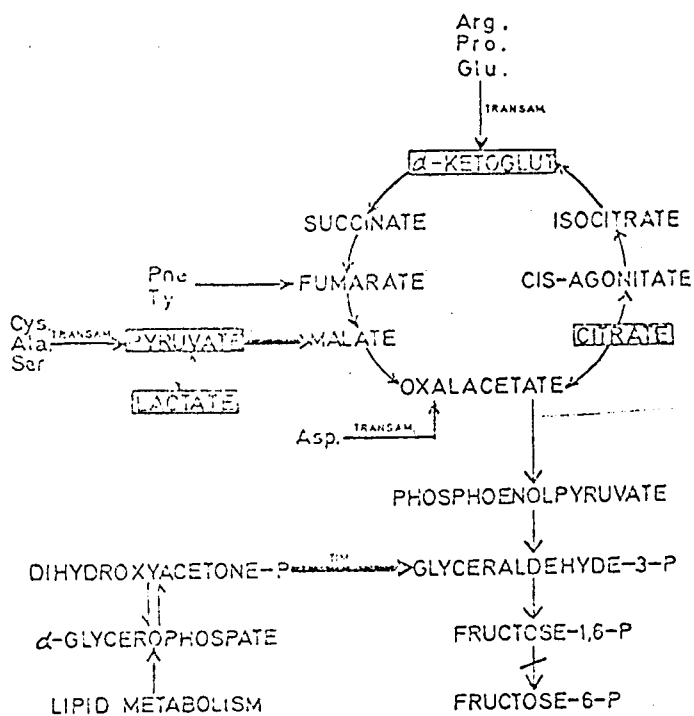

terminal stages may be the cause of hypoglycemia.

We suggest that the above data can be used to diagnose the transition from reversible to irreversible, and to the terminal phase of cirrhosis. This example illustrates how metabolic studies may provide more information sooner than the simple measurement of the concentration of the end-product, in this example glucose, in the blood.

Although completely automated systems do not exist, several steps are solved or being worked on that the day may come for anyone, as Gambino predicts¹¹, to go to a self-service center, perform some functional tests, stick his finger in a small hole and have a few drops of blood taken, have all the information compared with all previous data through the use of a massive memory bank and be told by the computer to promote the necessary action without creating fear.

With the multiphasic screening programs, it will be possible to detect diseases in people who appear to be well but in fact suffering from diseases and they can be treated adequately, before it secures a firm hold. Such comprehensive examinations are conducted by the Permeante Medical Group¹², are beginning to prove their necessity.

But more satisfactory forms of health oriented instrumentation, automation, computation, communication, systems engineering, and operations research techniques must be developed.

It is feasible that with all the available information on metabolic or biochemical aberrations, etc., a computer system will discover predictive patterns of ill health or approaching diseases, providing ample time for prevention, increasing the average span of life, a healthier life.

II. AN AUTOMATED FLUOROMETRIC METHOD FOR DETERMINATION OF α -HYDROXYBUTYRIC DEHYDROGENASE.

1. INTRODUCTION.

Rosalki and Wilkinson described that there exists an enzyme in serum other than Lactic Dehydrogenase (LDH) capable of reducing α -ketobutyrate¹⁴.

They measured dehydrogenase activities spectrophotometrically at 340 m μ in 0.067 M Sorensen phosphate buffer at pH 7.4. The ratio of the activities against pyruvate and α -ketobutyrate was found to vary between 1.4:1 and 1.1:1, are outside the limits of any possible experimental error.

The spectrophotometric method of Wroblewski and LaDue¹⁵ for LDH determination describes the same buffer; 0.23×10^{-5} M pyruvate substrate and 3.8×10^{-7} M NADH₂ concentrations in the final volume of the reaction mixture. This was modified so that α -ketobutyrate replaced pyruvate.

Experimental results have shown¹⁶ that this enzyme, α -Hydroxybutyric Dehydrogenase (HBDH) has some tissue specificity. In heart tissue extract they found about

twice as much activity as in liver tissue extracts. On the other hand, the ratio of LDH activities of heart and liver tissues are about reversed.

HBDH has increased activity in myocardial infarction but in liver disease, variable results were obtained. If this test is performed in conjunction with LDH, there seems to be a tissue specific ratio of LDH/HBDH that is useful in differential diagnosis of heart and liver diseases.

Although some authors^{17,18.} believe HBDH is identical with one of the LDH isoenzymes, several reports recommended this determination. Preston, et. al.^{19.} reported the results of a year's study on 409 patients. They question the organ specificity and do not believe that it is the "ideal" test for myocardial infarction. On the other hand they state, that "false-negative" results are unusual. If we look at the time sequence of the generally performed diagnostic enzyme tests, the SGOT elevation is rather short after the infarct, not more than 4-5 days, LDH is elevated for a longer period of time, but HBDH elevation may last as long as 2-3 weeks. CPK is more specific and gives an early indication of the infarct, however, this determination is rather time con-

suming and its value affected also by physical activity and renal disease. Kounttinen and Halonen^{20.} confirmed the above observation. Rosalki^{21.} worked out an accurate and simple colorimetric method for the determination of HBDH and further work by Elliot, et. al.^{22.}, Rosalki and Wilkinson^{23.}, also by Stuart, et. al.^{24.}, proves the usefulness of this determination.

2. EXISTING METHODS.

A. MANUAL.

a. COLORIMETRIC.

Rosalki^{21.} utilizes the forward reaction of

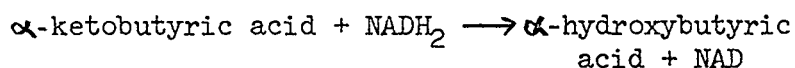

The reaction is stopped by the addition of 2-4 dinitrophenylhydrazine which reacts with the remaining α -ketobutyric acid to form α -ketobutyric acid-hydrazone. On the addition of alkali, a brown color is produced and the color intensity is in proportion with the unreduced α -ketobutyric acid and inversely indicates the HBDH

level. The buffer is the Sorensen phosphate M/15 at pH 7.4, the substrate is approximately 0.001 M α -ketobutyric acid. 10 mg of NADH, sodium salt is dissolved per ml of phosphate buffer. 0.4 N sodium hydroxide is used to stop the incubation.

The optical densities are observed at 490 m μ .

b. SPECTROPHOTOMETRIC.

Both the forward α -ketobutyric acid + NADH and the reversed α -hydroxybutyric acid + NAD reactions were studied by Plummer and Wilkinson²⁵. The forward reaction is utilized in all publications. 0.067 M Sorensen phosphate buffer, pH 7.4 containing 0.35 μ mole NADH₂ and 3.3 mM sodium 2-oxobutyrate in a final volume of 3 ml is the reaction mixture. Some commercially available kits (Calbiochem calsubs, Sigma 20-UV reagents) refer to the above procedure.

c. FLUOROMETRIC.

Elevitch and Phillips reported²⁶ a kinetic fluorometric assay for the measurement of LDH activity. The

same principle was adapted by Benson and Benedict²⁷.

Using the forward reaction, as the α -ketobutyric acid is converted to α -hydroxybutyric acid, the fluorescence of the NADH_2 is proportionally diminished. The decrease in fluorescence is plotted as a negative slope on a linear recorder. The reagents used are from the Sigma spectrophotometric kit. Instrument is the Turner fluorometer, model 111. Slit width IX. Primary filter 760. Secondary filters 2A and 48.

The enzyme activity is determined by the measurement of the recorded change in fluorescence as reduced nicotinamide adenine dinucleotide (NADH_2) is oxidized (NAD) during the first minute of the reaction.

B. AUTOMATED.

a. ANALYTIC PACK.

This system measured the reversed α -hydroxybutyrate to α -ketobutyrate reaction coupled to an oxidation-reduction indicator reaction.

The NADH_2 reduces the blue dye, 2,6-dichlorophenolindophenol (DIP) to its colorless form in the presence

of phenazin methosulfate (PMS). The rate of decrease in absorbance at 600 m μ is directly proportional to the HBDH activity.

b. CENTRIFUGAL SYSTEM.

α -ketobutyric acid is reduced to α -hydroxybutyric acid in the presence of HBDH and NADH₂. The NADH₂ is oxidized to NAD. The rate of reaction is followed by observing the decrease in absorbance at 340 m μ .

c. CONTINUOUS FLOW SYSTEM.

Dube, et. al.²⁸ described an automated spectrophotometric procedure. They measured the decrease in absorbance of the NADH₂ at 340 m μ after the enzymatic oxidation using 0.29 M solution of α -ketobutyric acid as substrate. The flow diagram is shown in Figure 8.

The rate of sampling is 40/hour. The readings were performed on a Beckman DB spectrophotometer.

FIGURE 8.

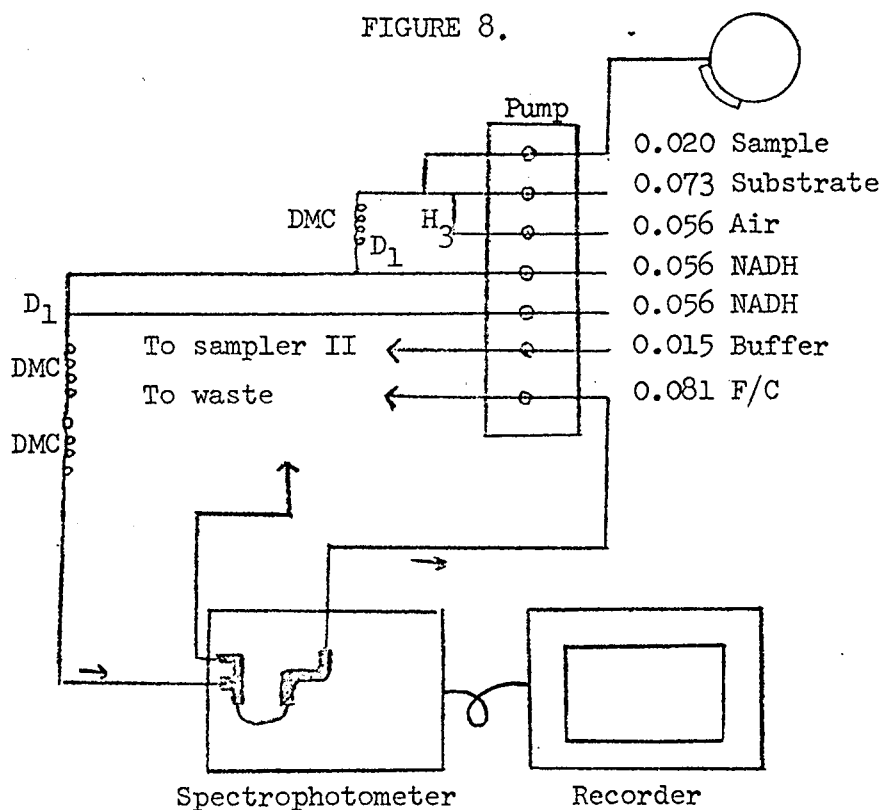

C. ADVANTAGES OF THE FLUOROMETRIC MEASUREMENTS.

a. Lowry, et. al.^{29.} and Greengard^{30.} pointed out that one of the greatest achievement of fluorometry in assaying the pyridine nucleotides is the 10 to 100-fold increase in sensitivity. The possibility of decreasing the required amount of sample becomes a deciding factor.

b. The increased linearity^{31.} extends the measurable range of activities, eliminating some repetition of tests in dilutions.

c. Serum turbidity has little or no effect because of the small amount of sample used. Light scattering, inner filter effects and quenching are also minimized.

d. The native fluorescence of NADH has a better index of its chemical structure and biological activity than its absorption of light at $340 \text{ m}\mu^{30}$.

3. PROPOSED METHOD.

A. SELECTION OF A NEW METHOD.

Development of new methods in Clinical Chemistry are initiated by: a. The discovery of a new substance with diagnostic importance, b. Utilization of a new chemical reaction for the identification or quantitation of the constituents, c. The introduction of some new or improved instrumentation or automation.

In the case of HBDH all these steps were followed. The advantages of automation versus manual procedures and the fluorometry versus colorimetry and spectrophotometry were described in previous chapters.

The choice of instrumentation was predetermined by

our existing methodologies. We perform routine enzyme assays (SGOT, SGPT, LDH) by the fluorometric continuous flow system, so all the necessary equipment was available. The same principle can be applied to any other automated systems (discrete sampling), if a fluorometric sensing module is available.

B. PRINCIPLE.

This method is the fluorometric adaptation of the Dube, et. al.²⁸ spectrophotometric determination. The reaction (Figure 9.) was automated and studied in both

FIGURE 9.

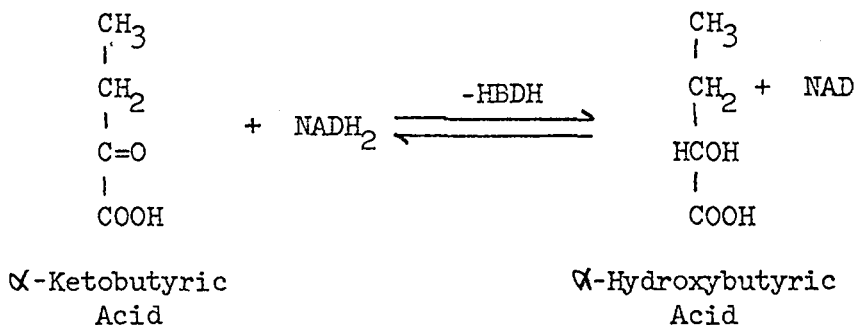

directions. Benson, et. al. recommended the forward reaction, because of the lack of available hydroxy substrate and stating that the NAD required for the reverse reaction is less stable than the NADH³².

We found well-controlled substrate available and the NAD as quite stable in dry powder form when refrigerated.

Experimental results indicated that the reversed hydroxy-keto reaction was better suited for continuous flow analysis.

C. EQUIPMENT.

Semi-automated method was described by Henry, et. al.³³ and a basic design for automated enzymes assays involved $\text{NAD} \rightleftharpoons \text{NADH}$ reaction was suggested by Schwartz, etl. al.³⁴. A fluorometric procedure for LDH described by Brooks and Olken³⁵ is similarly arranged that the one was assembled in our laboratory.

Auto-analyzer modules of sampler II, proportioning pump, controlled temperature heating bath, fluorometer and chart recorder were used in the assembly of flow diagram as shown in Figure 10.

D. REAGENTS.

a. BUFFER. Dissolve 121 gm of Tris (hydroxymethyl)-amino methane in approximately 800 ml distilled water.

FIGURE 10.

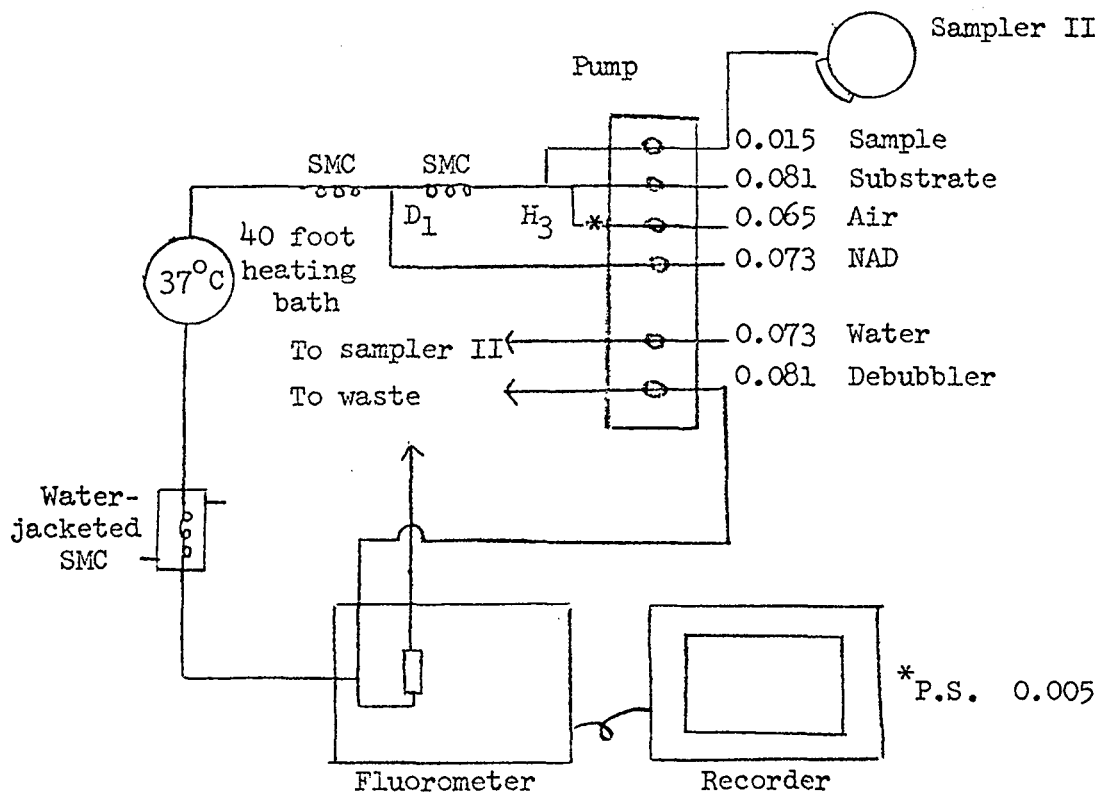

- Adjust the pH at 25°C to 7.6 with concentrated HCl and add water to a final volume of 1 liter. A working solution of 50 mM is obtained by 1:20 dilution of the stock buffer with distilled water. The buffer is stable for at least one year.

b. NAD. Pre-weighed portions of NAD are stored in refrigerator in screw-capped vials. Just before use, the content of a vial (100 mg) is dissolved in 58 ml of working buffer to obtain a concentration of 5.25 mM.

c. HBDH SUBSTRATE. 0.1 M DL- α -Hydroxybutyric Acid, sodium salt. Dissolve 12.6 g in 100 ml of working Tris buffer. The substrate is stable for one month if refrigerated. Before use, add 0.5 ml of Brij per liter as a wetting agent.

d. STANDARDS. Stock solution, NADH 10 μ moles/ml. 76.3 mg of NADH disodium salt are dissolved in about 8 ml of working Tris buffer and adjusted to a final volume of 10 ml. Prepare daily before use. Serial dilutions for 0.25-5 μ moles/ml are made up with the working buffer.

E. PROCEDURE.

Standards and serum samples are aspirated at the rate of 40/hour. The samples are diluted with HBDH substrate in Tris buffer and segmented with air, mixed in the first mixing coil. Then NAD in Tris buffer is added and mixed.

The reaction mixture is incubated in a 40 foot coil at 37^o C. After incubation the stream passes through a water-jacketed mixing coil, the air segments are removed and the reaction mixture is pumped through the flow cell of the fluorometer. The fluorometer is equipped with a 7-60 primary and 2A plus 48 secondary filters. Aperture and full scale controls are adjusted so that the reagent base line will read about 5% on the chart paper (minimum fluorescence), aspirating the maximum standard, a reading of 80-90% should be obtained. At a repeated aspiration of water through the sample line, the recorder pen should return to the reagent base line and the system is ready for operation.

F. STANDARDIZATION.

The enzyme activity expressed as micromoles of NADH formed at the given experimental conditions. To obtain the final concentration of NADH in the reaction mixture a dilution factor is needed.

$$F = \frac{F_s}{\sum F_r}$$

Where F_s = flow rate of the standard, the sum of F_r = flow rate of all the reagents. The manifold described delivers 0.1 ml/minute sample, 2.0 ml/minute NAD and 2.5 ml/minute substrate.

An alternate standardization can be obtained by using dilutions of commercially lyophilized serum as secondary standards. This can be assayed by the selected reference methods and has the advantage of using conventional units given in the literature.

After performing the preliminary work with primary standards, we continuously performed the standardization by the alternate method. A typical calibration curve is shown on Figure 11.

FIGURE 11.

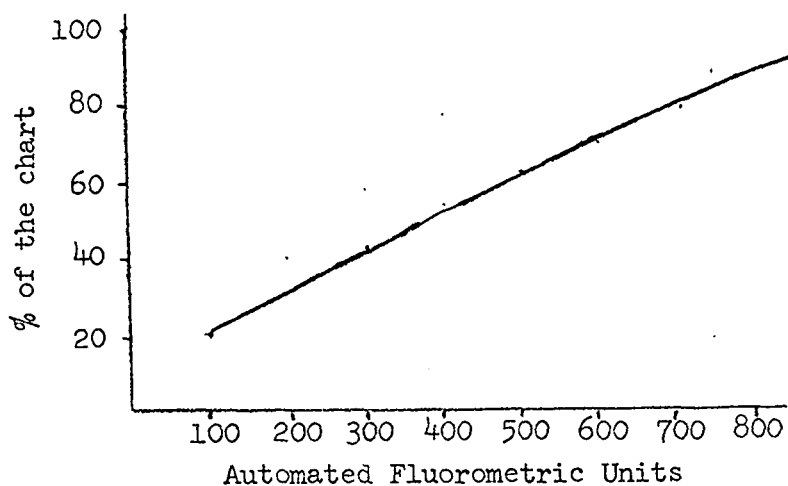

G. THE EFFECT OF THE DIFFERENT VARIABLES.

a. TEMPERATURE.

With increasing incubation temperatures, as it was expected, the activity increases. There is a counter acting factor, the negative temperature coefficient of fluorescence of NADH. This can be eliminated by a water-jacketed cooling coil inserted before the fluorometer. 37°C was chosen because it is easily maintainable even in the warmest summer days and the denaturization³⁶ does not reach a point of significance.

b. pH.

Different pH adjustments of the buffer were made and optimum values were obtained between 7.2 and 7.8.

c. SUBSTRATE.

Variable concentration of DL- α -hydroxybutyric acid solutions were tested and found to have very little influence on the HBDH activity. (See Figure 12.)

FIGURE 12.

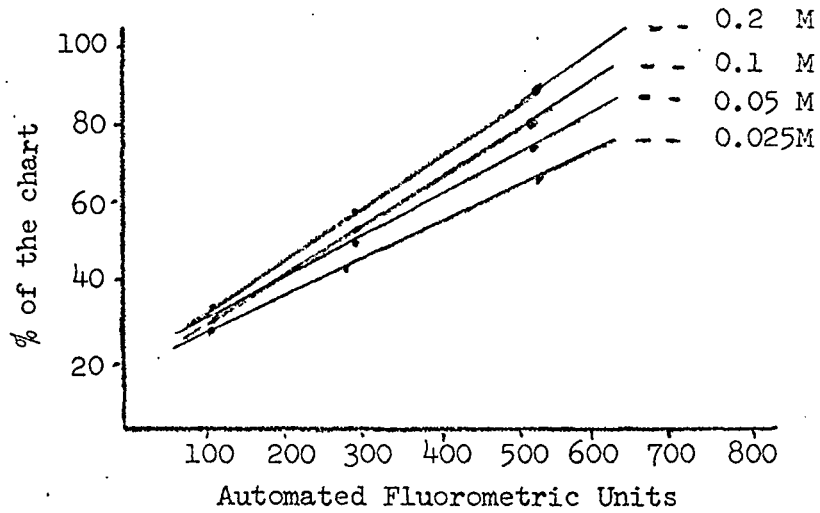

H. REPRODUCIBILITY.

A typical run of the standards and replicate specimens are shown on Figure 13.

The day to day reproducibility was tested on lyophilized pooled serum for a period of three months and the values are given in Table III.

I. RECOVERY.

Known amounts of serum with assayed values are added

FIGURE 13.

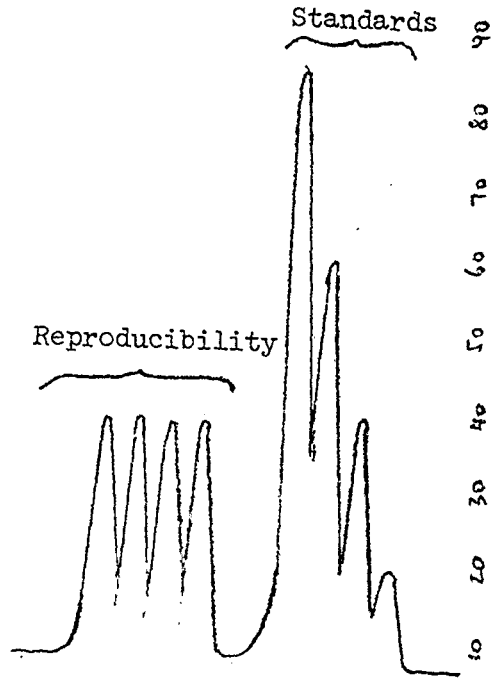

TABLE III

Day	Units
1	123
2	120
3	122
4	118
5	121
.	
.	
.	
.	
.	
.	
64	125

Average = 123

Standard deviation = 2.11

to previously assayed samples. The recovery results are shown in Table IV.

TABLE IV

Sample	Result	After addition		Difference	Recovery
		Result	Theoretical		
1	126	210	206	+4	101.9%
2	240	328	320	+8	102.5
3	110	295	290	+5	101.7
4	80	165	160	+5	103.1
5	318	487	478	+9	102.0
6	470	643	630	+13	102.0
7	130	296	290	+6	102.0
8	105	272	265	+7	102.6
Average recovery					102.2%

J. SERUM BLANK.

Standards and samples were processed similarly as during the determinations but DL- α -hydroxybutyric acid substrate was substituted with Tris buffer.

The recorded peaks representing the fluorescence of the blanks were less than 3% of the chart and their influence on the assay results are so negligible that running blanks may be simply omitted.

K. MAINTENANCE, TROUBLESHOOTING.

The modules have to be maintained according to the manufacturer's specifications. Special attention should be given to the protein build up in the tubing, coils and flowcell. This can be eliminated or greatly reduced by placing the sample and reagent lines in about 10% sulfuric acid for 10 minutes before every run, followed by pumping distilled water for about 15 minutes. The life expectancy of the tubes is about 160 working hours, but periodic inspection of the tubes for wear is recommended and all tubes should be replaced in every 4-6 weeks. Coils, fittings and flowcell should be thoroughly cleaned every month.

After every 10th specimen a cup of distilled water and a cup of standard should be inserted to recheck the reagent base line and the reproducibility.

All refrigerated reagents should be brought to room temperature before use.

Serum specimens should be centrifuged properly and rechecked for possible secondary clots, because the most frequently occurring trouble is the clogging of the probe, sample line or H₃ fitting.

L. COMPARISON OF METHODS.

Several standards and samples were assayed by the manual spectrophotometric method of Elliot and Wilkinson³. General good agreements were obtained as far as normal or elevated results are concerned. No linear agreement was possible because of the different experimental conditions. Correlation of results expressed in international units is impossible, by the very poor definition of international units. Amador, et. al.³⁷. stated that comparison of forward and reverse methodologies are practically impossible. Weinberg and Adler³⁸. tried unsuccessfully to find any mathematical correlation that would enable them to compare two methods with different kinetics. Until and if completely acceptable uniformed experimental conditions will be observed by all investigators, the use of an author's name is the simplest way to define units and it should be used only for that particular assay. No numerical comparison of those units should be forced because only comparison of ranges and multiples of normal ranges are valid.

4. CLINICAL EVALUATION.

Our laboratory performed HBDH determinations on 84 healthy blood donors. The normal range for this group was found to be 60-170 units with average of 95 and the standard deviation of ± 7.63 .

Consequently we performed 970 HBDH determinations on patients whose serum was submitted for LDH determinations. 512 of these showed elevated LDH activities and 714 patients had abnormal HBDH results. 92 patient histories were reviewed and during the following months 27 autopsy reports of those patients with elevated HBDH results became available.

In agreement with Dube, et. al.²⁸, we found that the proposed LDH/HBDH ratio not as clear cut as suggested by Elliot and Wilkinson⁵ and cannot be used for differential diagnosis.

But I would not belittle the importance of this test as Amador and Wacker³⁹ do, because even if there are simple ways to differentiate clinically an acute myocardial infarction from liver disease and HBDH may not be the test for it, its high concentration in tissues of liver, heart, kidney, muscle, lung and blood cells provides sensitivity

in the detection of diseases of most organ systems.

5. SUMMARY.

An automated fluorometric procedure for the determination of α -Hydroxybutyric Dehydrogenase (BHDH) is presented. The increased activity of this enzyme is a very sensitive indicator of tissue damage of most organs. Performed as a screening test it may promote the necessary action toward differential diagnosis and treatment.

REFERENCES

1. Skeggs, L. T. Jr. Am. J. Clin. Pathol. 28, 311 (1957).
2. Kinney, T. P. D. and Melville, R. S. Lab. Invest. 16, 803 (1967).
3. Anderson, N. G. FASEB Annual Meeting Apr. 16, 1969.
4. Nelson, M. G. J. Clin. Path. 22, 1 (1969).
5. Klein, B. Med. Lab. August, 1968, p. 18.
6. Skeggs, L. T. Jr. and Hochstrasser, H. Clin. Chem. 10, 918 (1964).
7. Thiers, R. A., Bryan, J. and Oglesby, K. Clin. Chem. 12, 120 (1966).
8. Bryan, D. J., Wearne, J. L., Viau, A., Musser, A. W., Schoonmaker, F. W. and Thiers, R. E. Clin. Chem. 12, 137 (1966).
9. Brown, J. H. U. and Melville, R. S. Lab. Management, June, 1969.
10. Hutterer, F., Sarkozi, L. and Roboz, J. Clin. Chem. In press, (1970).
11. Gambino, R. S. Adv. in Automated Anal. 3, XIII (1969).
12. Collen, M. F. J. Amer. Med. Ass. 198, 830 (1966).
13. Brown, J. H. U. and Dickson, J. F. III. Science 166, 334 (1969).
14. Rosalki, S. B. and Wilkinson, J. H. Nature 188, 1110 (1960).
15. Wroblewsky, F. and La Due, J. S. Proc. Soc. Exp. Biol. 90, 210 (1955).
16. Elliot, B. A. and Wilkinson, J. H. The Lancet 1, 698 (1961).

17. Pigliaro, L. P. and Notarbartolo, A. The Lancet 1, 1043 (1962).
18. Elliot, B. A. and Wilkinson, J. H. The Lancet 2, 71 (1962).
19. Preston, J. A., Batsakis, J. G. and Briere, R. O. Amer. J. Clin. Path. 41, 237 (1964).
20. Kounttinen, A. and Halonen, P. I. Amer. J. Cardiology, 10, 525 (1962).
21. Rosalki, S. B. J. Clin. Path. 15, 566 (1962).
22. Elliot, B. A., Jepson, E. M. and Wilkinson, J. H. Clin. Sc. 23, 305 (1962).
23. Rosalki, S. B. and Wilkinson, J. A. J. A. M. A. 189, 61 (1964).
24. Stuart, J., Crawford, I. C. and Forshall, J. Brit. M. J. 5432, 423 (1965).
25. Plummer, D. T. and Wilkinson, J. H. Biochem. J. 87, 423 (1963).
26. Elevitch, F. R. and Phillips, R. E. Progress in Clin. Path. Vol. I. Grune and Stratton, Inc., N. Y.
27. Benson, P. A. and Benedict, W. H. Tech. Bull. of Reg. Med. Tech. 36, 106 (1966).
28. Dube, V., Hunter, D. T. and Knight, J. A. Amer. J. Clin. Path. 50, 491 (1968).
29. Lowry, O. H., Roberts, N. R. and Kappahn, J. I. J. Biol. Chem. 222, 1047 (1957).
30. Greengard, P. Photoelectric Spectr. Group Bull., 11, 292 (1958).

31. Udenfriend, S. Academic Press, N. Y. 1962, p. 316.
32. Kaplan, N. O., Colowick, S. P. and Barnes, C. C. J. Biol. Chem. 191, 461 (1951).
33. Henry, J. B., Cestacic, E. S. and Goodwin, A. Am. J. Clin. Path. 40, 252 (1963).
34. Schwartz, M. K., Kessler, G. and Bodansky, O. J. Biol. Chem. 236, 1207 (1961).
35. Brooks, L. and Olken, H. G. Clin. Chem. 11, 748 (1965).
36. Hess, B. and Henley, K. S. Academic Press, N. Y. 1963, p. 140.
37. Amador, E., Dorfman, L. E. and Wacker, W. E. C. Clin. Chem. 9, 891 (1963).
38. Weinberg, M. S. and Adler, D. H. Clin. Chem. 10, 749 (1964).
39. Amador, E. and Wacker, W. E. C. Methods of Biochem. Analysis 13, 265 (1965).