

# Analysis of Power Quality Problems on Nigerian 330 kV Power System Using Statcom with Voltage Sensitivity Index

Balogun Abass

National Centre for Hydropower Research and Development, University of Ilorin P.M.B, 1515, Kwara State, Nigeria

Corresponding Email: [getwalbass@yahoo.co.uk](mailto:getwalbass@yahoo.co.uk)

## Abstract

Transmission system is the transportation of electrical energy from generating stations to load centers. However, increase usage of non-linear loads from the consumers has led to electrical Power Quality (PQ) problems which have negative impacts on the operation of the power system especially Nigerian power system. This research analyzed the PQ problem on Nigerian 330 kV power system. Newton-Raphson (NR) iterative method was used to performed load flow analysis on Nigerian 28-bus transmission systems. Then power injection model of the Static Synchronous Compensator (STATCOM) was incorporated to modify the NR mathematical model. The suitable placement for the STATCOM in the system was determined using Voltage Sensitivity Index (VSI) and simulation was done in MATLAB/SIMULINK. The results showed that, the suitable placements of STATCOM controller in the power system were buses 5, 8, 12 and 16. The corresponding STATCOM reactive power, sag voltage and sag duration for buses 5, 8, 12 and 16 were 72.56 MVar, 0.77454 p.u, 0.7336s; 65.35 Mvar, 0.7464 p.u, 0.7419 s; 50.86 Mvar, 0.7615 p.u, 0.6512 s and 53.75 MVar, 0.7442 p.u, 0.5972 s, respectively. Therefore, the results have established the importance of STATCOM with VSI in obtaining suitable solution for PQ problems on electrical power system.

**Keywords:** Transmission System, Electrical Energy, Non-linear Load, Power Quality, Newton-Raphson, STATCOM, Voltage Stability Index.

**DOI:** 10.7176/ISDE/12-6-03

**Publication date:** October 31<sup>st</sup> 2022

## I. INTRODUCTION

A Power Quality (PQ) issue is one of the extremely serious problems in power system due to its dangerous impact on electricity suppliers and the consumers [1]. This concept (PQ) is defined as the capability of the electricity grid to provide customers with reliable, ideal and non-tolerant electricity. In a power system, faults, dynamic operations, or nonlinear loads often cause various types of PQ problems such as voltage sags, voltage swells, switching transients, impulses, notches and flickers, harmonics, such [2]. In addition, the increased use of sensitive electronic circuitry by industrial and residential customer, as well as the progress of utility deregulation and competition has imposed greater demand on the quality of power [3, 4]. Thus, PQ has become the term used to describe a wide range of electrical power measurement and operational issues [2].

However, in order to mitigate the PQ problems in power system, Flexible Alternating Current Transmission Systems (FACTS) devices have been widely recognized as powerful tools in providing a veritable way to reduce the excess voltage or current to avoid damage to the power system [5]. The FACTS devices are emerging technologies for providing reactive power compensation to mitigate issues of PQ by improving the system stability and control voltage on power system [6-8].

Different FACTS devices such as Static VAR Compensators (SVC), Static Synchronous Compensators (STATCOM) and Synchronous Condensers (SC) have been reported for the effective mitigation of PQ problem but compensation capability of STATCOM is better [9]. The STATCOM, being one of the most important members of shunt-connected FACTS devices, is more often used to enhance the PQ performance of transmission system operation because that its compensating current is independent of network voltage level of the transmission at the point of connection such that the injected current is virtually in quadrature with the line voltage [7, 8, 10-12]

However, this technique is not efficient enough for PQ problem mitigation because it cannot provide optimum solution for PQ problems. Therefore, the need for a suitable and effective mitigation technique to reduce the PQ problems based on voltage sag in power system in order to provide better uninterrupted PQ and high-quality power with minimal voltage variations. This work therefore, incorporate STATCOM power injection model on Nigerian 330 kV, 28-bus transmission system as compensator device so as to increase the capability of the system from disturbances. In order to find the best placement and exact size of the STATCOM controller in the system, Voltage Sensitivity Index (VSI) was employed. This expected to provide adequate reactive power control in mitigating PQ problems. Also, this will help both the utilities and the consumers to have uninterrupted reliable power supply resulting in generation of profit for their businesses and overall satisfaction of the customers.

## II. Nigeria Transmission System

Electrical transmission line is designed to convey electrical power from the power source over a long distance with minimum losses and with high-voltage three-phase Alternating Current (AC) [13]. Transmission line voltages are usually considered to be 110 kV and above. Lower voltages, such as 66 kV and 33 kV, are usually considered sub-transmission voltages, but are occasionally used on long lines with light loads [7, 14, 15].

The transmission capacity of the Nigerian electricity transmission system is made up of about 5,523.8 km of 330 kV transmission lines and 6,801.49 km of 132 kV transmission lines 23km of 330/132 kV sub-stations and 91 km of 132/33 kV substations. The transmission lines are in radial and are overloaded [15-16]. In addition, there are currently 77 grid-connected generating plants in operation in the Nigerian Electricity Supply Industry (NESI) with a total installed capacity of 12, 800 MW and available capacity of 7,139.6 MW [16]. However, the average power generated fluctuates between 1,500 MW and 5,000 MW which is inadequate when compared to the 10,000 MW of energy demanded by the millions of consumers craving for electrical energy. Also, only nineteen out of the seventy-seven installed generating units were in operation, thereby resulting in recurrent power outages across the nation [17].

Furthermore, Nigeria transmission system is characterized with very lengthy transmission lines and feeders which make voltage control difficult. Also, the transmission system is characterized by poor voltage profile, inadequate dispatch and control infrastructure, radial and fragile grid network, frequent system collapse, exceedingly high transmission losses. The network is highly stressed and weak, this makes it prone to voltage instability [18, 19].

This has reduce the maximum power transfer capability on the lines thereby reducing the margin between the planned power transfer and the maximum limit at which the lines is susceptible to transient and dynamic instability thus vulnerable to Power Quality (PQ) disturbances [18]. In other to avoid these PQ disturbances, there is a need to carry out thorough maintenance at least once every forty-one days along the transmission line [13, 16, 18, 20]. Therefore, it is very essential to study the effect of PQ disturbance on the Nigeria power transmission system in order to avoid any system collapse and then proffer focused solutions to reduce the disturbance on the system.

Figure 1 shows the single-line diagram of the Nigerian 330 kV, 28-bus transmission system proposed as a case study for this research. The network has 60 transmission line circuits, 8 effective generation stations, 20 load stations and 52 transmission lines. The entire grid system is sectioned into North, South-East and the South-West geographical zones. The North linked the South via one-triple circuit lines between Jebba and Oshogbo, the west connects the East with the help of one transmission line originating from Oshogbo to Benin and one double line from Ikeja to Benin [7, 13].

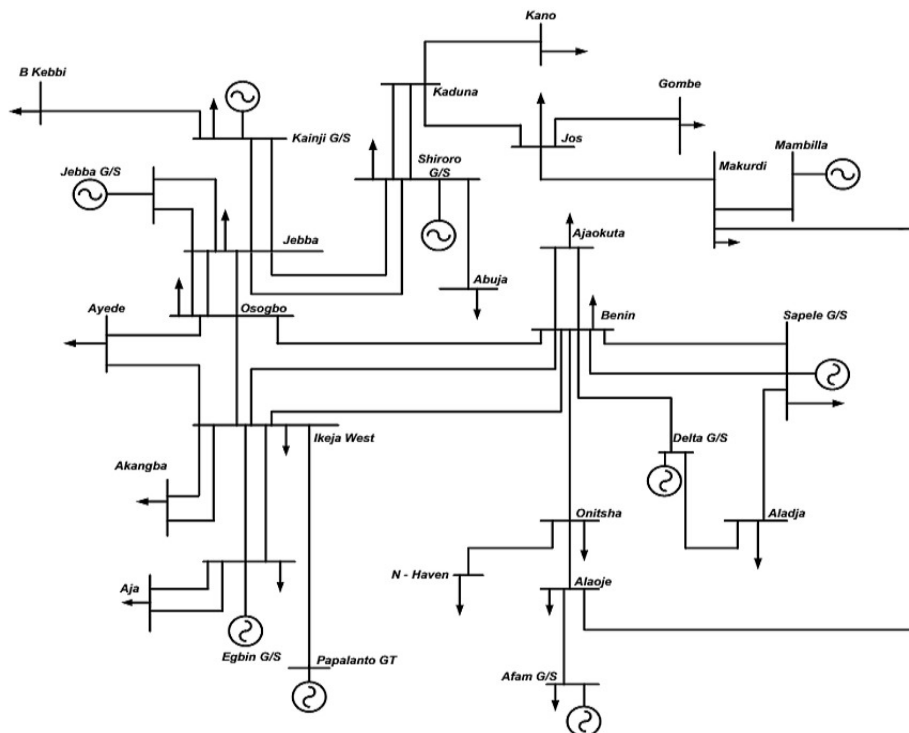

Figure 1: Nigerian 330 kV, 28 –Bus Transmission System

### III. Electric Power Quality

With the increasing use of non-linear loads and complexity of the power network, the power system faces challenges to deliver quality power to the consumers. This concept of Power Quality (PQ) mainly deals with three factors namely; reliability, quality of supply and customer service. However, poor PQ not only causes performance degradation and premature failure of electrical equipment but also results in increased system losses and financial loss. Therefore, apart from the reliability; continuous supply, the preference of the electricity consumers is now shifting towards quality power supply from the power company. Thus, optimum PQ can enhance performance, productivity and reduce losses in power system [21, 22].

There are various kinds of PQ disturbances, in electrical power system. They are classified into categories and their descriptions are important in order to classify measurement results and to describe [23, 24]. One of the major PQ problems is power system stability. Power system stability is the capability of power system, for a given initial operating condition, to maintain an operating equilibrium point after being subjected to a disturbance, with most system variables bounded so that practically the entire system remains intact. It deals with the ability to control the voltage level within a narrow band around normal operating voltage [25].

Based on the size of the disturbance, voltage stability can be classified as; short duration of variations (sags, swells, and interruption) and long duration variations (sustained interruptions, under voltages, and over voltages) [21, 26].

#### A. Short-duration voltage variations

This refers to the system's ability to maintain steady voltages when subjected to small perturbations such as incremental changes in system load. Short duration voltage variation may be categorized as; interruption, voltage sags (dips) and swells [22]:

- i. Interruption: This occurs when the supply voltage or load current decreases to less than 0.1 pu for a period of time not exceeding 1 min,
- ii. Voltage sag (dip): This is the reduction of Root Mean Square (RMS) voltage between 0.1 p.u. and 0.9 p.u. and lasting for duration between 0.5 cycles to 1 minute as shown in Figure 2 [24]. Also, the voltage sag in per unit of nominal system voltage is calculated as in Equation (1) [6]:

$$V_{sag}(p.u) = \frac{V(p.u) + kVA_{SC}}{kVA_{SLR} + kVA_{SC}} \quad (1)$$

where;  $V(p.u)$  is the actual system voltage,  $kVA_{LR}$  is the apparent power of motor locked rotor,  $kVA_{SC}$  is the system short-circuit apparent power.

- iii. Voltage swell: This is an increase in RMS voltage between 1.1 and 1.8 p.u at the power frequency for duration between 0.5 cycles to 1 minute. Voltage swells results in breakdown of insulation, overheating of electrical equipment and damage to electronic equipment. Its waveform is shown in Figure 3.

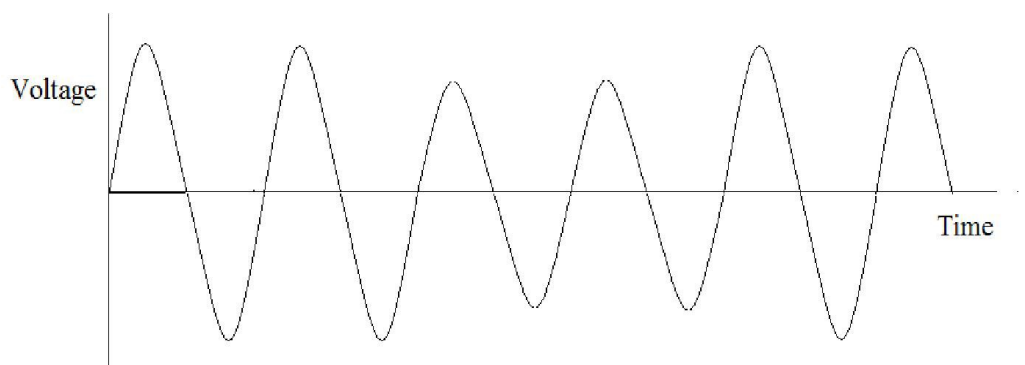

Figure 2: Voltage Sag

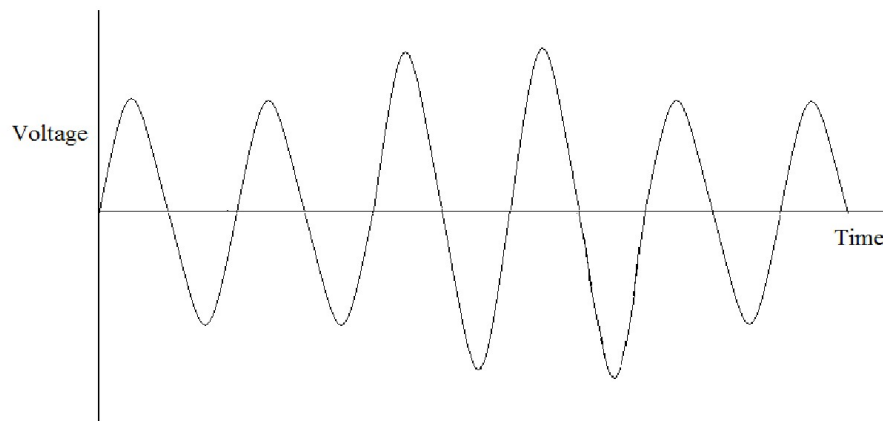

Figure 3: Voltage Swell

### B. Long-duration voltage variations

This refers to the system's ability to maintain steady voltages following large disturbances such as system faults, loss of generation, or circuit contingencies. The time frame of interest for voltage stability problems can stretch from 1 minute to several minutes [27]. Long duration variations sources include [28, 29]:

- i. Over Voltage: This is an increase in the RMS Alternating Current (AC) voltage greater than 110 percent (1.1 p.u) at the power frequency for duration longer than 1 min.
- ii. Under Voltage: This is a decrease in the RMS AC voltage to less than 90 percent (0.9 p.u) at the power frequency for duration longer than 1 min.
- iii. Sustained Interruptions: This occur when the supply voltage becomes zero for a period of time in excess of 1 min, the long-duration voltage variation is considered a sustained interruption.

## IV. Power Quality Improvement Techniques

In general, there are two approaches in finding solution to PQ problems. The first approach is load training, which guarantees that the equipment is less perceptive to power turbulence permitting the operation still below significant voltage deformation while the second approach is to mount line conditioning schemes that will suppress or neutralizes the power schemes turbulences [30]. Some of the effective and economic measures used for PQ solution can be identified as: Lightning and surge arresters, Thyristor based static switches, Energy storage systems, Harmonic filters among others [22, 31].

Recent development for mitigation of PQ based on voltage sag and interruption is done by placing of reactive power compensators between system and equipment. The compensator based on injection of reactive power and compensates the loss of active power coming from the system. These reactive power compensation techniques comprise of both series and shunt compensators. They enhances the system flexibility, reliability and as well as quick system restoration response to operational challenges. Many of the problems associated with transmission lines can be solved by injection or absorption of adequate reactive power [7, 32].

Shunt-type reactive compensation is extensively used in transmission system to execute the functions of voltage magnitude and PQ improvement. It is also used in enhancement of system stability [33]. On the other hand, series reactive compensation controls the overall series transmission line impedance by adding a voltage that opposes that of voltage drop in transmission line [34, 35].

Also, reactive power compensation can be supplied with the aid of both discrete and power electronic controllers. Discrete controllers are Load Tap-Changing Transformer (LTC), Capacitor (Series and Shunt) and Synchronous Compensators. Also, the recent development in power electronic devices led to the emergences of Flexible Alternating Current Transmission System (FACTS) devices which are referred to as power electronic controllers [7, 11].

The FACTS devices are an evolving technology to help electric utility companies and their applications in power system make bus voltage magnitude and power flow along the transmission lines more flexibly controlled [7, 36]. There are two generations for realization of power electronic-based FACTS controllers: the first generation which employs conventional thyristor-switched capacitors and reactors, and quadrature tap-changing transformers, and the second generation which employs Gate Turn-Off (GTO) thyristor-switched converters such as Voltage Source Converters (VSCs) [34, 35].

The first generation comprises of the Static Var Compensator (SVC), the Thyristor Controlled Series Capacitor (TCSC), and the Thyristor-Controlled Phase Shifter (TCPS). The second generation has produced the Static Synchronous Compensator (STATCOM), the Static Synchronous Series Compensator (SSSC), the Unified Power Flow Controller (UPFC), and the Interline Power Flow Controller (IPFC) [36]. Among the FACTS controllers, the most advanced type is the controller that employs Voltage Source Converter (VSC) as

synchronous sources. Also, of all the VSC the most widely used is the STATCOM controller. Computation and control of power flow for power systems embedded with STATCOM appear to be fundamental for power system analysis and planning purposes [7, 32].

#### A. Static synchronous compensator

The Static Synchronous Compensator (STATCOM) shown in Figure 4 is a Voltage Source Converter (VSC) electronic device with gate turn off thyristor and dc capacitor coupled with a step down transformer tied to a transmission line. It converts the dc input voltage into ac output voltages to compensate the active and reactive power of the system. STATCOM placed on a transmission network improve the voltage stability of a power system by controlling the voltage in transmission and distribution systems, improves the damping power oscillation in transmission system, and provides the desired reactive power compensation of a power system [35, 37].

From Figure 4, the exchange of reactive power between the converter and the AC system can be controlled by varying the amplitude of the 3-phase output voltage. However, if the amplitude of the output voltage is increased above that of the utility bus voltage, then current flows through the reactance from the converter to the AC system and the converter generates capacitive-reactive power for the AC system. Also, if the amplitude of the output voltage is decreased below the utility bus voltage, then the current flows from the AC system to the converter and the converter absorbs inductive-reactive power from the AC system [38, 39]. However, in which cases the STATCOM is said to be in floating state [8].

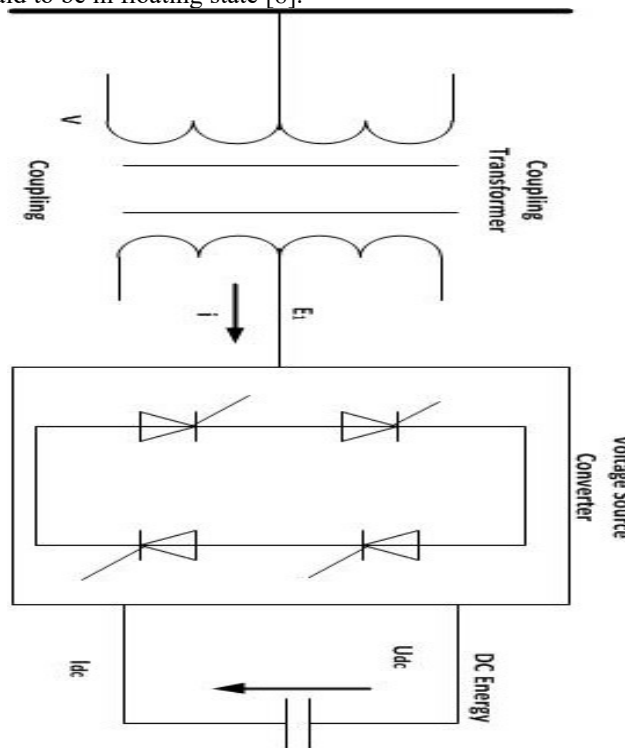

Figure 4: Static Synchronous Compensator

There are mainly two models of STATCOM that have been well tested in power systems; the Current Injection Model (CIM) and the Power Injection Model (PIM). The CIM model the STATCOM as a current source connected in shunt to the bus for voltage magnitude control. Whereas, the PIM model the STATCOM as shunt voltage source behind an equivalent reactance or impedance, which is also referred to as Voltage Source Model (VSM). This steady state PIM of STATCOM has proved reliable when incorporated in power systems [40].

The Mathematical models of the PIM of STATCOM are given as in Equations (2) to (4) [7, 41, 42]:

$$V_{STC} = V_k + Z_{SC} I_{STC} \quad (2)$$

$$I_{STC} = I_N - Y_{SC} V_k \quad (3)$$

$$I_N = Y_{SC} V_{STC} \quad (4)$$

The current expression in Equation (2.3) is transformed into a power expression by the VSC and power injected into bus  $k$  as shown in Equations (5) to (7) [7, 8]:

$$S_{STC} = V_{STC} I_{STC}^* \quad (5)$$

$$= V_{STC}^2 Y_{SC}^* - V_{STC} Y_{STC}^* V_k \quad (6)$$

$$S_k = V_{STC} V_{SC}^* V_k^* - V_k^2 Y_{SC}^* \quad (7)$$

where;  $V_{STC}$  is the STATCOM voltage magnitude,  $Y_{STC}$  is the STATCOM phase angle,  $I_{STC}^*$  is the STATCOM reference current,  $Y_{SC}^*$  is the admittance of the source converter,  $V_{STC}^*$  is the STATCOM reference voltage,  $V_k^*$  is the reference bus voltage at bus k,  $I_N$  is the Norton current,  $I_{STC}$  is the STATCOM current, and  $V_k$  is the bus voltage at bus k.

### B. Voltage sensitivity index

The Voltage Sensitivity Index (VSI) is the sensitivity analysis techniques which have the most attraction for optimal placement of reactive power sources [43]. The VSI determines the most voltage sensitive bus in the system. The bus with the highest value of VSI is the most sensitive bus and the reactive power compensator is placed on that bus for voltage profile improvement. For a single line diagram of power system connecting buses  $i$  and  $j$  shown in Figure 5 with source and load at sending and receiving ends respectively, the Voltage Sensitivity Index (VSI) is defined as in Equation (8) [23, 26, 44]:

$$VSI = \frac{Q_i}{\sum_{k=1}^n Q_k} \times \frac{\partial V_i}{\partial Q_k} \times \frac{Q_i^{Base}}{V_i^{Base}} \leq 1 \quad i = 1, 2, \dots, N_{Load} \quad (8)$$

Where;  $V_i$  is the voltage magnitude at bus  $i$ ,  $Q_i$  is the reactive load at bus  $i$ ,  $Q_k$  is the controller reactive load at bus  $k$ , the superscript *base* represents the base case.

Under normal operating conditions, VSI value obtained with Equation (8) should be less than unity. If the value of VSI is closer to zero, then the system will be more stable. If the value of VSI is high, then the system is vulnerable to instability.

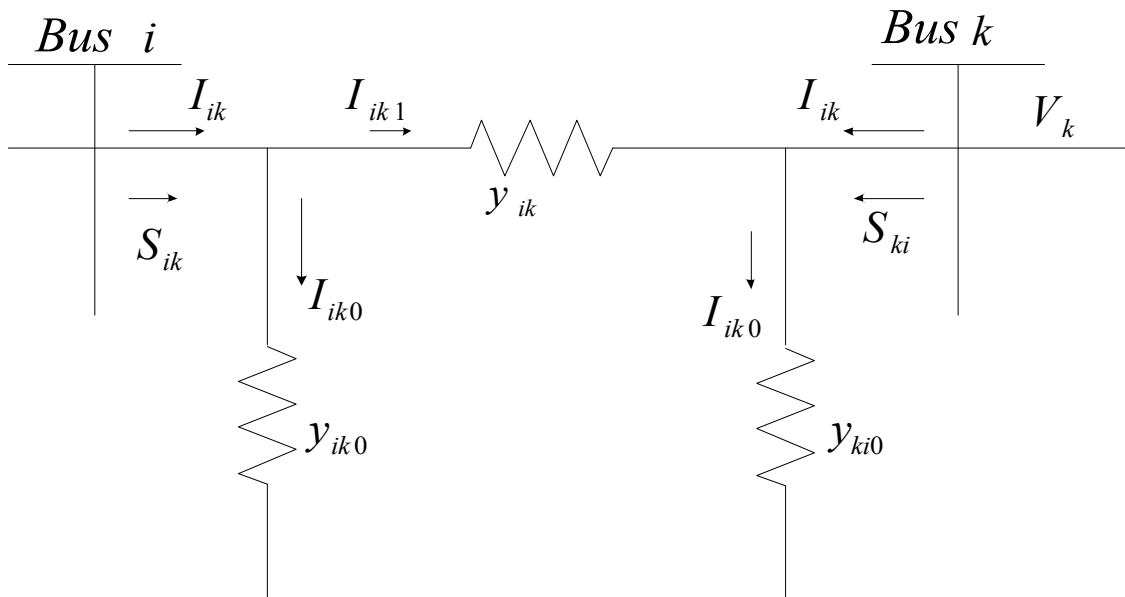

Figure 5: Single Line Diagram of Power System

## V. MATERIALS AND METHODS

This study analyzed and mitigates the PQ problem based on voltage sags on Nigerian 330 kV, 28.bus transmission system using STATCOM controller. Newton-Raphson (NR) load flow iteration method was adapted to perform the load flow for steady state and contingency (by varying the system reactive power for load buses between by 125 % from their base case value). A NR model with inclusion of power injection model of STATCOM was then formulated for mitigation of any voltage variation in the load buses and to maintain a prescribed level of supply voltage in the system. The suitable locations and the corresponding STATCOM size were obtained analytically using Voltage Sensitivity Index (VSI) and simulation was done in MATLAB/SIMULINK.

However, this study only addresses the problems of PQ based on voltage sag and its mitigation on Nigerian 330 kV power system using STATCOM power injection model. The power system under study was considered a balanced power network operating in sinusoidal quasisteady-state. Issues related with protection and costs of

transmission system are not considered in this study. The set of data such as line data, load data, bus voltages, transmission line currents, generators and other system components data required for this research was obtained from the National Control Centre (NCC) of the Transmission Company of Nigeria (TCN), Osogbo, Nigeria. The control parameters used for the analysis is shown in Table 1.

Table 5: Control Variable Limits

S/N	Control Variable	Limit
1	Generator Voltage ( $V_{Gi}$ )	(0.95 – 1.05) p.u
2	Reactive Base Load Variation	(50 – 125) %
3	Sag Voltage	(0.5 -.0.9) p.u.
4	Sag Duration	(0.5 -1) min
5	VSI Variation	(0.5 – 1)
6	Reactive Power of STATCOM	(0-100) MVAR

#### A. Newton-Raphson load flow for contingency analysis

The simulation for Newton-Raphson load flow for contingency was carried out in MATLAB by varying the reactive power for load buses by 125 % from the base case one at a time to check the stability of the system during failure of the components. The voltage magnitude violations was monitored for any bus close to the voltage rating limit of  $\pm 5\%$ . The simulation was done according to the following steps:

Step 1: The system data are input and the voltage magnitudes are initially set to  $1.0 p.u$

Step 2: The load flow at a given steady state condition of the power system are calculated.

Step 3: The numbers of load are generated by gradually increasing its reactive power demand while keeping the loads on the other buses at the base load.

Step 4: The system sag voltage and duration are calculated using equations (9) and (10)

$$V_{Sag} = \frac{V_i + S_{Con}}{S_G + S_{Con}} \quad (9)$$

$$D_{Sag} = \frac{Z_{Con}}{t_s} \times \frac{V_i}{1 - V_i} \quad (10)$$

where;  $S_{Con}$  is the apparent power occur during contingency,  $S_G$  is the generator apparent power,  $Z_{Con}$  is the impedance occur during contingency,  $t_s$  is the settle time constant.

Step 5: The admittance matrix are formed

Step 6: Linearized equation of the system and all elements of the Jacobian matrix are solved directly by optimally ordered triangularly factorization and elimination method.

Step 7: The process was repeated until the voltage difference reached the specified accuracy  $\pm 5\%$  voltage tolerance margin.

#### B. Newton-Raphson load flow with integration of STATCOM

The STATCOM controller along with NR load flow for contingency was formulated as a single-objective optimization problem. The voltage sag was treated as a PQ problem and was mitigated so as to improve the voltage stability of the transmission system. Therefore, the objective function in this study is formulated as in Equation (11) according to [6]:

$$optimize V_{Load} = \min \left( \frac{(1 - V_i)}{I_{STC}} P_{Load} + V_{Sag} \right) \quad (11)$$

where;  $V_{Load}$  is the system required load peak voltage,  $P_{Load}$  is the system rated MVA (load),  $V_i$  is the system peak source voltage,  $I_{STC}$  is the STATCOM controller current,  $V_{Sag}$  is the voltage sag.

The sag voltage minimization problem is subjected to the equality and inequality constraints as follows [17]:

Equality Constraints as in Equations (12) and (13):

$$P_{Gi} - P_{Di} - \sum_{i=1}^N |V_i| |V_j| |Y_{ij}| \cos(\theta_{ij} - \delta_i + \delta_j) = 0 \quad (12)$$

$$Q_{Gi} - Q_{Di} - \sum_{i=1}^N |V_i| |V_j| |Y_{ij}| \sin(\theta_{ij} - \delta_i + \delta_j) = 0 \quad (13)$$

Inequality Constraints as in equations (14) to (17):

$$P_{Gi}^{Min} \leq P_{Gi} \leq P_{Gi}^{Max} \quad i = 1, \dots, NG \quad (14)$$

$$Q_{STC}^{Min} \leq Q_{STC} \leq Q_{STC}^{Max} \quad i = 1, \dots, N_{STC} \quad (15)$$

$$V_{STC}^{Min} \leq V_{STC} \leq V_{STC}^{Max} \quad i = 1, \dots, N_B \quad (16)$$

$$S_i \leq S_i^{Max} \quad i = 1, \dots, nl \quad (17)$$

The model of the STATCOM for its inclusion in power flow algorithm is derived from its equivalent circuit, shown in Figure 6.

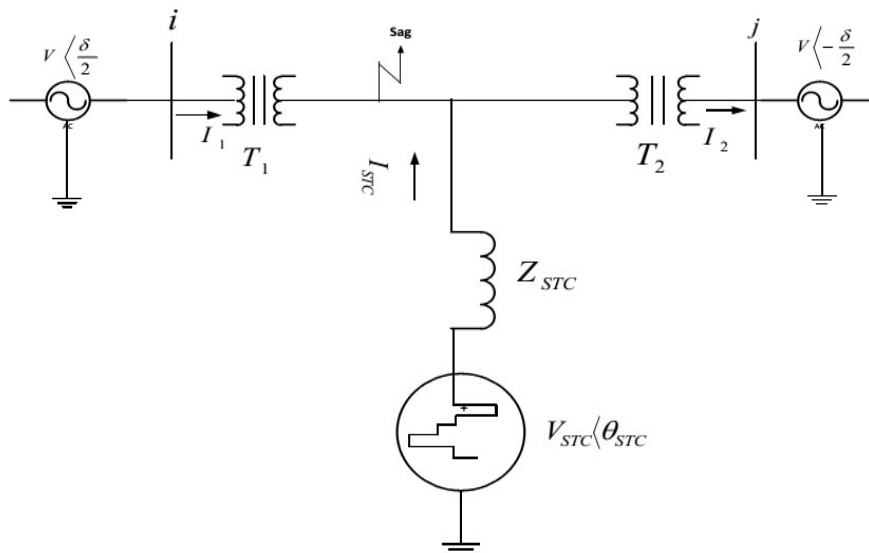

Figure 6: Circuit Diagram of STATCOM PIM Compensated Transmission Line  
 The current in terms of the bus admittance matrix is given as in Equation (18):

$$I_i = \sum_{j=1}^n Y_{ij} V_j \quad (18)$$

The contingency complex power flow equations for both active and reactive power for uncompensated transmission system are given in Equations (19) and (20):

$$P_{Coni} = P_{Di} - \sum_{j=1}^n V_i V_j Y_{ij} \cos(\theta_{ij} + \delta_j - \delta_i) \quad (19)$$

$$Q_{Coni} = Q_{Di} - \sum_{j=1}^n V_i V_j Y_{ij} \sin(\theta_{ij} + \delta_j - \delta_i) \quad (20)$$

The STATCOM voltage source is given in equation (21):

$$E_{STC} = V_{STC} (\cos \delta_{STC} + j \sin \delta_{STC}) \quad (21)$$

The power flow equation for the STATCOM is given in equations (22) to (23):

$$S_{STC} = V_{STC} I_{STC}^* \quad (22)$$

$$= V_{STC} Y_{STC}^* (V_{STC}^* - V_{ij}^*) \quad (23)$$

The active and reactive power equations of the STATCOM are obtained as in Equations (24) and (25):

$$P_{STC} = V_{STC}^2 G_{STC} + V_{STC} V_{ij} [G_{STC} \cos(\delta_{STC} - \theta_{ij}) + B_{STC} \sin(\delta_{STC} - \theta_{ij})] \quad (24)$$

$$Q_{STC} = -V_{STC}^2 G_{STC} + V_{STC} V_{ij} [G_{STC} \sin(\delta_{STC} - \theta_{ij}) + B_{STC} \cos(\delta_{STC} - \theta_{ij})] \quad (25)$$

The current drawn by the STATCOM is calculated using Equation (26):

$$I_{STC} = I_1 \sin \theta_1 - I_2 \sin \theta_2 \quad (26)$$

The active and reactive power injected by STATCOM is in Equations (27) and (28):

$$P_{ij} = V_{ij}^2 G_{STC} + V_{ij} V_{STC} [G_{STC} \cos(\theta_{ij} - \delta_{STC}) + B_{STC} \sin(\theta_{ij} - \delta_{STC})] \quad (27)$$

$$Q_{ij} = -V_{ij}^2 G_{STC} + V_{ij} V_{STC} [G_{STC} \sin(\theta_{ij} - \delta_{STC}) + B_{STC} \cos(\theta_{ij} - \delta_{STC})] \quad (28)$$



The linearized NR power flow for STATCOM PIM in Equation (29):

$$\begin{bmatrix} \Delta P_{ij} \\ \Delta Q_{ij} \\ \Delta P_{STC} \\ \Delta Q_{STC} \end{bmatrix} = \begin{bmatrix} \frac{\partial P_{ij}}{\partial \theta_{ij}} & \frac{\partial P_{ij}}{\partial V_{ij}} V_{ij} & \frac{\partial P_{ij}}{\partial \delta_{STC}} & \frac{\partial P_{ij}}{\partial V_{STC}} V_{STC} \\ \frac{\partial Q_{ij}}{\partial \theta_{ij}} & \frac{\partial Q_{ij}}{\partial V_{ij}} V_{ij} & \frac{\partial Q_{ij}}{\partial \delta_{STC}} & \frac{\partial Q_{ij}}{\partial V_{STC}} V_{STC} \\ \frac{\partial P_{STC}}{\partial \theta_{ij}} & \frac{\partial P_{STC}}{\partial V_{ij}} V_{ij} & \frac{\partial P_{STC}}{\partial \delta_{STC}} & \frac{\partial P_{STC}}{\partial V_{STC}} V_{STC} \\ \frac{\partial Q_{STC}}{\partial \theta_{ij}} & \frac{\partial Q_{STC}}{\partial V_{ij}} V_{ij} & \frac{\partial Q_{STC}}{\partial \delta_{STC}} & \frac{\partial Q_{STC}}{\partial V_{STC}} V_{STC} \end{bmatrix} \begin{bmatrix} \Delta \theta_{ij} \\ \frac{\Delta V_{ij}}{V_{ij}} \\ \Delta \delta_{STC} \\ \frac{\Delta V_{STC}}{V_{STC}} \end{bmatrix} \quad (29)$$

The new state variables of the STATCOM are generated as in Equations (30) and (31):

$$|V_{STC}^{(i+1)}| = |V_{STC}^{(i)}| + \Delta |V_{STC}^{(i)}| \quad (30)$$

$$\delta_{STC}^{(i)} = \delta_{STC}^i + \Delta \delta_i^i \quad (31)$$

The Voltage Sensitivity Index (VSI) is calculated using Equation (32):

$$VSI = \frac{Q_{ij}}{\sum_{i=1}^n Q_{STC}} \times \frac{\partial V_{ij}}{\partial Q_{STC}} \times \frac{Q_i^{Base}}{V_i^{Base}} \quad (32)$$

where:  $V_{STC}$  is the STATCOM voltage magnitude,  $\delta_{STC}$  is the STATCOM phase angle,  $I_{STC}^*$  is the STATCOM reference current,  $Y_{STC}^*$  is the STATCOM reference admittance,  $V_{STC}^*$  is the STATCOM reference voltage,  $V_{ij}^*$  is the reference bus voltage at bus k,  $G_{STC}$  is the STATCOM conductance.

The simulation for NR without and with STATCOM controller for mitigating the Power Quality (PQ) problem based on voltage sag during contingency was carried out in MATLAB according to the flowchart in Figure 7.

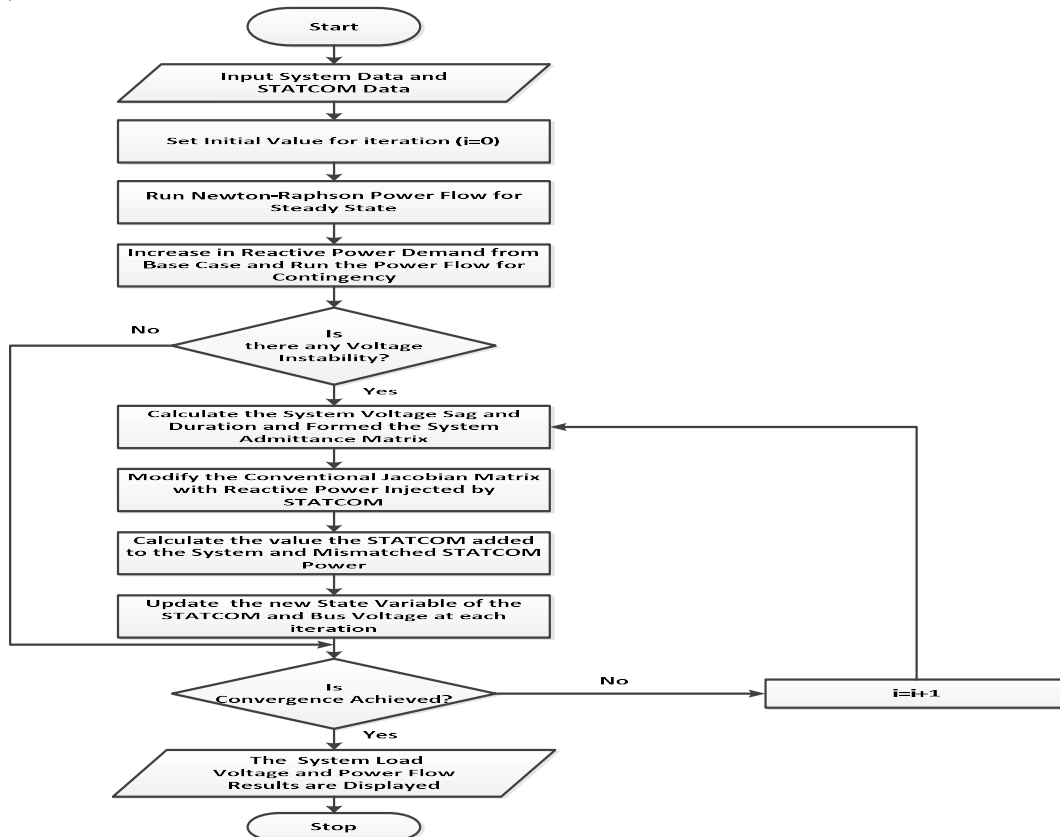

Figure 7: Flowchart of Newton-Raphson with inclusion of STATCOM

### C. Implementation of Voltage Sensitivity Index

The Voltage Sensitivity Index (VSI) was used to find the most sensitive bus for allocating the STATCOM controller in the power system. The VSI determines the most voltage sensitive bus in the system. The bus with the highest value of VSI is the most sensitive bus and the STATCOM controller was placed on the bus for PQ improvement. Simulation was done in MATLAB/SIMULINK to solve the resulting optimization method based on objective functions (sag minimization) and the VSI was calculated. The flowchart in Figure 8 is to obtain the desired optimization placement result.

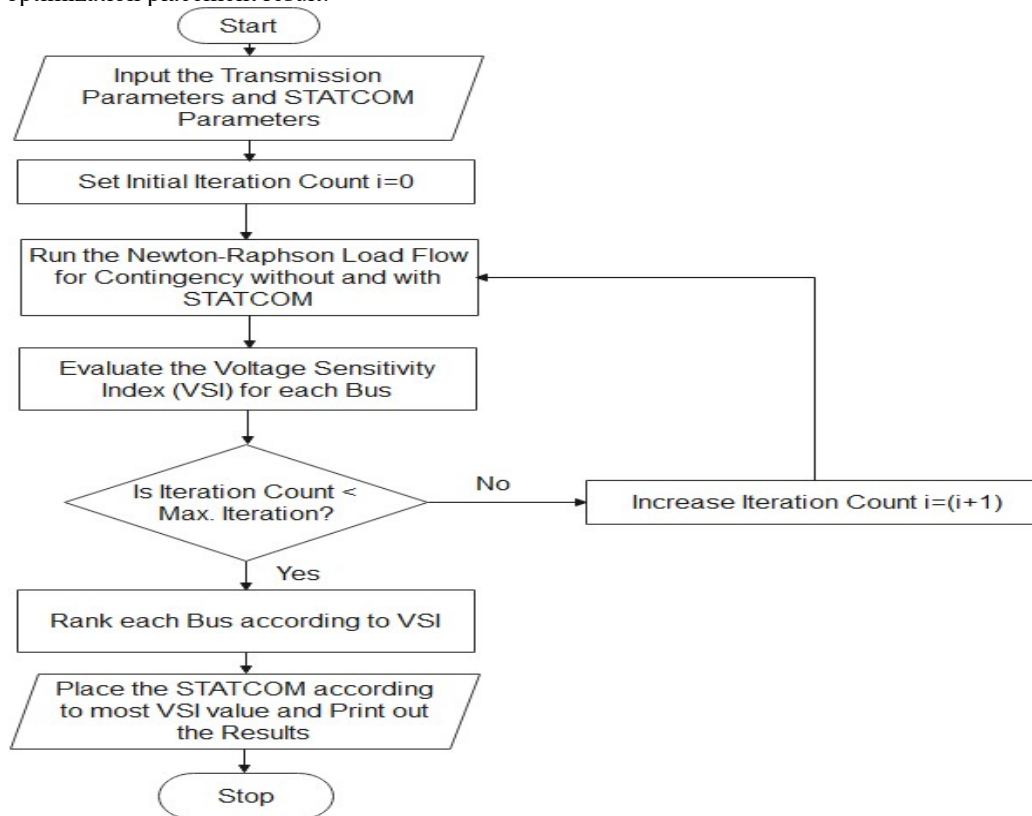

Figure 8: Flowchart of Voltage Sensitivity Index for Optimal STATCOM Placement

## VI. RESULTS AND DISCUSSION

The Nigerian 28-bus transmission system reactive power for load buses were varied by 125 % of their base case values and load flow analysis was performed without and with STATCOM controller using NR iterative method. The sag magnitude and duration in the system were monitored and recorded. The stability level of the system was determined. The simulation results are presented in Tables 2 to 3 and Figure 9, respectively.

Table 2 showed the results of power flow of the system for steady states. From the Table 2, buses whose voltage falls short of the  $\pm 5\%$  tolerance margin of the voltage criterion are buses 6, 13, 16 and 17 with voltage magnitude of 1.0580, 0.9360, 0.9040 and 1.0510 p.u., respectively. These buses are the potential buses for location of STATCOM controller so as to mitigate any concurrency of contingency. However, the system is assumed not stable as the system indicated low voltage at some buses. The results in line with the results obtained from [9] using Static Var Compensators (SVC) and [40] using reliability indices, respectively, to examine the quality of electric supply in Nigeria.

Table 3 presented the results of power flow of the system for contingency without and with STATCOM controller at 125 % loading. It was observed that buses 3, 4, 5, 6, 7, 8, 9, 10, 12, 13, 14, 15, 16, 17, 19, 20, 22, 25 and 26, respectively, were the buses for all the reactive power variation from base case values, whose voltage falls short of the  $\pm 5\%$  tolerance margin of the voltage criterion. This low voltage is an indication that the system is not stable. Thus, these buses are the potential bus for location of STATCOM controller as to maintain the prescribed level of supply voltage of  $\pm 5\%$  voltage tolerance margin and to mitigate the PQ problem (voltage sag) in the system. Also, voltage sag problem were detected at these buses with high sag duration. It was observed that as the reactive powers in these buses are increased, the value of voltage magnitude in these buses are also reduced compared to base case value.

With application of STATCOM controller in the system during contingency, it was observed that all the load buses (buses 3, 4, 5, 6, 7, 8, 9, 10, 12, 13, 14, 15, 16, 17, 19, 20, 22, 25 and 26, respectively) whose voltage

falls short of the  $\pm 5\%$  tolerance margin of the voltage criterion was rectified by having the voltage magnitude at all the buses within voltage limit. The values of voltage magnitude at these buses with STATCOM controller were 1.0038, 1.0003, 1.0010, 1.0012, 1.0022, 1.0100, 1.0000, 1.0002, 1.0011, 1.0000, 1.0000, 1.0003, 1.0000, 1.0004, 1.0000, 1.0001, 1.0000, 1.0000 and 1.0007 p.u., respectively.

Also with application of VSI with STATCOM during contingency, buses 5, 12, 8 and 16 accordingly with VSI value of 0.8091, 0.7909, 0.7905 and 0.7022, respectively, and STATCOM reactive power of 72.46, 50.86, 65.35 and 53.75 MVAR, respectively were revealed as the potential buses for best location of STATCOM controller for averting against voltage sag problem in the system. These buses are the most sensitive buses accordingly for optimal placement of the STATCOM controller in the system.

Also, Figure 9 showed the system relationship between sag voltage and duration for contingency. Nineteen sag triggering point at duration of 0.523, 0.5901, 0.7336, 0.5203, 0.6100, 0.7419, 0.5693, 0.6355, 0.6512, 0.7143, 0.6921, 0.6890, 0.5972, 0.6892, 0.6910, 0.7101, 0.6783, 0.7123 and 0.6874 sec were detected at buses 3, 4, 5, 6, 7, 8, 9, 10, 12, 13, 14, 15, 16, 17, 19, 20, 22, 25 and 26, respectively, without STATCOM controller. The values of sag voltage with STATCOM controller at these buses were 0.0074, 0.0071, 0.0017, 0.0097, 0.0069, 0.0078, 0.0064, 0.0048, 0.0021, 0.0085, 0.0085, 0.0021, 0.0054, 0.0071, 0.0081, 0.0074, 0.0073, 0.0082, 0.0066 and 0.0087 p.u., respectively. The voltage sag in the system was minimized and control effectively. This indicates that the system is stable and secure from voltage sag problem.

Table 2: Power Flow Result of Nigerian 28-Bus Transmission System for Steady State

Steady State					
Bus No	Bus Type	Voltage Magnitude (p.u)	Voltage Angle (deg)	Load (MW)	Load (MVAR)
1	Swing	1.0500	0.0000	68.9	51.7
2	PV	1.0500	11.2600	0	0
3	PQ	1.0450	-0.2800	274.4	205.8
4	PQ	1.0080	0.5000	344.7	258.5
5	PQ	1.0160	0.9300	633.2	474.9
6	PQ	1.0580	5.4100	13.8	10.3
7	PQ	1.0460	9.7100	96.5	72.4
8	PQ	1.0380	5.7700	383.3	287.5
9	PQ	0.9830	1.5700	275.8	206.8
10	PQ	1.0290	7.0100	201.2	150.9
11	PV	1.0500	8.9100	52.5	39.4
12	PQ	1.0300	8.300	427	320.2
13	PQ	0.9360	0.0800	177.9	133.4
14	PQ	0.9780	2.8500	184.6	138.4
15	PQ	1.0100	10.1400	114.5	85.9
16	PQ	0.9040	1.6200	130.6	97.9
17	PQ	1.0510	12.4500	11	8.2
18	PV	1.0500	12.7600	0	0
19	PQ	0.9780	8.7700	70.3	52.7
20	PQ	1.0090	4.7000	193	144.7
21	PV	1.0500	15.6600	7	5.2
22	PQ	0.9920	-4.2700	220.6	142.9
23	PV	1.0500	6.8700	70.3	36.1
24	PV	1.0500	7.3000	20.6	15.4
25	PQ	0.9800	17.2500	110	89
26	PQ	1.0000	2.6300	290.1	145
27	PV	1.0500	41.8800	0	0
28	PV	1.0500	5.4900	0	0

Table 3: Power Flow Result of Nigerian 28-Bus Transmission System without and with STATCOM at 125 % Loading

Bus No	without STATCOM		with STATCOM		Voltage Sensitivity Index (VSI)
	Voltage Magnitude (p.u)	Voltage Angle (deg)	Voltage Magnitude (p.u)	Voltage Angle (deg)	
1	1.0500	0.0000	1.0500	0.0000	0.0517
2	1.0500	11.2600	1.0500	8.8829	0.0037
3	0.8420	0.1200	1.0038	-1.0700	0.2188
4	0.7500	0.1000	1.0003	-0.4551	0.2106
5	0.7900	1.3300	1.0010	-2.9170	0.8091
6	0.8030	5.0100	1.0012	2.9898	0.0105
7	0.8080	10.1100	1.0022	7.3291	0.0460
8	0.7960	5.3700	1.0100	7.7580	0.7905
9	0.7580	1.9700	1.0000	-0.8691	0.3781
10	0.7620	6.6100	1.0002	9.5400	0.1302
11	1.0500	8.9100	1.0500	4.7871	0.0801
12	0.7520	7.9000	1.0011	9.0900	0.7909
13	0.7540	0.4800	1.0000	-3.1991	0.1497
14	0.7510	2.4500	1.0000	4.6000	0.1705
15	0.8660	10.5400	1.0003	5.2456	0.0590
16	0.7500	1.2200	1.0000	-4.2300	0.7022
17	0.8890	12.8500	1.0004	7.5927	0.0002
18	1.0500	12.7600	1.0500	7.8803	0.0003
19	0.7560	9.1700	1.0000	9.1300	0.0113
20	0.8320	4.3000	1.0001	-2.6657	0.1789
21	1.0500	15.6600	1.0500	7.6020	0.0042
22	0.7740	-4.6700	1.0000	-6.2681	0.1801
23	1.0500	6.8700	1.0500	8.7900	0.0221
24	1.0500	7.3000	1.0500	4.9980	0.0020
25	0.7610	17.2500	1.0000	-8.2000	0.0710
26	0.7550	2.2300	1.0007	-3.1693	0.1478
27	1.0500	41.8800	1.0500	9.0520	0.0011
28	1.0500	5.4900	1.0500	2.1985	0.0032

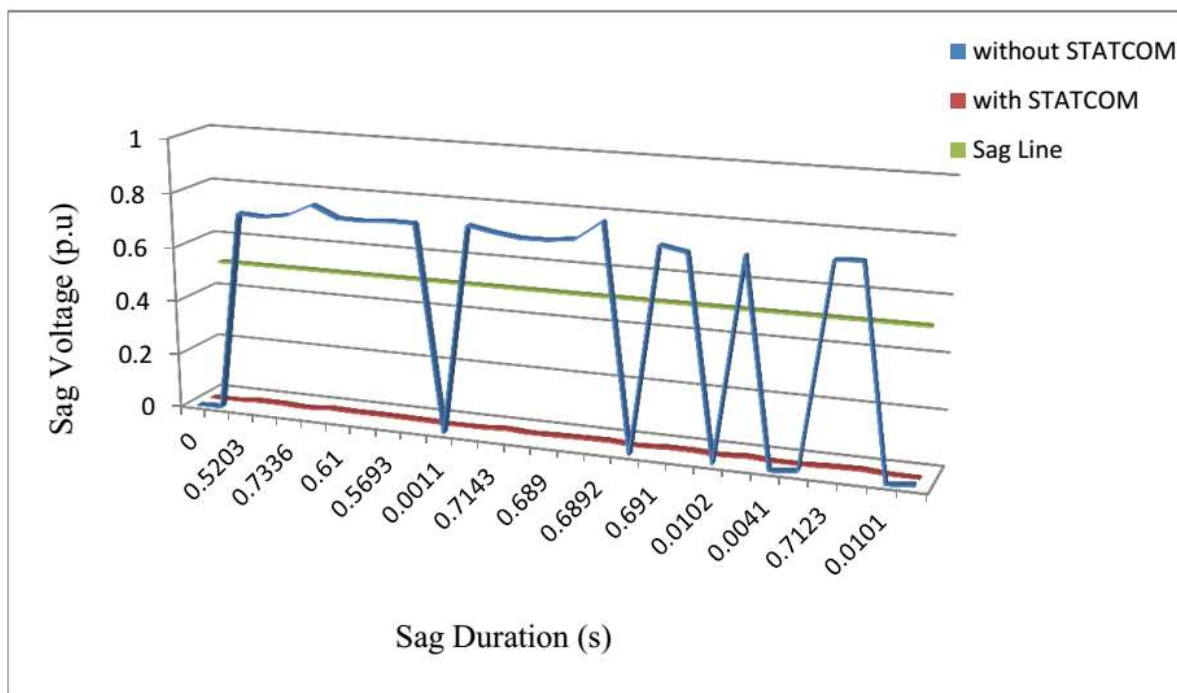

Figure 9: Sag Voltage with Duration for Nigeria 28-Bus System

## VII. CONCLUSION

This study has successfully presented the application of STATCOM controller analytically using VSI for analysis of PQ problem based on voltage sag on Nigerian 330 kV transmission system. Simulations were carried out on MATLAB/SIMULINK based on two scenarios; the base case and the contingency. The study revealed that Nigerian 28-bus transmission system is not stable for steady state. Similarly, with the contingency analysis, the voltage magnitude of the load buses for the system falls short of the  $\pm 5\%$  tolerance margin of the voltage criterion and voltage sag problem were detected with high sag duration. This verified the radial nature of the Nigeria power system which makes it to experience voltage instability more often.

With application of STATCOM controller during contingency, all the load buses whose voltage falls short of the  $\pm 5\%$  tolerance margin of the voltage criterion was rectified within voltage limit and the voltage sag in the system was minimized and regulated effectively. The simulation results obtained verify the accuracy and efficiency of the STATCOM for mitigation of PQ problem (sag) on power transmission system. Thus, the application of the STATCOM with VSI resulted in improved overall efficiency of the electrical power system. Therefore, it can be safely concluded that, the approach applied in this study is credible, efficient and suitable for averting against PQ problem (sag) in power transmission system.

## VIII. ACKNOWLEDGMENT

I thank the management of the National Control Centre (NCC) of the Transmission Company of Nigeria (TCN), Osogbo, Nigeria for providing the set of data used in this work. Also, I thank Mr. A. W. Eboda for his assistance in typesetting and editing of this work.

### Funding

This study did not received any external funding.

### Conflicts of Interest

The author declares no conflict of interest.

## IX. REFERENCES

- [1] Z. J. Paracha and S. A. Qureshi (2004). Application of power quality management techniques and methods in power system of Wapda Pakistan. *www.researchjournal.com*, 10.1.1.549.7015: 1-6.
- [2] N. V. Emodi and S. D. Yusuf (2015). Improving electricity access in Nigeria: obstacles and the way forward. *International Journal of Energy Economics and Policy*, **5** (1): 335-351.
- [3] M. O. Okelola (2018). Power quality events classification on real-time voltage waveform using short time Fourier transform and Bayes classifier. *International Journal of Applied Science and Technology*, **8** (2): 82-90.
- [4] P. Jena, S. Mohapatra, S. Mishra, B. Panda and A. Majumdar (2019). Power quality improvement by

- reduction of total harmonic distortion (THD) using PWM Inverter. *International Journal of Innovative Technology and Exploring Engineering (IJITEE)*, **9** (2): 1641-1643.
- [5] S. Balasubramanian and T. S. Sivakumaran (2017). Fuzzy logic controller implementation of power quality improvement using UPQC. *Circuits and Systems*, **8**:202-226.
- [6] S. Patra (2016). Power quality improvement in fuel cell based hybrid power system using STATCOM. *Student Journal of Energy Research*, **1** (1): 1-8.
- [7] I. D. Fajuke (2019). Optimal siting and sizing of static synchronous compensator on longitudinal transmission system for power loss reduction using firefly algorithm. *Unpublished Master Thesis Submitted to Faculty of Engineering and Technology, Ladoke Akintola University of Technology*, 1-139.
- [8] D. Lumbreras, E. Gálvez, A. Collado and J. Zaragoza (2020). Trends in power quality, harmonic mitigation and standards for light and heavy industries: A Review, [www.mdpi.com/journal/energies](http://www.mdpi.com/journal/energies), doi:10.3390/en13215792, **13**, 5792: 1-24.
- [9] P. I. Obi, J. A. Ulasí, K. J. Offor and G. C. Chidolue (2013). Improving electric power quality in Nigerian existing 330kv 28 bus electric power systems using static var compensator system. *International Journal of Engineering Research and Technology (IJERT)*, **2** (8): 1060-1066.
- [10] I. Annapoorani (2017). Series active power filter for power quality improvement based on distributed generation. *International Journal of Applied Engineering Research*, **12** (22): 12214-12218.
- [11] M. N. Nwohu, B. Tanko, H. Ohize, A. A. Sadiq and A. A. Usman (2017). Harmonic load modeling: a case study of 33 kV Abuja steel mill feeder. *Nigerian Journal of Technology (NIJOTECH)*, **36** (4): 1184 – 1190.
- [12] R. Mallajoshula and I. E. S. Naidu (2019). Power quality issues in power systems. *International Journal of Innovative Technology and Exploring Engineering (IJITEE)*, **9** (2S3): 308-313.
- [13] G. A. Adepoju, M. A. Sanusi and M. A. Tijani (2017). Application of SSSC to the 330 kV Nigerian transmission network for voltage control. *Nigerian Journal of Technology (NIJOTECH)*, **36** (4): 1258 – 1264.
- [14] P. Xiao (2007). New techniques to improve power quality and evaluate stability in modern all-electric naval ship power systems. *Doctoral Dissertations Submitted to Department of Electrical and Computer Engineering, Scholars' Mine*: 1-104.
- [15] G. A. Ajenikoko, A. W. Eboda, O. Adigun, A. Olayinka, S. O. Oni and L. Adelowo (2018). Analysis of power sector performance: Nigeria as a case study. *Mathematical Theory and Modeling*, **8**(.8): 64-71.
- [16] G. A. Ajenikoko, A. W. Eboda and B. S. Adeleke (2019). Development of a newton-raphson symmetrical component based technique for fault analysis on Nigerian 330 KV transmission lines. *Journal of Natural Sciences Research*, **9**(16): 20-31.
- [17] M. Y. Banwo and K. Ighodalo (2020). The Nigerian power sector reforms: overcoming post-privatization challenges. [www. Banwo-ighodalo.com](http://www.Banwo-ighodalo.com); 1-6.
- [18] A. S. Sambo (2008). Matching supply with demand in Nigeria. *Paper presented at the National Workshop on the Participation of State Governments in the Power Sector, Ladi Kwali Hall, Sheraton Hotel and Towers, Abuja*, 1-5.
- [19] M. Y. Roche, H. Verolme, C. Agbaegbu, T. Binnington, M. Fishedick and E. O. Oladipo (2019). Achieving sustainable development goals in Nigeria's power sector: assessment of transition pathways. *Climate Policy*, DOI: 10.1080/14693062.2019.1661818: 1-21.
- [20] I. K. Okakwu and E. A. Ogujor (2017). Transient stability analysis of the Nigeria 330-kV transmission network. *American Journal of Electrical Power and Energy Systems*, **6** (6): 79-87.
- [21] M. O. Okelola, A. L. Amoo and R. K. Soremekun (2019). Power quality events segmentation in a voltage waveform using joint triggering point detection scheme. *FUOYE Journal of Engineering and Technology*, **4** (1): 8-12.
- [22] K. S. Mandal and H. S. Sheikh (2020). The power quality improvement with harmonic reduction and stabilizing main grid. *International Research Journal of Engineering and Technology (IRJET)*, **7** (9): 2507-2510.
- [23] R. Martinek, J. Manas, J. Zidek and P. Bilik (2013). Power quality improvement by shunt active performance filters emulated by artificial intelligence techniques. *2<sup>nd</sup> International Conference on Advances in Computer Science and Engineering*, 157-161.
- [24] T. G. More, P. R. Asabe and S. Chawda (2014). Power quality issues and its mitigation techniques. *Int. Journal of Engineering Research and Applications* [www.ijera.com](http://www.ijera.com), **4** (4): 170-177.
- [25] D. S. Kumar and G. V. Madhav (2015). Power quality improvement with a shunt active power filters using MATLAB/Simulink. *International Journal of Innovative Research In Electrical, Electronics, Instrumentation And Control Engineering*, **3** (1): 1-7.
- [26] S. Hussain, K. Satyanarayana and B. K. V. Prasad (2011). Power quality improvement by using active power filters. *International Journal of Engineering Science and Advanced Technology*, **1** (1): 1 – 7.

- [27] M. F. Zakaria and V. K. Ramachandramurthy (2017). Assessment and mitigation of power quality problems for puspiti triga reactor (RTP). *AIP Conference Proceedings* 1799; <https://doi.org/10.1063/1.4972909>: 1-10.
- [28] S. Ibrahim, S. Prakash and A. K. Bhardwaj (2013). Power quality improvement performance using hybrid (solar wind) energy for distributed power generation. *International Journal of Advanced Research in Computer and Communication Engineering*, **2** (10): 4124-4131.
- [29] K. Schipman and F. Delincé (2010). The importance of good power quality. *ABB Power Quality Products, Belgium*, **5** (4): 1-20.
- [30] K. A. Neelima, A. S. Sastry, B. Kshithija, K. Goutam and G. H. Chandra (2020). Mitigation of harmonics in power transmission network using filters. *International Journal of Recent Technology and Engineering (IJRTE)*, **9** (1): 1283-1288.
- [31] H. Eriksson and M. Findell (2010). Capacitors and filters, improving power quality for efficiency and reliability. *ABB Publication IHSM 9543 31-01en, Edition 1, 2010-11*: 1-24.
- [32] R. H. S. Soeprapto, A. F. A. Abd-Rahman, M. N. M. Nasir and Z. H. Bohari (2014). Analyzing of a shunt compensator installation. *The International Journal of Engineering and Science*, **3** (12): 61-67.
- [33] I. K. Kiran and J. A. Laxmi (2011). Shunt versus Series compensation in the improvement of Power system performance. *International Journal of Applied Engineering Research, Dindigul*, **2** (1): 29-37.
- [34] O. Gavasheli (2007). Optimal placement of reactive power supports for loss minimization: the case of a Georgian regional power grid. *Master Thesis Submitted to Division of Electric Power Engineering Department of Energy and Environment Chalmers University of Technology Göteborg, Sweden*: 1-74.
- [35] G. Gupta, N. H. Rai and D. Kumar (2020). Mitigation techniques of power quality issues in electrical power system. *International Research Journal of Engineering and Technology (IRJET)*, **7** (1): 974-979.
- [36] E. Omorogiuwa and S. O. Onohaebi (2015). Optimal location of IPFC in Nigeria 330 kV integrated power network using Genetic Algorithm technique. *Journal of Electrical and Electronic Systems*, [doi:10.4172/2332-0796.1000145](https://doi.org/10.4172/2332-0796.1000145), **4** (1): 1-8.
- [37] P. K. Sahoo, K. P. Ray and P. Das (2016). Power quality improvement of single phase grid connected photovoltaic system. *International Journal of Emerging Electric Power Systems*, 2016;20160097: 1-9.
- [38] O. P. Mahela and S. R. Ola (2013). Optimal capacitor placement for loss reduction in electric transmission system using genetic algorithm. *International Journal of Electrical and Electronics Engineering, Research*, **3** (2): 59-68.
- [39] H. U. Patil (2015). Harmonic resonance in power transmission systems due to the addition of shunt capacitors. A Master Thesis Submitted to Post Graduate School, Arizona State University: 1- 119.
- [40] A. H. Bindu and M. D. Reddy (2013). Economic load dispatch using cuckoo search algorithm. *International Journal of Engineering Research and Applications*, **3** (4): 498-502.
- [41] G. A. Adepoju, O. A. Komolafe and D. O. Aborisade (2011). Power flow analysis of the Nigerian transmission system incorporating FACT controller. *International Journal of Applied Science and Technology*, **1** (5), 186-200. 2011.
- [42] C. M. Wankhade and A. P. Vaidya (2012). Optimal power flow evaluation of power system using Genetic Algorithm. *International Journal of Power System Operation and Energy Management*, **1** (4), 67-72.
- [43] G. Gurguiatu, I. Vechiu, and T. Munteanu (2011). Power quality improvement using renewable energy. DOI:10.24084/repqj09.437, [www.researchgate.net/publication:1-5](http://www.researchgate.net/publication:1-5).
- [44] S.O. Okozi, P. C. Chukwudi, M. Olubiwe and K. C. Obute (2018). Reliability assessment of Nigerian power systems case study of 330kv transmission lines in Benin sub – region. *International Journal of Engineering Research and Technology (IJERT)*, **7** (03): 399-405.