

Cite this: DOI: 10.1039/c0xx00000x

www.rsc.org/xxxxxx

ARTICLE TYPE

Intracomplex general acid/base catalyzed cleavage of RNA phosphodiester bonds: the leaving group effect

Tuomas Lönnberg^{*a} and Mikko Luomala^a

Received (in XXX, XXX) Xth XXXXXXXXX 20XX, Accepted Xth XXXXXXXXX 20XX

DOI: 10.1039/b000000x

The general acid/base catalyzed cleavage of a number of alkyl esters of uridine-3′-(and -5′-)phosphate has been studied by utilizing a cleaving agent, in which the catalytic moiety (a substituted 1,3,5-triazine) is tethered to an anchoring Zn^{II}:cyclen moiety. Around pH 7, formation of a strong ternary complex between uracil, Zn^{II} and cyclen brings the general acid/base catalyst close to the scissile phosphodiester linkage, resulting in rate acceleration of 1-2 orders of magnitude with the uridine-3′-phosphodiester. Curiously, no acceleration was observed with their 5′-counterparts. A β_{lg} value of -0.7 has been determined for the general acid/base catalyzed cleavage, consistent with a proton transfer to the leaving group in the rate-limiting step.

Introduction

General acid/base catalysis is the strategy employed by the small ribozymes, as well as RNase A, for the cleavage of RNA phosphodiester linkages.¹⁻³ The reaction has been extensively studied with simple buffer acids and bases but the results have been somewhat ambiguous due to the very high buffer concentrations required to overcome the inefficiency of the catalysis in such systems.⁴⁻⁹ While it is agreed that sufficiently basic buffers ($\text{p}K_{\text{a}} > 8$) serve as general bases deprotonating the attacking 2′-OH which leads to more or less concerted breakdown of the dianionic phosphorane,⁷⁻⁹ a number of alternative mechanisms have been proposed for the cleavage catalyzed by less basic buffers ($\text{p}K_{\text{a}} \approx 7$) that expectedly offer a more relevant model for enzyme action. Some of these mechanisms are summarized in Scheme 1A.

Several of these mechanisms share common features, *viz.* a rapid initial formation of a monoanionic phosphorane, followed by rate-limiting proton transfer to the departing 5′-oxygen atom. The first step, *i.e.* the pre-equilibrium formation of a monoanionic phosphorane intermediate upon attack of the neighboring 2′-OH on the phosphorus atom of the scissile phosphodiester linkage, has been proposed to involve concerted proton transfer from the attacking nucleophile to a non-bridging oxygen of the developing phosphorane intermediate.¹⁰⁻¹² In the absence of an appropriate general acid/base catalyst to allow the proton shuttling, the proton transfer is probably mediated by a water molecule (Scheme 1A, Route A),^{13, 14} whereas in the presence of one this role might be played by the catalyst, as proposed for guanidinium-derived RNA cleaving agents (Scheme 1A, route B).^{5, 6, 15, 16} In addition, a combination of rapid initial protonation of the phosphodiester linkage followed by general base-catalyzed attack of the 2′-OH (Scheme 1A, Route C) has also been suggested.⁷

The breakdown of the monoanionic phosphorane intermediate *via* rate-limiting fission of the P-O5′ bond has been proposed to be facilitated by proton transfer from a general acid either directly (Scheme 1A, Route D)⁹ or after deprotonation to a dianionic phosphorane (Scheme 1A, Route G).⁷ It should be noted, however, that a dianionic phosphorane is readily decomposed even without general acid catalysis by expulsion of an alkoxide leaving group.¹⁷ The pH- and buffer-independent cleavage of RNA phosphodiester linkages most likely takes place with concerted water-mediated proton transfer from a non-bridging oxygen to the leaving group (Scheme 1A, Route E)¹⁰⁻¹⁴ and a similar mechanism would seem feasible also in the case of the general acid/base catalyzed reaction, with the catalyst (rather than a water molecule) serving as the proton shuttle (Scheme 1A, Route F).^{5, 15, 16}

Recently, we demonstrated an approach to circumvent the problem of the weak buffer catalysis by anchoring the catalytic group close to the scissile phosphodiester linkage.¹⁸ As previously described for a Zn^{II}:1,5,9-triazacyclododecane-based cleaving agent,¹⁹ the high affinity of the Zn^{II}:cyclen chelate for uracil (and thymine)²⁰⁻²² was harnessed to bring a potential general acid/base catalyst, a substituted 1,3,5-triazine, near the phosphodiester bond of uridylyl-3′,5′-uridine (UpU) (Fig. 1A). In such assemblies, the N3 of uridine coordinates to the Zn^{II} ion with concomitant deprotonation and two of the aza functions of the cyclen ring donate hydrogen bonds to the oxo substituents of the uracil ring, leading to formation of a remarkably strong ternary complex at pH > 7.²² Around neutral pH, the desired complex predominated and the hydrolysis of UpU was accelerated by up to two orders of magnitude. The acceleration was found to be largely independent on the basicity of the triazine, consistent with a mechanism where the catalyst serves as a proton shuttle, mediating proton transfer from the attacking nucleophile to a non-bridging phosphoryl oxygen and, finally, to

Cite this: DOI: 10.1039/c0xx00000x

www.rsc.org/xxxxxx

ARTICLE TYPE

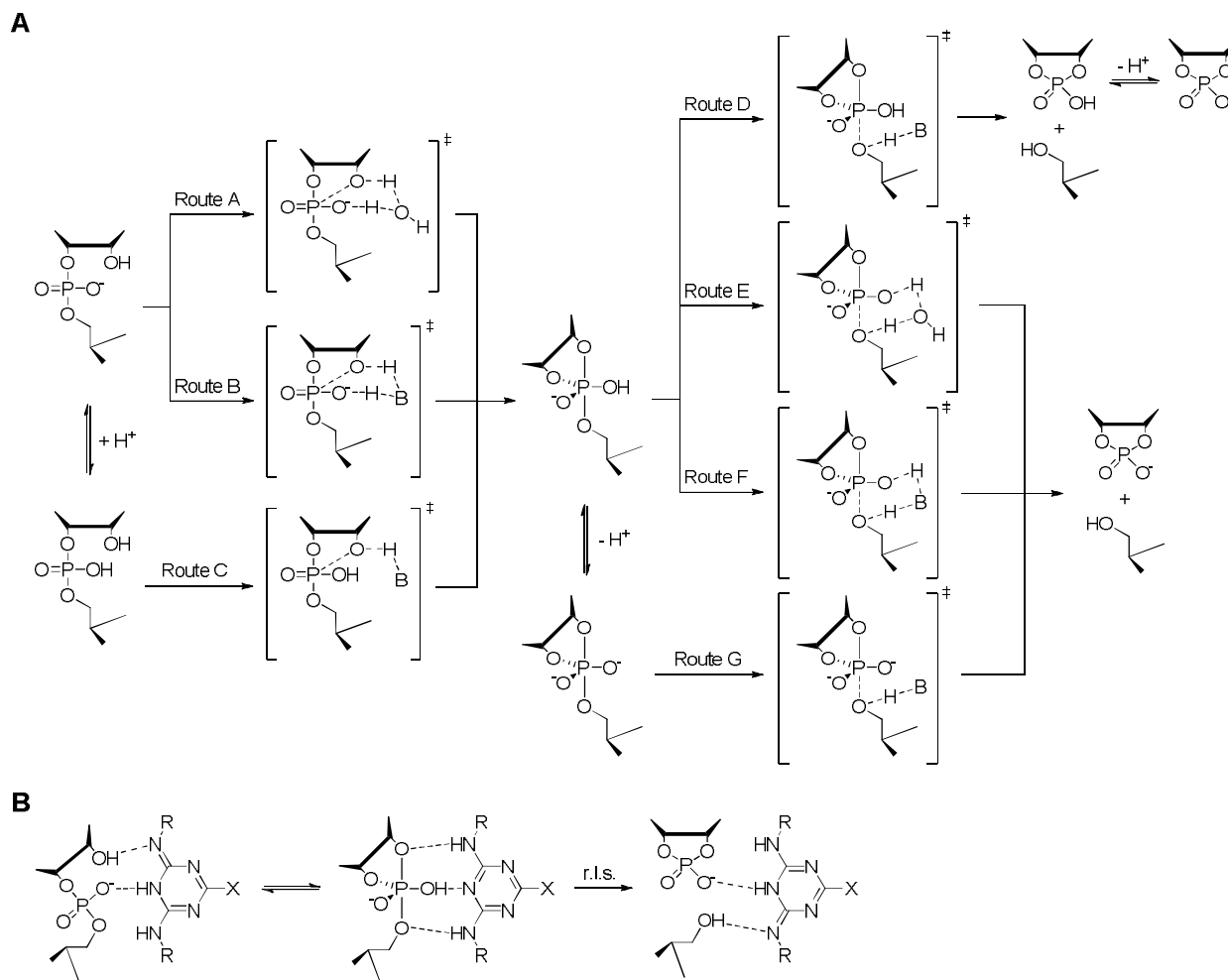

Scheme 1 Proposed mechanisms for RNA cleavage catalyzed by general acids and bases.

the leaving group (Scheme 1B).¹⁸

Of the three pathways proposed, cleavage *via* routes D and F should exhibit a leaving group effect similar to the one previously reported for the pH- and buffer-independent reaction (Scheme 1A, Route E), *viz.* $\beta_{lg} = -0.59$.¹¹ The β_{lg} value for route G, on the other hand, is difficult to predict with any reasonable accuracy. Evidently, increasing electronegativity of the leaving group exerts opposite effects on the protonation of the non-bringing oxygen and nucleophilic attack on phosphorus, leaving the effect on the formation of the monoanionic phosphorane modest. The pre-equilibrium deprotonation of the monoanionic phosphorane (pK_a 13.5 – 14.3)^{23, 24} and the breakdown of the dianionic intermediate are both favored by electron-withdrawing leaving groups. In other words, the rate of cleavage *via* route G is possibly more susceptible to the acidity of the leaving group than routes D, E or F. To find out whether the β_{lg} value referring to cleavage by triazine-based cleaving agents really is similar to that of route E, a number of alkyl esters of uridine-3'-phosphate have been

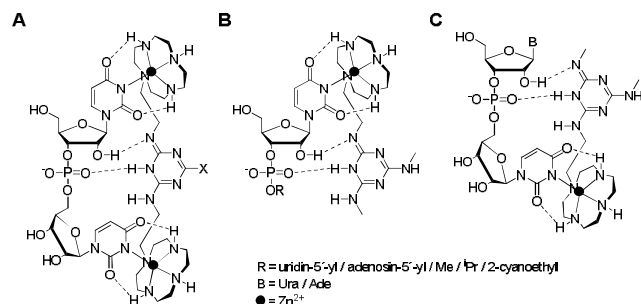
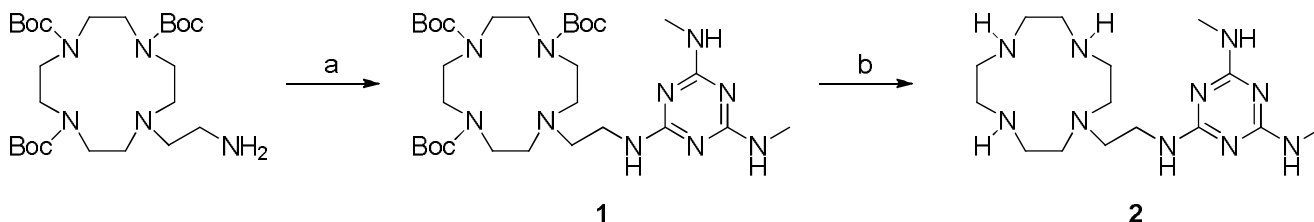

Fig. 1 Complexes of N3-deprotonated uridine-3'- and -5'-phosphates with mono- and binuclear Zn^{II} chelates of cyclen linked to a catalytic triazine moiety. In all cases, the geometry around the zinc nucleus is square pyramidal, with the uracil N3 forming the apex and the four nitrogen atoms of cyclen the basal plane of the pyramid. Note that the Zn^{II} ion is not coplanar with the cyclen nitrogens but lies between the cyclen ring and the uracil N3.

Cite this: DOI: 10.1039/c0xx00000x

www.rsc.org/xxxxxx

ARTICLE TYPE



Scheme 2 Preparation of the cleaving agent. *Reagents and conditions:* (a) 1. cyanuric chloride, DIPEA, MeCN, 2. methylamine, EtOH, MeCN, (b) 1. TFA, CH₂Cl₂, MeOH, 2. Dowex 1x2 (OH).

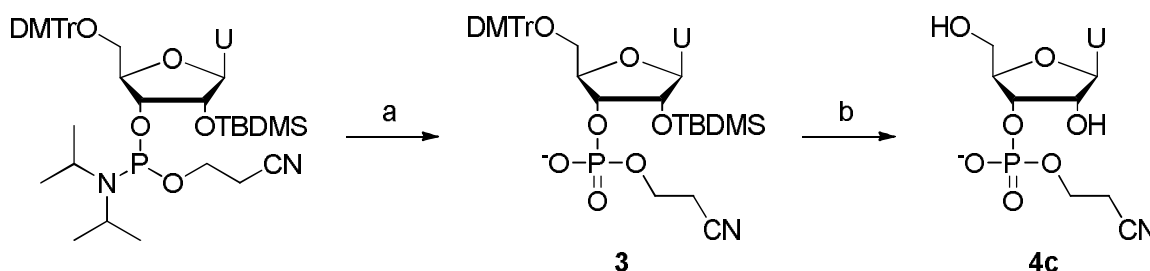

Scheme 3 Preparation of the alkyl esters of uridine-3'-phosphate. *Reagents and conditions:* (a) 1. H₂O, 4,5-dicyanoimidazole, MeCN, 2. I₂, H₂O, pyridine, (b) 1. Et₃N·3HF, THF, 2. HCl, MeOH, CH₂Cl₂.

synthesized and their hydrolytic reactions studied at various catalyst concentrations of (Fig. 1B). To exclude the possibility of metal-ion catalysis by the uncomplexed Zn^{II}:cyclen moiety (note that the substrates only contain one uracil ring), a new “one-armed” version of the cleaving agent has been used for this purpose. In addition to the derivatives of uridine-3'-phosphate, the ability of this “one-armed” cleaving agent to catalyze the hydrolysis of a uridine-5'-phosphate derivative, adenylyl-3',5'-uridine (ApU) has also been tested (Fig. 1C).

Results and Discussion

Preparation of the cleaving agent

Synthesis of the triazine-based cleaving agent bearing a single chelating cyclen moiety is presented in Scheme 2. First, 2-aminoethyl-functionalized *N*⁴,*N*⁷,*N*¹⁰-tris(*tert*-butoxycarbonyl)cyclen was prepared as described previously.¹⁸ This product was then treated with 1.5 eq. of cyanuric chloride, followed by an excess of methylamine to yield the protected cleaving agent **1**. Finally, the Boc protections were removed and the product was converted to the free amine by passing it through an OH-form strong anion exchange resin.

Preparation of the nucleoside diester models

Uridyl-3',5'-uridine (UpU), uridylyl-3',5'-adenosine (UpA), adenylyl-3',5'-uridine (ApU) and adenylyl-3',5'-adenosine (ApA) were commercial products that were used as received. Syntheses of the methyl and isopropyl esters of uridine-3'-phosphate (**4a** and **4b**, respectively) have been described in the

literature.^{17, 25} The 2-cyanoethyl ester of uridine-3'-phosphate (**4c**) was synthesized by DCI-promoted hydrolysis of commercially available 5'-*O*-(4,4'-dimethoxytrityl)-2'-*O*-(*tert*-butyldimethylsilyl)]phosphorimidite, after which the H-phosphonate intermediate was oxidized to the respective phosphate (Scheme 3). Finally, the *tert*-butyldimethylsilyl and 4,4'-dimethoxytrityl protections were removed with triethylamine trihydrofluoride and hydrogen chloride, respectively.

Cleavage studies on the dinucleoside monophosphate substrates

The ability of the Zn^{II} complex of the new “one-armed” cleaving agent **2** to catalyze the hydrolysis of an RNA phosphodiester linkage was first tested with four dinucleoside monophosphate targets, *viz.* UpU, UpA, ApU and ApA. The concentration of Zn^{II}:**2** was varied between 0 and 300 μmol L⁻¹, the concentration of the substrate being 5.0 μmol L⁻¹ (*T* = 90 °C, pH = 7.42). The reactions were followed by analyzing the composition of the aliquots withdrawn from the reaction mixture at appropriate time intervals by RP HPLC and the products were identified by spiking with authentic samples. Over the entire range of conditions used, only the expected products of RNA hydrolysis, *viz.* the 5'-linked nucleoside, the 2'- and 3'-monophosphates of the 3'-linked nucleoside and the 2',5'-isomer of the starting material, were detected (Scheme 4). The plots of the observed pseudo first-order rate constants for the cleavage of UpU, UpA, ApU and ApA as a function of [Zn^{II}:**2**] are presented in Fig. 2.

The cleavage rates of UpU and UpA are clearly dependent on

Cite this: DOI: 10.1039/c0xx00000x

www.rsc.org/xxxxxx

ARTICLE TYPE

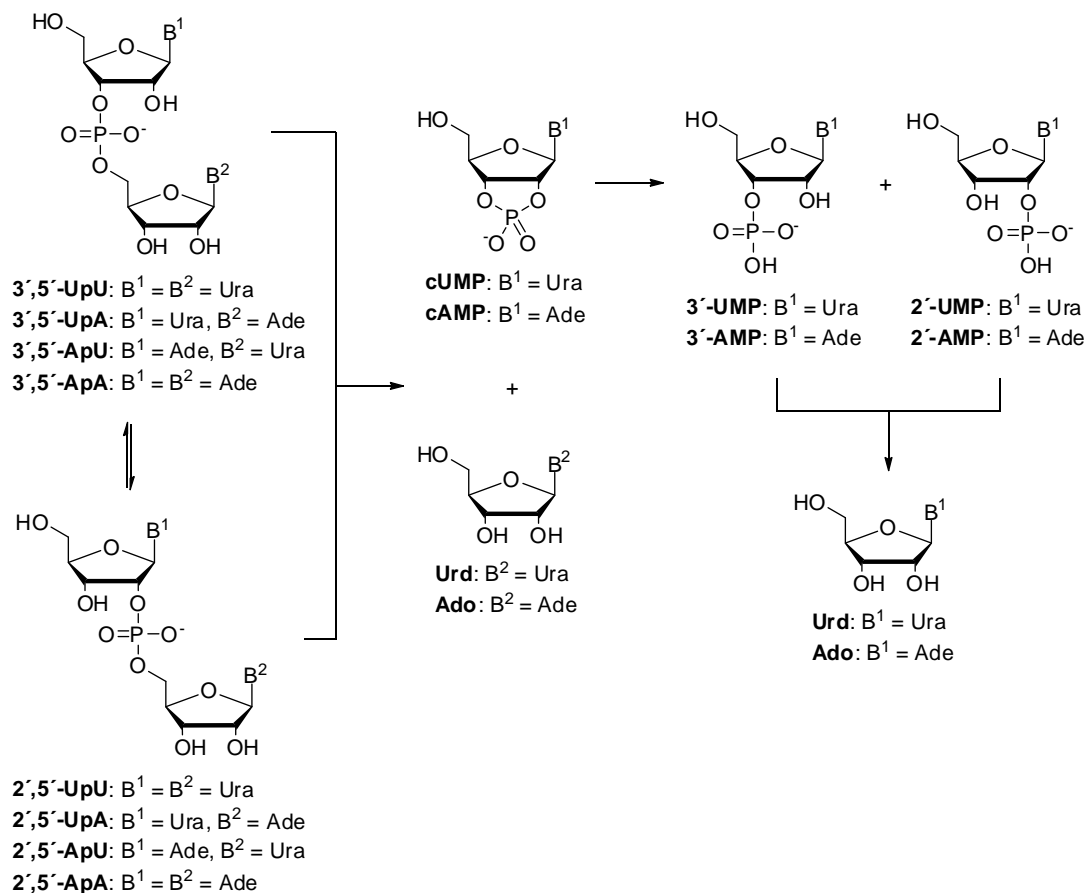

Scheme 4 Hydrolytic reaction pathways of UpU, UpA, ApU and ApA.

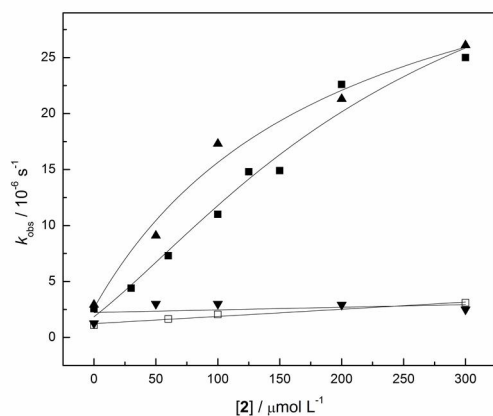
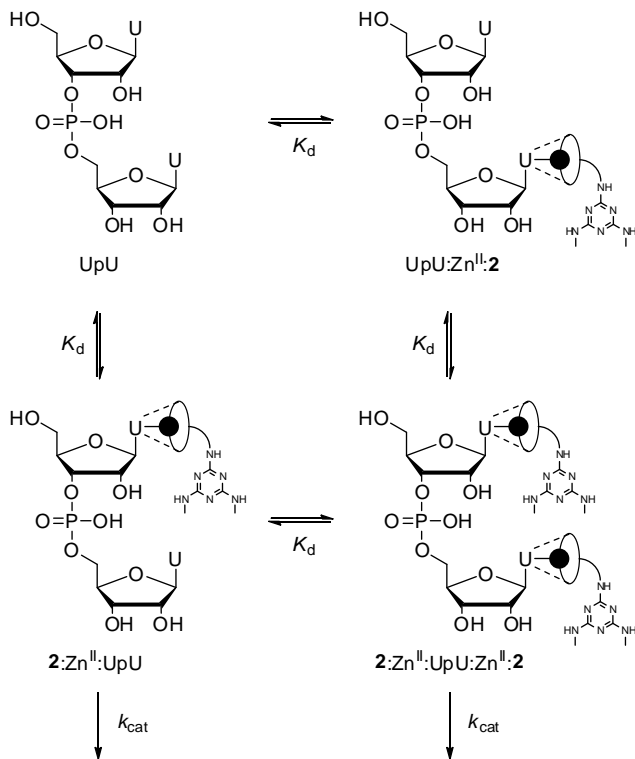

Fig. 2 Pseudo first-order rate constants for the cleavage of UpU (■), UpA (▲), ApU (▼) and ApA (□) as a function of the concentration of the Zn^{II} complex of the cleaving agent **2** at 90 °C, pH = 7.42, *I*(NaClO₄) = 0.10 mol L⁻¹, [UpU] = [UpA] = [ApU] = [ApA] = 5.0 μmol L⁻¹.

the concentration of Zn^{II}:**2**, but in a different way: the latter follows simple first-order kinetics (eqn. 1), whereas the former exhibits a more complicated dependence. In both cases, however, the apparent dissociation constant is very similar, log *K*_d = -3.7 and -3.6 for UpA and UpU, respectively. As could be expected, the mononuclear cleaving agent forms complexes somewhat less stable than the respective binuclear ones studied previously.¹⁸

$$k_{obs} = k_{uncat} + k_{cat} \frac{[2]}{K_d + [2]} \quad (1)$$

In contrast to UpU and UpA, the cleavage of ApU and ApA is hardly accelerated by Zn^{II}:**2**. In the case of ApA, the result is expected: with no uracil moiety to form the ternary complex with Zn^{II} and cyclen, the local concentration of the cleaving agent in the vicinity of the scissile phosphodiester linkage remains too low for efficient catalysis. The inability of Zn^{II}:**2** to cleave ApU is somewhat more surprising, but nevertheless understandable: the spatial relation of the uracil moiety to the scissile phosphodiester linkage is different in ApU and UpA and, apparently, coordination of the Zn^{II}:cyclen anchoring group to the 3'-linked nucleoside is



Scheme 5 Complexation equilibria and reactive complexes of UpU and $Zn^{II}:2$.

needed for catalysis. In particular, the requirement for binding of the cleaving agent to the 3'-linked nucleoside suggests a crucial interaction with the attacking 2'-oxygen, the reaction component most distant from the 5'-linked nucleoside.

The different reactivity of ApU and UpA also offers an explanation for the observed dependence of the rate of UpU cleavage on $[Zn^{II}:2]$. At non-saturating concentrations of $Zn^{II}:2$, UpU exists as an equilibrium mixture of four different species, *viz.* free UpU, two 1:1 complexes of UpU and $Zn^{II}:2$ ($2:Zn^{II}:UpU$ and $UpU:Zn^{II}:2$) and a 1:2 complex of UpU and $Zn^{II}:2$ ($2:Zn^{II}:UpU:Zn^{II}:2$) (Scheme 5). For reasons discussed above, only the 1:2 complex and one of the 1:1 complexes (the one in which the cleaving agent is bound to the 3'-linked uridine) are susceptible to general acid/base catalyzed cleavage of the phosphodiester linkage. Assuming that both of these reactive complexes react at the same rate and that both of the uracil bases of UpU form an equally stable complex with $Zn^{II}:2$, the observed rate constant for the cleavage of UpU as a function of $[Zn^{II}:2]$ may be expressed by eqn. 2.

$$k_{obs} = k_{uncat} + k_{cat} \frac{\frac{1}{2}K_d[2] + [2]^2}{K_d^2 + K_d[2] + [2]^2} \quad (2)$$

The observed base selectivity of $Zn^{II}:2$, *i.e.* the fact that it hardly promotes the cleavage of ApA or ApU, may be taken as evidence for general acid/base, rather than metal ion, catalysis. If the Zn^{II} ion (or its hydroxo ligand) was the catalytically active component, it would be expected to be interacting with the phosphodiester linkage, rather than the base moieties and, hence, exhibit similar efficiency towards all of the dinucleoside monophosphates studied. It is worth noting that Zn^{2+} promoted cleavage does not show any marked selectivity towards the

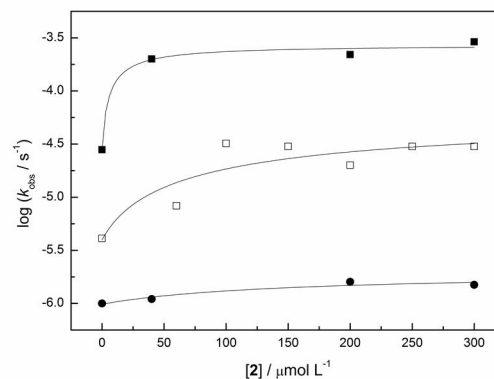

Fig. 3 Logarithmic pseudo first-order rate constants for the cleavage of **4a** (\square), **4b** (\bullet) and **4c** (\blacksquare) as a function of the concentration of the Zn^{II} complex of the cleaving agent **2** at 90 °C, pH = 7.42, $I(\text{NaClO}_4) = 0.10 \text{ mol L}^{-1}$, $[4a] = [4b] = [4c] = 5.0 \mu\text{mol L}^{-1}$.

identity of the base moieties.^{26, 27} Furthermore, even though the cleavage of UpU is catalyzed by $Zn^{II}:\text{cyclen}$, this catalysis is negligible under the conditions used in this study ($[Zn^{II}:2] < 300 \mu\text{mol L}^{-1}$), becoming significant only at much higher $Zn^{II}:\text{cyclen}$ concentrations.²⁸ For example, the rate constant for the $Zn^{II}:\text{cyclen}$ catalyzed cleavage of UpU at 90 °C, pH 6.2 and 2 mmol L^{-1} catalyst concentration is $2.4 \times 10^{-6} \text{ s}^{-1}$, an order of magnitude lower than obtained at 0.2 mmol L^{-1} concentration of $Zn^{II}:2$ under the same conditions (note that cleavage of UpU by triazine-based agents such as $Zn^{II}:2$ is pH-independent between pH 6 and 8).^{18, 28} In line with the results previously reported for the respective binuclear cleaving agents, phosphate migration between the 3'- and 2'-positions is neither facilitated nor retarded by $Zn^{II}:2$ in any of the systems studied.

Dependence of rate on the pK_a of the leaving group

The finding that coordination of the anchoring moiety of the cleaving agent to the 3'-linked uridine alone is sufficient for efficient catalysis allows one to study the influence of the leaving group on the rate of this reaction. In other words, the 5'-linked nucleoside may be replaced by a number of alcohols covering a wide range of pK_a values, resulting in model compounds **4a-c**. The hydrolysis of these substrates was studied by RP HPLC under the same conditions as the dinucleoside monophosphates, *i.e.* $5.0 \mu\text{mol L}^{-1}$ substrate, 0 – 300 $\mu\text{mol L}^{-1}$ cleaving agent, pH = 7.42 and $T = 90 \text{ }^\circ\text{C}$. The observed logarithmic pseudo first-order rate constants for the cleavage of **4a**, **4b** and **4c** as a function of $[Zn^{II}:2]$ are presented in Fig. 3.

As expected, the cleavage rates of all the model compounds studied exhibit a similar first-order dependence on the catalyst concentration as observed with UpA (eqn. 1). The logarithmic pseudo first-order rate constants for the uncatalyzed and catalyzed cleavage of **4a**, **4b**, **4c** and UpA, pK_a values of the respective leaving groups and dissociation constants for each of the reactive complexes, obtained by a non-linear least-squares fitting to eqn. 1, are presented in table 1.

The logarithmic pseudo first-order rate constants for the cleavage of **4a**, **4b**, **4c** and UpA by the Zn^{II} complex of **2** as a function of the pK_a value of the leaving group^{29, 30} are presented in figure 4. The cleavage rate exhibits a fairly good linear

Cite this: DOI: 10.1039/c0xx00000x

www.rsc.org/xxxxxx

ARTICLE TYPE

Table 1 Pseudo first-order rate constants for the uncatalyzed and catalyzed cleavage of **4a**, **4b**, **4c** and UpA, pK_a values of the respective leaving groups and dissociation constants for each of the reactive complexes; $T = 90\text{ }^\circ\text{C}$, $\text{pH} = 7.42$, $I(\text{NaClO}_4) = 0.10\text{ mol L}^{-1}$, $\mathbf{4a} = \mathbf{4b} = \mathbf{4c} = \text{UpA} = 5.0\text{ }\mu\text{mol L}^{-1}$.

Leaving group	$pK_a(\text{lg})$	$\log(k_{\text{uncat}}/\text{s}^{-1})$	$\log(k_{\text{cat}}/\text{s}^{-1})$	$\log K_d$
2-cyanoethanol (4c)	14.03 ^a	-4.6 ± 0.1	-3.6 ± 0.1	-4.8 ± 0.4
Ado-5'-OH (UpA)	14.5 ^b	-5.6 ± 0.2	-4.4 ± 0.1	-3.7 ± 0.3
methanol (4a)	15.5 ^a	-5.4 ± 0.2	-4.3 ± 0.4	-3.6 ± 0.5
isopropanol (4b)	17.1 ^a	-6.0 ± 0.1	-6.0 ± 0.3	-3.7 ± 0.5

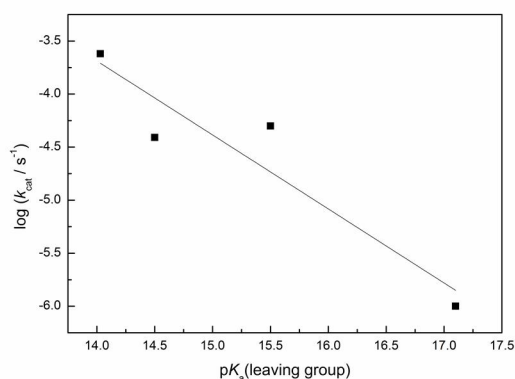
^a From ref. 29.^b For an approximation of the pK_a value of the 5'-OH of adenosine, see ref. 30.**Fig. 4** Logarithmic pseudo first-order rate constants for the cleavage of **4a**, **4b**, **4c** and UpA by the Zn^{II} complex of **2** as a function of the pK_a value of the leaving group; $T = 90\text{ }^\circ\text{C}$, $\text{pH} = 7.42$, $I(\text{NaClO}_4) = 0.10\text{ mol L}^{-1}$.

F). In all likelihood, both proton transfers are mediated by the general acid/base catalyst, *i.e.* the substituted triazine ring.

Conclusions

A triazine-based general acid/base-catalyst functionalized with a single Zn^{II} -cyclen anchoring moiety is able to cleave internucleosidic phosphodiester bonds but only when the 3'-linked nucleoside is uridine, consistent with deprotonation of the attacking 2'-OH by the triazine moiety. The dependence of the rate of this catalyzed reaction on the pK_a value of the leaving group is very similar to the one previously reported for the pH- and buffer-independent cleavage of RNA phosphodiester linkages, interpreted to involve two water-mediated proton transfers, the latter one taking place concerted with rate-limiting P-O bond fission. While not strictly excluding all other possibilities, the present results are consistent with the idea that general acid/base-catalyzed RNA cleavage proceeds by a similar mechanism, *i.e.* pre-equilibrium deprotonation of the attacking 2'-OH and formation of a monoanionic phosphorane intermediate followed by proton transfer from the intermediate to the departing 5'-oxygen concerted with rate-limiting cleavage of the P-O5' bond. Proper orientation and pK_a values of the general acid and base catalysts makes this proton-shuttling much more efficient than would be possible by merely a network of water molecules.

Experimental

General

The NMR spectra were recorded on a Bruker Avance 400 or 500 instrument and the mass spectra on a Bruker MicroTOF-Q instrument. The nucleoside phosphoramidites and dinucleoside monophosphates were commercial products and were used as received. The solvents and buffer constituents were of reagent grade.

Kinetic measurements

Reactions were carried out in sealed tubes immersed in a thermostated water bath, the temperature of which was adjusted to $90\text{ }^\circ\text{C}$ within $\pm 0.1\text{ }^\circ\text{C}$. The hydronium ion concentration of the reaction solutions was adjusted to 7.42 with a HEPES buffer and

dependence on the acidity of the leaving group, the slope being $\beta_{\text{lg}} = -0.7 \pm 0.2$. For comparison, the β_{lg} values previously reported for the hydronium ion catalyzed, the pH- and buffer-independent and the hydroxide ion catalyzed cleavage of RNA phosphodiester bonds are -0.12 ,¹⁷ -0.59 ¹¹ and -1.28 ,¹⁷ respectively.³¹ The first value is characteristic of a mechanism where the leaving group departs as an alcohol and the third one of a mechanism where the leaving group departs as an alkoxide ion.¹⁷ The second value, on the other hand, has been interpreted to indicate a water-mediated proton transfer to the departing oxygen taking place concerted with the rate-limiting P-O5' bond fission.¹¹ The present β_{lg} value for the general acid/base catalyzed cleavage of RNA phosphodiester bonds lies close to the one previously reported for the pH- and buffer-independent reaction and, hence, suggests a similar mechanism. In other words, the reaction probably involves pre-equilibrium deprotonation of the attacking 2'-OH and formation of a monoanionic phosphorane intermediate (Scheme 1A, Route B) and rate-limiting proton transfer from the intermediate to the departing 5'-oxygen concerted with cleavage of the P-O5' bond (Scheme 1A, Route

the ionic strength to 0.10 mol L⁻¹ with NaClO₄. The initial substrate concentration of the reactions was 5.0 μmol L⁻¹ and the catalyst concentration 0 – 300 μmol L⁻¹. The composition of the samples withdrawn from the reaction solutions at appropriate time intervals was analyzed by RP HPLC on a Hypersil-Keystone Aquasil C18 column (4 × 150 mm, 5 μm), the flow rate being 1.0 mL min⁻¹. For the reactions of UpU, UpA, ApU and ApA, a mixture of 60 mmol L⁻¹ acetate buffer (pH = 4.3) and MeOH was used as an eluent. For the first 10 min, neat buffer was used, after which the MeOH content was increased linearly to 30% during 5 min and kept there for another 5 min. The observed retention times (*t_R*, min) for the hydrolytic products of UpU, UpA, ApU and ApA were as follows: 19.0 (3',5'-ApA), 17.5 (3',5'-ApU), 17.2 (2',5'-ApA, Ado), 16.8 (3',5'-UpA), 16.0 (3',5'-UpU), 15.9 (2',5'-ApU, 2',5'-UpA), 15.3 (2',5'-UpU), 6.5 (Urd), 5.2 (2'-UMP), 4.6 (3'-UMP), 4.4 (2'-AMP), 4.0 (3'-AMP), 3.8 (2',3'-cUMP). For the reactions of the alkyl esters of uridine-3'-phosphate (**4a-c**), MeCN was used instead of MeOH as the organic component of the eluent. For the first 5 min, neat buffer was used, after which the MeCN content was increased linearly to 20% during 5 min and kept there for another 10 min. The observed retention times (*t_R*, min) for the hydrolytic products of **4a-c** were as follows: 13.5 (**4b**), 13.0 (**4c**), 9.2 (**4a**), 6.3 (Urd), 5.2 (2'-UMP), 4.6 (3'-UMP), 3.8 (2',3'-cUMP). In all cases, the products were characterized by spiking with authentic samples. Pseudo first-order rate constants for the disappearance of the substrate were obtained by applying the first-order rate law to the time-dependent diminution of the relative peak area of the substrate.

***N*²-[2-(*N*⁴,*N*⁷,*N*¹⁰-tri-*tert*-butoxycarbonyl-1,4,7,10-tetraazacyclododecan-1-yl)ethyl]-*N*⁴,*N*⁶-dimethylmelamine (**1**)**

1,4,7-Tris(*tert*)butoxycarbonyl-10-(2-aminoethyl)cyclen⁹ (0.516 g, 1.00 mmol) was dissolved in MeCN (5.0 mL) and the resulting solution was added drop-wise at 0 °C to a stirred solution of cyanuric chloride (0.277 g, 1.50 mmol) and DIPEA (0.348 mL, 2.00 mmol) in MeCN (10.0 mL). After being stirred for 1 h at room temperature, the reaction mixture was allowed to warm to room temperature and 33% ethanolic methylamine (11.0 mL) was added. Stirring at room temperature was continued for 96 h, after which the reaction mixture was evaporated to dryness. The residue was purified on a silica gel column eluting with a mixture of Et₃N, MeOH and CH₂Cl₂ (1:4:95, v/v). Yield 0.287 g (44%). ¹H NMR (δ_H)(500 MHz, CDCl₃): 3.50-3.10 (m, 14H), 2.75 (br, 6H), 2.57 (br, 6H), 1.34 (br, 9H), 1.33 (br, 18H). ¹³C NMR (δ_C)(125 MHz, CDCl₃): 166.5, 165.8, 156.1, 155.7, 155.2, 79.5, 79.4, 79.1, 53.4, 46.0, 28.6, 28.4, 27.4. HRMS (ESI⁺): *m/z* calcd 653.4457 obsd 653.4783.

***N*²-[2-(1,4,7,10-tetraazacyclododecan-1-yl)ethyl]-*N*⁴,*N*⁶-dimethylmelamine (**2**)**

Compound **1** (0.287 g, 0.440 mmol) was dissolved in a mixture of TFA (2.5 mL), CH₂Cl₂ (2.0 mL) and MeOH (0.5 mL). The resulting solution was stirred at room temperature for 5 h, after which it was evaporated to dryness. The residue was passed through Dowex 1x2 (OH⁻) resin to afford the product as a free amine. Yield 0.136 g (87%). ¹H NMR (δ_H)(500 MHz, D₂O): 3.24 (br, 2H), 2.70 (br, 6H), 2.64-2.28 (m, 18H). ¹³C NMR (δ_C)(125 MHz, D₂O): 165.2, 53.4, 51.0, 44.9, 44.4, 43.3, 38.5, 27.0.

HRMS (ESI⁺): *m/z* calcd 353.2884 obsd 353.2890.

Uridine-3'-[(2-cyanoethyl)phosphate (4c**)**

5'-*O*-(4,4'-dimethoxytrityl)-2'-*O*-(*tert*-butyldimethylsilyl)uridine 3'-[(2-cyanoethyl)-(N,N-diisopropyl)]phosphoramidite (500 mg, 0.581 mmol) was dissolved in a mixture of water (1.0 mL) and 0.25 mol L⁻¹ solution of 4,5-dicyanoimidazole in MeCN (4.645 mL). The reaction mixture was stirred at room temperature for 15 min, after which 0.1 mol L⁻¹ solution of iodine in pyridine (9.0 mL) was added. After being stirred for another 15 min at room temperature, the reaction mixture was diluted with CH₂Cl₂ (100 mL) and washed with 5% aq. NaHSO₃ (100 mL). The aqueous phase was back extracted with CH₂Cl₂ (100 mL), the combined organic phases dried with Na₂SO₄ and evaporated to dryness. The residue was dissolved in THF (10.0 mL) and triethylamine trihydrofluoride (0.758 mL, 4.65 mmol) was added and the resulting mixture stirred at room temperature for 48 h, after which it was diluted with CH₂Cl₂ (100 mL) and washed with saturated aq. NaHCO₃ (100 mL). The aqueous phase was back extracted with CH₂Cl₂ (100 mL) and the combined organic phases dried with Na₂SO₄ and evaporated to dryness. The residue was dissolved in CH₂Cl₂ (20 mL) and 1.25 M HCl in MeOH (1.0 mL) was added. The white precipitate formed was collected by filtration and washed with hexane to afford the product as a sodium salt. Yield 16.4 mg (7%). ¹H NMR (δ_H)(400 MHz, D₂O): 7.80 (d, 1H, *J* = 8.1 Hz), 5.89 (d, 1H, *J* = 5.4 Hz), 5.82 (d, 1H, *J* = 8.1 Hz), 4.52 (ddd, 1H, *J*₁ = 4.9 Hz, *J*₂ = 5.0 Hz, *J*₃ = 8.1 Hz), 4.39 (dd, 1H, *J*₁ = *J*₂ = 5.4 Hz), 4.25 (ddd, 1H, *J*₁ = 3.2 Hz, *J*₂ = 4.0 Hz, *J*₃ = 4.2 Hz), 4.05 (ddd, 1H, *J*₁ = 1.8 Hz, *J*₂ = 2.2 Hz, *J*₃ = 6.3 Hz), 4.02 (ddd, 1H, *J*₁ = 1.2 Hz, *J*₂ = 1.7 Hz, *J*₃ = 5.8 Hz), 3.83 (dd, 1H, *J*₁ = 2.8 Hz, *J*₂ = 12.9 Hz), 3.75 (dd, 1H, *J*₁ = 4.2 Hz, *J*₂ = 12.9 Hz), 2.78 (dd, 2H, *J*₁ = 5.8 Hz, *J*₂ = 5.9 Hz). ¹³C NMR (δ_C)(100 MHz, D₂O): 166.2, 151.7, 141.8, 119.4, 102.5, 88.8, 83.8, 73.5, 72.8, 60.7, 60.6, 19.4. ³¹P NMR (δ_P)(162 MHz, D₂O): -0.70. HRMS (ESI⁺): *m/z* calcd 376.0551 obsd 376.0587.

Acknowledgements

We thank professor Harri Lönnberg for fruitful discussions.

Notes and references

- ^a Department of Chemistry, University of Turku, FIN-20014, Turku, Finland. Fax: +358 2 333 6700; Tel: +358 2 333 6777; E-mail: tuanol@utu.fi
- † Electronic Supplementary Information (ESI) available: ¹H and ¹³C NMR spectra of compounds **1**, **2** and **4c**, ³¹P NMR spectrum of compound **4c**, UV spectra of compounds **2** and **4c** and HPLC chromatogram of compound **2**. See DOI: 10.1039/b000000x/
- 1 S. A. Strobel, *Nat. Chem. Biol.*, 2005, **1**, 5.
- 2 P. C. Bevilacqua and R. Yajima, *Curr. Opin. Chem. Biol.*, 2006, **10**, 455.
- 3 A. Fersht, *Enzyme Structure and Mechanism*, W. H. Freeman and Co., New York, 1985.
- 4 D. M. Perreault and E. V. Anslyn, *Angew. Chem. Int. Ed.*, 1997, **36**, 432.
- 5 H. Lönnberg, in *Ribonucleases*, ed. A. W. Nicholson, Springer-Verlag Berlin, Berlin, 2011, vol. 26, pp. 343.
- 6 H. Lönnberg, *Org. Biomol. Chem.*, 2011, **9**, 1687.
- 7 R. Breslow, S. D. Dong, Y. Webb and R. Xu, *J. Am. Chem. Soc.*, 1996, **118**, 6588.
- 8 A. J. Kirby and R. E. Marriott, *J. Chem. Soc., Perkin Trans. 2*, 2002, 422.

-
- 9 C. Beckmann, A. J. Kirby, S. Kuusela and D. C. Tickle, *J. Chem. Soc., Perkin Trans. 2*, 1998, 573.
- 10 M. Kosonen, R. Seppänen, O. Wichmann and H. Lönnberg, *J. Chem. Soc., Perkin Trans. 2*, 1999, 2433.
- 5 11 M. Kosonen, E. Yousefi-Salakdeh, R. Strömberg and H. Lönnberg, *J. Chem. Soc., Perkin Trans. 2*, 1998, 1589.
- 12 X. Lopez, A. Dejaegere, F. Leclerc, D. M. York and M. Karplus, *J. Phys. Chem. B*, 2006, **110**, 11525.
- 13 M. Boero, K. Terakura and M. Tateno, *J. Am. Chem. Soc.*, 2002, **124**, 8949.
- 10 14 B. Gerratana, G. A. Sowa and W. W. Cleland, *J. Am. Chem. Soc.*, 2000, **122**, 12615.
- 15 U. Scheffer, A. Strick, V. Ludwig, S. Peter, E. Kalden and M. W. Göbel, *J. Am. Chem. Soc.*, 2005, **127**, 2211.
- 15 16 A. M. Piątek, M. Gray and E. V. Anslyn, *J. Am. Chem. Soc.*, 2004, **126**, 9878.
- 17 M. Kosonen, E. Youseti-Salakdeh, R. Strömberg and H. Lönnberg, *J. Chem. Soc., Perkin Trans. 2*, 1997, 2661.
- 18 T. A. Lönnberg, M. Helkearo, A. Jancsó and T. Gajda, *Dalton Trans.*, 2012, **41**, 3328.
- 20 19 Q. Wang and H. Lönnberg, *J. Am. Chem. Soc.*, 2006, **128**, 10716.
- 20 S. Aoki and E. Kimura, *Chem. Rev.*, 2004, **104**, 769.
- 21 E. Kimura and T. Koike, *Chem. Comm.*, 1998, 1495.
- 22 M. Shionoya, E. Kimura and M. Shiro, *J. Am. Chem. Soc.*, 1993, **115**, 6730.
- 25 23 J. E. Davies, N. L. Doltsinis, A. J. Kirby, C. D. Roussev and M. Sprik, *J. Am. Chem. Soc.*, 2002, **124**, 6594.
- 24 X. Lopez, M. Schaefer, A. Dejaegere and M. Karplus, *J. Am. Chem. Soc.*, 2002, **124**, 5010.
- 30 25 H. Korhonen, S. Mikkola and N. H. Williams, *Chem. Eur. J.*, 2012, **18**, 659.
- 26 S. Kuusela and H. Lönnberg, *Nucleosides Nucleotides Nucleic Acids*, 1996, **15**, 1669.
- 27 J. J. Butzow and G. L. Eichhorn, *Biochemistry*, 1971, **10**, 2019.
- 35 28 S. Kuusela and H. Lönnberg, *J. Phys. Org. Chem.*, 1993, **6**, 347.
- 29 E. P. Serjeant and B. Dempsey, *Ionisation constants of organic acids in aqueous solution*, Pergamon Press, Oxford, 1979.
- 30 T. Lönnberg and M. Laine, *Org. Biomol. Chem.*, 2010, **8**, 349.
- 31 H. Lönnberg, R. Strömberg and A. Williams, *Org. Biomol. Chem.*, 2004, **2**, 2165.
- 40