

University of Groningen

Variants in the GPR146 Gene Are Associated With a Favorable Cardiometabolic Risk Profile

Rimbert, Antoine; Yeung, Ming W; Dalila, Nawar; Thio, Chris H L; Yu, Haojie; Loaiza, Natalia; Oldoni, Federico; van der Graaf, Adriaan; Wang, Siqi; Said, M Abdullah

Published in:
Arteriosclerosis, thrombosis, and vascular biology

DOI:
[10.1161/ATVBAHA.122.317514](https://doi.org/10.1161/ATVBAHA.122.317514)

IMPORTANT NOTE: You are advised to consult the publisher's version (publisher's PDF) if you wish to cite from it. Please check the document version below.

Document Version
Publisher's PDF, also known as Version of record

Publication date:
2022

[Link to publication in University of Groningen/UMCG research database](#)

Citation for published version (APA):

Rimbert, A., Yeung, M. W., Dalila, N., Thio, C. H. L., Yu, H., Loaiza, N., Oldoni, F., van der Graaf, A., Wang, S., Said, M. A., Blauw, L. L., Girardeau, A., Bray, L., Caillaud, A., Bloks, V. W., Marrec, M., Mouli, P., Rensen, P. C. N., van de Sluis, B., ... Kuivenhoven, J. (2022). Variants in the GPR146 Gene Are Associated With a Favorable Cardiometabolic Risk Profile. *Arteriosclerosis, thrombosis, and vascular biology*, 42(10), 1262-1271. <https://doi.org/10.1161/ATVBAHA.122.317514>

Copyright

Other than for strictly personal use, it is not permitted to download or to forward/distribute the text or part of it without the consent of the author(s) and/or copyright holder(s), unless the work is under an open content license (like Creative Commons).

The publication may also be distributed here under the terms of Article 25fa of the Dutch Copyright Act, indicated by the "Taverne" license. More information can be found on the University of Groningen website: <https://www.rug.nl/library/open-access/self-archiving-pure/taverne-amendment>.

Take-down policy

If you believe that this document breaches copyright please contact us providing details, and we will remove access to the work immediately and investigate your claim.

Downloaded from the University of Groningen/UMCG research database (Pure): <http://www.rug.nl/research/portal>. For technical reasons the number of authors shown on this cover page is limited to 10 maximum.

ORIGINAL RESEARCH

Variants in the *GPR146* Gene Are Associated With a Favorable Cardiometabolic Risk Profile

Antoine Rimbart¹, Ming W. Yeung², Nawar Dalila, Chris H.L. Thio³, Haojie Yu⁴, Natalia Loaiza, Federico Oldoni⁵, Adriaan van der Graaf⁶, Siqi Wang⁷, M. Abdullah Said⁸, Lisanne L. Blauw, Aurore Girardeau, Lise Bray⁹, Amandine Caillaud¹⁰, Vincent W. Bloks, Marie Marrec, Philippe Mouli, Patrick C.N. Rensen¹¹, Bart van de Sluis¹², Harold Snieder¹³, Mathilde Di Filippo¹⁴, Pim van der Harst¹⁵, Anne Tybjaerg-Hansen, Philippe Zimmerman, Bertrand Cariou¹⁶, Jan Kuivenhoven¹⁷

BACKGROUND: In mice, *GPR146* (G-protein-coupled receptor 146) deficiency reduces plasma lipids and protects against atherosclerosis. Whether these findings translate to humans is unknown.

METHODS: Common and rare genetic variants in the *GPR146* gene locus were used as research instruments in the UK-Biobank, The Lifelines, and The Copenhagen-City Heart Study, and a cohort of individuals with familial hypobetalipoproteinemia were used to find and study rare *GPR146* variants.

RESULTS: In the UK-Biobank, carriers of the common rs2362529-C allele present with lower low-density lipoprotein cholesterol, apo (apolipoprotein) B, high-density lipoprotein cholesterol, apoA1, CRP (C-reactive protein), and plasma liver enzymes compared with noncarriers. Carriers of the common rs1997243-G allele, associated with higher *GPR146* expression, present with the exact opposite phenotype. The associations with plasma lipids of the above alleles are allele dose-dependent. Heterozygote carriers of a rare coding variant (p.Pro62Leu; n=2615), predicted to be damaging, show a stronger reductions in the above parameters compared with carriers of the common rs2362529-C allele. The p.Pro62Leu variant is furthermore shown to segregate with low low-density lipoprotein cholesterol in a family with familial hypobetalipoproteinemia. Compared with controls, carriers of the common rs2362529-C allele show a marginally reduced risk of coronary artery disease ($P=0.03$) concomitant with a small effect size on low-density lipoprotein cholesterol (average decrease of 2.24 mg/dL in homozygotes) of this variant. Finally, mendelian randomization analyses suggest a causal relationship between *GPR146* gene expression and plasma lipid and liver enzyme levels.

CONCLUSIONS: This study shows that carriers of new genetic *GPR146* variants have a beneficial cardiometabolic risk profile, but it remains to be shown whether genetic or pharmaceutical inhibition of *GPR146* protects against atherosclerosis in humans.

Key Words: allele ■ atherosclerosis ■ liver ■ mice ■ phenotype

In 2013, *GPR146*, encoding the G-protein-coupled receptor 146, was identified as a lipid gene through genome-wide association studies.¹ More specifically, a common DNA variation (rs1997243) in close proximity to the *GPR146* gene, present in 14% of individuals in the general population, was found to be associated with higher plasma levels of total cholesterol. Han et al² later showed that this increase in plasma cholesterol

is caused by higher levels of *GPR146* mRNA indicating that the encoded protein is directly involved in the regulation of cholesterol metabolism. Data in the public domain show that *GPR146* is mostly expressed in white adipose tissue where it has been reported to play a role in adipocyte differentiation,³ but this is unlikely to explain its effect on plasma cholesterol. In mice, we previously provided evidence that loss of *Gpr146* in the

Correspondence to: Antoine Rimbart, PhD, Université de Nantes, Institut du thorax, 8 Quai moncoussu, Nantes 44000, France. Email: antoine.rimbart@univ-nantes.fr
Supplemental Material is available at <https://www.ahajournals.org/doi/suppl/10.1161/ATVBAHA.122.317514>.

For Sources of Funding and Disclosures, see page XXX.

© 2022 The Authors. *Arteriosclerosis, Thrombosis, and Vascular Biology* is published on behalf of the American Heart Association, Inc., by Wolters Kluwer Health, Inc. This is an open access article under the terms of the [Creative Commons Attribution Non-Commercial](https://creativecommons.org/licenses/by-nc/4.0/) License, which permits use, distribution, and reproduction in any medium, provided that the original work is properly cited and is not used for commercial purposes.

Arterioscler Thromb Vasc Biol is available at www.ahajournals.org/journal/atvb

Nonstandard Abbreviations and Acronyms

apo	apolipoprotein
CAD	coronary artery disease
CRP	C-reactive protein
eQTL	expression quantitative trait loci
GPR146	G-protein–coupled receptor 146
HDL-C	high-density lipoprotein cholesterol
LDL-C	low-density lipoprotein cholesterol
SNP	single nucleotide polymorphism

liver reduces plasma cholesterol levels.⁴ Murine *Gpr146* deficiency was furthermore shown to decrease the hepatic secretion of VLDL, the precursor of LDL, and to protect against diet-induced atherosclerosis in LDL receptor knock-out mice. Considering that GPRs are druggable targets,⁵ the latter finding nourished hope for the development of small molecules to inhibit GPR146 (G-protein–coupled receptor 146) to improve the management of dyslipidemia and atherosclerosis, particularly in patients suffering from homozygous familial hypercholesterolemia, lacking the LDL receptor.^{6,7} The effects of GPR146 on plasma lipids in mice are associated with the fasting-refed state,⁴ but it is not known what the natural ligand for cellular GPR146 activation is. C-peptide, a cleavage product of insulin has been reported to play a role,⁸ but this was later disputed.⁹

Almost 10 years after its discovery, studies into the role of GPR146 in human metabolism are restricted to the association of a single variant which is associated with higher plasma lipids.¹ The current study investigates the associations of common and rare variants in *GPR146* genetic locus with opposite effects on plasma lipids levels. Using common variants as genetic instruments, we demonstrate the causal relationship between *GPR146* gene expression with plasma lipids and cardiometabolic traits. Effects on atherosclerosis were in line with changes with plasma lipids but did not reach statistical significance.

METHODS

The data that support the findings of this study are available from the corresponding author upon reasonable request.

Association Between Genetic Markers and *GPR146* Gene Expression

Expression quantitative trait loci (eQTL) analyses aim to connect genetic variants with the expression of genes, or specifically of nearby genes, in case of cis-eQTL. We studied the effects of rs2362529 and rs1997243 on *GPR146* expression in the human liver using the eQTL dataset from GTEx (V8 release, <https://www.gtportal.org/home/testyourown>).¹⁰ Additionally, we used the eQTL dataset from the eQTLGen consortium,¹¹

Highlights

- Lower *GPR146* gene expression is associated with beneficial effects on plasma: lipids, liver enzymes, and hsCRP, with a concordant reduction in coronary artery disease risk.
- THE *GPR146*-p.Pro62Leu coding rare variant induces larger reductions of plasma lipids, liver enzymes, and CRP (C-reactive protein) compared with the common variant.
- GPR146 (G-protein–coupled receptor 146) deficiency may be a new genetic cause of familial hypobetalipoproteinemia and a potential target for intervention to reduce plasma cholesterol levels and atherosclerosis with a particularly good metabolic safety profile.

the largest eQTL repository available to date ([Supplemental Material](#)). We tested the association of rs2362529 and rs1997243 with the expression of nearby genes including *GPR146* in blood.

Genetic Associations With Plasma Circulating Biomarkers in the UK Biobank

The UK Biobank study is a population-based prospective cohort in the United Kingdom in which ≈ 500 000 individuals aged between 40 and 69 years were recruited from 2006 through 2010. All participants have given informed consent for this study. The UK Biobank has ethical approval from North West–Haydock Research Ethics Committee (REC reference: 16/NW/0274). Details of the UK Biobank study have been described previously.¹² This research has been conducted using the UK Biobank resource under application number 15031. Clinical characteristics and biomarkers of individuals, variant genotyping, imputation and quality controls as well as genetic and statistical analyses are described in [Table S1](#) and [Figure S1](#).

Genetic Association With Coronary Artery Disease

Genetic association with coronary artery disease was assessed by using summary data from the meta-analysis published by Nikpay et al.¹³ (<http://www.cardiogramplusc4d.org/>). To test the relevance of these effects, we compared it with well-established low-density lipoprotein cholesterol (LDL-C) associated variants (as presented by Ference et al¹⁴ in the consensus statement from the European Atherosclerosis Society Consensus Panel) using data from van der Harst et al.¹⁵

Mendelian Randomization

We performed 2-sample Mendelian randomization (MR) analyses to assess potential causal effects of *GPR146* (*ENSG00000164849*) expression in blood on cardiometabolic outcomes using GWAS data publicly available via the OpenGWAS project repository (<https://gwas.mrcieu.ac.uk/>; [Table S2](#)). The 2 eQTLs (rs1997243 and rs2362529) were

used as genetic instruments. Alleles were harmonized between Wald ratios, calculated per single nucleotide polymorphism (SNP). We calculated SNP-specific Wald ratios (SNP-outcome effect divided by SNP-exposure effect). Then, a generalized weighted linear regression model was used to pool Wald ratios, which allows for correlation between SNPs (LD r^2 according to the 1000G EUR reference population). MR analyses were performed using the *MendelianRandomization* R Package (v0.6).¹⁶ From eQTLgen consortium summary data, we extracted all SNPs within a 100kb radius around the most significant eQTL for GPR146 expression. We then performed genetic colocalization analysis to calculate the posterior probability for the single shared causal variant hypothesis using the *coloc* R package¹⁷ using default, skeptical priors.

Selection of Individuals With Extreme LDL-C and Targeted Sequencing

Individuals with extreme dyslipidemia are likely to carry rare genetic variants (loss or gain of-function) in genes with large effects on lipid metabolism, and we set out to find such variants in *GPR146* in 2 large population-based prospective cohort studies: the Lifelines (n=167 729 individuals from the Netherlands^{18–20}) and the Copenhagen City Heart Study (CCHS n=20 000 individuals from Denmark^{21,22}). We selected unrelated individuals with extremely low LDL-C (n=222 from Lifelines and n=195 from CCHS, LDL-C <first and second percentiles, respectively) and extremely high LDL-C (n=129 from Lifelines and n=194 from CCHS, LDL-C >99th and 98th percentiles, respectively; [Tables S3 and S4](#)). The next generation sequencing platform and analysis workflow that were used are detailed in the [Supplemental Material](#).

The proband of a familial case with hypocholesterolemia (LDL-C <5th percentile for age and sex) was recruited in the context of the HYPOCHOL trial (REGISTRATION: URL: <https://www.clinicaltrials.gov>; Unique Identifier: NCT02354079). The genetic screening was performed using the DysliSEQ custom NGS panel as described previously.²³

Statistics and Plots

Statistical analyses and tools used for plotting are described in the [Supplemental Material](#).

RESULTS

Common Variants in the *GPR146* Gene Locus

Rs1997243, rs2362529, and GPR146 mRNA Expression

GPR146 is ubiquitously expressed, but its expression in the liver has been shown to dictate changes in plasma lipids in *Gpr146*^{-/-} mice.^{2,4} With this in mind, we used eQTL dataset from GTEx to connect genetic variants with *GPR146* expression in human liver.

We first studied rs1997243, the genetic variant that has led to the identification of *GPR146* as a candidate lipid gene,^{1,2,4,24} which is present in 14% of the general population. As can be appreciated from [Figure S2A](#), the alternative G-allele of rs1997243 tends to have higher

GPR146 expression as previously shown by Han et al.² Following close examination of the *GPR146* gene locus, we noticed a second common *GPR146* variant, annotated as rs2362529. This variant has not been studied previously and is present with an allele frequency of 21% in the general population. Opposite to the findings of the alternative allele of rs1997243, the C-allele of rs2362529 is associated with lower *GPR146* expression ([Figure S2B](#)). In both cases, however, these changes did not reach statistical significance which is likely related to the small number of samples (n=208) in this dataset.

To further study *GPR146* expression in carriers of both common variants, we made use of the fact that *GPR146* is also expressed in circulating blood cells and used the eQTL dataset from the eQTLGen consortium, which comprises data of 31 684 human subjects. In line with findings in human liver, carriers of the rs1997243-G allele exhibit higher *GPR146* expression levels in circulating blood than non carriers ($P=3.3 \times 10^{-310}$). In contrast carriers of the rs2362529-C allele exhibit lower *GPR146* mRNA expression in blood than non carriers ($P=1.8 \times 10^{-21}$; [Figure 1A](#)).

The 2 above described common *GPR146* variants are not in linkage disequilibrium ($r^2=0.0172$ in the 1000 genomes population²⁵). This indicates that rs1997243 and rs2362529 can be regarded as independent genetic research instruments with opposite effects on *GPR146* gene expression.

rs1997243 and rs2362529, Lipid Traits, Metabolic Traits, and CRP

To study the phenotypes of carriers of rs1997243 or rs2362529, we used the UK Biobank participants who passed our selection criteria (n=412 444 participants; [Table S1](#); [Figure S2](#)).

Plasma Lipid Traits

[Figure 1B](#) shows that carriers of the rs1997243-G allele (heterozygotes and homozygotes combined) present with higher total cholesterol, LDL-C, high-density lipoprotein cholesterol (HDL-C), with concomitant higher apoB and apoA1 apolipoprotein levels compared with noncarriers, without changes in triglycerides and Lp(a) (lipoprotein [a]; [Table S5](#)). These effects were found to be allele dose dependent ([Figure S3A](#); [Table S6](#)).

In carriers of the rs2362529-C allele, we observed the exact opposite, *ie*, reduced levels of total cholesterol, LDL-C and HDL-C with concomitant reductions in apoB and apoA1 and no changes in plasma triglycerides and Lp(a) compared with noncarriers ([Figure 1B](#); [Table S5](#)). Just like for the other variant, the effects were allele dose-dependent ([Figure S3B](#); [Table S6](#)).

Metabolic Traits and C-Reactive Protein

Although it has been reported that *GPR146* plays a role in the differentiation of adipocytes,³ carriers of rs1997243-G or rs2362529-C do not show differences

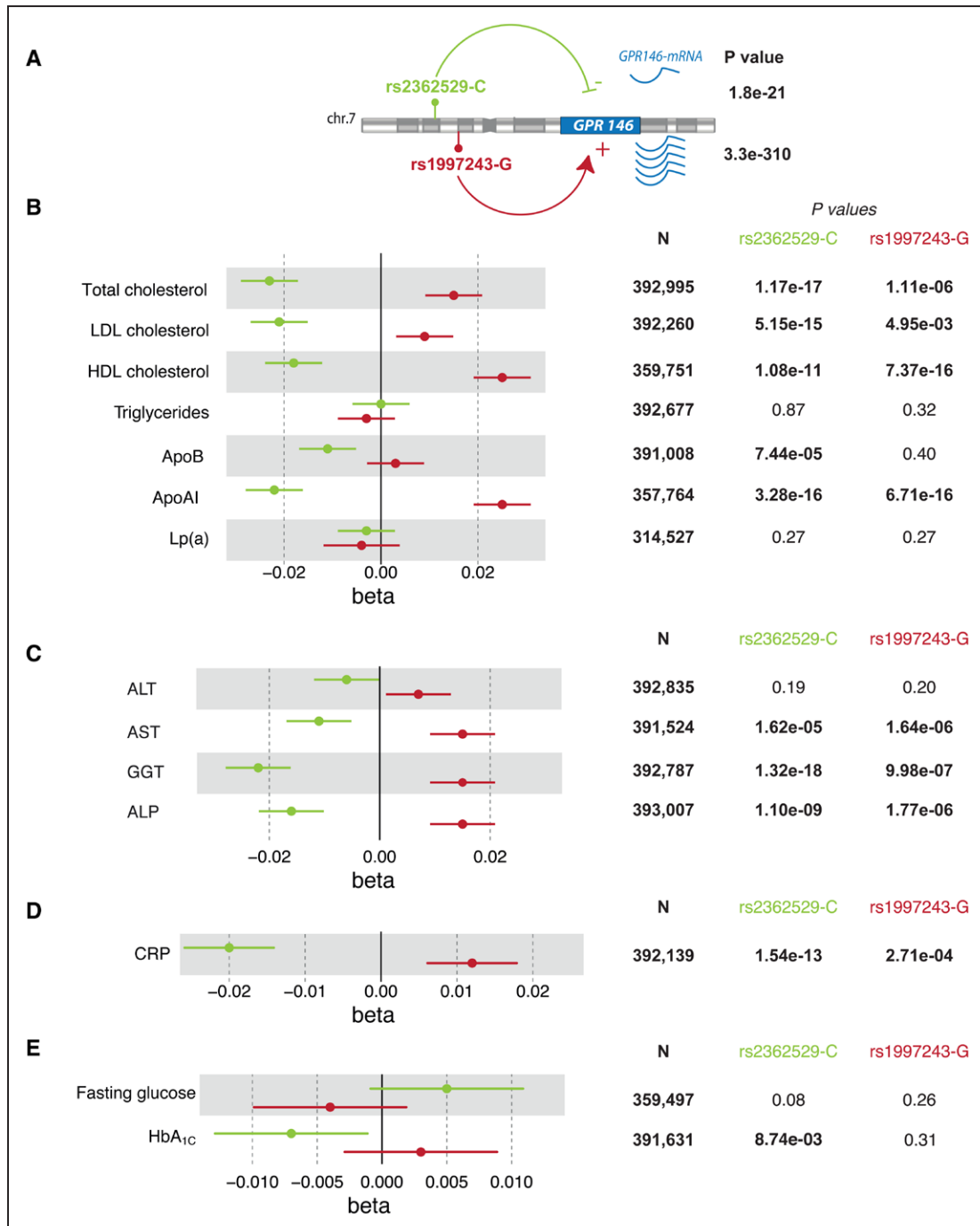

Figure 1. A, Effects of rs2362529 and rs1997243 on the expression of GPR146 in whole blood (Source: <https://www.eqtigen.org>). The upper part of the figure shows the effects of rs2362529 (green arrows) while the bottom part shows the effects of rs1997243 (red arrows) on nearby genes. + and - signs show the direction of the effects with corresponding *P*. **B,** Lipids, lipoproteins, and apolipoproteins in plasma as a function of the C-allele of rs2362529 (green symbols) and the G-allele of rs1997243 (red symbols) in individuals from UK Biobank cohort. The effects are shown as beta-coefficients (per Z-score unit) per C-allele or G-allele compared with noncarriers, respectively. Horizontal bars depict SEs. **C,** Plasma liver enzymes as a function of the C-allele of rs2362529 (green symbols) and the G-allele of rs1997243 (red symbols) in individuals from UK Biobank cohort. The effects are shown as beta-coefficients (per Z-score unit) per C-allele or G-allele compared with noncarriers, respectively. Horizontal bars depict SEs. **D,** Plasma C-reactive protein as a function of the C-allele of rs2362529 (green symbols) and the G-allele of rs1997243 (red symbols) in individuals from UK Biobank cohort. The effects are shown as beta-coefficients per z-score unit) per C-allele or G-allele compared with noncarriers, respectively. Horizontal bars depict SEs. **E,** Plasma glucose or HbA_{1c} levels as a function of the C-allele of rs2362529 (green symbols) and the G-allele of rs1997243 (red symbols) in individuals from UK Biobank cohort. The effects are shown as beta-coefficients (per Z-score unit) per C-allele or G-allele compared with noncarriers. Horizontal bars depict SEs. ALP indicates alkaline phosphatase; ALT, alanine transaminase; ApoAI, apolipoprotein AI; ApoB, apolipoprotein B; AST, aspartate transaminase; CRP, C-reactive protein; GGT, gammaglutamyl-transferases; HbA_{1c}, glycated hemoglobin; LDL, low-density lipoprotein; Lp(a), lipoprotein a; and N; number of individuals included in the analysis.

in body mass index compared with noncarriers (data not shown). Compared with noncarriers, carriers of the rs1997243-G allele are, interestingly, characterized by higher levels of circulating aspartate aminotransferase, gamma-glutamyltransferase and alkaline phosphatase, while the opposite is true for carriers of the rs2362529-C allele (Figure 1C; Tables S5 and S6).

In addition, carriers of rs1997243-G or rs2362529-C allele(s) have higher or lower levels of CRP plasma levels than noncarriers, respectively (Figure 1D; Tables S5 and S6). Finally, carriers of the rs2362529-C allele present with lower glycated haemoglobin (HbA_{1c}) levels than noncarriers (Figure 1E; Tables S5 and S6).

These results indicate that carriers of the rs1997243-G or rs2362529-C allele(s) have unfavorable or favourable lipid and metabolic profiles, respectively. Combined, these findings prompt the question whether these differences translate into an altered risk of coronary artery disease (CAD).

rs1997243, rs2362529, and Risk of CAD

In a meta-analysis from the CARDIoGRAMplusC4D Consortium, carriers of the rs2362529-C allele have marginally reduced CAD compared with noncarriers (Figure 2A). This was anticipated when considering the magnitude of the effect size of this variant on LDL-C levels: homozygotes for rs2362529 show an average decrease of 2.24 mg/dL compared with carriers of wild-type alleles. To study this more closely, we investigated the effects of both *GPR146* gene variants on LDL-C and CAD in the context of well-characterized genetic variants in *APOB*, *PCSK9*, *HMGCR*, *ANGPTL3*¹⁴. As can be appreciated from Figure 2B, *GPR146* rs1997243 and rs2362529 fit the regression line between the magnitude of LDL-C changes and the magnitude of effects on CAD as described by Ference et al.¹⁴

Mendelian Randomization

To assess the causal relationship between *GPR146* expression, CAD, and cardiometabolic outcomes, we ran MR analysis. Our results suggest causal effects of *GPR146* expression on plasma cholesterol levels (total cholesterol, LDL-cholesterol, and HDL-cholesterol), and plasma liver enzymes (alanine aminotransferase, aspartate aminotransferase, gamma-glutamyltransferase, and alkaline phosphatase; Figure S4; Table S6). Despite a trend toward an effect of *GPR146* expression in blood on CAD (logOdds=0.024 per SD higher gene expression, SE=0.015), this effect was not statistically significant ($P=0.098$; Figure S4; Table S7). We found no effect of *GPR146* expression on myocardial infarction. Due to the limited number of instruments, we were unable to assess heterogeneity and directional pleiotropy.

MR using blood eQTLs to instrument *GPR146* expression yielded results that were generally consistent

with the hypothesis that reduced *GPR146* expression causes an improved lipid profile. However, we are unable to rule out that such an effect was driven by variants in LD with our instruments, since *GPR146* expression in blood did not colocalize with most lipid traits (posterior probability for single shared causal variant <0.80). Furthermore, we are uncertain whether blood expression is an appropriate proxy for liver expression. Generation of currently unavailable liver eQTL data for *GPR146* and subsequent MR and colocalization may yield more conclusive evidence.

Rare Variants in the *GPR146* Gene

Identification of a Missense Variant (*GPR146*-p.Pro62Leu)

With the finding that common *GPR146* variants are associated with opposite effects on *GPR146* expression and plasma lipid traits, we set out to identify *GPR146* mutations with large effects on plasma levels of LDL-C. Taken that *Gpr146*^{-/-} mice have reduced LDL-C and are protected against atherosclerosis,⁴ we hypothesized that loss or gain-of-function variants could be found in individuals with low and high LDL-C, respectively. In this effort, we sequenced genomic DNA of individuals with extreme LDL-C plasma levels in the Lifelines and CCHS cohorts (Tables S3 and S4).

Following targeted sequencing, we selected rare variants which affect the protein sequence (or splicing regions) of *GPR146* (Table S8). Most of these rare variants were singletons; however, one missense variant, annotated as rs151124717, was found 8 times in individuals with low LDL-C and only once in an individual with high LDL-C (Figure 3A). The nucleotide substitution (c.185C>T) results in the exchange of Proline for a Leucine residue at position 62 of the mature *GPR146* protein (p.Pro62Leu; Figure 3B). The missense variant is located in the first intracellular loop of *GPR146* and affects a highly evolutionary conserved protein domain (Figure 3C; Figure S5A). This variant is predicted to be damaging by 7 different in silico algorithms (Figure S5B).

Carriers of the *GPR146*-p.Pro62Leu variant in the Lifelines and CCHS cohorts were all heterozygotes and did not carry mutations in genes that are known to cause familial forms of hypocholesterolemia (*APOB*, *MTTP*, *PCSK9*, *ANGPTL3*) or hypercholesterolemia (*LDLR*, *APOB*, *LDLRAP1*, *APOE*, *PCSK9*). In a next step, we screened the UK Biobank for carriers of the *GPR146*-p.Pro62Leu to examine their phenotype more closely.

Carriers of *GPR146*-p.Pro62Leu in the UK Biobank

Plasma Lipid Traits

In the UK Biobank, we identified 2615 carriers of the *GPR146*-p.Pro62Leu variant (Table S9), which

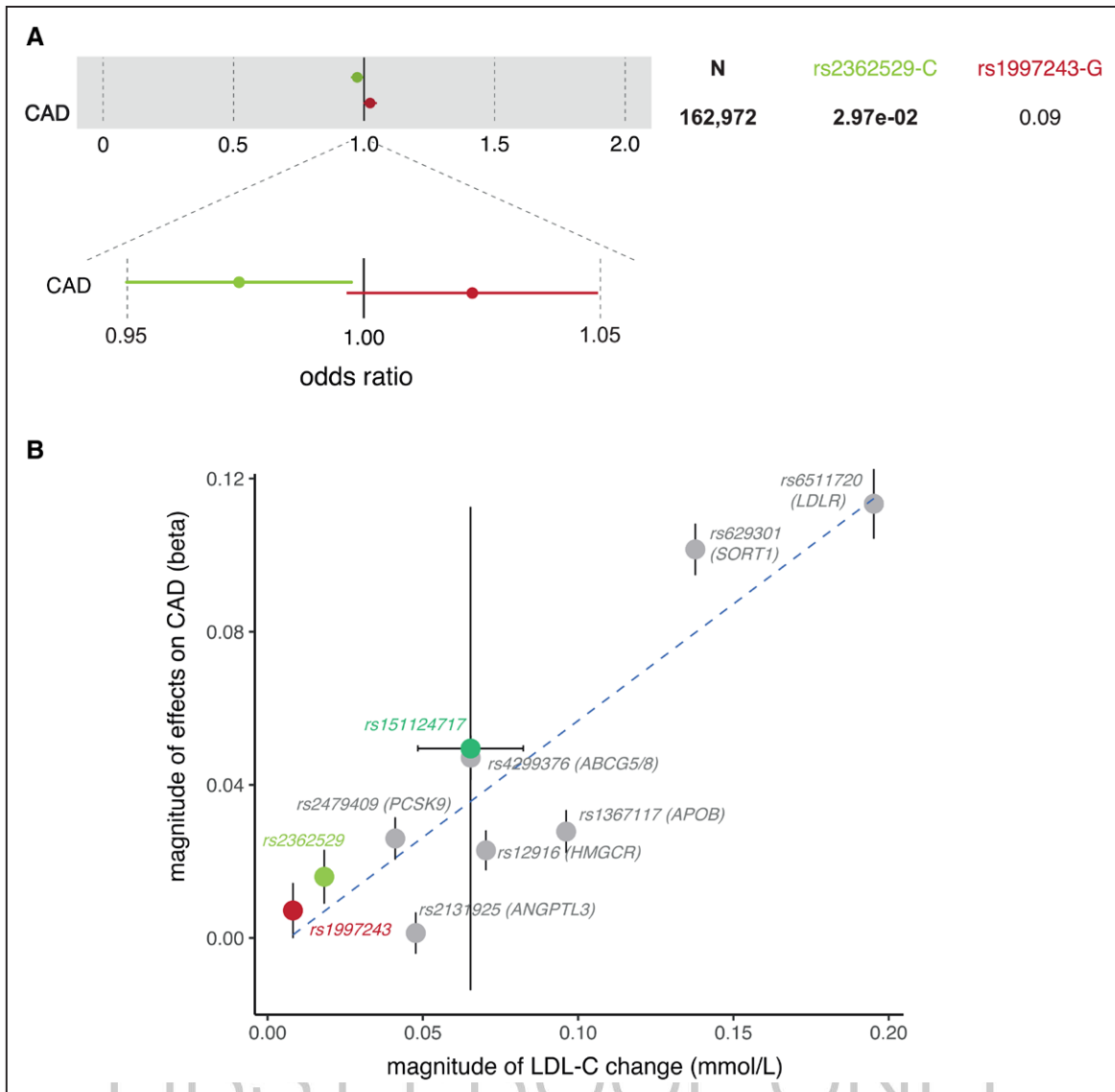

Figure 2. A, Odds ratio for coronary artery disease as a function of the C-allele of rs2362529 and the G-allele of rs1997243 compared with noncarriers.

The effects are shown as odds-ratio per C-allele or G-allele respectively compared with noncarriers. Horizontal bars depict SEs. **B, Proportional risk of coronary artery disease (CAD) associated with different genetic variants that affect low-density lipoprotein-cholesterol (LDL-C) levels.** All values are presented as magnitude of change (positive values). The regression line shows the proportional risk of CAD as a function of genetically determined change in LDL-C (in mmol/L). The vertical and horizontal error bars are SEs for the risk of CAD and LDL-C levels, respectively. N indicates number of individuals included in the analysis.

renders an allele frequency of 0.3% of the general population (in line with data from gnomAD, <https://gnomad.broadinstitute.org/>). In a direct comparison with carriers of the common rs2362529-C allele, it is clear that carriers of the *GPR146*-p.Pro62Leu present with larger reductions of total cholesterol, LDL-C, and HDL-C, which supports the idea that this variant may impair the function of the protein as predicted by the in silico algorithms (Figure 3D, Table S5, Figure S5B). The magnitude of the LDL-C lowering effect of *GPR146*-p.Pro62Leu (rs151124717) correlates with the expected effect on CAD (Figure 2B), but this does not reach statistical significance.

Metabolic Traits and CRP

Carriers of the *GPR146*-p.Pro62Leu variant presented with significant reductions in alkaline phosphatase and gamma-glutamyltransferase when compared with noncarriers (Figure 3E; Table S5). In addition, carriers of the *GPR146*-p.Pro62Leu also presented with significantly reduced CRP levels when compared with noncarriers (Figure 3F; Table S5).

Combined, these data illustrate that carriers of the *GPR146*-p.Pro62Leu variant are characterized by and overall beneficial cardiometabolic phenotype. The remarkable lipid profile of individuals carrying this variant, that is, reductions in all major plasma lipids (Figure 3D),

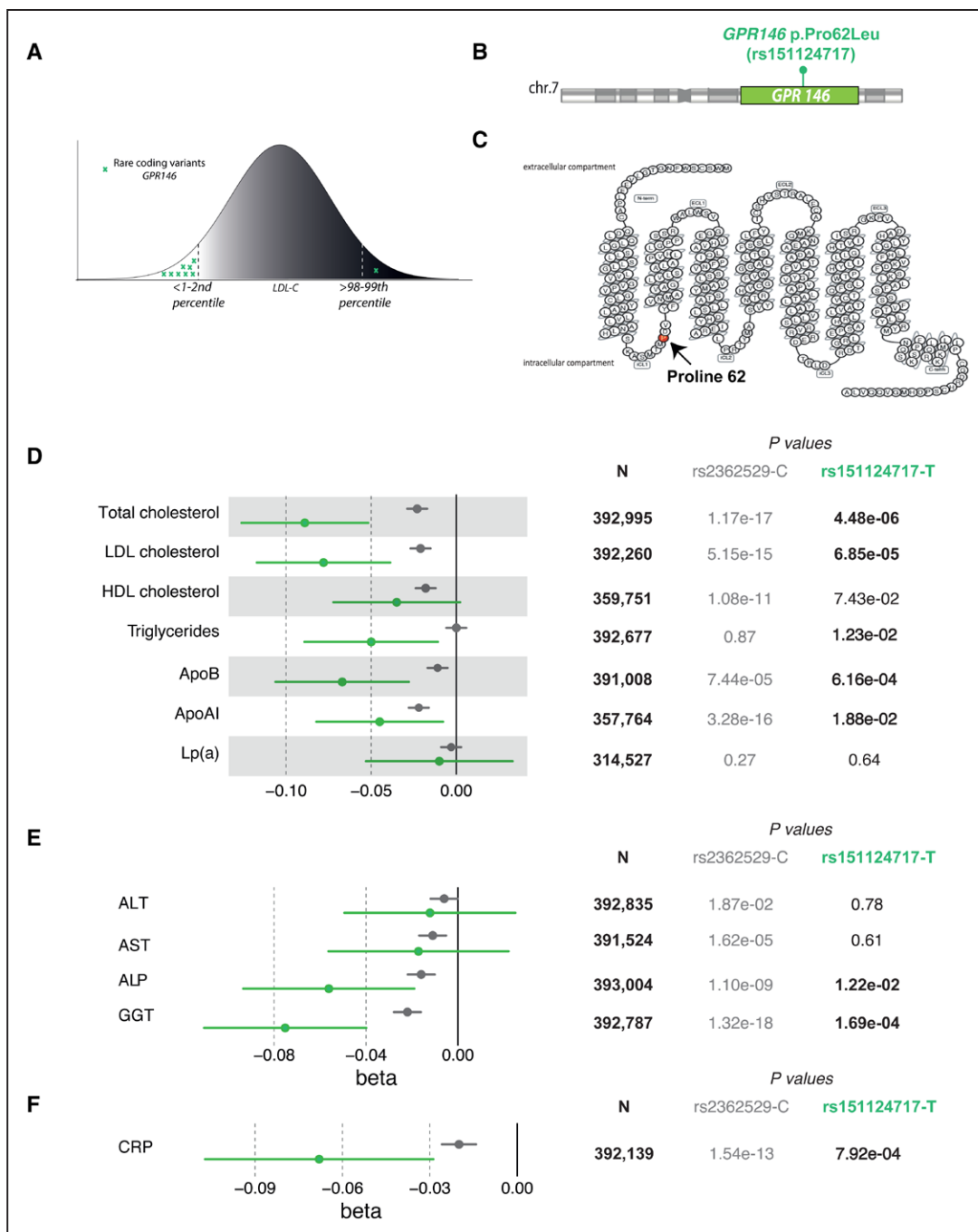

Figure 3. A, Selection of individuals with extreme low-density lipoprotein-cholesterol (LDL-C) plasma levels (<first or second percentile for age and sex from Lifelines cohort and CCHS, respectively and >99th or 98th percentile for age and sex from Lifelines cohort and CCHS, respectively).

Green crosses depict carriers of the GPR146-p.Pro62Leu. **B**, Schematic view of the GPR146 gene located on the 7p22.3 locus and the variant GPR146-p.Pro62Leu (chr7:1057700 (GRCh38.p13); NM_138445.4:c.185C>T; NP_612454.1:p.Pro62Leu). **C**, Schematic view of the predicted amino-acids sequence and protein structure of GPR146. The red arrow indicates the Proline residue at position 62 of the protein located in the first intracellular loop. The total protein consists in 333 amino-acids. **D**, Lipids, lipoproteins, and apolipoproteins in plasma as a function of the T-allele of rs151124717 (green symbols) and the C-allele of rs2362529 (gray symbols) in individuals from the UK Biobank cohort. The effects are shown as beta-coefficients (per z-score unit) per T-allele or C-allele compared with noncarriers respectively. Horizontal bars depict standard errors. **E**, Plasma liver enzymes as a function of the minor T-allele of rs151124717 (green symbols) and the minor C-allele of rs2362529 (gray symbols) in individuals from the UK Biobank cohort. The effects are shown as beta-coefficients (per z-score unit) per T-allele or C-allele compared with noncarriers respectively. Horizontal bars depict standard errors. **F**, Plasma CRP (C-reactive protein) levels as a function of the minor T-allele of rs151124717 (green symbols) and the minor C-allele of rs2362529 (gray symbols) in individuals from the UK Biobank cohort. The effects are shown as beta-coefficients (per z-score unit) per T-allele or C-allele compared with noncarriers. Horizontal bars depict standard errors. ALP indicates alkaline phosphatase; ALT, alanine transaminase; ApoAI, apolipoprotein AI; ApoB, apolipoprotein B; AST; aspartate transaminase; GGT, gammaglutamyl-transferases; Lp(a), lipoprotein a; and N; number of individuals included in the analysis.

resembles those suffering from familial hypocholesterolemia,²⁶ which prompted us to sequence the *GPR146* gene in familial cases with unexplained hypocholesterolemia.

Segregation of *GPR146* p.Pro62Leu With Hypocholesterolemia

In a familial case of hypobetalipoproteinemia from the HYPOCHOL clinical trial,²⁷ in which mutations in canonical lipid genes were excluded, one proband was found to be heterozygous for the *GPR146*-p.Pro62Leu variant (Figure 4). This 24 year-old woman presented with low levels of total cholesterol (124 mg/dL), LDL-C (59 mg/dL), apoB (60 mg/dL), and triglycerides (50 mg/dL), but normal HDL-C (55 mg/dL). We recruited 6 family members and tested co-segregation of the *GPR146*-p.Pro62Leu variant with plasma LDL-C levels in this family (Figure 4; Table S10). The results show the cosegregation of the genotype with the hypobetalipoproteinemia phenotype: all 3 individuals carrying the *GPR146*-Pro62Leu variant present with LDL-C <5th percentile for age and sex.²⁸

DISCUSSION

Previous studies have shown that higher *GPR146* expression in humans is associated with higher plasma lipids. We here present the first evidence that carriers of 2 new *GPR146* variants (rs2362529-C and rs151124717-T) are instead characterized by reduced plasma lipids but also reduced CRP and plasma liver enzymes. Moreover, Mendelian randomization analyses suggest a causal

relationship between *GPR146* gene expression and plasma lipid and liver enzyme levels. In line with a small effect of the rs2362529-C variant on LDL-C, we find a marginal reduction on CAD risk reduction in carriers of this variant which needs further investigation.

The plasma lipid profiles of carriers of the common *GPR146* variants are unique in that they are associated with higher or lower apoB as well as apoA1-containing lipoproteins levels but without changes in plasma triglycerides. The biological relevance of these observations is highlighted by the fact that heterozygotes and homozygotes of the common rs1997243-C allele and rs2362529-C show exact opposite phenotypes. While loss-of-function variants in *ANGPTL3* are also associated with reductions in LDL-C and HDL-C, these variants are also causing marked reductions in triglycerides.^{29,30}

In an attempt to learn more about how *GPR146* may affect lipid and lipoprotein metabolism, we set out to identify *GPR146* mutations with larger effect sizes and found that *GPR146*-p.Pro62Leu was overrepresented in subjects with low LDL-C compared with individuals with high LDL-C. This variant is predicted to damage protein function by all in silico predictors we used (SIFT, Polyphen2, LRT, Mutation tester, etc) and affects a highly conserved residue. In the UK-Biobank, 2615 heterozygote carriers of this variant showed more pronounced reductions in total cholesterol and LDL-C compared with carriers of the common rs2362529 variant. This suggests that *GPR146*-p.Pro62Leu may be a functional mutation but we were not able to validate this (data now shown). On the other hand, although we found that the *GPR146*-p.Pro62Leu variant co-segregates with low LDL-C in

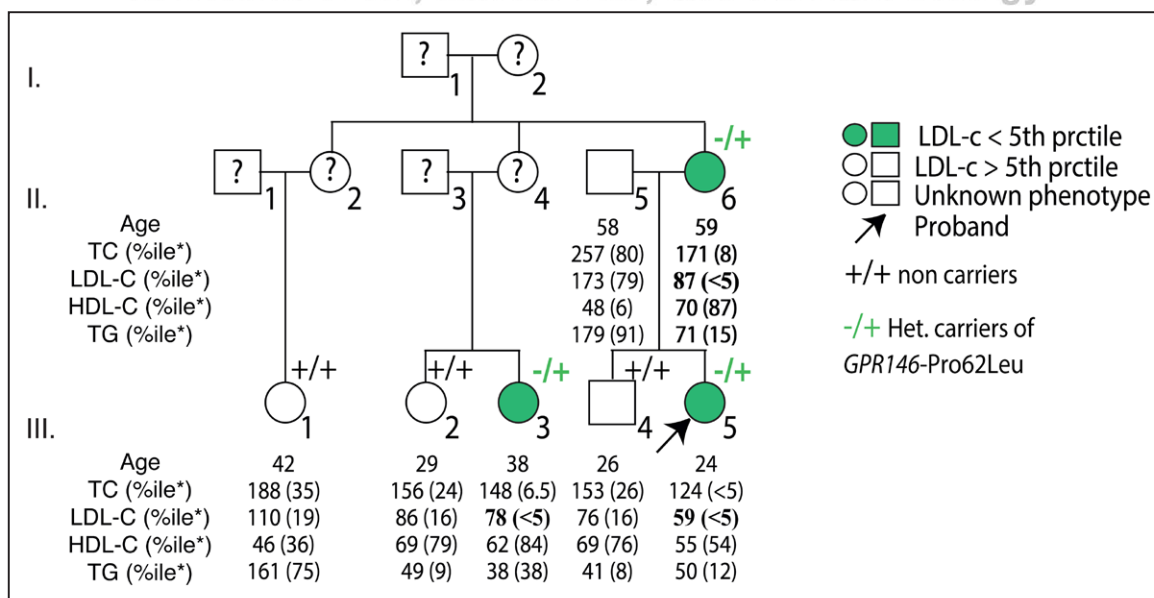

Figure 4. Pedigree of a family with familial hypobetalipoproteinemia.

Carriers of the *GPR146*-p.Pro62Leu variant are depicted with green symbols (II:6, III:3, and III:5/proband) and all have low-density lipoprotein cholesterol (LDL-C) values below the 5th percentile. Total cholesterol (TC), LDL-C, high-density lipoprotein cholesterol (HDL-C), and triglycerides plasma levels are presented in mg/dL. Circles=women and squares=men; *Values between brackets show percentile for corresponding values adjusted for age and sex.

a family with unresolved hypocholesterolemia, further studies remain needed to establish *GPR146* as a candidate gene for human hypobetalipoproteinemia.

In contrast to products of established genes in lipid metabolism such as *APOB*, *MTP*, *APOC3*, *ANGPTL3*, and *LDLR*, the GPR146 protein is not directly involved in the machinery to synthesize lipoproteins or to clear them from the circulation. It is, in fact, the first protein of its class known to date to control plasma lipid traits through cellular signaling pathways. In mice GPR146 has previously been shown to increase de novo cholesterol synthesis in the liver through activation of the extracellular signal-regulated kinase signaling pathway.⁴ The downstream effect on hepatic VLDL secretion was shown to contribute to the plasma lipid phenotype of *Gpr146*^{-/-} mice. Whether these findings translate to humans remains to be established through, for example, stable isotope studies.

Our study surprisingly reveals an association of GPR146 with plasma levels of CRP, a biomarker for systemic inflammation, which is of interest^{31,32} when considering the central role of inflammation in atherogenesis.³³ In addition, the loss of GPR146 function is not associated with elevated hepatic enzymes, commonly used as markers of hepatic steatosis or nonalcoholic fatty liver disease, an adverse effect of both Mipomersen (an *APOB* antisense oligonucleotide) and Lomitapide (a small molecule MTP inhibitor) used to treat homozygous familial hypercholesterolemia.³⁴ These findings combined suggest that GPR146 antagonists may have favorable effects over existing medication.

Taken together, this study shows for the first time that variants in the *GPR146* gene locus are associated with a favorable cardiometabolic risk profile. Although these results support the development of GPR146 antagonists, it also highlights our incomplete understanding of how plasma levels of apoB and apoA1-containing lipoproteins are regulated. Identification of ligands of this receptor, which is ubiquitously expressed, will hopefully leverage our understanding.

ARTICLE INFORMATION

Received February 2, 2022; accepted August 12, 2022.

Affiliations

Nantes Université, CHU Nantes, CNRS, INSERM, l'institut du thorax, France (A.R., A.G., L.B., A.C., M.M., B.C.). Department of Cardiology (M.W.Y., S.W., M.S., P.v.d.H.), Department of Pediatrics, Section Molecular Genetics (N.L., B.v.d.S., J.K.), Department of Genetics (A.v.d.G.), Department of Epidemiology (C.H.L.T., S.W., H.S.), and Sections of Molecular Metabolism and Nutrition, Department of Pediatrics (V.W.B.), University Medical Center Groningen, University of Groningen, the Netherlands. Department of Cardiology, Division of Heart and Lungs, University Medical Center Utrecht, University of Utrecht, the Netherlands (M.W.Y., P.v.d.H.). Section for Molecular Genetics, Department of Clinical Biochemistry, Rigshospitalet, Copenhagen University Hospital, Faculty of Health and Medical Sciences, University of Copenhagen, Denmark (N.D., A.T.-H.). Department of Biochemistry, Yong Loo Lin School of Medicine, National University of Singapore (H.Y.). Precision Medicine Research Programme, Yong Loo Lin School of Medicine, National University of Singapore (H.Y.). Department of Molecular Genetics, University

of Texas Southwestern Medical Center, Dallas (F.O.). Department of Medicine, Division of Endocrinology, and Einthoven Laboratory for Experimental Vascular Medicine, Leiden University Medical Center, the Netherlands (L.L.B., P.C.N.R.). CarMen Laboratory, INSERM, INRA, INSA Lyon, Université Claude Bernard Lyon 1, Pierre-Bénite, France (P.M., M.D.F.). Hospices Civils de Lyon, Fédération d'endocrinologie, maladies métaboliques, diabète et nutrition, Hôpital Louis Pradel, Bron, France (P.M.). Hospices Civils de Lyon, UF Dyslipidémies Service de Biochimie et de Biologie Moléculaire Grand Est, Bron, France (M.D.F.). Department of Clinical Biochemistry, Rigshospitalet, Copenhagen, Denmark (A.T.-H.). The Copenhagen City Heart Study, Bispebjerg and Frederiksberg Hospital, Denmark (A.T.-H.). NEBION AG, Zurich, Switzerland (P.Z.).

Acknowledgments

The authors acknowledge the use of data from various consortia and clinical trials: UK Biobank (<https://www.ukbiobank.ac.uk>); eQTLGen consortium (<https://www.eqtngen.org>); CARDIoGRAMplusC4D consortium (<http://www.cardiogramplusc4d.org/>); HYPOCHOL (<https://clinicaltrials.gov/ct2/show/NCT02354079/>); Lifelines (<https://www.lifelines.nl/>); Copenhagen City Heart Study. We thank all participants of these different cohorts and authors that made summary statistics of genome wide association studies publicly available. We thank the biological resource centre for biobanking (CHU Nantes, Nantes Université, Centre de ressources biologiques (BB-0033-00040), F-44000 Nantes, France. We are most grateful to the Genomics & Bioinformatics Core Facilities of Nantes (GenoA & BiRD, Biogenouest) and the Institut Français de Bioinformatique (IFB; ANR-11-INBS-0013) for their technical support.

Sources of Funding

This work was supported by grants the Netherlands CardioVascular Research Initiative: "the Dutch Heart Foundation, Dutch Federation of University Medical Centers, the Netherlands Organization for Health Research and Development and the Royal Netherlands Academy of Sciences" (CVON2017-2020; Acronym Genius2 to P.C.N. Rensen, B. van de Sluis, and J. Kuivenhoven). J. Kuivenhoven is Established Investigator of the Netherlands Heart Foundation (2015T068). The Research Fund at Rigshospitalet, Copenhagen University Hospital, a grant from the Odd Fellow Order, the 2018 Anitschkow Award from the European Atherosclerosis Society, and Kirsten and Freddy Johansen's Award 2018. B. Cariou and A. Rimbert were supported by the French national project CHOPIN (CHolesterol Personalized INnovation) funded by the Agence Nationale de la Recherche (ANR-16-RHUS-0007) and coordinated by the CHU of Nantes, a grant from the Fondation de France (grant No. 2015-00047967) and the GENESIS project, funded by the Agence Nationale de la Recherche (ANR-21-CE14-0051). A.R. is supported by a post-doctoral fellowship grant from the "Fondation Recherche Médicale."

Disclosures

None.

Supplemental Material

Figures S1–S5
Tables S1–S10
References S1–S15

REFERENCES

- Willer CJ, Schmidt EM, Sengupta S, Peloso GM, Gustafsson S, Kanoni S, Ganna A, Chen J, Buchkovich ML, Mora S, et al; Global Lipids Genetics Consortium. Discovery and refinement of loci associated with lipid levels. *Nat Genet*. 2013;45:1274–1283. doi: 10.1038/ng.2797
- Han F, Liu X, Chen C, Liu Y, Du M, Zhou Y, Liu Y, Song BL, He HH, Wang Y. Hypercholesterolemia risk-associated GPR146 is an orphan G-protein coupled receptor that regulates blood cholesterol levels in humans and mice. *Cell Res*. 2020;30:363–365. doi: 10.1038/s41422-020-0303-z
- <https://www.easdo.org/virtualmeeting/home.html#resources/crispr-cas9-induced-knockout-of-gpr146-in-mouse-3t3-l1-fibroblasts-blunted-differentiation-into-adipocytes-28081dbf-21a1-4ae7-8e14-1f1c4209525d>.
- Yu H, Rimbert A, Palmer AE, Toyohara T, Xia Y, Xia F, Ferreira LMR, Chen Z, Chen T, Loaiza N, et al; BIOS Consortium. GPR146 deficiency protects against hypercholesterolemia and atherosclerosis. *Cell*. 2019;179:1276–1288.e14. doi: 10.1016/j.cell.2019.10.034
- Wacker D, Stevens RC, Roth BL. How ligands illuminate GPCR molecular pharmacology. *Cell*. 2017;170:414–427. doi: 10.1016/j.cell.2017.07.009
- Crunkhorn S. GPR146 inhibition protects against atherosclerosis. *Nat Rev Drug Discov*. 2020;19:22. doi: 10.1038/d41573-019-00204-7

7. Fernández-Ruiz I. GPR146 is a potential new therapeutic target for lipid lowering. *Nat Rev Cardiol*. 2019;17:132–133. doi: 10.1038/s41569-019-0328-5
8. Yosten GL, Kolar GR, Redlinger LJ, Samson WK. Evidence for an interaction between proinsulin C-peptide and GPR146. *J Endocrinol*. 2013;218:B1–B8.
9. Lindfors L, Sundström L, Fröderberg Roth L, Meuller J, Andersson S, Kihlberg J. Is GPR146 really the receptor for proinsulin C-peptide? *Bioorg Med Chem Lett*. 2020;30:127208. doi: 10.1016/j.bmcl.2020.127208
10. GTEx Consortium, Laboratory, Data Analysis & Coordinating Center (LDACC)—Analysis Working Group, Statistical Methods groups—Analysis Working Group, et al. Genetic effects on gene expression across human tissues. *Nature*. 2017;550:204–213. doi: 10.1038/nature24277
11. Vösa U, Claringbould A, Westra HJ, Bonder MJ, Deelen P, Zeng B, Kirsten H, Saha A, Kreuzhuber R, Yazar S, et al; BIOS Consortium; i2QTL Consortium. Large-scale cis- and trans-eQTL analyses identify thousands of genetic loci and polygenic scores that regulate blood gene expression. *Nat Genet*. 2021;53:1300–1310. doi: 10.1038/s41588-021-00913-z
12. Sudlow C, Gallacher J, Allen N, Beral V, Burton P, Danesh J, Downey P, Elliott P, Green J, Landray M, et al. UK biobank: an open access resource for identifying the causes of a wide range of complex diseases of middle and old age. *PLoS Med*. 2015;12:e1001779. doi: 10.1371/journal.pmed.1001779
13. Nikpay M, Goel A, Won HH, Hall LM, Willenborg C, Kanoni S, Saleheen D, Kyriakou T, Nelson CP, Hopewell JC, et al. A comprehensive 1,000 Genomes-based genome-wide association meta-analysis of coronary artery disease. *Nat Genet*. 2015;47:1121–1130. doi: 10.1038/ng.3396
14. Ference BA, Ginsberg HN, Graham I, Ray KK, Packard CJ, Bruckert E, Hegele RA, Krauss RM, Raal FJ, Schunkert H, et al. Low-density lipoproteins cause atherosclerotic cardiovascular disease. 1. Evidence from genetic, epidemiologic, and clinical studies. A consensus statement from the European Atherosclerosis Society Consensus Panel. *Eur Heart J*. 2017;38:2459–2472. doi: 10.1093/eurheartj/ehx144
15. van der Harst P, Verweij N. Identification of 64 novel genetic loci provides an expanded view on the genetic architecture of coronary artery disease. *Circ Res*. 2018;122:433–443. doi: 10.1161/CIRCRESAHA.117.312086
16. Yavorska OO, Burgess S. MendelianRandomization: an R package for performing Mendelian randomization analyses using summarized data. *Int J Epidemiol*. 2017;46:1734–1739. doi: 10.1093/ije/dyx034
17. Giambartolomei C, Vukcevic D, Schadt EE, Franke L, Hingorani AD, Wallace C, Plagnol V. Bayesian testing for colocalisation between pairs of genetic association studies using summary statistics. *PLoS Genet*. 2014;10:e1004383. doi: 10.1371/journal.pgen.1004383
18. Klijs B, Scholtens S, Mandemakers JJ, Snieder H, Stolk RP, Smidt N. Representativeness of the lifelines cohort study. *PLoS One*. 2015;10:e0137203. doi: 10.1371/journal.pone.0137203
19. Scholtens S, Smidt N, Swertz MA, Bakker SJ, Dotinga A, Vonk JM, van Dijk F, van Zon SK, Wijmenga C, Wolffenbuttel BH, et al. Cohort Profile: LifeLines, a three-generation cohort study and biobank. *Int J Epidemiol*. 2015;44:1172–1180. doi: 10.1093/ije/dyu229
20. Balder JW, Rimbert A, Zhang X, Viel M, Kanninga R, van Dijk F, Lansberg P, Sinke R, Kuivenhoven JA. Genetics, lifestyle, and low-density lipoprotein cholesterol in young and apparently healthy women. *Circulation*. 2018;137:820–831. doi: 10.1161/CIRCULATIONAHA.117.032479
21. Aguib Y, Al Suwaidi J. The Copenhagen City Heart Study (Østerbroundersøgelsen). *Glob Cardiol Sci Pract*. 2015;2015:33. doi: 10.5339/gcsp.2015.33
22. Rimbert A, Dalila N, Wolters JC, Huijckman N, Smit M, Kloosterhuis N, Riemsma M, van der Veen Y, Singla A, van Dijk F, et al; Biobank-Based Integrative Omics Studies Consortium. A common variant in CDC93 protects against myocardial infarction and cardiovascular mortality by regulating endosomal trafficking of low-density lipoprotein receptor. *Eur Heart J*. 2020;41:1040–1053. doi: 10.1093/eurheartj/ehz727
23. Marmontel O, Rollat-Farnier PA, Wozny AS, Charrière S, Vanhoye X, Simonet T, Chatron N, Collin-Chavagnac D, Nony S, Dumont S, et al. Development of a new expanded next-generation sequencing panel for genetic diseases involved in dyslipidemia. *Clin Genet*. 2020;98:589–594. doi: 10.1111/cge.13832
24. Klarin D, Damrauer SM, Cho K, Sun YV, Teslovich TM, Honerlaw J, Gagnon DR, DuVall SL, Li J, Peloso GM, et al; Global Lipids Genetics Consortium; Myocardial Infarction Genetics (MIGen) Consortium; Geisinger-Regeneron DiscovEHR Collaboration; VA Million Veteran Program. Genetics of blood lipids among ~300,000 multi-ethnic participants of the Million Veteran Program. *Nat Genet*. 2018;50:1514–1523. doi: 10.1038/s41588-018-0222-9
25. Machiela MJ, Chanock SJ. LDlink: a web-based application for exploring population-specific haplotype structure and linking correlated alleles of possible functional variants. *Bioinformatics*. 2015;31:3555–3557. doi: 10.1093/bioinformatics/btv402
26. Kuivenhoven JA, Hegele RA. Mining the genome for lipid genes. *Biochim Biophys Acta*. 2014;1842:1993–2009. doi: 10.1016/j.bbdis.2014.04.028
27. Rimbert A, Vanhoye X, Coulibaly D, Marrec M, Pichelin M, Charrière S, Peretti N, Valéro R, Wargny M, Carrié A, et al. Phenotypic differences between polygenic and monogenic hypobetalipoproteinemia. *Arterioscler Thromb Vasc Biol*. 2021;41:e63–e71. doi: 10.1161/ATVBAHA.120.315491
28. Nurmohamed NS, Collard D, Balder JW, Kuivenhoven JA, Stroes ESG, Reeskamp LF. From evidence to practice: development of web-based Dutch lipid reference values. *Neth Heart J*. 2021;29:441–450. doi: 10.1007/s12471-021-01562-x
29. Musunuru K, Pirruccello JP, Do R, Peloso GM, Guiducci C, Sougnez C, Garimella KV, Fisher S, Abreu J, Barry AJ, et al. Exome sequencing, ANGPTL3 mutations, and familial combined hypolipidemia. *N Engl J Med*. 2010;363:2220–2227. doi: 10.1056/NEJMoa1002926
30. Stitzel NO, Khera AV, Wang X, Bierhals AJ, Vourakis AC, Sperry AE, Natarajan P, Klarin D, Emdin CA, Zekavat SM, et al; PROMIS and Myocardial Infarction Genetics Consortium Investigators. ANGPTL3 deficiency and protection against coronary artery disease. *J Am Coll Cardiol*. 2017;69:2054–2063. doi: 10.1016/j.jacc.2017.02.030
31. Nissen SE, Tuzcu EM, Schoenhagen P, Crowe T, Sasiela WJ, Tsai J, Orazem J, Magorien RD, O'Shaughnessy C, Ganz P; Reversal of Atherosclerosis with Aggressive Lipid Lowering (REVERSAL) Investigators. Statin therapy, LDL cholesterol, C-reactive protein, and coronary artery disease. *N Engl J Med*. 2005;352:29–38. doi: 10.1056/NEJMoa042000
32. Ligthart S, Vaez A, Vösa U, Stathopoulou MG, de Vries PS, Prins BP, Van der Most PJ, Tanaka T, Naderi E, Rose LM, et al; LifeLines Cohort Study; CHARGE Inflammation Working Group. Genome analyses of >200,000 individuals identify 58 loci for chronic inflammation and highlight pathways that link inflammation and complex disorders. *Am J Hum Genet*. 2018;103:691–706. doi: 10.1016/j.ajhg.2018.09.009
33. Libby P. The changing landscape of atherosclerosis. *Nature*. 2021;592:524–533. doi: 10.1038/s41586-021-03392-8
34. Blom DJ, Raal FJ, Santos RD, Marais AD. Lomitapide and Mipomersen—Inhibiting Microsomal Triglyceride Transfer Protein (MTP) and apoB100 Synthesis. *Curr Atheroscler Rep*. 2019;21:48. doi: 10.1007/s11883-019-0809-3