

A dose verification method for high-dose-rate brachytherapy treatment plans

ABSTRACT

Aim: To evolve a fast dose verification method for high-dose-rate (HDR) brachytherapy treatment plans and to demonstrate its applicability in different clinical cases.

Materials and Methods: We developed a software tool in VC++ for the Varisource HDR unit for HDR dosimetry plan verification using TG-43 parameters. HDR treatment dosimetry of a number clinical cases using Varisource was verified by comparison with the treatment planning system (TPS).

Results: A number of different types of clinical cases treated by Varisource were evaluated. TPS calculated dose values and verification code calculated dose values were found to agree to within 3% for most of the dose calculation points.

Conclusions: We have validated with clinical cases a fast and independent dose verification method of the dosimetry at selected points for HDR brachytherapy treatments plan using TG-43 parameters. This can be used for the verification of the TPS calculated dose at various points. The code is written to work with Varisource, but it can conceivably be modified for other sources also by using the fitted constant of the respective source.

KEY WORDS: Brachytherapy, dose verification, dosimetry, TG-43 formalism, treatment planning

INTRODUCTION

High-dose-rate (HDR) brachytherapy has proven to be an effective treatment in the definitive management of different types of cancers and is a common treatment modality in most radiotherapy clinics. In HDR brachytherapy treatment planning, the identification of applicators is done using simulator films or 3D images such as CT, and the dwell times along these catheters are then optimized in order to deliver prescribed doses at one or more anatomical points while simultaneously satisfying various constraints. The importance of independent verification of the dosimetry prior to the treatment delivery has been recognized worldwide and is also specified in the AERB safety code as well as in the guidelines of other international regulatory agencies.^[1] The planning system provides many different possibilities for dose optimization; for example, it allows alteration of the optimized plan by either pulling the isodose lines with the mouse or by directly modifying the dwell times. The complex nature of the treatment planning process means that many approaches can be used to arrive at a final plan, making it possible that a software bug that escaped discovery during commissioning may introduce error in the dosimetry if the planning steps are completed in a different order than usual. This makes a second check of the dose especially

useful. Treatment planning systems using a stepping source, which can be interfaced with multimodality images (CT/MRI/ultrasound) and sophisticated dose optimization software, enable the planner to maximize the dose uniformity, while minimizing the implant volume needed to cover the target volume adequately and, at the same time, reduces the dose to the organs at risk. Such flexibility creates a challenge for the verification of the optimized calculations with practical manual calculation techniques that take only a few minutes but at the same time give a high probability of detecting significant errors. Verification of the dose calculation on a pretreatment basis, however, ensures that the correct source is being used; that the source data has not been modified and correct activity, treatment date, and decay are used; and that any bugs in the planning software did not affect the dose calculation. HDR treatment plans involve a number of dwell positions, which makes manual calculations of dose distribution, and hence of the treatment time, impractical. Although TPS facilitates the determination of the dose optimization and treatment time calculation, verification of the TPS calculated dose can pose a challenge. Most of the dose verification methods previously published are specific to particular types of clinical treatments. In this paper we describe an independent method for use in verifying HDR

**Rajesh Kumar,
SD Sharma,
Vijaykumar C¹,
Sudesh Deshpande²,
PK Sharma³,
Vandana S,
Philomena A,
Ravi H Chilkulwar**

Radiological Physics and Advisory Division, Bhabha Atomic Research Centre, CT and CRS, Anushaktinagar, Mumbai-400 094, ¹Department of Radiology, Armed Force Medical College, Pune, ²PD Hinduja National Hospital and Research Centre, Mahim, Mumbai, ³Tata Memorial Hospital, Parel, Mumbai, India

For correspondence:

Rajesh Kumar,
Radiological Physics and Advisory Division, Bhabha Atomic Research Centre, CT and CRS, Anushaktinagar, Mumbai-400 094, India. E-mail: raj_res@rediffmail.com

dosimetry of different types of clinical cases based on the AAPM TG-43 formalism^[2] and Cartesian coordinates obtained from the TPS.

MATERIALS AND METHODS

The verification software code was written in VC++ for the Varisource (new design) HDR brachytherapy unit. In order to verify errors which may occur between the planning and delivery stages, the verification code uses geometrical information such as dwell time (in seconds), Cartesian coordinates (in centimeters) of dwell position, and calculation point coordinates (in centimeters) directly from the TPS, as well as air kerma strength (AKS; cGy/cm²/h) at treatment date, which has to be entered independently by the user. The following AAPM TG-43 formalism^[2] was used for dose calculation in the verification code:

$$D(r, \theta) = S_k \Lambda \left[\frac{G(r, \theta)}{G(r_0, \theta_0)} \right] g(r) F(r, \theta) t \dots \dots \dots (1)$$

where S_k is the AKS of the source, Λ is the dose rate constant, $G(r, \theta)$ is the geometry factor, $g(r)$ is the radial dose function, $F(r, \theta)$ is the anisotropy function, r is the distance between the dose point and the centre of the source, t is dwell time in second, θ is the angle subtended by the central axis of the source and line connecting the centre of the source and the dose point, and r_0 and θ_0 are reference parameters taken to be 1 cm and 90°, respectively [Figure 1]. Analytically fitted formulae based on the Monte Carlo data of Angelopoulos *et al.*^[3,5] for the source were used to find out $g(r)$ and $F(r, \theta)$ for the desired point of dose calculation.

For the radial dose function, the general functional form used in this study was^[3] as follows:

$$g(r) = \frac{hr^i}{1 + jr^k} \dots \dots \dots (2)$$

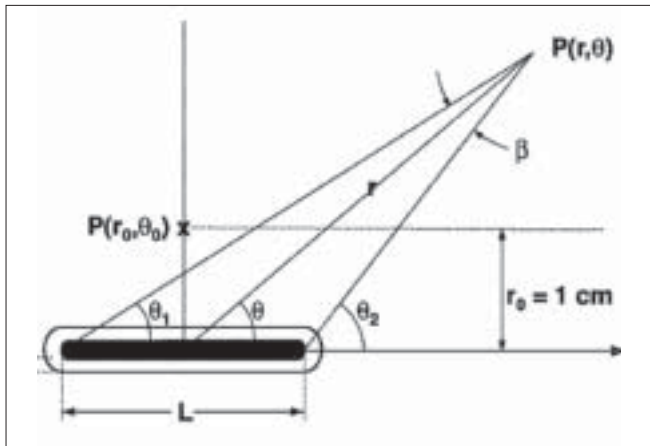

Figure 1: Radial and angular co-ordinate definition with respect to source used in AAPM TG-43 formalism

where h, i, j, and k are fitted constants from Monte Carlo data of the respective HDR source.

For the geometry function the following expression was used in this study^[4]:

$$G(r, \theta) = \frac{\arctan[L/(2r \sin \theta) + \cot \theta] + \arctan[L/(2r \sin \theta) - \cot \theta]}{L r \sin \theta} \dots \dots \dots (3)$$

where L is the active length of source.

The following expression was used to calculate anisotropy function in this study:^[3]

$$F(r, \theta) = k(r) + \frac{a(r)(\theta/\pi)^{e(r)}}{1 + b(r)(\theta/\pi)^{e(r)}} + \frac{a'(r)(1 - \theta/\pi)^{e'(r)}}{1 + b'(r)(1 - \theta/\pi)^{e'(r)}} \dots \dots \dots (4)$$

where

$$\begin{aligned} k(r) &= k_1 r^{k_2} + k_3 r + k_4; \\ a(r) &= a_1 r^{a_2} + a_3 r + a_4; \\ b(r) &= b_1 r^{b_2} + b_3 r + b_4; \\ e(r) &= e_1 r^{e_2} + e_3 r + e_4; \\ a'(r) &= a'_1 r^{a'^2} + a'_3 r + a'_4; \\ b'(r) &= b'_1 r^{b'^2} + b'_3 r + b'_4; \\ e'(r) &= e'_1 r^{e'^2} + e'_3 r + e'_4 \end{aligned}$$

are fitted constants from Monte Carlo data of the respective HDR source. Values of fitted constants for Varisource are given in Tables 1 and 2.

For Cartesian dwell coordinates (Xi, Yi, Zi) and corresponding dwell time, the dose at any point (Xr, Yr, Zr) can be calculated using the following formula:

$$D(Xr, Yr, Zr) = \sum_{i=0}^n D(r, \theta) i$$

where $D(r, \theta)$ can be calculated from Equation 1, while r and θ can be calculated as:

$$r = \sqrt{(Xr - Xi)^2 + (Yr - Yi)^2 + (Zr - Zi)^2}$$

and

$$\theta = \arccos \left[\frac{\mathbf{r1} \cdot \mathbf{r2}}{\|\mathbf{r1}\| \cdot \|\mathbf{r2}\|} \right]$$

where r_1 and r_2 are vectors, as shown in Figure 2.

Dose rate constant reported by Angelopoulos *et al.*^[5] 1.101 for

Table 1: Fitted values of constant used for calculating g(r)

	h	i	j	k
Varisource	1	8.4E-3	9.9742E-5	3.197

Table 2: Fitted values of constant used for calculating $F(r,\theta)$

i	ki	ai	bi	ei	a'i	b'i	e'i
1	5.372E-2	2.4E-2	5.447	1.559	-1.9E-2	3.766E-2	-2.169E-1
2	-1.113	0	-1.37	-3.25E-2	0	-3.3867	-5.68E-1
3	3.7078E-2	-1.6029	-8.777E-1	-5.9E-3	-9.482E-1	8.11E-1	-9.8E-3
4	-1.184E-1	40.663	64.17	-1.35E-1	33.4	64.01	1.6675

Table 3 (a): Comparison of treatment planning system calculated and verification code calculated dose values for intracavitary brachytherapy treatment plans

Calculation point	TPS calculated dose (cGy)	Verification code calculated dose (cGy)	% Variation
Point A (left)	504	529.183	-2.044
Point A (right)	578.4	569.681	-1.471
Bladder 1	236.2	236.497	0.125
Bladder 2	376.6	374.322	-0.6086
Bladder 3	354.7	359.38	1.3021
Rectum 1	379.7	379.694	-0.0016
Rectum 2	209.1	212.291	1.5029
Rectum 3	97.4	96.8055	-0.6141
Rectum 4	45.1	45.0969	-0.0069

TPS: Treatment planning system

Table 3(b): Comparison of treatment planning system calculated and verification code calculated dose values for central vaginal sources brachytherapy treatment plans

Calculation point	TPS calculated dose (cGy)	Verification code calculated dose (cGy)	% Variation
Ref. line (left) 1	761.9	761.947	0.0061
Ref. line (left) 2	772.2	770.645	-0.2018
Ref. line (left) 3	711.5	715.966	0.6238
Ref. line (right) 1	761.9	759.998	-0.2502
Ref. line (right) 2	772.2	771.135	-0.138
Ref. line (right) 3	711.5	711.013	-0.0684
Bladder 1	171.4	170.924	-0.2782
Bladder 2	292.8	292.296	-0.1724
Bladder 3	439.3	439.475	0.03975
Rectum 1	163.3	167.209	2.337
Rectum 2	383.2	383.132	-0.0178
Rectum 3	293.7	291.741	-0.6715
Rectum 4	60.2	60.5389	0.5598

TPS: Treatment planning system

Table 3 (c): Comparison of treatment planning system calculated and verification code calculated dose values for Intraluminal brachytherapy treatment plans

Calculation point	TPS calculated dose (cGy)	Verification code calculated dose (cGy)	% Variation
Ref. line (left) 1	474.1	466.6	-1.6073
Ref. line (left) 2	522.3	521.318	-0.1882
Ref. line (left) 3	568.2	568.364	0.02889
Ref. line (left) 4	576.3	575.641	-0.1144
Ref. line (left) 5	598.5	600.47	0.3281
Ref. line (left) 6	520.1	525.744	1.073
Ref. line (right) 1	414.7	423.071	1.9785
Ref. line (right) 2	504.9	514.598	1.884
Ref. line (right) 3	523.3	535.654	2.3063
Ref. line (right) 4	497.5	505.371	1.5574
Ref. line (right) 5	507.4	513.912	1.2671
Ref. line (right) 6	539.2	546.209	1.2832

TPS: Treatment planning system

new Varisource was used in this code during the evaluation. A screenshot of the software can be seen in Figure 3. Input data required by the software code can be taken from the plan report generated by the TPS (such as dwell position and calculation point coordinate, dwell time at each dwell position, AKS on the date of treatment, and TPS calculated dose at the dose calculation point). It subsequently calculates dose and

associated percentage error for the points of interest, which is used as a formal verification of the treatment dosimetry. We evaluated this software on a number of different types of clinical cases treated with Varisource HDR brachytherapy. Calculation points were selected randomly from the list of the dose points entered during the treatment planning and compared with the TPS calculated dose at that point. It is

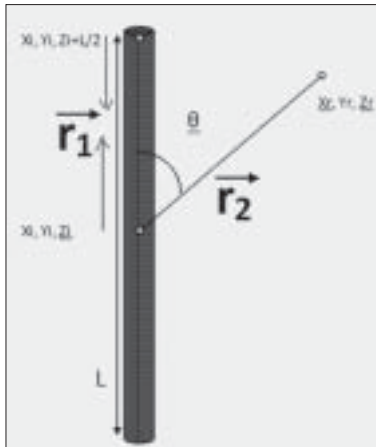

Figure 2: Schematic diagram of geometry used for calculation of r_1 and θ

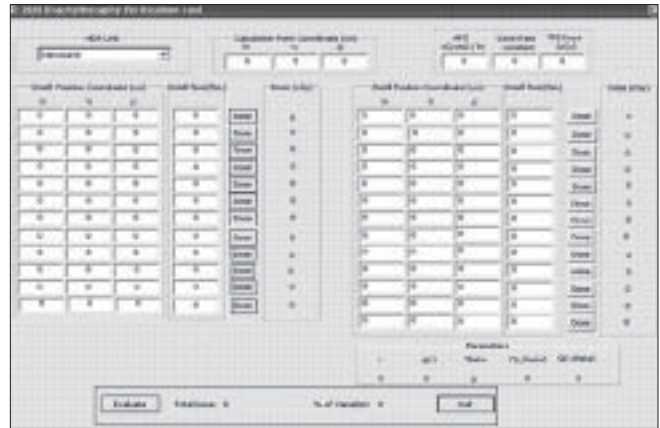

Figure 3: Screenshot of the HDR brachytherapy dose verification code

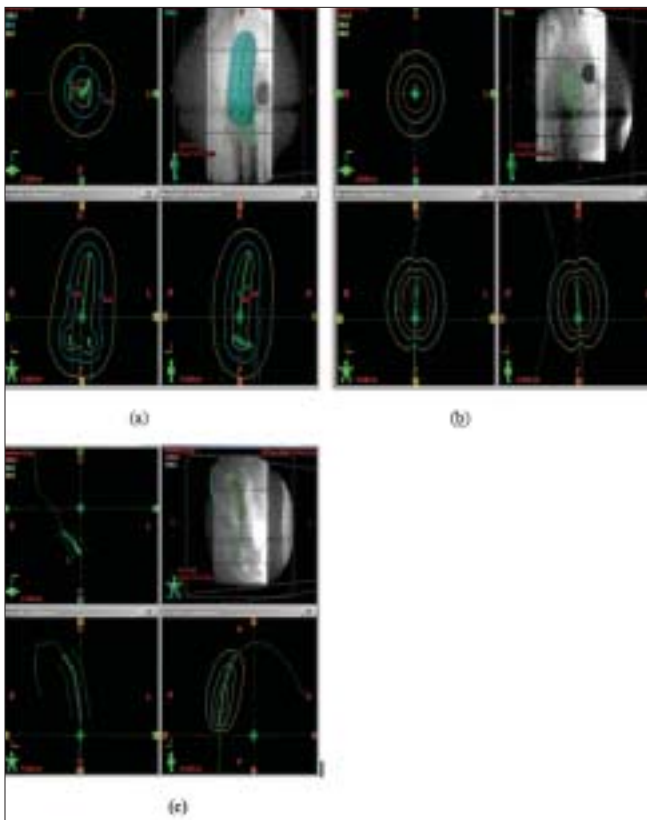

Figure 4: Screenshot of TPS showing the position of the source and dose calculation points for (a) intracavitary, (b) CVS, and (c) intraluminal brachytherapy treatment plans

notable that no correction was applied for attenuation of radiation by the applicator in this code. Figure 4 shows the visual representation of the geometrical position of the source as well as the dose calculation point of the different types of clinical cases for which the code was evaluated.

RESULTS

The code was tested for a number of clinical cases at

various positions against the TPS calculated dose values (BrachyVision, Varian Medical System, USA) for the Varisource. Table 3a shows the TPS and verification code calculated dose values and their percentage deviation for intracavitary brachytherapy treatment plans. The data in this table indicate that the percentage variation between the TPS calculated dose and verification code calculated dose is of the order of 2%. Table 3b shows the TPS and verification code calculated dose values and their percentage deviation for central vaginal source (CVS) brachytherapy treatment plans. Percentage deviations for CVS quoted in this table are within 1% for most of the points, except for one point where the deviation is about 2.4%. Table 3c shows TPS and verification code calculated dose values and their percentage deviation for intraluminal brachytherapy treatment plans. Percentage deviations for intraluminal brachytherapy quoted in this table are within 1.5% for most of the calculation points, except at few points where the deviation is up to 2.3%. Table 3a–c indicate that the variation in the TPS calculated dose and verification code calculated dose values is less than 1.5% at most of the evaluation points. Based on these observations, one can conclude that the TPS calculated dose values and verification code calculated dose values for the different clinical cases considered here are in good agreement (to within 3%) at most of the points of clinical importance.

DISCUSSION

Pretreatment dose verification is an important aspect of patient-specific quality assurance. A simple, fast, and accurate method of dose verification is required to fulfil this requirement. The AAPM TG-43 formalism-based verification code described here is a quick and simple method to check the dose calculation by the TPS. It can be used for verifying the accuracy of dose calculations during the commissioning of the TPS and, subsequently, for periodical quality control checks. Checking the dose calculation for each and every patient ensures the accuracy of dose delivery and the safety of the patients during brachytherapy treatments. Though the

method is tested for the Varisource HDR brachytherapy source, it is a general verification method which can be applied for verifying the treatment plans of other HDR brachytherapy sources. Even though the accuracy of dose calculation of TPS is fully verified during commissioning and, subsequently, during periodic quality control tests, checking the dosimetry prior to each treatment ensures that the correct source data is being used and that the source data has not been modified by software bugs either deliberately or incidentally. It is important to note here that the basic source data required for dose calculation by the verification code is entered into the computer independently and has no direct link with the data presented by the commercial planning system. This way the present code provides confidence to the user against any malfunction of the commercial TPS as the decay correction of the source is accounted for by the planning software automatically.

CONCLUSION

The code independently verifies the dose calculated by the TPS at selected points for HDR brachytherapy using AAPM TG-43 parameters. The code is written to work with Varisource, but it can conceivably be modified for other sources also by using the fitted constant of the respective source.

ACKNOWLEDGMENT

We are thankful to Dr Y.S. Mayya, Head, RP and AD and Shri H.S. Kushwaha, Director, HS and EG, BARC for their encouragement and interest in this work.

REFERENCES

1. Atomic Energy Regulatory Board (AERB). Safety Code for Medical Applications of Ionizing Radiation, AERB SC-MED 1 and 3, 2007. (Yet to be adopted)
2. Nath R, Anderson LL, Luxton G, Weaver KA, Williamson JF, Meigooni AS. Dosimetry of interstitial brachytherapy sources: Recommendations of the AAPM Radiation Therapy Committee Task Group No. 43. *Med Phys* 1995;22:209-34.
3. Lliso F, Pérez-Calatayud J, Carmona V, Ballester F, Puchades V, Granero D. Technical note: Fitted dosimetric parameters of high dose-rate 192Ir sources according to the AAPM TG43 formalism. *Med Phys* 2003;30:651-4.
4. Rivard MJ. Refinements to the geometry factor used in the AAPM Task Group Report No 43 necessary for brachytherapy dosimetry calculations. *Med Phys* 1999;26:2445-50.
5. Angelopoulos A, Baras P, Sakelliou L, Karaiskos P, Sandilos P. Monte Carlo dosimetry of a new 192Ir high dose rate brachytherapy source. *Med Phys* 2000;27:2521-7.

Source of Support: Nil, **Conflict of Interest:** None declared.

Author Help: Sending a revised article

- 1) Include the referees' remarks and point to point clarification to those remarks at the beginning in the revised article file itself. In addition, mark the changes as underlined or coloured text in the article. Please include in a single file
 - a. referees' comments
 - b. point to point clarifications on the comments
 - c. revised article with text highlighting the changes done
- 2) Include the original comments of the reviewers/editor with point to point reply at the beginning of the article in the 'Article File'. To ensure that the reviewer can assess the revised paper in timely fashion, please reply to the comments of the referees/editors in the following manner.
 - There is no data on follow-up of these patients.
Authors' Reply: The follow up of patients have been included in the results section [Page 3, para 2]
 - Authors should highlight the relation of complication to duration of diabetes.
Authors' Reply: The complications as seen in our study group has been included in the results section [Page 4, Table]