

# Assessment of the Optimization Strategy for Nitrogen Cooling Channel Design in Extrusion Dies

Riccardo Pelaccia<sup>1,a\*</sup>, Marco Negrozio<sup>2,b</sup>, Barbara Reggiani<sup>3,c</sup>  
and Lorenzo Donati<sup>4,d</sup>

<sup>1</sup>DISMI- Department of Sciences of Methods for Engineering, University of Modena and Reggio Emilia, Viale Amendola 2, 42124, Reggio Emilia, Italy

<sup>2</sup>DIN- Department of Industrial Engineering, University of Bologna, Viale Risorgimento 2, 40136, Bologna, Italy

<sup>a</sup>riccardo.pelaccia@unimore.it, <sup>b</sup>marco.negozio2@unibo.it, <sup>c</sup>barbara.reggiani@unimore.it,  
<sup>d</sup>l.donati@unibo.it

**Keywords:** extrusion, multi-objective optimization, optimization strategy, nitrogen cooling, NSGA-II algorithm, meta-models

**Abstract.** Aluminum extrusion is an efficient industrial process. However, one of the main problems is related to the temperatures developed during the process that can detrimentally affect the achievable productivity, profile quality and/or die life. Cooling of the die with liquid nitrogen represents an efficient solution to overcome these limits but a further issue arises lying in the number of process and design variables that need to be managed in order to set-up of an efficient system. In this context, a 3D FE model of the extrusion process, coupled with a 1D model of the cooling channel, previously proposed by the authors, has been integrated in an optimization platform in order to iteratively and automatically adjust the channel geometry and the process variables gaining to a final optimal solution in terms of thermal balance, cooling efficiency and nitrogen consumption. The original channel design used during the extrusion of industrial hollow AA6060 profile guaranteed an efficient but unbalanced cooling with a maximum temperature deviation of 60 °C registered by the thermocouple positioned around the bearings. The optimized designs showed temperature deviations below the 16 °C as well as the reduction of 50% in terms of nitrogen consuming.

## Introduction

The use of liquid nitrogen during the hot extrusion process is one of the most adopted industrial solutions used to reduce the die heating as well as to avoid surface defects on the final profile caused by high temperatures [1-2]. The nitrogen flows in a cooling channel that is manufactured in the backer surface in contact with the die by means of chip removal processes (milling and drilling). Within the die, liquid nitrogen subtracts heat from the die and, indirectly, from the profile; at the channel exit, nitrogen is in a gaseous state and surrounds the profile surface reducing oxidation [3].

Despite the diffuse use of liquid nitrogen in the industrial context and its proved effectiveness [4-6], a systematic methodology for the design of the cooling channel has not yet been proposed. The cooling channel are still designed based on die-makers experience, even if many parameters, which strongly affects the cooling performances, are involved in the fluid-dynamic of the nitrogen flow [7-8]: position and geometry of the channel, inlet nitrogen parameters, nitrogen phase-change along the cooling path, thermal properties of the die among others. This level of complexity can be more properly managed by means of numerical models and necessary demands for automatic, robust and comprehensive methodologies.

The authors of the paper have still proposed a numerical model for the thermal field prediction during the extrusion process, modelled as 3D, with nitrogen flowing in a simplified 1D channel [9-11]. These works provided the basis for the present paper, in which the FE model of the cooled extrusion process was integrated within the optimization platform, modeFRONTIER®, with the aim to automatically detect the optimal channel design.

The experimental data and the numerical simulations of the selected industrial case proved the cooling effectiveness of the original channel design but also the unbalance of the thermal gradient around the bearings and the non-optimal handling of nitrogen consuming, thus offering a suitable test case.

Ten portions of the channel were set as input variables in the optimization platform, together with the inlet nitrogen pressure. The objective functions were the minimization of the thermal gradient nearby the bearings and of the nitrogen flow rate in order to reduce the consumption. Output results were evaluated in terms of Pareto front in order to select the optimal solution. Two different optimization strategies were tested and compared for the re-design of the cooling channel, without and with meta-modeling (response surface models).

### Experimental Procedure and Numerical Model Validation

The experimental campaign and the validation of the numerical model implemented within the COMSOL Multiphysics for the selected case of Fig.1 were presented in detail during the ESAFORM 2021 Conference [11]. Therefore, only the main data are here synthetically recalled for the sake of clarity of the present work.

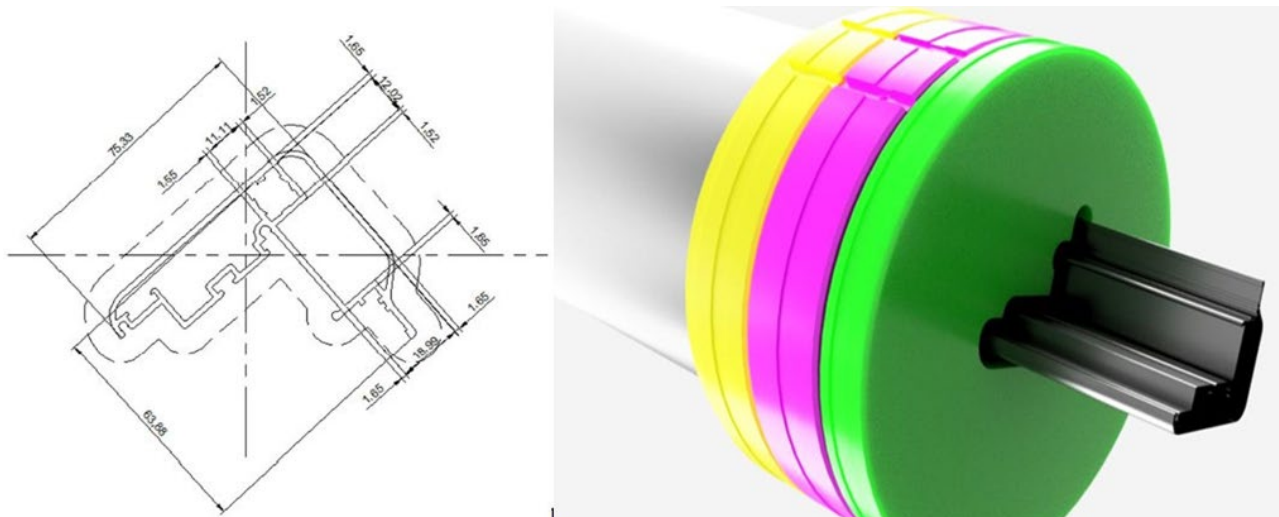

Fig. 1 The industrial hollow profile

Three parts compose the tooling set (Figs.2,3): the mandrel, with two holes for the thermocouples in the proximity of the welding chamber (T2 and T4), the die, with three thermocouples nearby the bearings zones (T1,T3,T5), the backer, with the planar cooling channel. At the end of the cooling path, the nitrogen was directed towards the profile surface by means of eleven transferring holes drilled in the die (Fig.3).

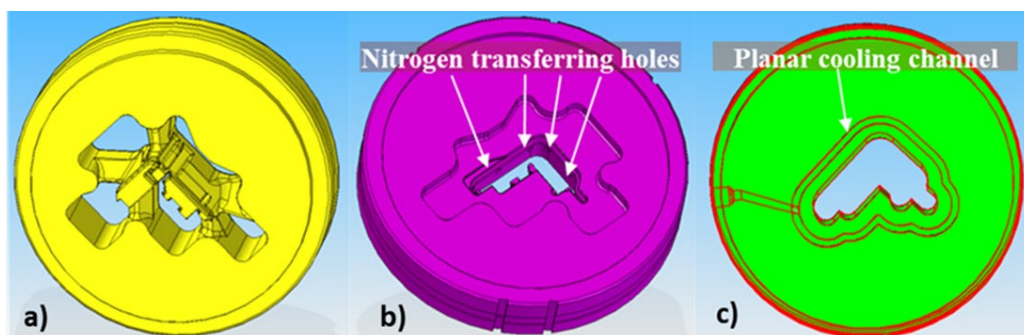

Fig. 2 The tooling set: a) the mandrel; b) the die; c) the backer [11]

Ten AA6060 billets were extruded at 2.71 mm/s of ram speed, as showed in Fig.4: the first sixth billets were processed without the nitrogen cooling, the 7<sup>th</sup> and the 8<sup>th</sup> billets were extruded using the

100% of nitrogen flow rate, while during the last two extrusion the nitrogen flow rate was significantly reduced (30% and 20% respectively).

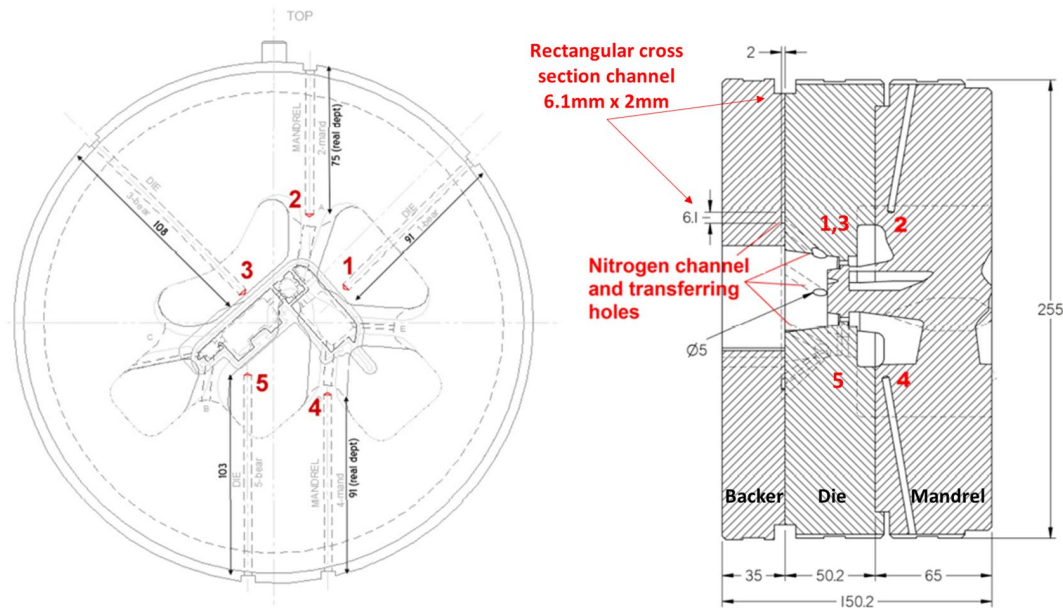

Fig. 3 The thermocouple positioning [11]

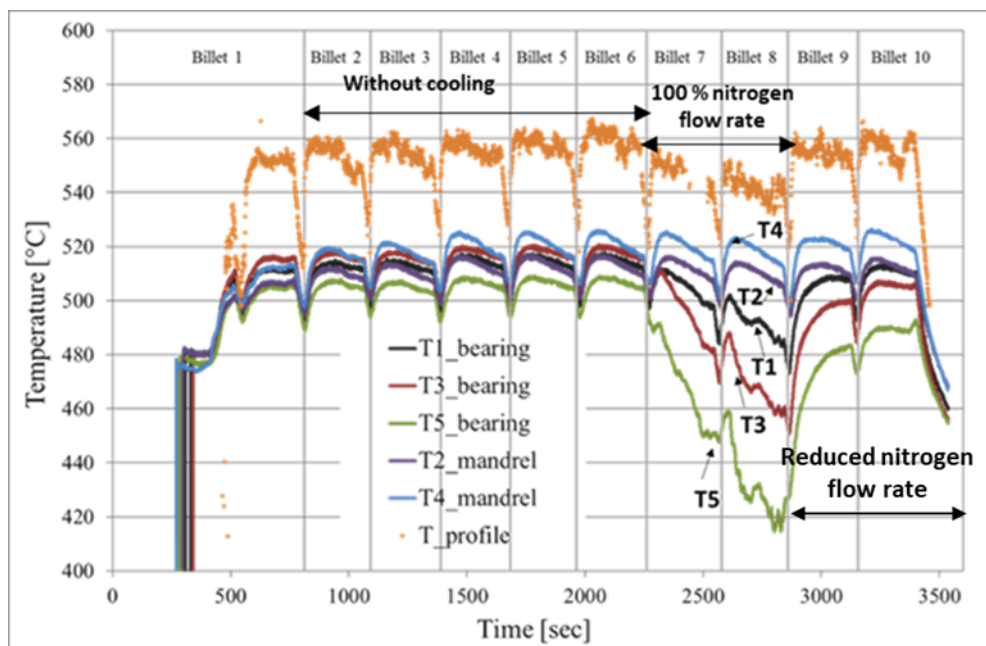

Fig. 4 Temperature history of the process in the tooling set and in the exit profile [11]

The experimental results evidenced a high cooling when the nitrogen valve was fully opened (billet 8), obtaining a peak temperature decrease of 80 °C in T5. In addition, the cooling effectiveness was negligible in the mandrel (T2 and T4), thus not affecting the billet deformability within the welding chamber. However, the cooling resulted unbalanced around the bearings with a maximum T1-T5 difference of 60 °C, promoting profile distortion and significantly stressing the die due to the differential cooling. In addition, the nitrogen valve fully opened ensures in this case a nitrogen flow rate of 8.7 l/min that could be reduced. Moreover, the cooling performances were drastically reduced with lower nitrogen flow rate (billets 9,10), thus negatively affecting the nitrogen handling and consuming.

Concerning the numerical model, the 1D model of the cooling channel was integrated with the 3D Eulerian model of the extrusion process (Fig.5) [9-12] in order to test the different meaningful experimental conditions (no cooling, 100% and 20% of nitrogen flow rate). The hot aluminum was

treated as a fluid with high viscosity depending on the shear rate and temperature [13], thus selecting the Sellars-Tegart inverse sine hyperbolic law to model the flow stress [14]. In the contact areas between the billet and the tooling set, a sticking friction condition was generally imposed, while in the bearing zones the slip friction condition was used. The nitrogen phase change was not considered in the model and the physical properties of the liquid nitrogen were implemented [15].

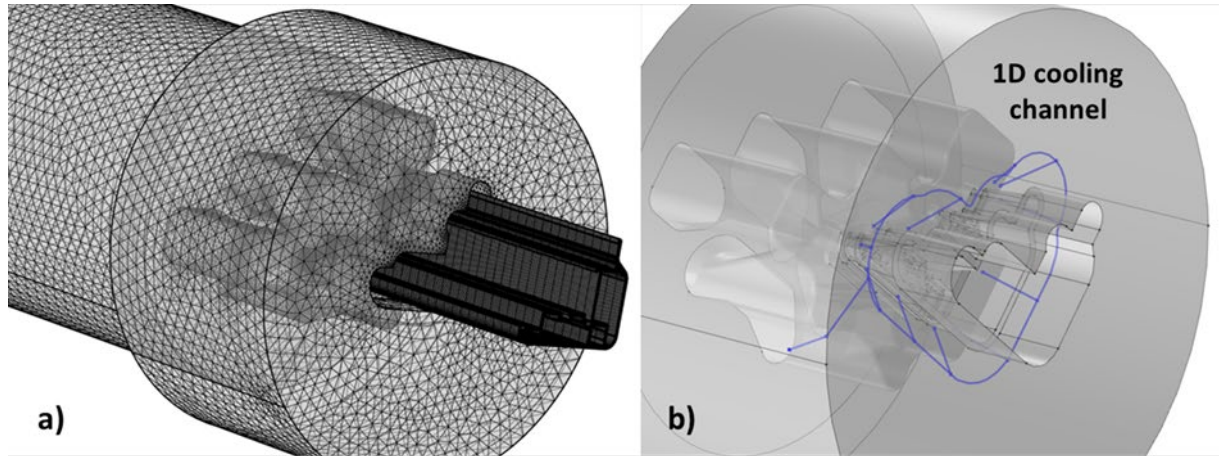

Fig. 5 FE model: a) The billet and the tooling set (1512663 tetrahedral elements); b) The 1D cooling channel integrated in the tooling set (380 edge elements) [11]

Table 1 summarizes the boundary conditions and the process parameters used for the steady-state simulations, while Figs. 6,7 show the thermal fields resulting from the simulated extrusion conditions.

Table 1 Process Parameters and boundary conditions set in the numerical models

Process Parameters	Value
Billet Temperature	460 [°C]
Die Temperature	500 [°C]
Container Temperature	427 [°C]
Ram Temperature	413 [°C]
Ram Speed	2.71 [mm/s]
Aluminum-Steel Heat Transfer Coefficient	11,000 [W/m <sup>2</sup> °K]
Steel-Steel Heat Transfer Coefficient	3000 [W/m <sup>2</sup> °K]
Inlet Nitrogen Temperature	-200 [°C]
Nitrogen flow rate	0%, 20%, 100% (0, 1.8, 8.7 [l/min])
Nitrogen density $\rho$	806.59 [kg/m <sup>3</sup> ]
Nitrogen heat capacity at constant pressure $C_p$	$C_p(T,P)$
Nitrogen thermal conductivity $k$	$k(T,P)$

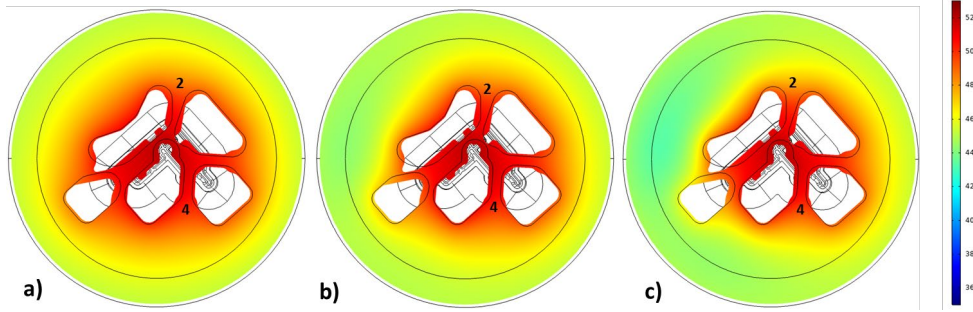

Fig. 6 Thermal field in the thermocouple plane of the **mandrel**: a) Uncooled process; b) 20% of nitrogen flow rate; c) 100% of nitrogen flow rate

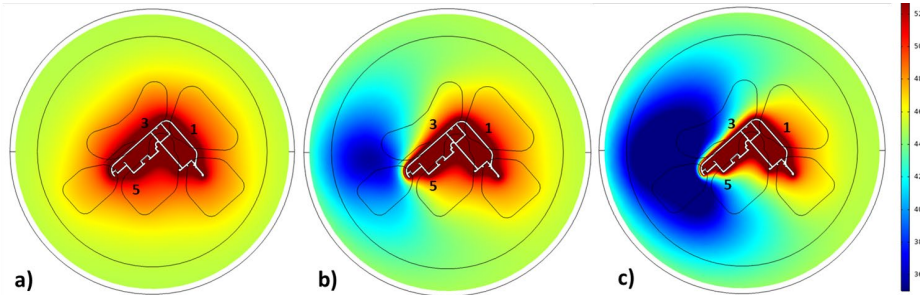

Fig. 7 Thermal field in the thermocouple plane of the **die**: a) Uncooled process; b) 20% of nitrogen flow rate; c) 100% of nitrogen flow rate

In the mandrel (Fig.6), the thermal maps were comparable in all extruded conditions, evidencing the cooling effectiveness only nearby the bearings zones, as observed in the experiments.

In the die (Fig.7), the cooling was effective with the 100% of nitrogen flow rate, as clearly indicated by the blue zone around the bearings (Fig.7c). However, the unbalancing of the cooling was evident especially in the area of T1 where the red color is associated with temperatures of about 500°C, values almost comparable with the uncooled ones. In addition, it was possible to appreciate the low cooling efficiency with the 20% of the nitrogen flow rate (Fig.7b).

Table 2 shows the experimental-numerical comparison in terms of temperature prediction: the uncooled condition was compared with the extrusion of billet 6, the cooled condition with 100% of nitrogen flow rate with billet 8, and the condition with 20% of nitrogen flow rate with the last extrusion. A peak error of -2.8% was detected in T4 for the uncooled condition, of 3.9% in T1 and -3% in T2 for the cooled conditions with 100% and 20% of nitrogen flow rate, respectively.

Table 2 Experimental-Numerical comparisons in terms of temperature prediction: no cooling Billet 6; 100% of nitrogen flow rate Billet 8; 20% of nitrogen flow rate Billet 10

	Thermocouples Temperature [°C]					Profile Exit T [°C]	Cooling
	T1	T2	T3	T4	T5		
<b>Exp. Billet 6</b>	518	517	520	525	510	560	NO
<b>Num. Billet 6</b>	530	505	530	510	523	563	NO
<b>Err%</b>	2.3	-2.3	1.9	-2.8	2.5	-0.7	
<b>Exp. Billet 8</b>	490	508	460	523	430	540	YES
<b>Num. Billet 8</b>	509	500	450	505	430	550	YES
<b>Err%</b>	3.9	-1.6	-2.2	-3.5	0	+1.9	
<b>Exp. Billet 10</b>	510	517	508	525	490	560	YES
<b>Num. Billet 10</b>	520	500	510	510	495	558	YES
<b>Err%</b>	2.0%	-3.3%	0.4%	-2.9%	1.0%	-0.4%	

With respect to the previous work [11], in which the balancing of the cooling was manually attempted testing different re-design in the COMSOL environment, in the present one the numerical model was integrated within the optimization platform in order to change the channel design in an automatic way guided by a selected genetic algorithm.

### Workflow Structure Design within the Optimization Platform

The COMSOL environment was integrated in the modeFRONTIER® workflow [16] by means of a DOS batch node connected to the input file of the FE model in order to update the channel design at each simulation run (Fig.8). In the upper part of the workflow, the green icons represent the input variables, while the blue icons in the bottom are the outputs connected to the objective functions' nodes. The input variables are automatically selected and updated in the input file of the FE model at each run, while the outputs and the results of the objective functions are generated in the .txt file and inserted in the table inside modeFRONTIER for the subsequent analysis of the results.

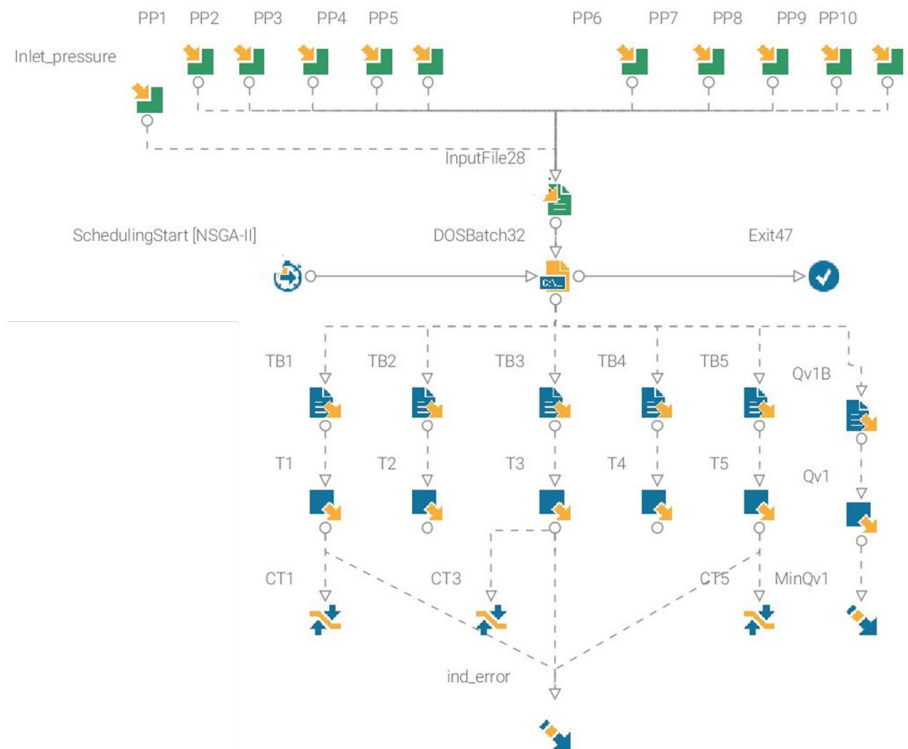

Fig. 8 Mode FRONTIER ® workflow used in the channel design optimization

Two objective functions were selected for the optimization. The first one (*ind\_error*), imposed by Eq. (1), was aimed at balancing the temperature around the bearings (T1, T3, T5):

$$ind\_error = \sqrt{\frac{(T1-450)^2 + (T3-450)^2 + (T5-450)^2 + (T1-T3)^2 + (T1-T5)^2 + (T3-T5)^2}{6}} + (1.01^{T1-450} - 1)^2 + (1.01^{T3-450} - 1)^2 + (1.01^{T5-450} - 1)^2 \quad (1)$$

The first term of the equation under the square root drives the algorithm towards the thermal balance and the target temperature of 450°C. The other terms force the algorithm to prefer colder solutions (e.g: the solution with T1, T2 and T5 at 400 °C is preferred to the one with all values at 500°C). The target temperature of 450 °C was selected to avoid thermal shocks in the die as well as to prevent an excessive drop of temperature in the exit profile.

The second objective function was the minimization of the nitrogen flow rate in order to find a channel design that reduces the nitrogen consumption.

The channel was divided into 10 segments within the COMSOL model (Fig. 9) in order to set the channel heights along the cooling path as input variables for the optimizer. In addition, the nitrogen inlet pressure was selected as input variable to analyze the nitrogen flow rate as a function of both channel design and valve opening.

Based on the author's experiences, the channel height was allowed to vary in the range from 1 mm to 10 mm, avoiding an excessive reduction of the backer resistance, while the channel width remained constant (6.1 mm), thus varying the hydraulic diameter of the 1D channel from 1.7 mm to 7.5 mm in the planar path. In the same way, the diameter of the transferring holes was varied between 2.5 mm to 6 mm. The nitrogen inlet pressure was set variable in the reasonable range for industrial nitrogen plants (1.5-4 bars).

The five thermocouples' temperature and the nitrogen flow rate were selected as outputs and saved in the design table at each run.

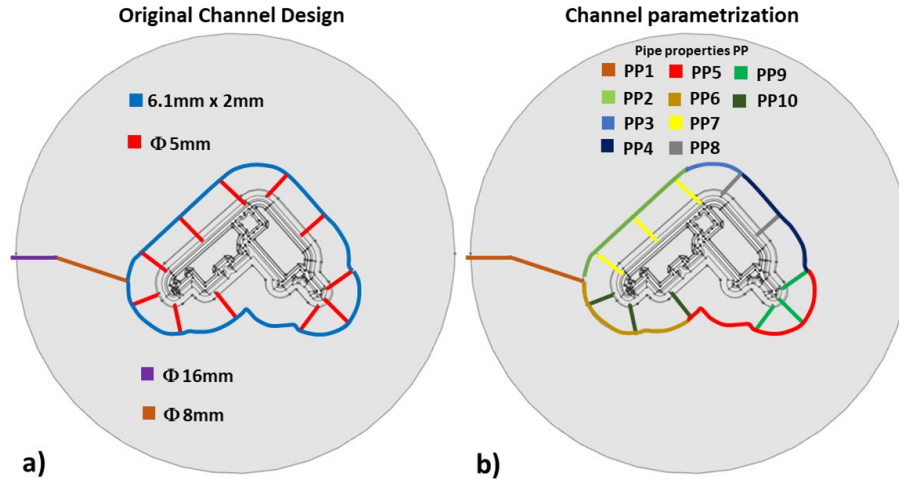

Fig. 9 Channel height parametrization along the cooling path: a) Original channel design; b) Channel divided into 10 parts

Two different optimization strategies were proposed and compared: in the first approach, 100 designs were generated using a genetic algorithm and automatically simulated by COMSOL, whilst, in the second approach, a meta-model was generated from an initial DOE of 100 design and then used to test a large number of designs without using the FE model.

The algorithm used to solve the first optimization strategy was the Non-dominated Sorting Genetic Algorithm (NSGA-II) implemented in modeFRONTIER [16] with an initial population of 10 configurations identified with three different strategies: a random DOE sequence, a Pseudo-Random Sobol DOE sequence and the Uniform Latin Hypercube DOE sequence (ULH). The number of generations evaluated was set to 10, while a mutation rate of 0.01 and a uniform crossover method with a 0.9 crossover rate were used. A total of 100 designs (initial population\*number of generations) were evaluated in 12 hours (laptop with Intel® core™ processor i7-7700HQ and Ram 16GB).

In the second strategy, starting from a Sobol DOE sequence of 100 tested designs, multiple response surfaces (RS) were created, one for each output variable, using the radial basis function (RB) interpolation tool. Then, the meta-models obtained were used with the NSGA-II algorithm generating 10.000 design (100 initial design\*100 generations) in less than 2 minutes.

### Numerical results of the optimization procedures and selection of the new channel design

The optimization algorithm NSGA-II was tested varying the DOE sequence generation by testing the random, the Sobol and the ULH sequences, the last two selected in order to reduce the clustering effect by a reduced and uniform sampling.

The outputs of each simulation run were automatically saved in a table inside the optimization project allowing to generate different "design charts" to analyze the results.

Fig.10 summarizes the results of the optimization procedure using the Sobol DOE sequence in a bubble chart of the 4D design space, where the channel designs (bubbles) are plotted in a nitrogen flow rate (x-axis) - temperature deviation index (ind\_error of eq(1)) (y-axis) graph. In addition, the diameter of the bubbles is related to the temperature of T1 that recorded the maximum temperature in the original design, while the color of the bubbles represents the temperature of T5 that recorded

instead the minimum temperature. The design positioned around the origin of the axis guaranteed solutions with thermal balance around the bearings and reduced nitrogen flow rate.

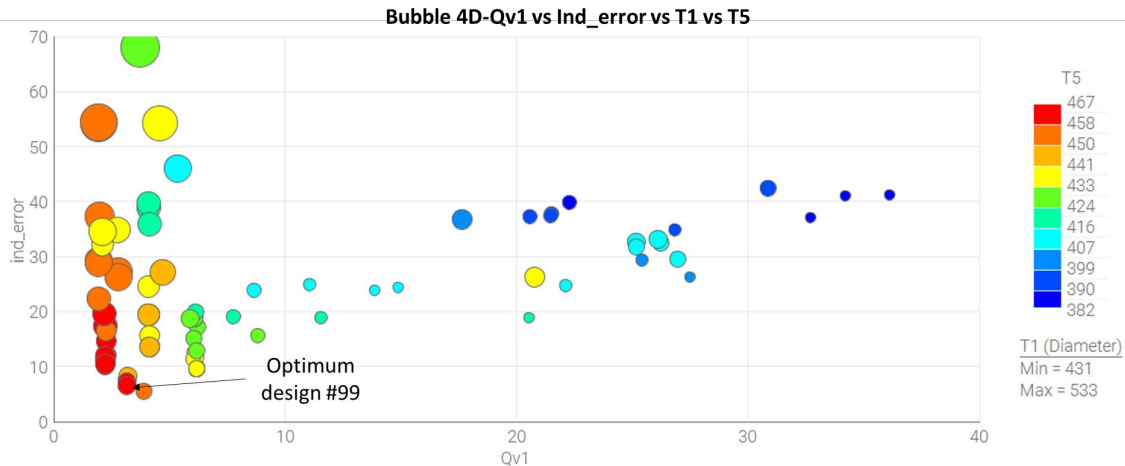

Fig. 10 Optimization results in the 4D design space using Sobol DOE sequence

For the selection of the optimal design, the linear *Multiple-Criteria Decision-Making* (MCDM) was used, selecting the weight of each objective function to obtain the design ranking. In this case, the same value of 0.5 was chosen for both the cooling balancing and the minimization of the nitrogen flow rate.

In the Pareto front, as the result of the optimization with Sobol DOE sequence, the selected channel design (# 99) showed a temperature deviation index (ind\_error) of 6.71 using a nitrogen flow rate of 3.13 l/min, value lower than the 6 l/min obtained with the original design. In terms of cooling balancing, the temperature value of the three thermocouples around the bearings was 458°C, 453°C and 460°C respectively for T1, T3 and T5. In detail, Table 3 reports the temperature and nitrogen flow rate comparison between the three optimizations and the original design.

Table 3 Comparison between the original design and the design derived by the optimization

	#design	T1 [°C]	T3 [°C]	T5 [°C]	Ind_error	Qv [l/min]
<b>Original numerical design (100% nitrogen flow rate)</b>		509	450	430		8.7
<b>Random DOE/NSGA-II</b>	95	462	454	436	15.85	4.22
<b>Sobol DOE/NSGA-II</b>	99	458	453	460	6.71	3.13
<b>ULH DOE/NSGA-II</b>	95	464	478	456	17.27	2.24

All three optimizations showed designs with good temperature balancing and reduced nitrogen flow rate if compared to the original design. However, the best solution was detected by the optimization started from the Sobol DOE with the minimum temperature deviation index and with the reduction of about 60% in terms of nitrogen consumption. In addition, it can be noticed that the solutions proposed with the Random and the ULH DOE were comparable in terms of temperature deviation, but the index value for the first one was lower since, as previously explained, a colder solution is preferred (436°C vs 478°C with a control value of 450°C).

The second optimization strategy started with the test of 100 designs generated by the Sobol sequence that were used by modeFRONTIER to train meta-models as relations between the input variables and the output results generated using the radial basis function (RB) interpolation tool. The meta-models were used to test 10000 designs (100 initial design\*100 generation) in a very short time without the use of the FE model node.

Fig. 11 reports the bubble chart of the 4D design space obtained with the meta-models. For the selection of the optimal design, the linear MCDM was used neglecting the unfeasible designs (i.e. those with negative nitrogen flow rate). For the same reason, in the Fig.11 the area of the unfeasible designs in the chart was truncated.



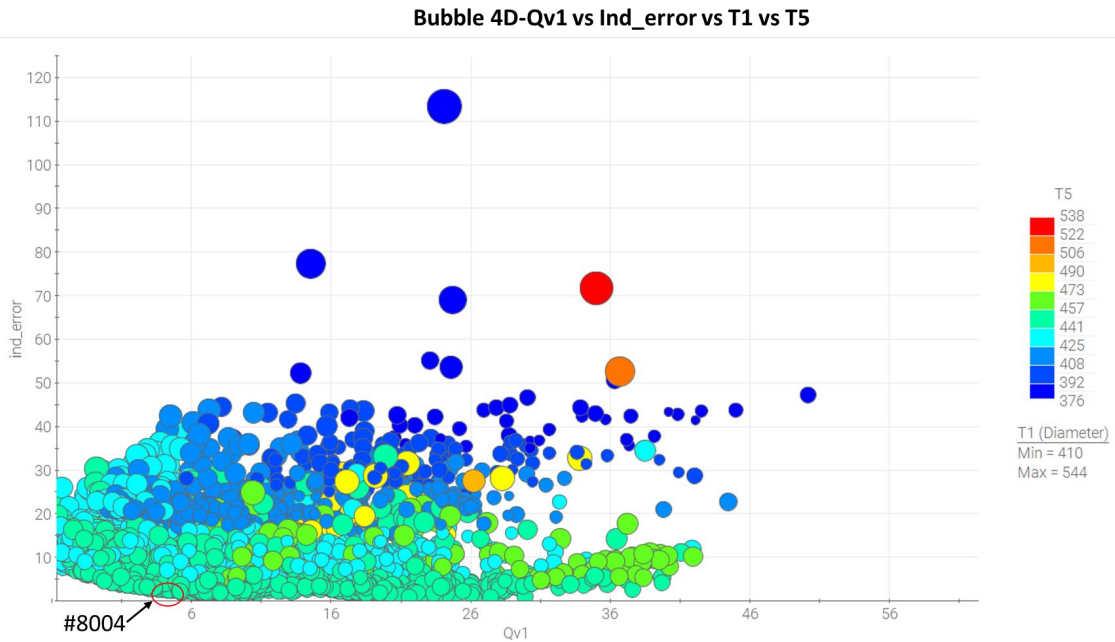

Fig. 11 Optimization results in the 4D design space using meta-models

In the Pareto front, the selected channel design (# 8004) showed the temperature deviation index (ind\_error) of 2.77, a nitrogen flow rate of 3.7 l/min, temperature values of 453°C, 449°C and 448°C respectively for T1, T3 and T5. The selected design was then evaluated in COMSOL in order to test the reliability of the solution generated by the meta-models. Table 4 reports the comparison between the FE model and the meta-model results, evidencing the good matching in terms of temperature and nitrogen flow rate predictions (peak error -13.5%).

Table 4 Comparison between the meta-models and FE model results in terms of temperature and nitrogen flow rate prediction

	#design	T1 [°C]	T3 [°C]	T5 [°C]	Ind_error	Qv [l/min]
<b>Meta-models</b>	8004	453	449	448	2.77	3.7
<b>Comsol FE model</b>	8004	466	450	455	10.37	3.2
<b>Err%</b>		2.9%	0.2%	1.6%		-13.5%

The solution achieved by means of the second strategy with meta-models apparently seemed better than the first one in terms of thermal balancing around the bearings. However, testing the selected design with the FE model it should be noted that the temperature deviation was comparable with the solution obtained with the first optimization strategy (Sobol DOE/NSGA-II). Improve the accuracy of the meta-models in terms of temperature prediction could lead to increase the potentiality of this second optimization strategy that allows the testing of a large number of configurations in a very short computation time.

### Comparison between the Original Design and the New Cooling Channel Designs

Fig.12 shows the comparison between the original design and the optimal designs achieved with the two optimization strategies (Sobol DOE sequence and meta-models). In addition, Fig.13 reports the thermal field around the bearings by comparing the original design performances with the optimized ones. The area around the three thermocouples was cooled in an efficient and comparable way using the two new designs, confirming the achievement of the optimization procedure. In terms of nitrogen consuming a reduction of about 60% was gain with both optimized designs.

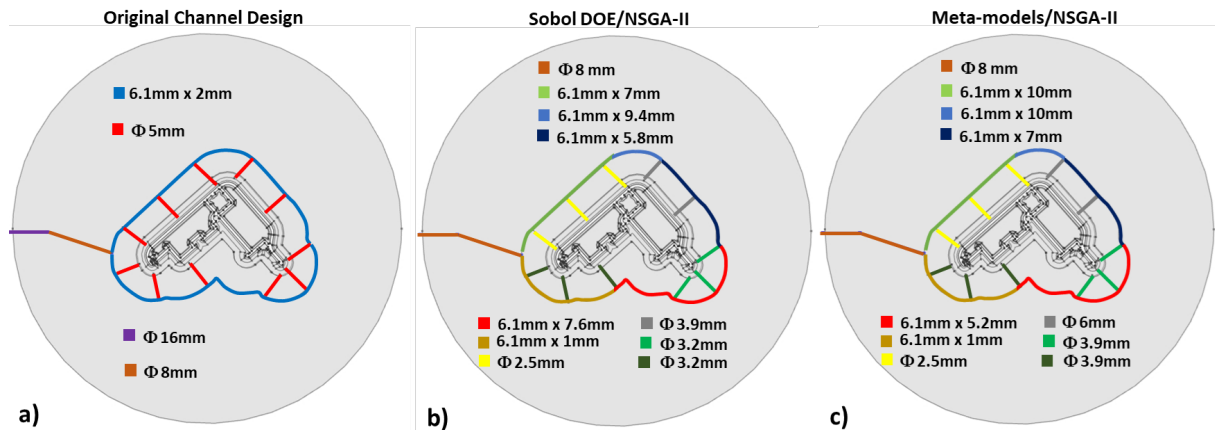

Fig. 12 Geometrical dimension of channel designs: a) original design; b) Sobol DOE/NSGA-II design; c) Meta-Models/NSGA-II design

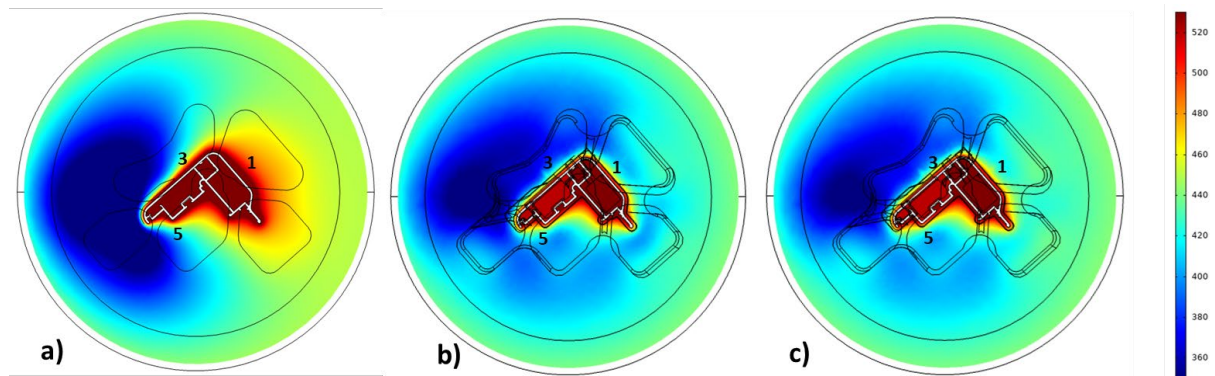

Fig. 13 Thermal field in the thermocouple plane of the die: a) Original design b) Sobol DOE/NSGA-II design c) Meta-Models/NSGA-II design

## Conclusions

In the present work, a comprehensive procedure for the multi-objective optimization of cooling channel design in extrusion dies has been presented and tested against an industrial case study that experimentally showed an efficient but unbalanced nitrogen cooling around the bearings zones.

Two different optimization strategies were assessed by imposing the thermal balance around the bearings and the reduction of the nitrogen consumption as objective functions: the use of genetic algorithm NSGA-II to generate 100 optimal designs starting from an initial population of 10 design, and the use of meta-models generated with an initial population of 100 training designs to test, with the same NSGA-II algorithm, 10000 designs without the use of FE model node. The opportunity to perform an extensive investigation in the optimum design space constitutes the principal benefit of adopting these procedures.

For the selected test case, the automatic and iteratively investigation of 100 channel geometry and process variable configurations required 12 hours to solve the FE models with the first optimization strategy. By using the meta-models, 10000 designs were evaluated in 12 hours for the training with the FE model plus only 2 minutes to test all the remaining configurations, thus perfectly matching with the requirement of supporting the die design phase in an industrial framework.

The efficient investigation of the optimization design space allowed identifying and selecting solutions that led to a significant improvement of the cooling balancing around the bearings as well as to the reduction of the nitrogen consumption, obtaining temperature differences below 16°C in all selected configurations and the reduction of about 60% in terms of nitrogen flow rate.

The accuracy of the meta-models was proved by comparing the cooling efficiency expected against the FE model simulation results: errors below 2% in terms of temperature prediction and 14% in terms of nitrogen flow rate were obtained with the meta-models.

In conclusion, the proposed approach for the cooling channel design should be considered as a robust, flexible and reliable tool at the die design stage in order to achieve the desired results such as a targeted and balanced cooling. Points of interest for future development are the testing of different optimization algorithms, the assessment of the influence of both initial and total tested designs as well as the implementation of different objective functions.

## References

- [1] P.K. Saha, Aluminum extrusion technology, ASM International, Materials Park, OH, USA, 2000.
- [2] T. Sheppard, Extrusion on Aluminum Alloys, Kluwer Academic Publisher, 1999.
- [3] A.F. Ciuffini et al., Surface Quality Improvement of AA6060 Aluminum Extruded Components through Liquid Nitrogen Mold Cooling, *Metals*, 8 (2018).
- [4] T.J. Ward, R.M. Kelly, G.A. Jones, J.F. Heffron, The effects of Nitrogen - liquid and gaseous - on aluminum extrusion productivity, *JOM - The Journal of The Minerals, Metals & Materials Society*, vol. 36, pp. 29-33, 1984.
- [5] P. Stratton, Raising productivity of aluminium extrusion with nitrogen, *International Heat Treatment and Surface Engineering*, 2 (2008) 105-108.
- [6] L. Donati, A. Segatori, B. Reggiani, et al, Effect of liquid nitrogen die cooling on extrusion process conditions, *Key Engineering Materials*, 491 (2012) 215-222.
- [7] A.J. Norwood, et al., Analysis of cooling channels performance, *International Journal of Computer Integrated Manufacturing*, 17 (8) (2004) 669 – 678.
- [8] M.V. Lurie, Modeling of Oil Product and Gas Pipeline Transportation, WILEY-VCH Verlag GmbH & Co., KGaA, Weinheim, 2008.
- [9] B. Reggiani, L. Donati, Prediction of liquid nitrogen die cooling effect on the extrusion process parameters by means of FE simulations and experimental validation, *Journal of Manufacturing Processes*, 41 (2019) 231-241.
- [10] R. Pelaccia, M. Negozio, L. Donati, B. Reggiani, L. Tomesani, Extrusion of Light and Ultralight Alloys with Liquid Nitrogen Conformal Cooled Dies: Process Analysis and Simulation, *Journal of Materials Engineering and Performance*, (2021).
- [11] R. Pelaccia, M. Negozio, B. Reggiani, L. Donati, L. Tomesani, Analysis and optimization of cooling channels performances for industrial extrusion dies, *ESAFORM 2021: Proceedings of the 24th International Conference on Material Forming* 3686:1-11. Liège, Belgique. <https://doi.org/10.25518/esaform21.368>
- [12] COMSOL® Multiphysics (Version 5.4). Modelling software; <https://www.comsol.it>
- [13] M. Nourani, A. S. Milani, S. Yannacopoulos, On the effect of different material constitutive equations in modeling friction stir welding: A review and comparative study on aluminum 6061, *International Journal of Advances in Engineering & Technology*, 7 (1) (2014) 1-20.
- [14] C.M. Sellars, W.J. McG Tegart, Hot workability, *Int Metall Rev*, 17(1) (1972) 1–24.
- [15] E.W. Lemmon, M.O. McLinden and D.G. Friend, Thermophysical Properties of Fluid Systems in NIST Chemistry WebBook, NIST Standard Reference Database Number 69, Eds. P.J. Linstrom and W.G. Mallard, National Institute of Standards and Technology, Gaithersburg MD, (2018).
- [16] <https://www.esteco.com/modelfrontier>.