

Simulation-Based Design of Reconfigurable Moulds for Injection Overmoulding

Nicolò Galati¹, Francesco Gherardini¹[0000-0002-9275-4314], Caterina Guaitoli² and Alberto Vergnano¹[0000-0003-0999-8869]

¹Dept. of Engineering “Enzo Ferrari”, University of Modena and Reggio E., Modena, Italy

²F.I.R. - Fabbrica Italiana Ruote, Modena, Italy

`francesco.gherardini@unimore.it`

Abstract. The injection moulding process enables the production of complex shaped parts, thanks to the accurate kinematics and the tight tolerances of the mould. This process is suitable for large batch production, leading to reduced single part costs, but involves high initial investments. The life of a mould can be increased by exploiting reconfigurable cavity inserts. So, a design method has been conceived for reconfigurable injection moulds by integrating Design for Assembly and Computer Aided Engineering techniques. From the early phases of a systematic design approach, the simulation models are configured with the different geometries as requested by design specifications. The mould inserts are designed with standard features in order to be quickly changed. A case study on a reconfigurable mould for the overmoulding of polymer wheels to be produced in different sizes is presented. The simulations with Moldex3D software are finally compared with the experimental data from the actual production.

Keywords: Computer Aided Engineering, Design for Assembly, Injection Moulding, Reconfigurable Mould.

1. Introduction

Injection Moulding (IM) is a manufacturing technology suitable to produce cost-effective and ready-to-use polymer parts, which require little to no postprocessing. However, due to the high fixed costs of the mould equipment [1], it is generally used for large production batches. In fact, the moulds are conceived as integral systems specifically designed for each part, and geometry redesign are generally very expensive or even not possible [2]. Due to the lack of flexibility of the mould equipment, IM is not suitable to address the current market demand of high product customization [3,4]. This limitation can be faced by conceiving reconfigurable moulds, capable of producing different but similar parts, by reusing most mould inserts and customizing only a few ones. So, the cost of the mould can be spread over the production of more parts.

To address this challenge, a method for the design of reconfigurable moulds with the integration of Computer-Aided Engineering (CAE) and Design for Assembly (DfA) techniques is here introduced. CAE became a reliable technique in the last decades [5-7]. In industry, the IM simulation is mainly limited to cavity filling verification and

design validation. However, preliminary simulations in the early design phases of the mould would lead to greater benefits in terms of efficiency and production quality.

DfA [8] is a widespread approach to create cost-effective assemblies with lower parts count and involving simpler assembly operations. DfA has been occasionally used for micro-mould design with replaceable cavities [9], modular mould design with reconfigurable cavity [10] and discrete pin tooling system such as the pin-cushion moulds [3,11]. DfA leads to design the mould with a reduced number of inserts, thanks to the integration of their functions over fewer ones, enabling an easier disassembly for repair or maintenance.

The present research aims to evaluate the integration of DfA and CAE techniques in a design method for reconfigurable IM moulds. As a case study, the design of a reconfigurable mould for the overmoulding of industrial wheels is presented. The wheels consist of an inner hub made in polyamide (PA), overmoulded with a thermoplastic polyurethane (TPU) coating. The mould should be reconfigurable as to produce two different sizes of the same wheel.

The paper is structured as follows: Section 2 introduces the method, Section 3 presents and discusses the case study, while Section 4 draws the concluding remarks.

2. Method

The design method for reconfigurable moulds integrates DfA and CAE techniques into the systematic approach of Pahl and Beitz [12]. It consists of five phases:

1. Product and process planning: Identification of constraints and requirements; Definition of which parts must be produced with the same mould; Definition of the design specifications of the parts and the mould.
2. Parts design: Provisional 3D models of the parts; Simulation of the cavity filling; Preliminary feasibility study; Equipment costing; Parts costing; Final 3D models and drawings of the parts; Final design of the related mould cavities; Definition of injection machine to be used; Iterative design review and cost verification.
3. Mould simulation-based design: Provisional 3D modelling of the mould; Simulation of the mould as for filling, packing, cooling and warpage analysis; DfA of the mould; Definition of the reconfigurable mould layout; Design review and cost verification.
4. Parts and mould detail design: Dimensional checks and product testing; Internal validation with reports highlighting any requests for improvement changes; Final design review; Bill of Materials (BOM) of the mould.
5. Mould optimization: Assessment of the reconfigurable mould using physical and virtual prototypes; Mould construction; Mould testing; Mould tuning; Production of a pre-series of parts.

The following contributions are fundamental in the method:

- CAE simulation, which aims to detect and evaluate the effectiveness of the designed parts and mould. CAE enables to anticipate any modifications to the early design phases, to optimize the mould cavity and its layout, and to make an early assessment of the models against historical company data.

- DfA, which leads to the definition of a layout that facilitates the mould assembly, its production as well as its reconfigurability, resulting in customised product configuration strategies.

3. Case Study and Results

The design of a reconfigurable mould for the overmoulding of industrial wheels is presented hereafter. The wheels (see Fig. 1) consist of a inner hub, made in Nylon PA6, overmoulded with a TPU Shore A 80 coating.

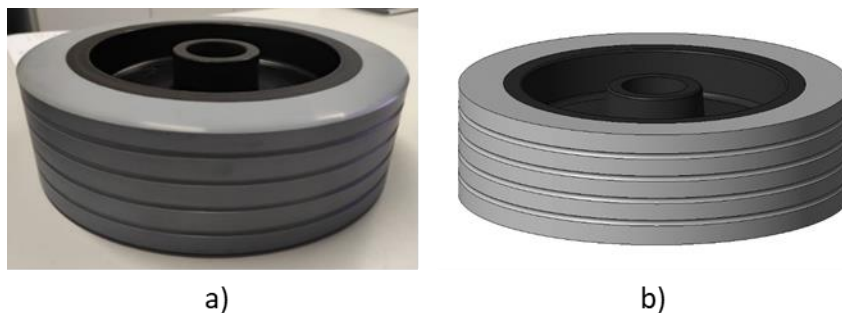

Fig. 1. A a) physical sample and its b) CAD model of one overmoulded industrial wheel.

3.1 Product and Process Planning

The constraints and requirements of the products and their reconfigurable mould are identified by the design team in collaboration with the customers. Recurring to designer experience, a sample mould is decomposed into layers considering both its stationary and its moving parts: Support plate, Lower insulating plate, Cavity inserts, Extraction plate, Ejectors, Central insert, Standard parts.

The main issues in the mould design are related with the cooling system, difficulties during the ejection phase, limited venting, mould weight and difficulties in mould handling. The reconfigurability goal of the mould is defined, identifying which wheels can be produced with the same mould equipment. Finally, the mould design specifications are refined, especially for the tolerances of the various components of each mould layer.

3.2 Parts Design

Starting from the technical specifications of the wheels, defined by the design team in collaboration with the customers, preliminary 3D part models are produced. Then, the wheels are classified in groups in order to explicit common design requirements and constraints that will be addressed by the mould reconfigurability.

In the preliminary analysis, the wheels produced by the company are grouped according to their maximum sizes (external diameter and band width) in order to properly size the mould cavities. The first group (A) consists of wheels with a diameter

of 307mm with a band width of 90mm. This size is the design constraint that defines the maximum size of the mould. The second group (B) consists of wheels with a 250mm diameter and a 50mm band width. Therefore, the mould has to be reconfigurable as to produce both these two different sizes of the same wheel.

The second analysis focuses on the central insert necessary to center the hubs to be coated. So, all the wheels produced by the company are classified according to the type of insert to be used to ensure correct centering. In fact, the central insert is made with different versions, given the customer requirements. Both A and B versions have a TPU inner hub. The IM process will be assisted by a robot that picks two hubs from a trolley and places them in the mould. After the overmoulding of the coating is completed the mould is opened, allowing the robot to pick the wheels and place them in the storage area.

Finally, the cavities filling is simulated with the CAE software Moldex3D in order to evaluate the parts manufacturability. Starting from feasibility studies on already existing moulds, a tentative cost for the equipment and the parts is calculated. The final 3D models of the parts as well as the design of the related mould cavities is delivered. The IM machine to be used is identified.

3.3 Simulation-Based Design of the Mould

The third phase starts with the iteration of mould 3D modelling, CAE simulation (filling, packing, cooling, warpage), DfA, definition of the reconfigurable mould layout (see Fig. 2). This phase produces the BOM, as necessary to the tooling department. The design review and cost verification close the phase.

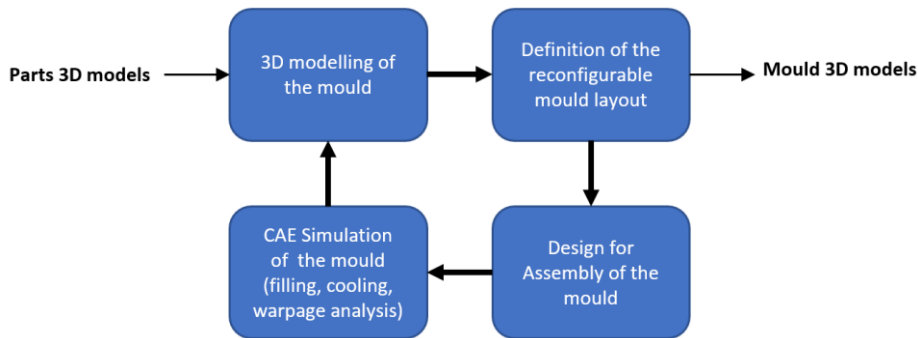

Fig. 2. Iterative cycle of design sub-phases, integrating DfA and CAE.

3D Modelling of the Mould. The 3D model of the mould is developed in Visi Mould, a vertical Computer-Aided Design software for mould design, which supports the reuse of standard components (e.g. mould plates), the automatic creation of drawings and BOM and the interference detection. In Visi Mould, the mould design is scheduled and managed in specific layers corresponding to the mould functional groups. Moreover, Visi Mould carries out the validation of the mould assembly with a dimensional check and possible improvement suggestions.

The modelling starts with a tentative two-cavities mould, with support plates compliant with the available injection machines (596mm x 796mm). The stationary and moving support plates are both 156mm height, as necessary to encompass the cavities for the largest wheel, the cooling channels and the holes for the clamping screws. The geometry of the stationary plate is shown in Fig. 3. The main components of the mould are the cavity inserts, to be mated together to compose the complete cavity for the molten plastic injection. The cavity inserts are modelled starting from the fixtures on the two support plates. In order to ensure the interchangeability of the cavity inserts, the same coupling between the various inserts and the support plates is used.

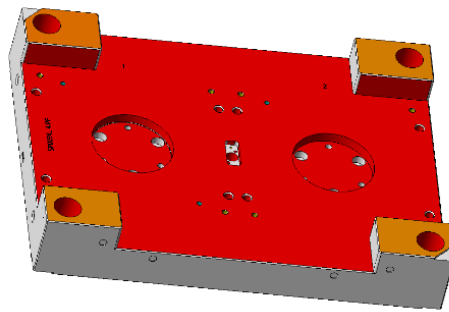

Fig. 3. Stationary plate of the reconfigurable mould.

The cavity inserts are sized 307mm x 90mm. Fig. 4 shows the two stationary cavity inserts for the A version wheel assembled in the stationary support plate. The diameter of the cavity is increased to 315mm in order to compensate for the volumetric shrinkage during solidification and to leave a machining allowance for the sequent turning operation. The hub is centered thanks to a conical seat (in grey in Fig. 4), together with an opposite cavity compressing it when the mould is closed in order to avoid any detachment. The rear cavity insert of the moving plate is designed (see Fig. 4b), with the ejectors, the seat of the centering ring for extraction and the additional air vents. The alignment between the two opposite inserts is ensured by a conical centering.

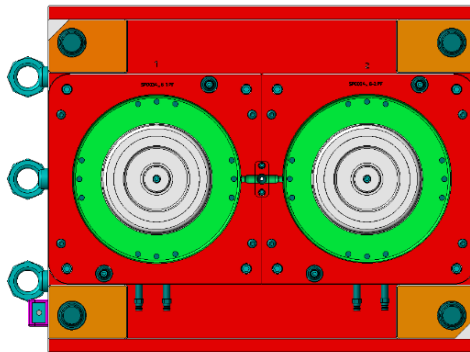

Fig. 4. The two cavity inserts for A version wheel assembled in the stationary plate.

Figure 5 shows a section of the whole mould. The mould cavities are light green coloured (n.1 in Fig. 5). A sprue (i.e. vertical channel, n.2 in Fig. 5) with an initial nominal diameter of 6mm is required from matching with the injection nozzle (5.5mm diameter). The runners (n.3 in Fig. 5) continue horizontally with a diameter sized considering the injection speed and the density of the melt material, and slightly larger than the following gate, in order to avoid pressure drops in the gate area. This would ease the material flow and its separation, while reducing the circular shrinkage. Furthermore, to enable the cavity inserts interchangeability, all the ejectors (dark green coloured, n.4 in Fig. 5) in the moving plate. Also the seats for the ejectors are machined into the inserts. Four cooling channels (light blue coloured, n.5 in Fig. 5) are axially symmetrical with respect to the wheel axis, and each sealed by two O-rings. The optimization of the cooling system, thanks to recursive IM simulations, leads to the reduction of the global shrinkage of the TPU coating. Accordingly, the shrinkage allowance in the cavities is reduced.

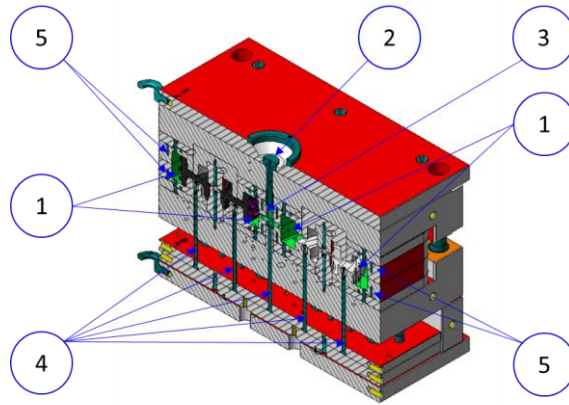

Fig. 5. Section view of the reconfigurable mould, for the A version wheel, with two cavities.

Design for Assembly and Mould Reconfigurability. The assembly of the cavity inserts is simplified with standard rectangular footprints to be mated into the support plates (see Fig. 6). The mating edges are properly chamfered. Then, the precise assembly of the plates is guaranteed by reference pins. The stability of the position of the pin seats is achieved by selecting the 1.2312 steel for the mould, heat treated in order to avoid its bending over time.

The reconfigurability is achieved with common mould plates, equipped with different cavity inserts when needed. To that purpose, other than the cavity, also the cooling channels and O-ring seats are modeled in the cavity inserts. The path of the cooling channels is adjusted in order to ease their drilling. Also the injection length and the ventilation ejectors have different configurations in the cavity inserts. On the other hand, standardized fittings are selected for the circuits in the cavity inserts. The final design of the cavity inserts assembled in the moving plate is shown in Fig. 6.



Fig. 6. Moving part of the reconfigurable mould.

CAE Simulation of the Mould. The CAE software Moldex3D is used for the simulations. The mould with the cavity inserts in the versions A and B are preliminarily simulated either with and without the cooling channels. The cooled versions lead to a 80% cycle time reduction. So, the cavity inserts are designed with the cooling system, since its additional costs are more than rewarded by the time reduction. In the end, the cavities are oversized by 1.5% in order to compensate for solidification shrinkage and leave machining allowance.

The part models are imported from Visi Mould using the .stp format and a solid mesh model is generated within Moldex3D. The TPU for the coating, the Nylon for the hub and the 1.2312 steel for the cavity inserts and plates are assigned to the models. The mesh of the cavities is optimized with a sensitivity analysis, as in [11]. In order to check the convergence and the correct shrinkage, the four bands of the coating are evaluated as for their flatness, as shown in Fig. 7a. One sensor node (i.e. a control point for analysis) was defined on each wheel in a position opposite to the gate, in order to analyse the deformation and the density. The flatness is stable as the mesh size varies. The shrinkage along the main directions is convergent in both the A and B versions. The density remains almost constant.

Fig. 7b shows the filling simulation for the cooled cavity inserts mould. The process parameters are reported in Table 1.

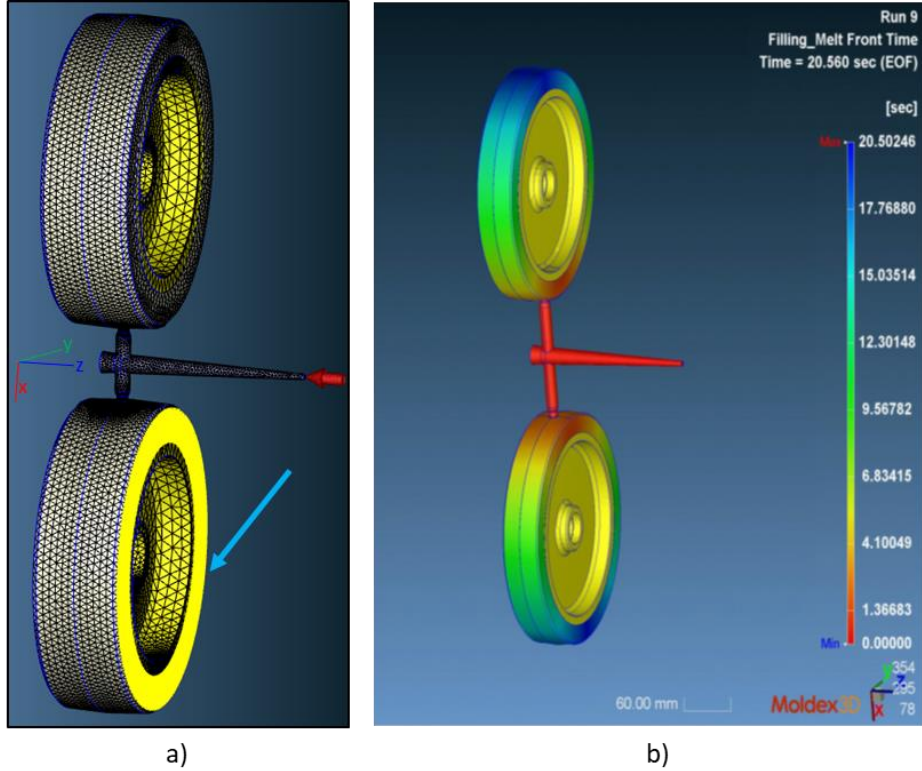

Fig. 7. a) The solid mesh model of the cavities: One of the four coating bands used for the flatness analysis is yellow coloured (pointed by the light blue arrow). b) Filling simulation of the two cavities in Moldex3D.

Table 1. Process parameters for the simulation of Version A (*Version B).

Parameter	Value	Parameter	Value
Max. Inj. pressure (MPa)	220	Max. Pack. pressure (MPa)	220
Filling time (s)	30 (*20)	Packing time (s)	15
Melt Temp. (°C)	190	Cooling time (s)	230
Mould Temp. (°C)	30	Mould-open time (s)	5
VP switch-over (% volume filled)	98	Eject time (s)	3

The four main process phases, namely, filling, packing, cooling and warpage, are optimized as in [13]. Fig. 8 reports the results of the uncooled version simulation to the left and the ones for the cooled version to the right.

The shrinkage along the radial direction is compensated by a greater wheel diameter, since the ovality defect will be corrected by a sequent turning operation. However, the parts produced with the reconfigurable cooled mold show a reduction in volumetric shrinkage (Fig. 8a) of both the maximum and average values.

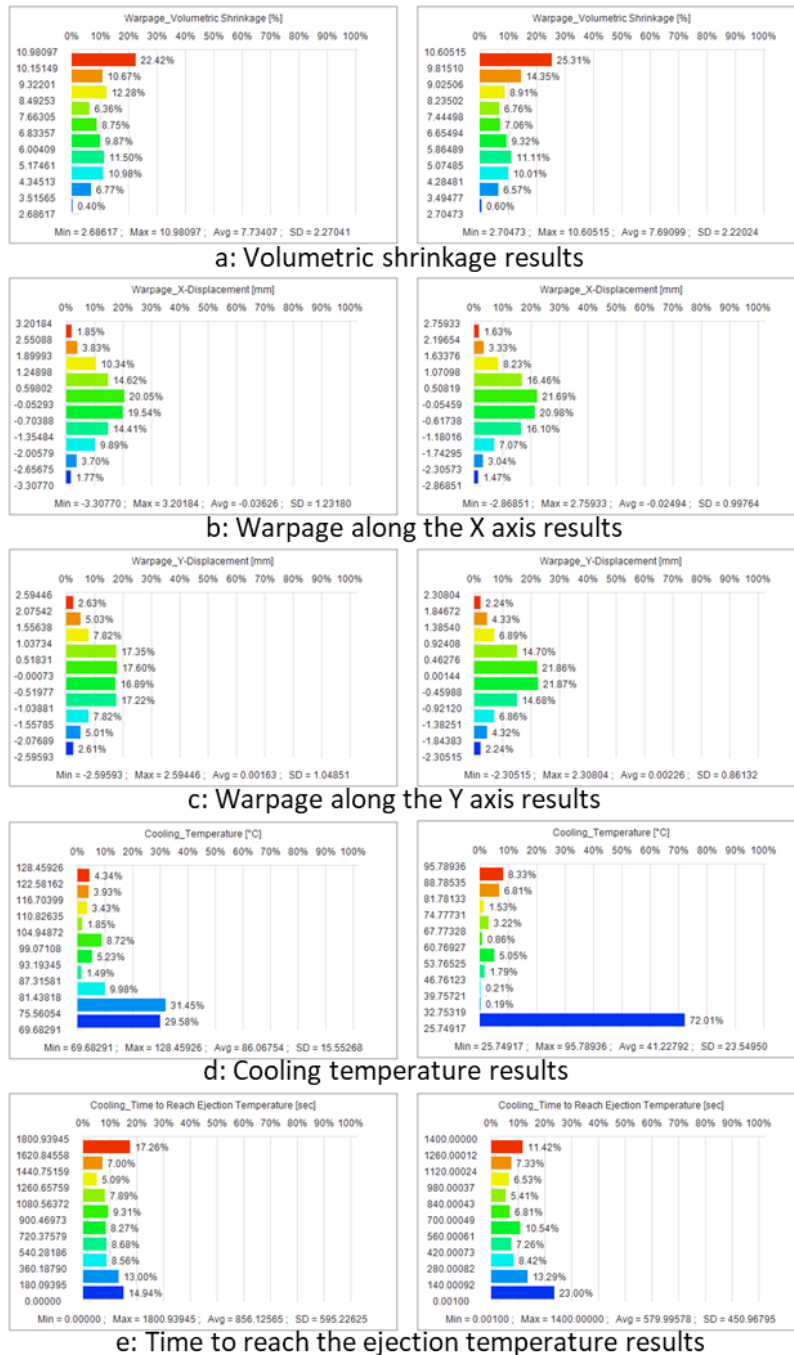

Fig. 8. Simulation results for the version A mould without (left) and with (right) the cooling system.

In particular, the shrinkage along the main directions (X and Y axis) in the histograms of Figs. 8b and 8c shows that a larger area of the wheel presents a warpage (displacement) around 0. The green bars are larger and higher (i.e. more points of the wheel show limited displacement with respect to the nominal position). The warpage along the flow direction, the X axis shown in Figs. 8b, results in maximum values for the gate position and for the opposite one. This produces in a total warpage of about 6.5mm in the simulation without the cooling system and about 5.5mm if it is used. A similar trend, even if with lower values, results for the Y axis of the wheel, as shown in Figs. 8c. The istograms in Figs. 8d show the final wheel temperature at the end of the cooling time. The final mean temperatures are much lower in the simulation with the cooling system, even considering the shorter cycle time. This guarantees a higher dimensional stability of the part. 72% of the coating of the cooled version is at 25 °C (see the blue bar), while in the version without cooling the minimum temperature is 70 °C. These results are finally confirmed by Figs. 8e, which show the time required to reach the ejection temperature.

Another effect of the cooling system is to reduce the hub ovalization in the overmoulding of different materials. In fact, the base material contacting the coating undergoes deformation. This is very often negligible, but may cause break in the service life of the wheel.

Finally, the total cycle time is evaluated as 368s for the uncooled simulation model and 283s for the cooled one. The cooling system reduces the cycle time by about 23%. The simulation results of the version B mould are omitted for sake of conciseness. Anyway, they are considered for adjusting the parameters of both A and B simulations. So, in the end, they confirm the version A results.

3.4 Part and Mould Detail Design

The fourth phase consists in the industrialization of the parts and reconfigurable mould. After dimensional checks and product testing, the detail design of the mould is released and then the mould is constructed, tested and tuned.

3.5 Mould Optimization

The fifth and last phase consists in the mould tuning and optimization through testing on physical and virtual prototypes. The simulation results are validated with the sampling data. Tables 2 and 3 show that the reconfigurable water cooled mould improves the parts quality, thanks to the reduction of the volumetric shrinkage. The mould efficiency increased as well, thanks to the reduction of the cycle time. The actual mould is shown in Fig. 9. The production of a pre-series of the parts concludes the method implementation.

Table 2. Comparison between the previous non-cooled and the cooled moulds for the version A

Version	Factors	Previous non-cooled mould	Reconfigurable cooled mould
A	Cavity diameter (mm)	317	315

Part diameter (post ejection) (mm)	311	310.5
Volumetric shrinkage (%)	1.80	1.43
Cycle time (s)	360	300
Wheels per hour	10	24
	(1 wheel per mould)	(2 wheels per mould)

Table 3. Comparison between the previous non-cooled and the cooled moulds for the version B

Version	Factors	Previous non-cooled mould	Reconfigurable cooled mould
B	Cavity diameter (mm)	255.5	254
	Part diameter (post ejection) (mm)	252	251
	Volumetric shrinkage (%)	1.36	1.16
	Cycle time (s)	173	143
	Wheels per hour	40	50
		(2 wheels per mould)	(2 wheels per mould)

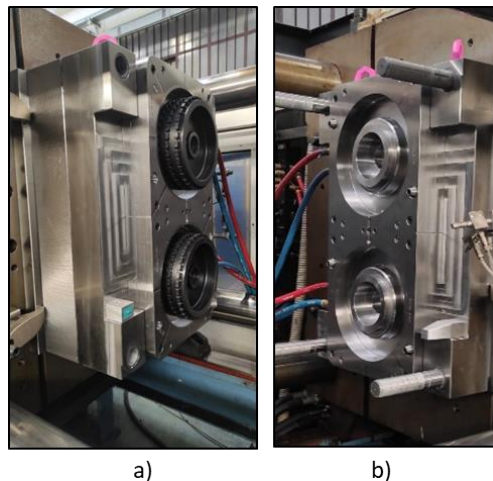

Fig. 9. The a) moving and b) stationary plates of the reconfigurable mould with the cavity inserts assembled.

4. Discussion and Conclusions

This paper describes a design method for reconfigurable moulds for the injection overmoulding. A case study on the design of a mould for industrial wheels of two different sizes is reported. The integration of DfA and CAE techniques from the early design phases enables to conceive a reconfigurable mould and to optimize its features, such as the cooling channels, the geometries of the runners and the cavity. Thanks to a more efficient cooling system, the current design requires a smaller oversizing of the

cavities to compensate for the material shrinkage. This leads to a 2.5 % volume reduction of the two cavities for the version A wheel (2.3% for the version B), requiring the injection machine to load and melt less material. Furthermore, an increase of the expected productivity is achieved, thanks to the reduction of the cycle time.

As future works, other versions and sizes of industrial wheels are being designed with the same integrated method and will be validated through the same procedures. The dies will be also improved with refined temperature control systems.

References

1. Wang, H., Zhou, X.H., Ruan, X.-Y.: Research on Injection Mould Intelligent Cost Estimation System and Key Technologies. *Int J Adv Manuf Technol*, 3, 215–222 (2003).
2. Peças, P., Henriques, E.: The need for agile manufacturing implementation in mould making business. In: *Proc. Business Excellence I*, Braga: Universidade do Minho, 321–326 (2003).
3. Galizia F.G., ElMaraghy W., ElMaraghy H., Bortolini M., Mora C.: The evolution of molds in manufacturing: from rigid to flexible. *Procedia Manufacturing* 33, 319–326 (2019)
4. Gaub, H.: Customization of mass-produced parts by combining injection molding and additive manufacturing with Industry 4.0 technologies. *Reinforced Plastics* 60(6), 401–404 (2016). DOI: 10.1016/j.repl.2015.09.004.
5. Singh, G., Verma, A.: A Brief Review on injection moulding manufacturing process. *Materials Today: Proceedings* 4(2), 1423–1433. (2017) DOI: 10.1016/j.matpr.2017.01.164
6. Miranda, D.A.D., Nogueira, A.L.: Simulation of an injection process using a CAE tool: Assessment of operational conditions and mold design on the process efficiency. *Materials Research* 22(2), (2019). DOI: 10.1590/1980-5373-mr-2018-0564M
7. Vergnano, A., Brambilla, E., Bonfiglioli, G.: Efficiency and reliability of casting process models for simulation based design. In: *International Joint Conference on Mechanics, Design Engineering & Advanced Manufacturing (JCM 2018)*, Lecture Notes in Mechanical Engineering, 3–12. Springer, Heidelberg (2019).
8. Boothroyd, G., Dewhurst, P.: *Product Design for Assembly*, 2nd edition, Boothroyd Dewhurst Inc., Wakefield, Rhode Island (1987).
9. Marson, S., Attia, U., Allen, D., Tipler, P., Jin, T., Hedge, J., Alcock, J.: Reconfigurable micro-mould for the manufacture of truly 3D polymer microfluidic devices. In: *Proceeding of the 19th CIRP Design Conference - Competitive Design*, pp 343–346 (2009).
10. Pugliese, V., Mesa, J., Maury, H.: Development of a design methodology for reconfigurable injection molds. *The International Journal of Advanced Manufacturing Technology* 90, 153–166 (2017).
11. Zah, M.F., Hagemann, F., Teufelhart, S.: Form-flexible tools for injection molding: approach for the economic application of injection molding for small lot sizes, *Production Engineering* 3, 281–285 (2009).
12. Pahl, G., Beitz, W., Feldhusen, J. Grote, K.H.: *Engineering Design: A Systematic Approach*; Springer: London, UK (2007).
13. Garlaschelli, G., Gherardini, F., Malagola, S., Leali, F.: Investigation of Warpage and Tolerances in Injection Moulding Components Based on Simulation and Experimental Validation. In: *2nd International Conference on Design Tools and Methods in Industrial Engineering, ADM 2021 Rome 9-10 September 2021, Code 269619*, Lecture Notes in Mechanical Engineering, 342–353. Springer, Heidelberg (2022).