

Accurate metering and billing of ambient loop systems

J. Kvist, Z. Ye *

School of the Built Environment and Architecture, London Southbank University, 103 Borough Road, London SE1 0AA, United Kingdom

ARTICLE INFO

Keywords:

Ambient loop
Heat pump
Metering
Billing

ABSTRACT

In order to reduce the operational energy consumption in the heating and cooling of buildings, the building industry is exploring methods of combining district heating and cooling networks where tenants' premises are equipped with individual water source heat pumps. This has the potential to create an ambient loop where tenants can exchange heat with each other, and a main source of heating or cooling can top up the energy demand of the loop. A challenge that arises in such a system is how the landlord can accurately bill tenants when energy is shared between tenants via the landlord's services loop. This study takes a theoretical approach on one potential solution where the billing model is developed to use data from energy meters and electricity meters, analyze the operational modes of the components in the system and proportion the energy usage accordingly.

1. Introduction

Global warming and climate change is a fact. The International Panel of Climate Change can say with 95% certainty that humans are the main cause of the current global warming [1]. Buildings are the single biggest contributor to energy consumption in the UK. Heating in buildings accounts for 25% of the UK's energy demand and 15% of its greenhouse gas emissions [2]. Over the last decade, researchers have studied various techniques for reducing energy consumption in buildings, such as the utilization of ambient energy [3], thermal energy storage [4–7], as well as district heating and cooling networks [8,9]. According to a study by Buffa et al. [8], district heating and cooling network technology is described as a promising solution to problems such as local emissions and primary energy consumption in the heating and cooling industry of buildings.

Marques et al. [9] investigated how an existing district heating network could be adapted with an ambient loop or 5th generation heat network. The study investigates the impact of connecting a 5th generation smart energy system with existing 3rd and 4th generation networks on the performance of a system. In their study, a Combined Heating and Power plant was replaced by a heat pump and a 3rd generation network connected into a 5th generation network. The results clearly showed that there are potential benefits for the performance of a heat network. Their study also discusses the potential economic savings and identifies the increased revenues as a potential tool to allow network owners to reduce the energy bills to their customers with the potential long-term effects being tackling fuel poverty.

Ambient loop systems tend to include a main air-to-water, air source heat pump (ASHP) as the primary source of energy that is supplied into a low-grade heat loop within the building from which tenant water-to-water, water source heat pumps (WSHPs) draw energy from the loop and then upgrade the thermal energy to a usable temperature for heating and/or domestic hot water and/or cooling [10]. Ambient loop systems have great potential to reduce operational carbon emissions by utilizing the low energy technology that heat pumps offer in combination with low water temperatures which increases the efficiency of the heat pumps and decreases the energy losses in the distribution system.

As a relatively new approach to heat generation and distribution in buildings, the deployment of ambient loop solutions comes with a few challenges. One of these challenges is related to the accurate metering and billing of energy consumption from the ambient loop where energy injected into the ambient loop by the landlord plant is coupled with continuous exchange of energy between tenants using the ambient loop. Therefore, it is a challenge to accurately apportion the consumption of energy injected into the ambient loop by the landlord plant to the correct end users of that energy.

Traditional metering and billing methods cannot be applied here due to the complications that arise from the continuous exchange of energy between tenants via the ambient loop. There does not exist a functional and fully operating metering and billing system that is able to account for the exchange of energy between tenants. This study aims to explore a theoretical solution to accurately bill tenants that are utilizing an ambient loop system for heating and cooling energy.

In this study, firstly the ambient loop system principle and associated metering challenges are discussed. Next, a numerical model which

* Corresponding author.

E-mail address: yez4@lsbu.ac.uk (Z. Ye).

<https://doi.org/10.1016/j.ijft.2022.100239>

Nomenclature			
ASHP	Air source heat pump	PHP_A	Tenant A's proportion of the main heat pump energy output
BUS	Boiler Upgrade Scheme	PHP_B	Tenant B's proportion of the main heat pump energy output
c_p	Specific heat capacity of water (kJ/kgK)	PHP_C	Tenant C's proportion of the main heat pump energy output
COP	Coefficient of Performance	PHP_i	Tenant i's proportion of the main heat pump energy output
$COP_{heating}$	Coefficient of Performance for the heat pump in heating mode	Q	Heat flow (W)
$COP_{cooling}$	Coefficient of Performance for the heat pump in cooling mode	$Q_{t,A}$	Energy consumption of tenant A at time t (kW)
CP	circulation pump	$Q_{t,B}$	Energy consumption of tenant B at time t (kW)
DHW	Domestic hot water	$Q_{t,C}$	Energy consumption of tenant C at time t (kW)
DPS	Differential pressure sensor	$Q_{t,i}$	Energy consumption of tenant i at time t (kW)
E_{ASHP}	Electricity consumption of the main air source heat pump (kW)	Q_{ASHP}	Main air source heat pump energy requirement (kW)
E_{CP}	Electricity consumption of the circulation pump (kW)	T_{A2}	Return water temperature from tenant A's branch (°C)
MID	Measuring Instruments Directive	T_{B2}	Return water temperature from tenant B's branch (°C)
Ofgem	Office of Gas and Electricity Markets	T_{C2}	Return water temperature from tenant C's branch (°C)
$P + I$ control	Proportional-integral control	T_c	Temperature of heat sink (K)
$PCPA$	Tenant A's proportion of the circulation pump energy consumption	T_H	Temperature of heat source (K)
$PCPB$	Tenant B's proportion of the circulation pump energy consumption	T_{i1}	Flow water temperature for tenant i's branch (°C)
$PCPC$	Tenant C's proportion of the circulation pump energy consumption	T_{i2}	Return water temperature from tenant i's branch (°C)
PCP_i	Tenant i's proportion of the circulation pump energy consumption	T_{m1}	Flow water temperature in the ambient loop (°C)
		T_{m2}	Return water temperature in the ambient loop (°C)
		\dot{v}	Volume flow rate (m ³ /s)
		W	Work inputted to heat pump (W)
		WSHP	Water source heat pump
		ρ	Density of water (kg/m ³)

enables appropriate distribution of energy consumption charges to end users of the ambient loop and accurate billing of tenants is developed. It has been found that an accurate metering and billing ambient loop system offers economic benefits for both landlord and tenants. Most importantly, the results of this study would also benefit future solutions both from an energy efficiency and carbon saving perspective.

2. Theoretical background of reversible heat pumps

A heat pump is a machine that absorbs heat from a cool space ('heat source') and releases it to a warmer space ('heat sink'). Depending on the mode of the heat pump, the heat source and sink can vary. A reversible heat pump is equipped with a reversing valve that redirects the flow of refrigerant and therefore switches the heat sink with the heat source and vice versa, depending on the current demand of the treated space.

A reversible heat pump is made up of five main components: indoor heat exchanger, outdoor heat exchanger, compressor, reversing valve and expansion valve. In a non-reversible heat pump, the indoor and outdoor heat exchangers are usually referred to as the evaporator and condenser units. However, in a reversible heat pump the function of the units will vary depending on the current operational mode (heating or cooling) which is why they are defined differently for the reversible heat pump. Figs. 1 and 2 demonstrate the simplified schematics of the two modes of the reversible heat pump.

Depending on the type of heat pump, the indoor and outdoor heat exchangers can absorb or release heat to different media. The outdoor heat exchanger can be connected to air, water or the ground. The indoor heat exchanger can be connected to air or water, depending on which type of system is used for heating and cooling in the building(s). In this study, water-to-water WSHPs were used in each tenant's loop, meaning both the indoor and outdoor units exchange heat with water. For clarification, the outdoor unit is not necessarily installed outside of the building but is a way of differentiating the name of the unit that is not actively treating the space.

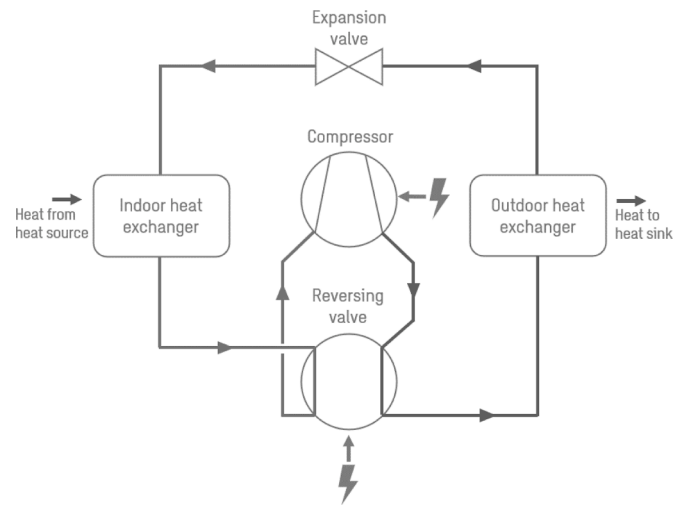

Fig. 1. Reversible heat pump in cooling mode.

Heat pumps consume electricity as a fuel. As demonstrated in Figs. 1 and 2, there is an electric input to the compressor and the reversing valve. In comparison to the electrical input to the compressor, the electrical input to the reversing valve is significantly smaller and will be considered to be negligible later in this study when analysing energy usage by the heat pump. The efficiency of the heat pump is measured and evaluated using a Coefficient of Performance (COP). The actual COP is calculated as the ratio of useful heat or removed heat (Q , (W)) to the work required, i.e. the electrical input (W , (W)). The COP typically varies between 2 and 5 [11].

$$COP = \frac{Q}{W} \tag{1}$$

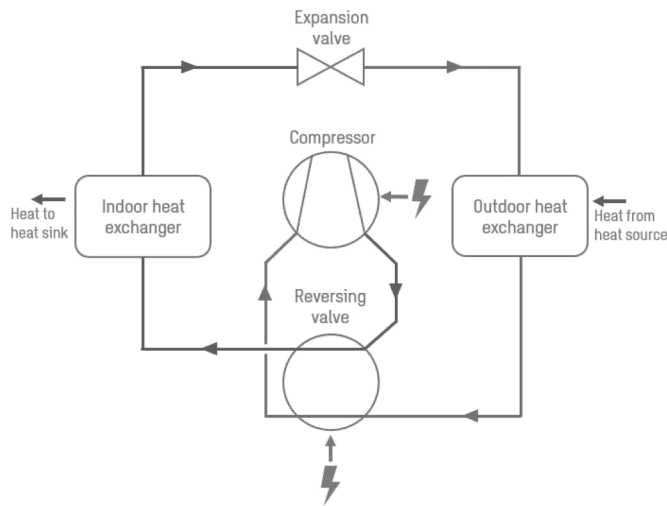

Fig. 2. Reversible heat pump in heating mode.

The heat pump’s theoretical COP can be calculated directly using the temperatures of the heat source and heat sink [11]. The theoretical COP for the heating ($COP_{heating}$) and cooling ($COP_{cooling}$) modes of a heat pump are given below:

$$COP_{heating} = \frac{T_H}{T_H - T_C} \quad (2)$$

$$COP_{cooling} = \frac{T_C}{T_H - T_C} \quad (3)$$

where T_H is the temperature of the heat source (K) and T_C is the temperature of the heat sink (K).

Reversible heat pumps can also generate domestic hot water (DHW). DHW generation generally requires a higher temperature than water that is used for space heating. Also, as proven by the Carnot efficiency principle, the lower the temperature of the heat sink, the better the performance of the heat pump. The second issue with DHW generation by reversible heat pumps is the scenario that occurs when a space that is treated requires cooling from the heat pump and DHW needs to be generated at the same time. The heat pump is not able to produce cooling to the space and heating for the DHW in the same operation but needs to prioritize one of the two operations. As of now there is no solution for this problem that does not include the introduction of another source of heating for the DHW while the heat pump generates cooling for the space.

3. The ambient loop system principle and associated metering challenges

The principle of the ambient loop system is that users exchange energy with each other, rather than a central plant producing heating and cooling to serve end users. For tenants to use the ambient loop they will have a water-to-water WSHP connected to the loop which will act as the ‘outdoor heat exchanger’, as shown in Fig. 3. The temperature of the ambient loop is maintained at around 30 °C by a main reversible air-to-water ASHP, which can either inject or reject heat energy to or from the loop as necessary to maintain the required temperature of the loop. The reversible WSHP within each tenant’s premises, connected to this ambient loop, either delivers higher temperature water to the tenant’s premises for space heating or DHW by drawing energy from the loop, or extracts heat from the tenant’s premise to provide cooling and then rejects this energy back into the ambient loop. Due to the lower temperature of the circulating water, the same loop can be used for both heating and cooling by the heat pumps installed within each tenancy.

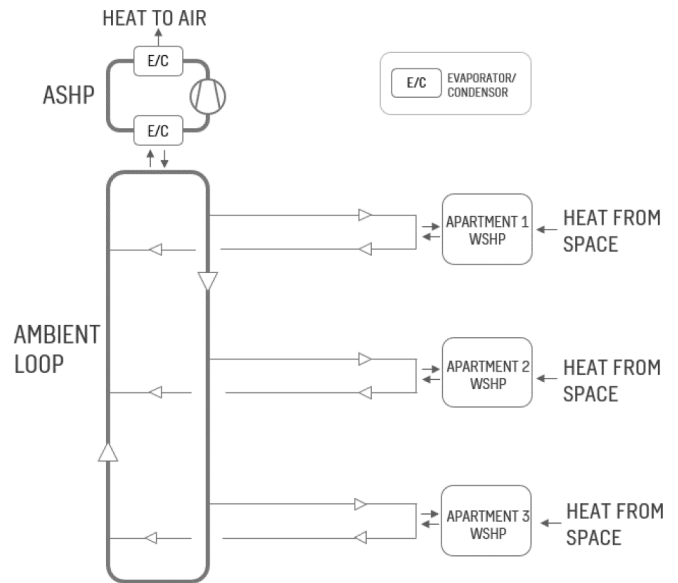

Fig. 3. Ambient loop system principle.

3.1. Ambient loop operation during peak winter periods

The simplest scenario for the operation of the ambient loop is during peak winter periods, where tenants are either demanding energy for space heating, or DHW, or both, as shown in Fig. 4. In this scenario, the energy flow is only inward. The electricity meter serving the heat pump can record the electrical energy used by the heat pump compressor, or a heat meter on the entry to the tenant’s premises can measure the temperature drop in the ambient loop caused by the tenant’s demand. Additionally, an electricity meter and heat meter at the landlord’s main ASHP could measure the energy used to heat the ambient loop.

3.2. Ambient loop operation during periods other than peak winter periods

The scenarios where operation of the ambient loop becomes complicated from a tenant metering perspective are when tenants use the loop during periods of simultaneous heating and cooling demands, as shown in Fig. 5.

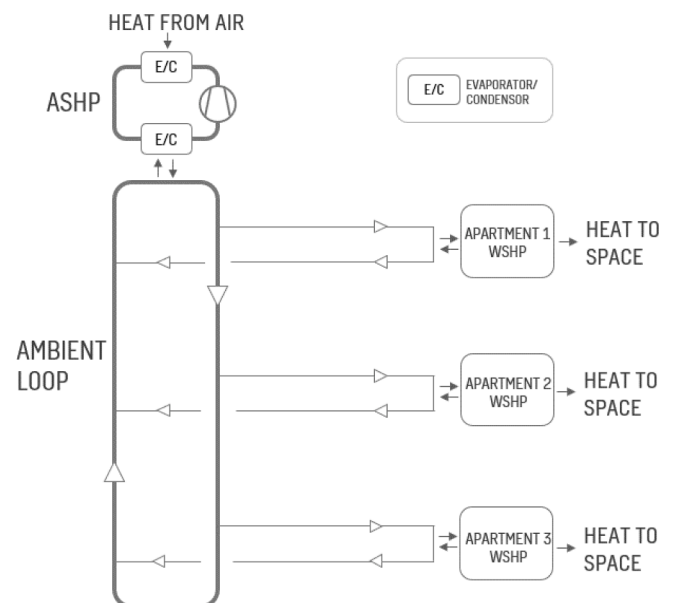

Fig. 4. Typical ambient loop operation during winter period/peak time.

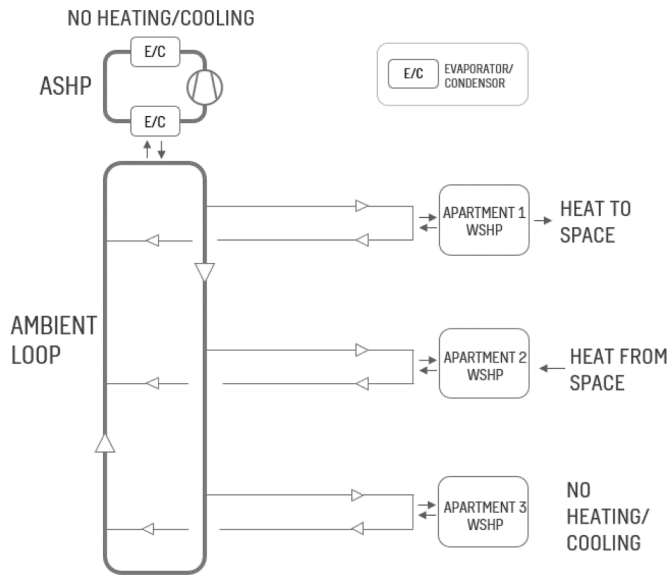

Fig. 5. Typical ambient loop operation during energy exchange between apartments.

Demand for heating or DHW within the tenant’s premises will always require an energy flow in from the ambient loop, however a cooling demand will create an energy flow out to the ambient loop. Therefore, if one apartment is demanding energy for heating or DHW and an adjacent apartment is rejecting heat to provide cooling, then the temperature of the ambient loop may not alter at all, and the heat and electricity meters serving the landlord’s main ASHP would record no change despite both tenants using the ambient loop. However, the electricity and heat meters serving the heat pumps within the tenant premises would record usage.

3.3. Challenges of the ambient loop system

The operating principles of the ambient loop system raises a challenge during periods of simultaneous heating and cooling demands when individual tenants’ WSHPs are exchanging energy within the loop at the same time as the landlord main ASHP is injecting or rejecting energy to or from the loop. It is a challenge to accurately determine the proportion of the individual tenant’s energy consumption from the main ASHP output in order to bill the tenant.

4. Billing strategy

All utilities crossing a building’s boundary line need to be paid for. There can be many different ways to prepare a bill. This depends on how the system itself is working, how accurate the billing is and how a building’s utilities are set up. The typical hierarchy is for an energy provider to bill a landlord and for the landlord to bill the tenants. For some utilities a tenant can be in direct contact with the utility company. This is often more common when the tenant is a retail tenant in a commercial or residential building.

In a fully residential building that is owned and managed by the landlord, the most common solution is for the tenants to be billed directly by the landlord.

In a system consisting of an ambient loop, tenants’ WSHPs and a main ASHP, the billing trees can be shown as in Figs. 6 and 7. Fig. 6 illustrates the electricity billing tree, where the landlord is directly billed by the utility provider. The landlord will then bill the tenants, based on their consumption. It is necessary that bills are created by data from actual meter readings, and not simply calculated as a function of the size of the premises or similar attributes. This sort of concept is not accepted by the Heat Network (Meter and Billing) Regulations 2014 [12].

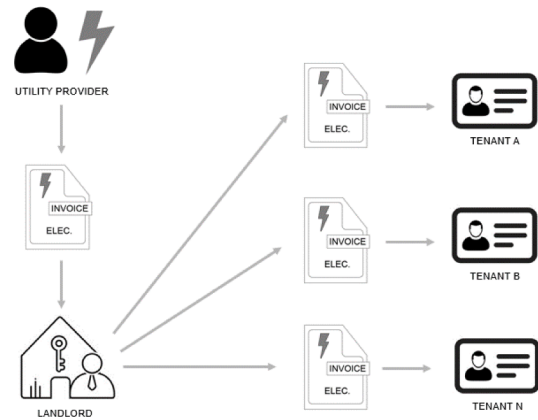

Fig. 6. Billing tree for electricity bills.

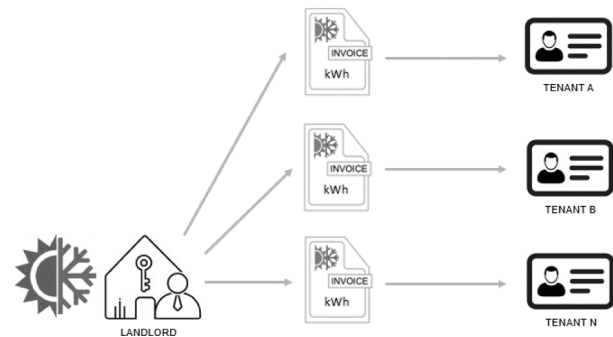

Fig. 7. Billing tree for heating and cooling bills.

Fig. 7 illustrates the billing tree for heating and cooling energy, where the heating and cooling system is made up of an ambient loop system with tenants’ WSHPs and a main ASHP that operates when the energy exchange between tenants in the loop is not sufficient. The heating and cooling energy is generated by the landlord’s plant, and the energy in the building is distributed by the landlord’s plant, hence the landlord directly bills the tenants for their energy consumption. Accurate billing is complicated, since tenants only pay for the heating and cooling generated by the landlord’s plant, and do not pay for the heating and cooling that they receive as a consequence of heat exchange with other tenants. The complexity in the billing model lies in determining where the heating and cooling that a tenant is consuming is generated from.

5. Methodology of accurate meeting and billing of end users

The methodology developed in this study is a theoretical and conceptual approach to ambient loop systems rather than an actual design for a specific project. The reason for this approach is to make the methodology more applicable to other types of projects. What is later going to be named as Tenant *i* can potentially be an apartment tenant, retail tenant, office tenant or other. In this study, the number of tenants has been scaled down to three representative tenants. This is to simplify and shorten the calculations and results, but the theoretical concept is still the same and the same principles in the methodology based on the three tenants can be applied to any configuration of multiple tenants with mixed types of use (apartments, retail, office, etc.).

5.1. The ambient loop system

An ambient loop is where the primary source of heating and cooling is a reversible ASHP, and each tenant connects to the loop with a

dedicated reversible WSHP. The temperature of the ambient loop is constantly set to be 30 °C. This is controlled by temperature sensors measuring the flow and return of the circulating water. If the measured return temperature is less or more than 30 °C, the main reversible ASHP will start working to achieve the constant flow temperature.

Within the ambient loop, there are multiple points of energy consumption that continuously change. This requires carefully-placed meters in the system that communicate with the Building Management System to send signals to control the operation of the ambient loop systems.

Fig. 8 illustrates a schematic flowchart of the energy exchange system. Energy meters and electricity meters are indicated. The data collected from these meters will make up a part of the data used in the billing model. The main ASHP and circulation pump are metered for electricity usage and the ambient loop branch and tenant branches are metered for heat energy.

5.2. Ambient loop system control strategies

Properly developed control strategies are essential to ensure the ambient loop delivers correct heating and cooling to meet tenants' requirements.

5.2.1. Tenant branches

In case a tenant's branch is completely shut off, i.e. (1) there is no demand as no tenant is occupying the space or (2) the tenant WSHP has failed, the ambient loop system dynamics will be affected. When the tenant WSHP is completely disabled, this sends a signal to a control valve on the primary side of the WSHP to fully close the valve, allowing no water to flow through and therefore the heating or cooling energy requirements from the ambient loop will increase or decrease depending on the operational mode of the individual tenant WHSP, i.e. the energy requirement from the ambient loop will increase if the failed tenant WHSP is in the opposite operational mode to the other tenant WHSPs, otherwise the energy requirement from the ambient loop will decrease if they are in the same operational mode. This will cause a pressure increase in the system. Similarly, when there is a demand within the

apartment, the WSHP will fully open the valve on the primary side of the WSHP which will lead to a decrease of the pressure in the system. This arrangement is detailed within Fig. 9.

5.2.2. Ambient loop circulation pump

As the ambient loop aims to operate with a constant temperature and a variable volume flow rate, the increased pressure in the system requires the circulation pump to turn down in order to meet a system pressure set point. To achieve this, the circulation pump needs to be a variable speed pump. In order for the pump to know what speed to run at, the system has to be equipped with a differential pressure sensor (DPS) strategically positioned across the flow and return pipework of the ambient loop, as shown in Fig. 9.

The DPS measures the pressure differential from its set-point and will be used as the pressure control variable. When the system is operational, the DPS will sequence and modulate the speed of the duty pumps via the proportional-integral control ($P + I$ control) loop to maintain the required pressure differential set-point.

The circulation pump requires a minimum flow in order to operate safely and not cavitate. If the required flow rate in the ambient loop is lower than the minimum flow rate required at the circulation pump set, as specified by the pump manufacturer, then a bypass is required to maintain the minimum flow requirement at the circulation pump set. This minimum flow protection is provided using a minimum flow bypass control valve and a flow meter, as shown in Fig. 9.

When the system is operational, a flow meter, located in the common flow pipe work, will via a $P + I$ control loop, modulate the 2-port minimum flow control valve located adjacent to the pump set to maintain the dynamic minimum flow set-point required by the pump set.

The maximum flow rate setting of the minimum flow control valve will be set so that the flow rate setting is marginally above the required minimum flow of the pump set.

5.2.3. Main air source heat pump

The main ASHP provides heating or cooling energy to the ambient loop when the energy exchange of the tenants is unbalanced. The main ASHP operation is controlled by a temperature sensor mounted in the ambient loop. The sensors in water systems will be of the immersion type and will be mounted in pockets inserted into the pipework.

The full active length of the sensor will be immersed in the medium. The sensor will be installed against the direction of flow and at the correct angle. Where the sensor detects a mixed medium condition, a minimum distance of ten times the pipe diameter will be maintained between the mixing point and the sensor to take account of stratification. The temperature sensor will be positioned as shown in Fig. 9.

5.3. Operational modes

The ambient loop operational modes are set up in order to analyze how the main ASHP and the tenants' WSHPs operate, and the impact in terms of energy usage and cost for the tenants' various operational modes.

The operational modes represent each 5 min reading for one hour. Table 1 does not give realistic meter readings of the ambient loop system but gives examples of unique operational modes that can occur.

5.4. Principles of the billing model

The analysis begins with the data retrieved from the tenants' metering stations. The meter sitting on the tenant's branch feeds information on the return temperature from the tenant to the loop as well as the volume flow rate. This data is then used in Eq. (4) below for billing purposes to calculate the instantaneous effect of energy usage ($|Q_{t,i}|$ (kW), energy used by tenant i , out of N total tenants, at time t) that a tenant is using at a certain moment in time.

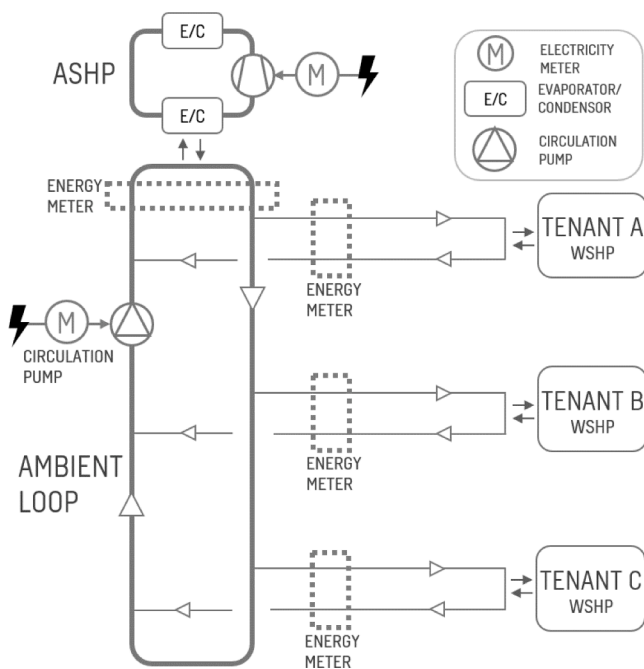

Fig. 8. System schematic for an ambient loop system with a main Air Source Heat Pump (ASHP) and individual Water Source Heat Pumps for tenants (WSHP).

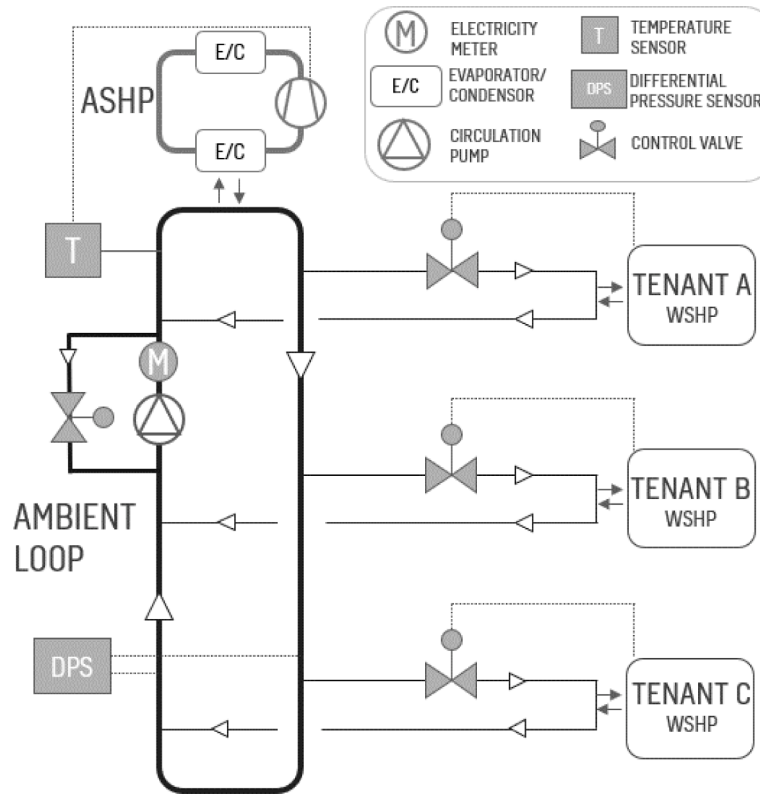

Fig. 9. Control mechanisms for the ambient loop systems.

Table 1
Summary of operational modes for the tenants and main heat pumps.

No. of Readings	Tenant A Heat pump	Tenant B Heat pump	Tenant C Heat pump	Main Heat pump
1	Off	Off	Off	Off
2	Heating	Off	Off	Heating
3	Heating	Heating	Heating	Heating
4	Heating	Cooling	Cooling	Cooling
5	Heating	Cooling	Cooling	Heating
6	Cooling	Cooling	Cooling	Cooling
7	Cooling	Heating	Heating	Off
8	Cooling	Heating	Off	Off
9	Cooling	Heating	Off	Off
10	Cooling	Heating	Heating	Heating
11	Heating	Heating	Cooling	Off
12	Off	Cooling	Heating	Off

$$|Q_{t,i}| = \dot{v} \times \rho \times c_p \times (T_{i1} - T_{i2}) \quad (4)$$

where \dot{v} (m³/s) represents the volume flow rate at the measured data instance. For the tenant branches, the volume flow rate will be constant, and the ambient loop flow rate will vary depending on how many tenants are active. The density ρ (kg/m³) is data that is already programmed as a function of temperature within the billing model. c_p (kJ/kgK) is the specific heat capacity for water and varies depending on the temperature of the water at the time it was measured. T_{i1} (°C) is the temperature of the flow for tenant i and is set to be a constant 30 °C for this study. T_{i2} (°C) is the return temperature from the tenant to the ambient loop. In this methodology, the value of T_{i2} takes a more theoretical approach than what would be used in practise and an arbitrary temperature is used in calculations.

Depending on the current mode of the heat pump, $Q_{t,i}$ can be either negative (cooling mode) or positive (heating mode), hence the function in Eq. (4) is set up to only calculate the absolute value of $Q_{t,i}$. For the next step in the analysis, the operational modes of all heat pumps for the

current interval should be identified when the energy usage of the main ASHP is proportioned by the tenants' WSHPs that use it.

A similar exercise for calculating the energy needs in each tenant's branch will be undertaken for the main ASHP. In an operating system, the return temperature of the loop will be measured, and the energy need of the main ASHP will be calculated by using proportionating balance theory. As this methodology is taking a theoretical approach and no temperature or flow rate has been measured, the following analysis will be made with regards to the main ASHP energy requirements (Q_{ASHP} , (kW)).

$$Q_{ASHP} = \sum_{i=A}^N Q_{t,i} \quad (5)$$

Eq. (5) calculates the energy requirement Q_{ASHP} that the main ASHP is required to provide to the loop after the tenant's energy exchange has been completed. If the value of Q_{ASHP} is a positive value, this means that the ambient loop requires heating energy from the main ASHP, as heating energy has been taken from the loop by the tenants (after the heat exchange between tenants has been conducted). If Q_{ASHP} is a negative value, this means that the ambient loop temperature has increased in temperature and requires cooling from the main ASHP as the tenants are cooling their spaces and discharging heat into the ambient loop.

$$T_{m2} = T_{m1} - \frac{Q_{ASHP}}{\dot{v} \times \rho \times c_p} \quad (6)$$

Eq. (6) calculates the return temperature of the ambient loop (T_{m2} , (°C)). T_{m1} (°C) is the flow temperature of the ambient loop. In an actual operating system, T_{m1} will be a measured value, while Eq. (6) and calculated results are taken into the scope to demonstrate completeness of the energy analysis.

Once the energy requirements $Q_{t,i}$ and Q_{ASHP} have been calculated for all tenants' WSHPs and the main ASHP, and the analysis of which tenants are in cooling and heating mode has been undertaken, the

following step is to identify for each of the tenant's WSHPs whether they are operating in the same mode as the main ASHP or not. All tenant WSHPs that operate in the same mode as the main ASHP will be part of the proportioning of energy for the time interval. If the tenant WSHP is not in the same mode as the main ASHP, this means that this tenant currently takes advantage of the loop and will not be part of the proportioning.

Using Eq. (7), tenant i 's proportion of the main heat pump (PHP_i) energy output is calculated as the ratio between the current tenant's total energy consumption for the current interval over the total energy consumption by tenants in the same operational mode. This is under the condition that the main ASHP operates in the same mode. If not, the tenant proportion is zero.

$$PHP_i = \frac{|Q_{t,i}|}{\sum_{i=A}^N |Q_{t,i}|} \quad (7)$$

Similar logic is applied to the proportioning of heating and cooling energy, the electrical energy consumed by the circulation pump of the ambient loop will also be proportioned over the tenants using it. The difference with the calculation of the circulation pump apportioning (PCP_i) is that it includes all tenants regardless of whether the tenant's WSHP is in the same operational mode as the main ASHP or not. This is because regardless of whether the tenant is exchanging heating or cooling with the loop, the tenant uses the loop to circulate water and therefore this is justifiably part of the bill.

$$PCP_i = \frac{|Q_{t,i}|}{\sum_{i=A}^N |Q_{t,i}|} \quad (8)$$

The tenant's calculated proportions are then multiplied with the measured energy consumption for the main ASHP and the circulation pump. The result of this is multiplied with the time interval and cost of electricity at the moment of the meter reading. All this data is then added together for an accurate monthly bill for each tenant.

5.5. Parameters for billing modelling

In Table 2, all data that has been used for this study is provided, as well as clarifications on whether the data is only an assumed constant in the theoretical approach or the data will be measured in the real application.

6. Results and discussion

The result of this study is to present a methodology for an accurate metering and billing system for an ambient loop system where tenants connect to the ambient loop with dedicated WSHPs. The system allows tenants to exchange energy with each other via the ambient loop, and if required a main ASHP provides additional heating or cooling to the loop.

6.1. Tenant energy consumptions

Example meter readings from the meters on the tenant branches of the circulation water temperatures are shown in Table 3. Energy consumption is calculated for the instantaneous meter reading. The billing model is used to identify whether or not the tenant's WSHP is in heating, cooling or off based on the energy calculation. If the energy calculation results in a positive value, this means that the return temperature is lower than the flow and that the tenant WSHP is in heating mode. If the energy is a negative value, this means that the tenant WSHP is in cooling mode. If the energy is zero, the tenant WSHP is not operating at all.

6.2. Main heat pump and circulation pump energy consumption and costs

The analysed and calculated values of energy and costs for the landlord's circulation pump and main ASHP are shown in Table 4. The

Table 2
Data inputs for the billing model and how to use in real application.

	Unit	Value	Notes
Time interval	h	0.083	Time interval represents 5 min data readings. Can vary depending on project and requirements.
Tenant volume flow rate, \dot{v}	m ³ /s	0.001	Will be measured. Assumed value for purpose of demonstration.
Water density, ρ	kg/m ³	997	Constant, however actual billing models will use specific heat capacity data for respective temperatures.
Specific heat capacity, c_p	kJ/kgK	4.2	Constant, however actual billing models will use specific heat capacity data for respective temperatures.
$COP_{heating}$	N/A	4	Will be measured. COP varies during operation.
$COP_{cooling}$	N/A	3	Will be measured. COP varies during operation.
Electricity price/kWh	£	0.1	Price assumed for demonstration purposes. In actual application, the current price of electricity will be used for billing generation.
Ambient loop volume flow rate, \dot{v}	m ³ /s	0.003	Will be measured. Assumed value for demonstration purposes.
Tenant flow temperature, T_{i1}	°C	30	Assumed value for demonstration purposes. In actual application, the temperature will be measured. Target temperature can vary depending on project and requirements.
Tenant return temperature, T_{i2}	°C	20–37	Assumed value for demonstration purposes. In actual application, the temperature will be measured.
Ambient loop flow temperature, T_{m1}	°C	30	Assumed value for demonstration purposes. In actual application, the temperature will be measured. Target temperature can vary depending on project and requirements.

table summarises the total energy consumption by the tenants, both heating and cooling, and the result informs the main ASHP of what operational mode it needs to work in. In operational modes where the tenant's energy exchange is not sufficient, the main ASHP operates in order to top up any heating or cooling energy that has been withdrawn. Table 4 also identifies if the main ASHP is not operating, i.e., in balanced mode and if the balanced mode is a consequence of no need to input heating or cooling to the loop because the tenant's energy exchange is balanced or because the tenants are all not operating, like the operational mode for meter reading No. 1. This analysis is important because it also informs the circulation pump whether it needs to operate or not.

6.3. Billing of each tenant

The electricity consumption of the main ASHP and circulation pump as well as the associated costs at each time interval for each tenant are calculated based on the load proportions of heating, cooling and the circulation pump. As Tables 5-7 demonstrate, the billing model is used to analyze the modes of the tenant heat pumps, the mode of the main ASHP and the circulation heat pump. The result is analysed to show the exact amount of the energy consumption of the main ASHP caused by each tenant and how much of the circulation pump energy consumption has been caused by each tenant.

Table 8 shows the resulting bill for each tenant and the landlord for one hour of operation. The sum of the bills for Tenants A, B and C is the same value as the bill that the landlord received from the utility company.

6.4. Evaluation of the billing model

The expectations of the metering and billing model were that it should be able to accurately meter and gather the data that is required

Table 3
Tenant energy consumptions.

No. of Readings	Tenant A Operation mode	T _{A2} (°C)	Q _{t,A} (kW)	Tenant B Operation mode	T _{B2} (°C)	Q _{t,B} (kW)	Tenant C Operation mode	T _{C2} (°C)	Q _{t,C} (kW)
1	Balanced	30	0.00	Balanced	30	0.00	Balanced	30	0.00
2	Heating	25	20.94	Balanced	30	0.00	Balanced	30	0.00
3	Heating	25	20.94	Heating	25	20.94	Heating	25	20.94
4	Heating	25	20.94	Cooling	35	-20.94	Cooling	35	-20.94
5	Heating	20	41.87	Cooling	32	-8.37	Cooling	32	-8.37
6	Cooling	35	-20.94	Cooling	35	-20.94	Cooling	35	-20.94
7	Cooling	36	-25.12	Heating	27	12.56	Heating	27	12.56
8	Cooling	35	-20.94	Heating	25	20.94	Balanced	30	0.00
9	Cooling	35	-20.94	Heating	25	20.94	Balanced	30	0.00
10	Cooling	33	-12.56	Heating	28	8.37	Heating	27	12.56
11	Heating	24	25.12	Heating	29	4.19	Cooling	37	-29.31
12	Balanced	30	0.00	Cooling	32	-8.37	Heating	28	8.37

- Note: 1. T_{A2}, T_{B2} and T_{C2} are the return water temperatures from Tenants A, B and C's heat pumps.
2. Q_{t,A}, Q_{t,B} and Q_{t,C} are the energy consumption of Tenants A, B and C.
3. All the supply water temperatures to Tenants A, B and C's heat pumps are 30 °C.

Table 4
Main heat pump and circulation pump energy consumption and costs.

No. of Readings	Operation mode	T _{m2} (°C)	Q _{ASHP} (kW)	E _{ASHP} (kW)	E _{CP} (kW)	ASHP Cost (£)	CP Cost (£)
1	Balanced	30.0	0.00	0.00	0	0.000	0.000
2	Heating	28.3	20.94	5.23	3	0.044	0.025
3	Heating	25.0	62.81	15.70	3	0.131	0.025
4	Cooling	31.7	-20.94	6.98	3	0.058	0.025
5	Heating	28.0	25.12	6.28	3	0.052	0.025
6	Cooling	35.0	-62.81	20.94	3	0.174	0.025
7	Balanced	30.0	0.00	0.00	3	0.000	0.025
8	Balanced	30.0	0.00	0.00	3	0.000	0.025
9	Balanced	30.0	0.00	0.00	3	0.000	0.025
10	Heating	29.3	8.37	2.09	3	0.017	0.025
11	Balanced	30.0	0.00	0.00	3	0.000	0.025
12	Balanced	30.0	0.00	0.00	3	0.000	0.025

- Note: 1. T_{m2} is the return water temperature of the ambient loop.
2. Q_{ASHP} is the energy required by the main air source heat pump.
3. E_{ASHP} is the electricity consumption of the main air source heat pump.
4. E_{CP} is the electricity consumption of the circulation pump.
5. ASHP is the main air source heat pump.
6. CP is the circulation pump.

Table 5
Tenant A proportioning and cost for main heat pump and circulation pump.

No. of Readings	PHP _A	PCP _A	E _{ASHP} (kW)	E _{CP} (kW)	ASHP Cost (£)	CP Cost (£)
1	0.00	0.00	0.00	0.00	0.00	0.00
2	1.00	1.00	5.23	3.00	0.04	0.03
3	0.33	0.33	5.23	1.00	0.04	0.01
4	0.00	0.33	0.00	1.00	0.00	0.01
5	1.00	0.71	6.28	2.14	0.05	0.02
6	0.33	0.33	6.98	1.00	0.06	0.01
7	0.00	0.50	0.00	1.50	0.00	0.01
8	0.00	0.50	0.00	1.50	0.00	0.01
9	0.00	0.50	0.00	1.50	0.00	0.01
10	0.00	0.38	0.00	1.13	0.00	0.01
11	0.00	0.43	0.00	1.29	0.00	0.01
12	0.00	0.00	0.00	0.00	0.00	0.00

- Note: 1. PHP_A is the tenant A's proportion of the main air source heat pump energy output.
2. PCP_A is the tenant A's proportion of the circulation pump load.
3. E_{ASHP} is the electricity consumption of the main air source heat pump.
4. E_{CP} is the electricity consumption of the circulation pump.
5. ASHP is the main air source heat pump.
6. CP is the circulation pump.

for the methodology as detailed in Section 5.

In the model of this study, the return temperature of the ambient loop (T_{m2}) is calculated by using Eq. (6). In a real system, this

Table 6
Tenant B proportioning and cost for main heat pump and circulation pump.

No. of Readings	PHP _B	PCP _B	E _{ASHP} (kW)	E _{CP} (kW)	ASHP Cost (£)	CP Cost (£)
1	0.00	0.00	0.00	0.00	0.00	0.00
2	0.00	0.00	0.00	0.00	0.00	0.00
3	0.33	0.33	5.23	1.00	0.04	0.01
4	0.50	0.33	3.49	1.00	0.03	0.01
5	0.00	0.14	0.00	0.43	0.00	0.00
6	0.33	0.33	6.98	1.00	0.06	0.01
7	0.00	0.25	0.00	0.75	0.00	0.01
8	0.00	0.50	0.00	1.50	0.00	0.01
9	0.00	0.50	0.00	1.50	0.00	0.01
10	0.40	0.25	0.84	0.75	0.01	0.01
11	0.00	0.07	0.00	0.21	0.00	0.00
12	0.00	0.50	0.00	1.50	0.00	0.01

- Note: 1. PHP_B is the tenant B's proportion of the main air source heat pump energy output.
2. PCP_B is the tenant B's proportion of the circulation pump load.
3. E_{ASHP} is the electricity consumption of the main air source heat pump.
4. E_{CP} is the electricity consumption of the circulation pump.
5. ASHP is the main air source heat pump.
6. CP is the circulation pump.

temperature would be a measured value, just as the return temperatures in the tenant branches. This will offer a more accurate representation of the system, as this measures the real temperature. The calculation of T_{m2}

Table 7
 Tenant C proportioning and cost for main heat pump and circulation pump.

No. of Readings	PHP _C	PCP _C	E _{ASHP} (kW)	E _{CP} (kW)	ASHP Cost (£)	CP Cost (£)
1	0.00	0.00	0.00	0.00	0.00	0.00
2	0.00	0.00	0.00	0.00	0.00	0.00
3	0.33	0.33	5.23	1.00	0.04	0.01
4	0.50	0.33	3.49	1.00	0.03	0.01
5	0.00	0.14	0.00	0.43	0.00	0.00
6	0.33	0.33	6.98	1.00	0.06	0.01
7	0.00	0.25	0.00	0.75	0.00	0.01
8	0.00	0.00	0.00	0.00	0.00	0.00
9	0.00	0.00	0.00	0.00	0.00	0.00
10	0.60	0.38	1.26	1.13	0.01	0.01
11	0.00	0.50	0.00	1.50	0.00	0.01
12	0.00	0.50	0.00	1.50	0.00	0.01

Note: 1. PHP_C is the tenant C's proportion of the main air source heat pump energy output.
 2. PCP_C is the tenant C's proportion of the circulation pump load.
 3. E_{ASHP} is the electricity consumption of the main air source heat pump.
 4. E_{CP} is the electricity consumption of the circulation pump.
 5. ASHP is the main air source heat pump.
 6. CP is the circulation pump.

Table 8
 Billing for one hour of operation.

Users	ASHP (£)	CP (£)	Total (£)
Tenant A	0.20	0.13	0.32
Tenant B	0.14	0.08	0.22
Tenant C	0.14	0.07	0.21
Landlord	0.48	0.28	0.75

Note: 1. ASHP is the main air source heat pump.
 2. CP is the circulation pump.

can be made more accurate, such as including formulas that considers heat losses in the pipework, however for the highest level of accuracy the temperature T_{m2} should be obtained by an actual meter reading such as by a Class 1 Type T thermocouple with an accuracy of ± 0.5 °C [13].

The methodology successfully analyses how the tenant WSH modes (heating, cooling, off) balance the energy between them. The information is then used to understand whether or not the main heat pump needs to operate and if it needs to supply the ambient loop with heating or cooling, and the quantity of energy.

The calculation methodology was simplified in some respects. The energy consumption by the circulation pump is assumed to be constant at 3 kW, except for the case where the whole system is not operating. The input of electricity to the circulation pump in an actual application will be relatively easy to obtain, with an electricity meter on the electrical supply to the circulation pump. Electricity meters will be Measuring Instruments Directive (MID) approved and certified. Where meters serve residential areas, they will be compliant with MID 2014/32/EU, Annex V (MI-003), Class A Meters. Where meters serve commercial/retail areas, they will be compliant with MID 2014/32/EU, Annex V (MI-003), Class B Meters [14]. The complexity lies within the proportioning of the energy that has been shared between tenants, and the calculation methodology can demonstrate this with an arbitrary input.

The calculation methodology was also simplified with regards to the flow rates. In the calculation methodology, the flow rate was arbitrarily set at $0.001 \text{ m}^3/\text{s}$ to and from each tenant. The flow rate in the ambient loop was set at $0.003 \text{ m}^3/\text{s}$. For more in-depth research, the actual required flow rate for the appliances can be achieved by using thermal load analysing software, however for the purpose of feasibility in this research an arbitrary value was considered to be sufficient.

The calculation methodology developed in this study is a theoretical approach under ideal conditions, i.e. no heat loss for water circulating in the ambient loop and tenant branch. In reality, although the pipes are

well insulated, there will still be a certain amount of heat loss that can be calculated using the guidance in CIBSE Guide C [15]. The theoretical analysis of heat loss from pipes is complicated and can be done under specific design conditions. The heat loss depends on various pipe design and installation conditions: (1) diameter of pipe, material of pipe, length of pipe run, (2) bore pipe or insulated pipe, (3) orientation of pipe (horizontal or vertical), (4) installation of pipes (either freely exposed to the surrounding air or buried), (5) air velocity for pipes freely exposed to the surrounding air and (6) water temperature inside the pipe and temperature of the medium that the outer surface of the pipe is exposed to. Alternatively, a Heat Loss Calculator is available from industry that can be used [16]. To minimize the heat loss from pipes, it is essential to insulate the pipework well [17,18]. The calculation of the total energy requirement for the main ASHP may be more accurate if the pipe heat losses are considered, however for the highest level of accuracy the total energy requirement should be obtained by an actual heat meter reading. In the UK, the Office of Gas and Electricity Markets (Ofgem) requires all heat meters to conform to MID 2014/32/EU, Annex VI (MI-004) and meet Class 2 accuracy requirements within EN 1434 [14,19,20].

6.5. Cost and energy savings

If done right, an accurate metering and billing system can offer multiple benefits and opportunities for both landlord and tenants. The landlord will have lower running costs, compared with a system where there is no heat exchange between users of the ambient loop.

Comparing the initial installation costs of conventional gas boiler water heating systems and ambient loop systems, the main cost difference is due to the heat pumps that are used in the ambient loop system rather than the boilers and radiators which are used in conventional water heating systems. Although the average initial installation cost of £13,000 for a heat pump is much higher than the average of £2250 for a conventional gas boiler, heat pumps are much more energy efficient than conventional boilers, and their services cost much less [21,22]. In order to achieve zero-carbon emissions in the UK by 2050 and to help property owners overcome the upfront cost of low-carbon heating technologies such as heat pumps, the UK government provides grants through the Boiler Upgrade Scheme (BUS) of £5000 for ASHPs and £6000 for WSHPs [23]. Life cycle cost analysis enables the investigation of the economic viability of the ambient loop and is the natural next step for future studies.

Annual services for the main ASHP and tenant WSHPs are required to ensure that they operate efficiently. Heat pumps rarely require maintenance work outside of these annual services [17,18]. In case the compressor wears out over time, the costs of either changing to a new compressor or a new heat pump will be considered. The manufacturer is responsible for replacing the parts of the heat pump during the warranty period free of charge. The average cost of servicing a heat pump in the UK is around £180 in 2022 [21]. Modern heat pumps can last for 20 to 25 years [17,18]. With heat pumps that are well maintained, the ambient loop system can be expected to run for 20 to 25 years.

Users connected to the ambient loop can also benefit financially from the fact that they exchange heat with one another. The less the tenants/end users cause the main ASHP to operate, the cheaper their bill is. This concept can potentially be taken one step further. If the tenants are able to view the status of the ambient loop system in real time and understand how their own behavior affects the ambient loop and the main ASHP, certain behavior can be incentivised by using 'free' heating/cooling.

The concept of reducing energy bills for landlords and tenants is of course a strong selling argument, but what is also important to recognize is the savings in energy as well. Energy exchange between tenants is one solution that minimises the energy losses from systems discharging heating or cooling energy to the atmosphere. This energy is lost, but in the ambient loop system it serves a purpose.

7. Conclusion and future work

The methodology and modelling results detailed in this study will contribute towards on-going research and development in the building services industry associated with accurate metering and billing of ambient loop systems.

The methodology developed in this study demonstrates application of a metering and billing solution to an ambient loop system condensed down to three tenants that are served by a main ASHP. However, the same approach applies regardless of the number of tenants using the ambient loop.

The methodology and results focus on a theoretical analysis of how the tenants use the ambient loop for one hour. For the purposes of this analysis, various operational modes are assumed during the selected time period. The results show the final bill and energy consumed for the tenants and the landlord for the one-hour period, accurately metered and billed. A more detailed study would provide additional data that can be analysed to produce a better understanding of the potential monetary and carbon savings that ambient loop systems can offer. It is suggested that the methodology developed in the study can be applied to an actual project so that real apartments and thermal load profiles can be used.

This study demonstrates a theoretical approach to achieving an accurate metering and billing strategy for an ambient loop system. This could bring potential savings in carbon, energy and economic aspects; however, this study only analyses one of many opportunities to do so. This study helps the industry to understand that the ambient loop system is a potential way forward towards achieving net zero carbon, however, in order to understand the full benefits of the system, it would be of great interest to see how the ambient loop system compares to other types of systems commonly used today and evaluate the embodied carbon as well as operational carbon by conducting more extensive and holistic life cycle analyses.

Declaration of Competing Interest

The authors declare that they have no known competing financial interests or personal relationships that could have appeared to influence the work reported in this paper.

Data availability

No data was used for the research described in the article.

Acknowledgments

Sincere thanks to Mr Trevor Leitao for his contribution on building automation and control.

References

- [1] IPCC (2014) Climate change 2014: synthesis report. Contribution of working groups I, II and III to the fifth assessment report of the intergovernmental panel on climate change [Core writing team, R.K. Pachauri and L.A. Meyer (eds.)].
- [2] Energy Research Partnership (2016) Heating buildings reducing energy demand and greenhouse gas emissions. Available from: <https://erpuk.org/wp-content/uploads/2017/01/ERP-Heating-Buildings-report-Oct-2016.pdf> [Accessed 18 June 2022].
- [3] M. Rashad, N. Khordehgh, A. Żabnienska-Góra, L. Ahmad, H. Jouhara, The utilisation of useful ambient energy in residential dwellings to improve thermal comfort and reduce energy consumption, *Int. J. Thermofluids* 9 (2021), 100059.
- [4] H. Jouhara, A. Żabnienska-Góra, N. Khordehgh, D. Ahmad, T. Lipinski, Latent thermal energy storage technologies and applications: a review, *Int. J. Thermofluids* 5 (6) (2020), 100039.
- [5] K.M. Koukou, G. Dogkas, Gr.M. Vrachopoulos, J. Konstantaras, C. Pagkalos, N. V. Stathopoulos, K.P. Pandis, K. Lymperis, L. Coelho, A. Rebola, Experimental assessment of a full scale prototype thermal energy storage tank using paraffin for space heating application, *Int. J. Thermofluids* 1 (2) (2020), 100003.
- [6] C. Pagkalos, G. Dogkas, K.M. Koukou, J. Konstantaras, K. Lymperis, Gr. M. Vrachopoulos, Evaluation of water and paraffin PCM as storage media for use in thermal energy storage applications: a numerical approach, *Int. J. Thermofluids* 1 (2) (2020), 100006.
- [7] G. Dogkas, K.M. Koukou, J. Konstantaras, C. Pagkalos, K. Lymperis, V. Stathopoulos, L. Coelho, A. Rebola, Gr.M. Vrachopoulos, Investigating the performance of a thermal energy storage unit with paraffin as phase change material, targeting buildings' cooling needs: an experimental approach, *J. Thermofluids* 1 (2) (2020), 100027.
- [8] S. Buffa, M. Cozzini, M. D'Antoni, M. Baratieri, R Fedrizzi, 5th generation district heating and cooling systems: a review of existing cases in Europe, *Renew. Sustain. Energy Rev.* 104 (2019) 504–522.
- [9] C. Marques, C. Dunham, P. Jones, R. Matabuena, A. Revesz, H. Lagoeiro, G. Maidment, Integration of high temperature heat network with low carbon ambient loop systems, in: 2021 ASHREA Winter Virtual Conference. Chicago 09-12 February 2021. American Society of Heating, Refrigerating and Air-Conditioning Engineers (ASHREA), 2020. Available from, <https://openresearch.lsbu.ac.uk/download/be0db9d8b81a6363536871d3609075df878af825b76ee7b28e8c7bc5d50764c0/1381561/Integration%20of%20high%20temperature%20heat%20networks%20with%20low%20carbon%20ambient%20loop%20systems.pdf> [Accessed 18 Feb. 2022].
- [10] A. Revesz, P. Jones, C. Dunham, A. Riddle, N. Gatensby, G. Maidment, Ambient loop district heating and cooling networks with integrated mobility, power and interseasonal storage, *Building Services Eng. Res. Technol.* 43 (3) (2022) 333–345.
- [11] M. Boles, Y. Cengel, *Thermodynamics – An Engineering Approach*, 8th ed., McGraw-Hill Education, 2015.
- [12] Department for Business, Energy & Industrial Strategy and Office for Product Safety and Standards (2014) The heat network (Metering and Billing) regulations 2014. Available from: <https://www.gov.uk/guidance/heat-networks> [Accessed 20 June 2022].
- [13] TC Direct, TC direct for temperature sensing, Measurement and Control (2022). Available from, <https://www.tcdirect.co.uk/thermocouple-sensors/thermocouple-accuracies.aspx> [Accessed 12 September 2022].
- [14] European Parliament and of the Council (2014) Measuring instruments directive 2014/32/EU. Available from: <https://www.legislation.gov.uk/eu/eur/2014/32/contents#> [Accessed 12 September 2022].
- [15] CIBSE, Guide C: reference data, The Chartered Institution of Build. Services Eng. London (2007).
- [16] CarbonDescent (no date) Heat Network Heat Loss Calculator. Available from: <https://heatlosscalculator.carbondescent.org.uk/doc/calculating/pipedata> [Accessed 12 September 2022].
- [17] The Scottish Government (2010) A low carbon equipment and building regulations-a guide to safe and sustainable construction air source heat pumps.
- [18] The Scottish Government (2010) A low carbon equipment and building regulations-a guide to safe and sustainable construction ground source heat pumps and water source heat pumps.
- [19] The Office of Gas and Electricity Markets (2019) Renew heat incentive frequently asked questions –meeting. Available from: https://www.ofgem.gov.uk/sites/default/files/docs/2019/03/non-domestic_rhi_-_metering_faq_applicants_applied_before_24_sept_2013_-_updated_2019.pdf [Accessed 12 September 2022].
- [20] The British Standards Institution (2019) EN 1434 - Heat Meters.
- [21] TradesmenCosts (no date) Air source heat pump servicing cost: 2022 price guide UK. Available from: <https://tradesmencosts.co.uk/air-source-heat-pump-servicing/> [Accessed 12 September 2022].
- [22] Heatable (no date) Heat pumps vs gas boilers: cost, efficiency and carbon – footprints. Available from: <https://heatable.co.uk/boiler-advice/heat-pumps-vs-gas-boilers> [Accessed 12 September 2022].
- [23] Department for Business, Energy & Industrial Strategy, Boiler Upgrade Scheme, 2022. Available from, <https://www.gov.uk/guidance/check-if-you-may-be-eligible-for-the-boiler-upgrade-scheme-from-april-2022> [Accessed 12 September 2022].