

PAPER • OPEN ACCESS

Effect of wood structure geometry during firebrand generation in laboratory scale and semi-field experiments

To cite this article: D P Kasymov *et al* 2021 *J. Phys.: Conf. Ser.* **1867** 012020

View the [article online](#) for updates and enhancements.



IOP | ebooks™

Bringing together innovative digital publishing with leading authors from the global scientific community.

Start exploring the collection—download the first chapter of every title for free.

Effect of wood structure geometry during firebrand generation in laboratory scale and semi-field experiments

D P Kasymov^{1,2}, M V Agafontsev^{1,2}, V A Tarakanova^{1,2}, E L Loboda^{1,2},
P S Martynov^{1,2}, K E Orlov¹ and V V Reyno²

¹ Tomsk State University, Tomsk, Russia

² V.E. Zuev Institute of Atmospheric Optics SB RAS, Tomsk, Russia

E-mail: denkasymov@gmail.com

Abstract. As the set of experiments result, statistically substantiated data were obtained on the laws of ignition of a model angular structure under conditions of a point source of heat exposure. The use of IR diagnostics made it possible to control the thermal picture in the experimental area, as well as to capture areas of the highest and lowest heating. In the Large Aerosol Chamber of IAO SB RAS, preliminary experiments were carried out on a “firebrand shower” model exposure, which is naturally occurring firebrands (flaming or glowing embers) with some types of construction materials (chipboards). The exposure of the samples to firebrands stream was provided using a firebrand generator of own original design. It was experimentally confirmed that particle size plays a significant role in the ignition of a building structure. If the characteristic particle size, which can be defined as the ratio of its volume to the surface area in contact with the wood, is less than a certain characteristic value, then the ignition mode with a sharp temperature maximum near the phase interface is not fulfilled. This can be explained by the prevailing heat removal into the external environment in comparison with the amount of heat coming from a heat gun and resulting from chemical reactions.

1. Introduction

Wildfires are becoming an increasingly serious problem of global importance. There are many recent examples of large wildfires all over the world. Wildfires that spread to urban areas, called Wildland Urban Interface (WUI) fires, are becoming more widespread on many continents of the world [1, 2]. This is associated with people's preferences to live in forest areas, as well as a lack of understanding of the transition mechanism to urbanized areas. Two recent examples are the fires in South Korea (2019) and the fires in Northern California in the United States (2018). These wildfires, which destroyed more than 18,804 buildings with fatalities, demonstrated the true power and destruction that wildland-urban interface fires are capable of.

A general feature of large wildfires rapid spread is the heat flux from the fire and the further generation of smaller combustible fragments from the original fire source called firebrands, which are lifted and carried by the wind [3]. This leads to a “firebrand shower” phenomenon.

In the case of wildland-urban interface fires, the formation of firebrands and smoldering particles occurs due to the dynamics of combustion of plant and artificial fuel cells, such as houses and other structures [4].



While particles are responsible for most structural ignition in wildland-urban interface fires [5–9], there are no scientifically based standard laboratory methods for assessing the resistance of individual construction components to ignition from firebrands and smoldering particles. It is impossible to evaluate and compare the performance of construction elements' ability to resist particle ignition without standard laboratory test methods.

The approach to reduce structural ignition under WUI fires concludes for a long time in the development and acceptance of construction rules and standards. These guidelines provide the basis for fire resistant construction in many developed countries around the world [10]. Fire codes and standards for WUI fires remain mostly unproven to actually mitigate the fire spread and structure the ignition processes. The problem is that the science of WUI fire is developed lesser than the field of fire safety science [11].

Investigations of firebrands can be divided into three important areas: particle generation, particle transport, and particle ignition. Many particles researches are focused on the transport of particles. Lesser researches are being done on the generation of particles and their ignition of combustible materials [12–16].

Recent developments in firebrand generators and research using these generators have significantly advanced the understanding of the vulnerability of structures to fire [17]. However, much less progress has been made in understanding particle generation [18]. Understanding the characteristics of particles generated from plant and artificial elements will help to understand the process of particle transport and ignition of structures. For the mechanisms of particle generation from structures, in particular, the wind force plays an important role, since it depends on the applied wind speed. The results obtained in [19] indicate that a higher wind speed leads to the formation of thicker particles with an increase in wind speed.

2. Laboratory setup and experimental procedure

The laboratory setup was assembled to investigate the ignition probability, ignition conditions, and combustion of wood construction materials (figure 1).

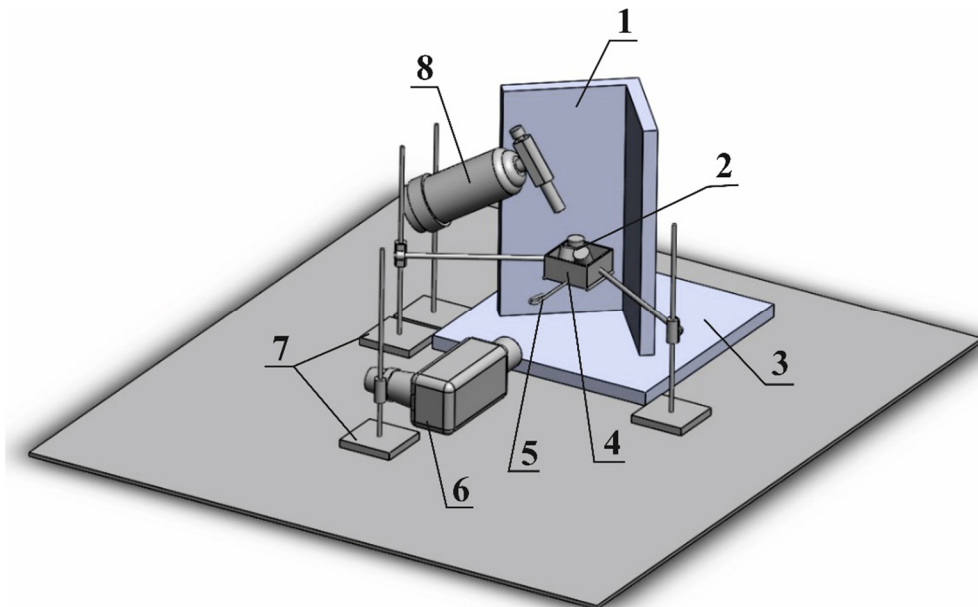

Figure 1. Laboratory setup scheme: 1 – construction sample; 2 – particle samples; 3 – underlying surface; 4 – cell; 5 – stopper; 6 – heat gun; 7 – tripods; 8 – burner.

The building construction was preliminarily prepared. Two samples were stitched together that right angle formed between them (figure 1).

Samples from wood were used as particles (figure 2). Their size coincided with typical sizes of particles determined during field experiments [20]. The moisture content of particles did not exceed 10%. 6–8% was for samples of wood construction materials. Smoldering particles were dropped onto wood samples in the experiments. They were blown with a LODESTAR heat dryer with a stream of heated air at the speed of 5 m/s and temperature of 400 °C. This corresponds to the physics process of a wooden structure exposed to a heat flux from an approaching wildfire front [19, 21].

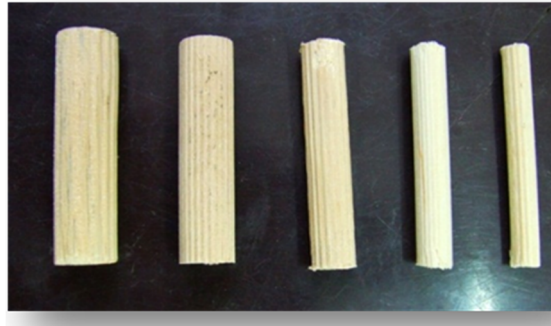

Figure 2. Model particles used in experiments.

An oriented strand board (OSB) with dimensions of 150×300 mm and a thickness of 18 mm was used as sample in the experiments. Particles 2 were placed in a cell 4, fixed on tripods 7 with holes in the base sufficient for uniform particles heating, but excluding the possibility of particles falling out during the experiments. The cell volume made it possible to place both single particles and groups of particles in it. Particles fell onto the wood sample when the sliding bottom of the cell was opened. Parts of the bottom were attached to the walls of the cell with hinges and were fixed in a horizontal position with a stopper 5. When the stopper was extended, the two halves of the bottom fell down under their own weight, and the particles fell onto the object under study. The particles were ignited and brought to a glowing state with a gas burner 8. Then construction 1 was installed on a sample of construction material (OSB) simulating the underlying surface 3, and the particles were dumped.

Experimental equipment involves the following devices: a scientific infrared camera JADE J530SB equipped with an optical filter whose operating wavelength is 3.1–3.3 μm which allows one to record the temperature in the range of 200–800 °C; a video camera Canon HF R88 applied for estimating the ignition delay for considered samples made of wood construction materials; a moisture content analyzer AND MX-50 for controlling moisture content of the studied samples.

2.1. Results and discussion

Figure 3 shows, as an example, a set of ignition and further combustion images of samples of a model angular structure.



Figure 3. Set of images on ignition of a structure made of wood with particles.

The influx of oxidizer into the particle fall zone further the transition from the smoldering phase to the combustion phase of the particles. Active combustion of the particles and the structure surface is taking place. It was found that the structure loses its integrity and insulating ability, the fire transitions to the back of the structure and the underlying surface after two minutes of thermal exposure from the fallen particles.

The thermal picture was analyzed directly in the zone of particle discharge and subsequent interaction with the construction (figure 4) before starting the experiments. Using a JADE J530SB infrared camera, the surface temperature of the construction was measured under conditions of incoming air flow from the heat gun. The maximum temperature of the inner surface of the construction did not exceed 120 °C based on the results of several repetitions.

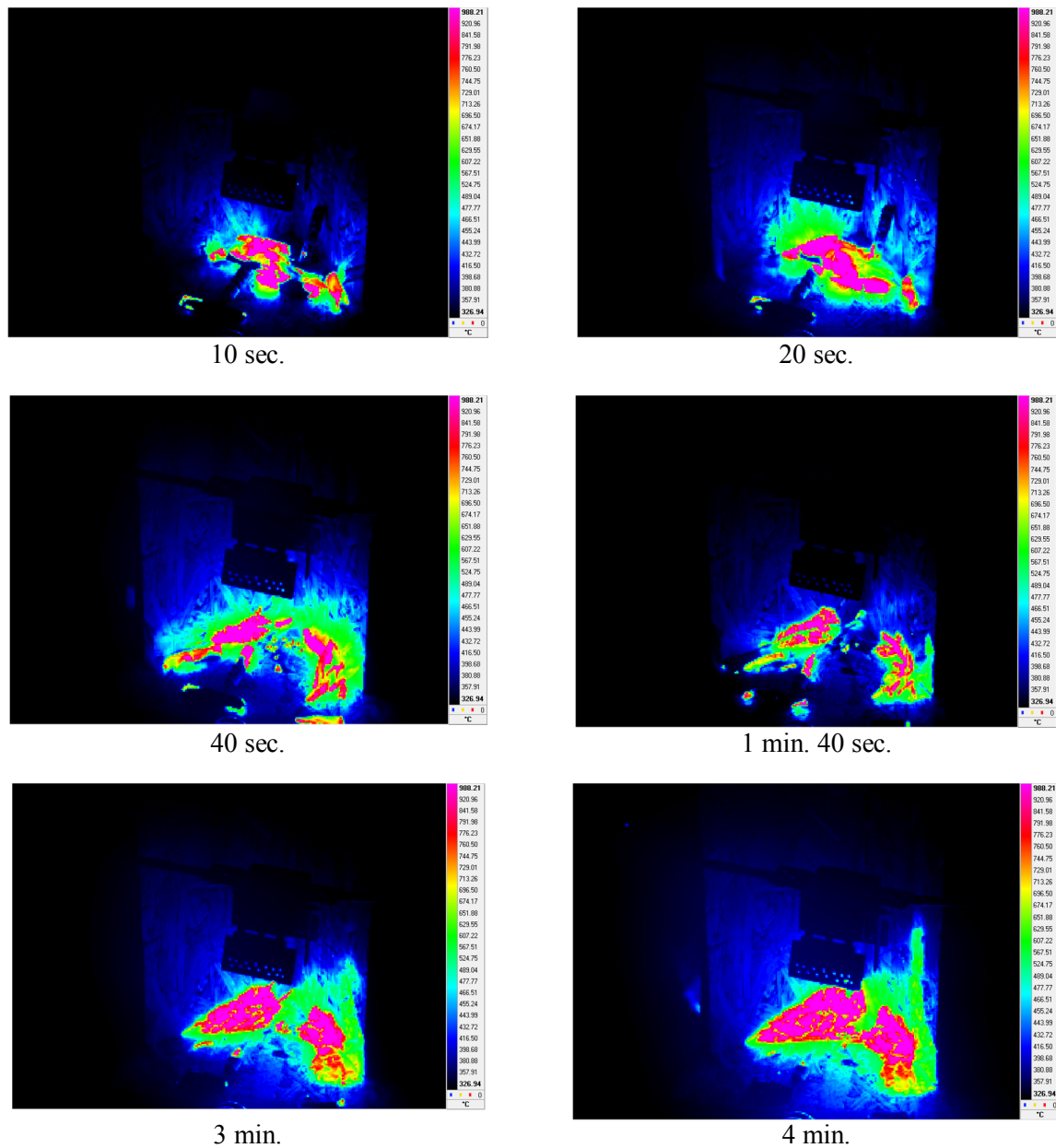

Figure 4. Thermogram of the construction walls heating under the particles exposure at various time.

The particles accumulate near the construction corner after falling (figure 4). But under the air flow exposure from the heat gun, the particles are carried away to the side walls of the construction (figure 4) and continue to interact with the surface of the walls. With prolonged interaction, the energy of the particles is enough to ignite this construction, followed by combustion.

The formation of the air flow vortex was also detected near the sample walls. In its vicinity, most commonly, flame combustion occurs, caused by the influx of an oxidizer. This phenomenon occurs due to the geometry of the structure. Figure 5 shows a thermogram of the particle accumulation process near the walls of the construction corner model. It was experimentally established that 5 particles 6 cm long were sufficient for ignition, followed by stable combustion on the surface of such an angular structure. In other cases, smoldering was observed (for each set of particles, at least 4 repetitions of the experiment were performed).

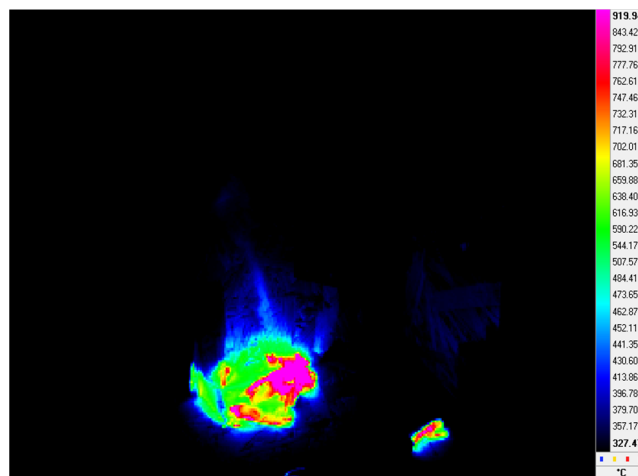

Figure 5. Thermogram of the particle combustion development with the formation of air vortex near the walls.

A comparative analysis of the ignition probability of horizontally fixed construction samples made of wood [22, 23] with a corner construction model was carried out. Preliminary results show that the ignition probability in the case of particles accumulation near the corner construction model increases by more than 50% for the same number of particles. This is probably due to the fact that the samples were preheated for 4 minutes before carrying out the experiments, which corresponds to the physics process of heating the construction from an approaching wildfire front. It was also discovered that the size and number of particles affects the ignition process of the samples.

In addition to studying the interaction of a flat surface with firebrands and smoldering particles, it became possible to study the ignition features of some elements in the construction of buildings and structures (corner structure, roof elements). The data of behaviour and fire-resistance of the samples treated by fire retardants (impregnations) was obtained resulting from the heat exposure.

The obtained data allowed one to judge that according to chosen experimental parameters, the ignition time decreased with increasing air flow, as well as with an increase in the size and number of particles. This dynamic was observed both with and without fire retardant. As a result of an experiment series, statistically valid data on the patterns of ignition of a model angular structure under the conditions of a point source of heat exposure were obtained. The use of IR diagnostics made it possible to control the thermal picture in the experimental zone, as well as to fix the sections of the highest and lowest heating.

3. Experiments in the Large Aerosol Chamber

Carrying out laboratory experiments to study the fire resistance of construction materials and structures during exposure to firebrands and smoldering particles requires comparing the obtained data

with full-scale fire tests. A literature review in this area shows that there are separate uncoordinated scientific groups occupied in semi-field and field tests of the generation and interaction of firebrands and smoldering particles of natural origin with elements of constructions [10, 24–26]. The exposure of the samples to a firebrands stream was provided using a firebrand generator of own original design. As a result, preliminary experiments were carried out on the effect of a “firebrand shower” model – firebrands and smoldering particles of natural origin with some types of construction materials (chipboards).

The experiments were carried out in the Large Aerosol Chamber of Institute of Atmospheric Optics of Siberian Branch of the Russian Academy of Sciences (figure 6). The chamber volume is 2000 cubic meters. Working in this chamber allows one to get rid of the side and head wind effect, which is inevitably present during field work and affects the characteristics of flying particles. JADE J530SB thermal imagers were used with an optical filter 2.5–2.7 μm and a matrix size of 320×240 pixels to record temperature fields, as well as FLIR X6530sc with an operating spectral interval of 1.5–5.1 μm and a matrix size of 640×512 pixels. Factory calibrations were used for all thermal imagers to interpret the recorded radiation into a temperature value.

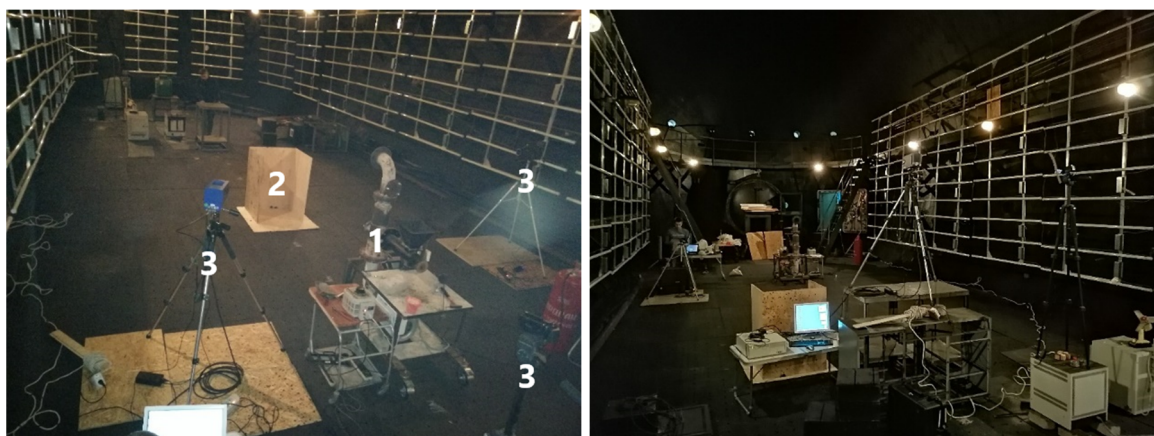

Figure 6. Photo of the experimental site before fire test: 1 – firebrand generator; 2 – wood structure; 3 – measuring equipment.

The experiment was carried out the following way. Sheets of wood-based panels (oriented strand board, chipboard, plywood) were laid on the floor in the area of the highest particles accumulation (figure 7). The considered construction materials had the following characteristics: sheets size 0.6×1.0 m, thickness 12 mm, and density 570-590 kg/m^3 . The moisture content of the samples was controlled using AND MX-50 moisture analyzer before the experiments. Moisture content did not exceed 10% for construction panels. Particles of natural origin (bark and twigs), as well as wood pellets from wood fuel were used as firebrands. Pine twigs with a diameter of 2–4, 4–6, 6–8 mm and lengths of 10, 20, 40 and 60 mm were used as particles of natural origin. The diameter of wood pellets was 8 mm, the length of the pellets was from 30 to 50 mm. The samples were weighed before the start of the experiment to estimate the number of particles with fierily potential. Their number was counted before loading into the generator bunker.



Figure 7. Images of ignition observed for fence and wood decking.

The case of particles accumulation in the adjoining territory, as well as in the roof elements, was simulated in the experiment. This scenario may perform while massive crown fire occurs near residential buildings in a naturally urbanized territory.

3.1. Results

As a result of the experiments, a series of thermal imaging files was obtained, which captured the process of generation and interaction of particles with wood-based panels laid on the floor, as well as near a model pine fence (figure 8). Further data processing was carried out using the Altair software.

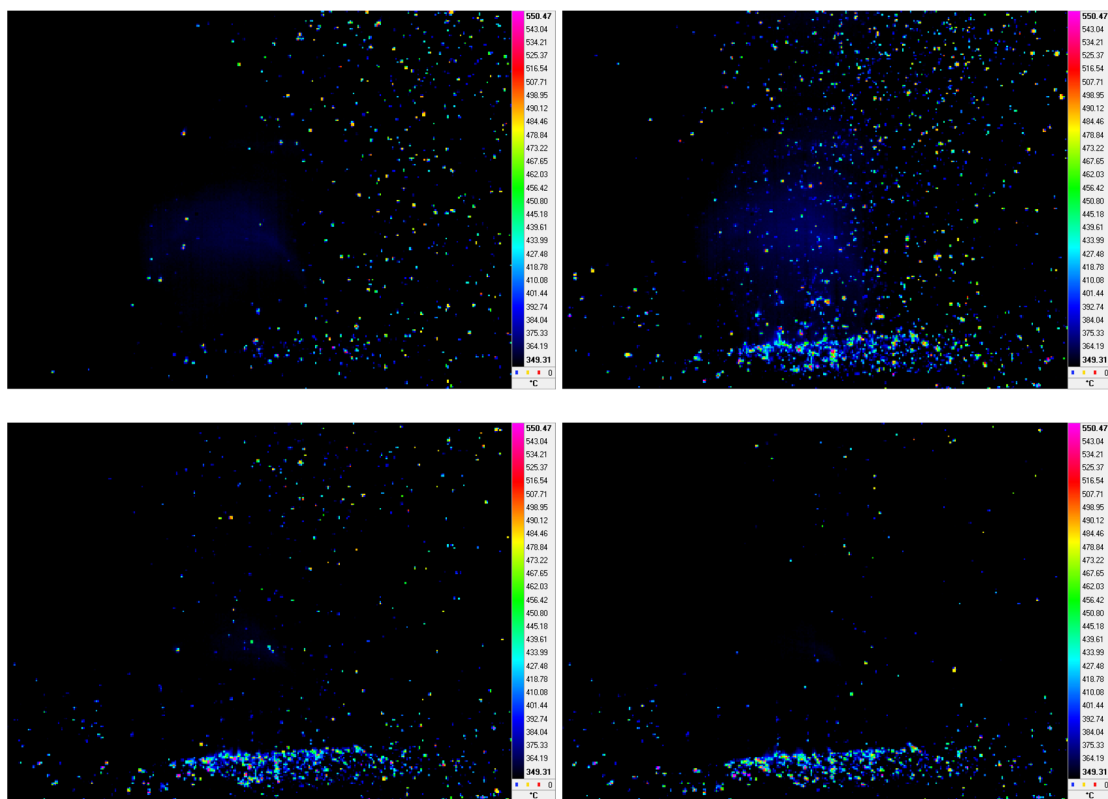

Figure 8. A set of thermograms on the fence ignition.

It was experimentally confirmed that particle size plays a significant role in igniting of building structure. If the characteristic particle size is less than a certain characteristic value, which can be defined as the ratio of its volume to the surface area in contact with wood, then the ignition mode with an abrupt maximum of temperature near the phase boundary is not appear. This can be explained by the prevailing heat removal to the environment compared to the amount of heat coming from the heat gun and resulting from chemical reactions. The characteristic particle size will depend on the specific formulation of the problem and the type of material, its thermal conductivity coefficient, and external factors.

In the Large Aerosol Chamber of IAO SB RAS, preliminary experiments were conducted on the effects of the model “firebrand shower”, which is a firebrands and smoldering particles of natural origin with some types of construction materials (wood boards). The impact on the samples by the flow of burning particles was set using own original designed firebrand generator.

The preliminary results obtained on the probability of ignition of certain types of building structures (flooring, fence, as well as angular building structure) in the conditions of “firebrand shower”.

Among other things, according to the results of analysis of the obtained thermograms, the temperature of the particles at the time of the fall was in the range of 490–650 °C. The temperature at the time of outlet from the burning particles generator was 750–800 °C. It was also noted that the minimum supply of particles required for ignition of wood construction material, which fell in a flame mode in the region of 50×50 mm, was 6–10 units.

Acknowledgement

This research was funded by Russian Science Foundation, grant number 20-71-10068.

References

- [1] Caton S E, Hakes R S P, Gorham D J, Zhou A, Gollner M J 2017 *Fire Technol.* **53** (2) 429–473
- [2] Manzello S (eds) 2020 *Springer, Cham.* DOI:10.1007/978-3-319-51727-8
- [3] Koo E, Pagni P J, Weise D R, Woycheese J P 2010 *Int J Wildl Fire.* **19** 818
- [4] Manzello S L 2019 *J. Comb. Soc.* **61** 96–100 (Japan) 10.20619/jcombsj.61.196_96
- [5] Barrow G J 1945 *Journal of the Council for Scientific and Industrial Research [now CSIRO]* **18** (1) 27–37
- [6] Abt R, Kelly D, Kuypers M 1987 *Fire Technol.* **23** 186–197
- [7] Foote E I D 1994 *M.S. Thesis* University of California, Berkeley 129
- [8] Gordon D. A. 2000 *Berkeley Tunnel Fire: MS thesis* University of California at Berkeley 447
- [9] Maranghides A A, Mell W E 2011 *Fire Technol.* **47** 379–420
- [10] Bryner N P 2019 *Springer, Cham.* 10.1007/978-3-319-51727-8_69-1.
- [11] Manzello S L Almand K, Guillaume E, Vallerent S, Hameury S and Hakkarainen T 2018 *Fire Safety J : FORUM Position Paper* **100** 64–66 10.1016/j.firesaf.2018.07.003
- [12] Fernandez-Pello A C 2017 *Fire Saf. J.* **91** 2–10
- [13] Ellis P F M 2015 *International Journal of Wildland Fire* **24** 225–235
- [14] Fernandez-Pello A C, Lautenberger C, Rich D, Zak C, Urban J, Hadden R, Scott S and Fereres S 2015 *Combustion Science and Technology* **187** 269–295
- [15] Filkov A I, Kasymov D P, Zima V P and Matvienko O V 2016a *AIP Conference Proceedings* **1698** 60004
- [16] Matvienko O V, Kasymov D P, Filkov A I, Daneyko O I and Gorbatov D A 2018 *International Journal of Wildland Fire* **27** 550–561
- [17] Manzello S L 2019 *NIST Special Publication* **1235**
- [18] Filkov A and Prohanov S. 2019 *Fire Technol* **55**, 817–836
- [19] Manzello S L, Hayashi Y, Yoneki T and Yamanoto Y 2010 *Fire Safety Journal* **45** 35–43 DOI:10.1016/J.FIRESAF.2009.09.002
- [20] Filkov A I, Prohanov S A, Mueller E and Kasymov D P 2017 *Proc. of the Combustion Institute*

36 (2) 3263–3270

- [21] Long A, Hinton B, Zipperer W, Hermansen-Baez A, Maranghides A and Mell W 13–17 November 2006 *Fire Ecology and Management Congress Proceedings* San Diego. Available at http://www.srs.fs.usda.gov/pubs/ja/ja_long003.pdf [Verified 15 March 2010]
- [22] Kasymov D P, Tarakanova V A, Martynov P S and Agafontsev M V 2019 *Journal of Physics: Conference Series* **1359** (1) article id. 012092 DOI: 10.1088/1742-6596/1359/1/012092
- [23] Kasymov D and Paletsky 2017 *EPJ Web Conf.* **159** 00026 DOI: 10.1051/epjconf/201715900026
- [24] Manzello S L and Suzuki S 2017 *Fire Safety J.* **92** 122–131 DOI: 10.1016/j.firesaf.2017.05.019
- [25] Manzello S L and Suzuki S 2014 *Fire Safety Sci.* **11** 1339–1352. 10.3801/IAFSS.FSS.11-1339
- [26] Koo E, Pagni P J, Weise D R and Woycheese J P 2010 *Int'l J Wildland Fire* **19** 818–843