

Prototype of Drainage Water Level Monitoring System Using Internet of Things (IoT) Based Web

Jaya Sihombing^a, Ariepp Jaenul^{b,*}, Sinka Wilyanti^c, Nadya Putri^d

^aDepartment of Electrical Engineering, Jakarta Global University, Grand Depok City Jl. Boulevard Raya No.2, Depok 16412, Indonesia

^bDepartment of Electrical Engineering, Jakarta Global University, Grand Depok City Jl. Boulevard Raya No.2, Depok 16412, Indonesia

^cDepartment of Electrical Engineering, Jakarta Global University, Grand Depok City Jl. Boulevard Raya No.2, Depok 16412, Indonesia

^dDepartment of Electrical Engineering, Jakarta Global University, Grand Depok City Jl. Boulevard Raya No.2, Depok 16412, Indonesia

*correspondence email : ariepp@jgu.ac.id

Abstract— Information on water levels needs to be conveyed quickly. So, when the rainfall is high, the supervisory team that monitor the drainage water level needs to be alert move quickly to prevent losses. In addressing these problems, the author will provide a solution in Monitoring of the water level system in the drainage water reservoir so that the operator and maintenance team can find out if there is an over discharge in the drainage water reservoir when the rainfall is very high. By utilizing ultrasonic sensors to detect changes in drainage water level. The ultrasonic sensor used has better reliability than other proximity sensors. In addition, the use of the ultrasonic sensor capability on the prototype is only on the Centimeter scale, and with the help of a buzzer as a reminder indicator (alarm) to find out the water level approaching the sensor. Float switch is also used to determine the water level, namely low, medium and high.

Index Terms— Dainage Water Level Monitoring System, Ultrasonic Sensor, Float Switch Sensor

Abstrak— Penyampaian informasi mengenai ketinggian air perlu dilakukan dengan cepat. Sehingga ketika curah hujan tinggi, tim pengawas yang memonitor ketinggian air drainase perlu sigap dan bergerak cepat untuk mencegah kerugian. Dalam menyikapi permasalahan tersebut penulis akan memberikan solusi dalam Monitoring sistem level air di bak penampungan air drainase agar operator dan tim maintenance dapat mengetahui apabila adanya over debit pada bak penampungan air drainase saat curah air hujan sangat tinggi. Dengan memanfaatkan sensor ultrasonik untuk mendeteksi perubahan ketinggian air drainase. Sensor ultrasonik yang digunakan memiliki kehandalan lebih baik daripada sensor jarak yang lain. Selain itu dalam pemanfaatan kemampuan sensor ultrasonik pada *prototype* hanya dalam skala Centimeter, dan dengan bantuan buzzer sebagai indikator pengingat (Alarm) untuk mengetahui tinggi air yang mendekati sensor. Sensor float switch juga digunakan untuk menentukan level ketinggian air yakni low, medium dan high.

Kata Kunci— Sistem Monitoring Ketinggian Air Drainase, Sensor Ultrasonik, Sensor Float Switch.

I. INTRODUCTION

Indonesia is a country located in Southeast Asia which has two seasons, namely the rainy and dry seasons because it has a tropical climate. In the rainy season, rainfall is very high and can last up to six months [1]. Continuous rain causes an increase in the volume of water, this has the potential to cause flooding in various areas [2], [3] Monitoring the level of rainwater is not too heavy a job, but if there is negligence in monitoring the consequences will be very detrimental because it causes flooding [4], [5], the pump installation system at the underground MRT station is very important to monitor because if the pump does not work optimally during high rainfall the MRT train cannot operate due to water entering the rail line.

In addressing the above problems, the author provides a solution in monitoring the water level system in the drainage water reservoir so that the operator team and the maintenance team can find out information about the water level quickly if there is over discharge in the drainage water reservoir when rainfall is very high. So as to prevent losses for the station and passengers. Direct losses from a natural disaster that occur can be seen from the amount of damage to residential buildings, public facilities, and other infrastructure.

Natural disasters also affect the availability of labor, capital stock and productivity. Therefore, it is hoped that the water level will be easier to monitor and the communication process between the operator and maintenance teams can be integrated into one unit so that decisions can be made quickly and accurately.

In this study the authors use a float switch sensor for setting and controlling the water level as well as an ultrasonic sensor to measure the water level, the ESP8266 MCU node to control the relay based on sensor readings, the ESP8266 MCU node is connected to the same WiFi network and the data will be monitored through the website.

II. METHOD

In this study, researchers used a descriptive method. Descriptive research method is a research method that seeks to describe and interpret objects as they are in accordance with existing conditions. The research flow can be seen in Figure 1 below.

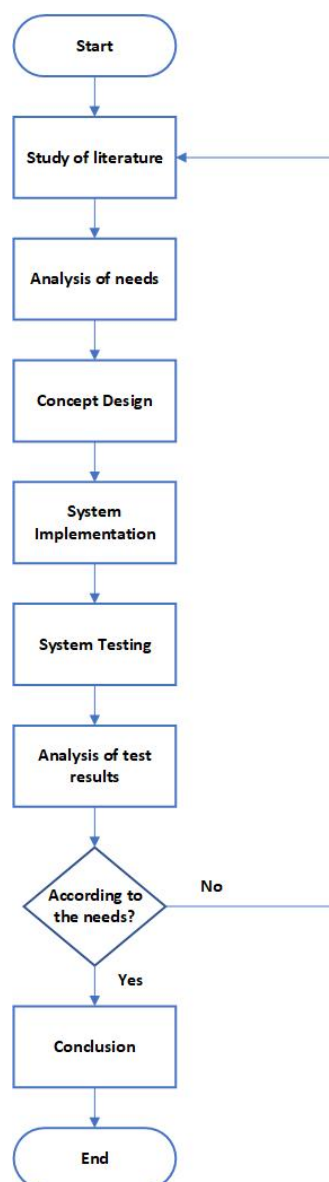

Figure 1. Research flow chart

This study describes a symptom, an event that occurs at the present time or an actual problem. Researchers make a description, or design a prototype of a drainage water level monitoring system such as at the Jakarta MRT underground station to retrieve the analyzed data. The block diagram of the system

created can be seen in Figure 2 below.

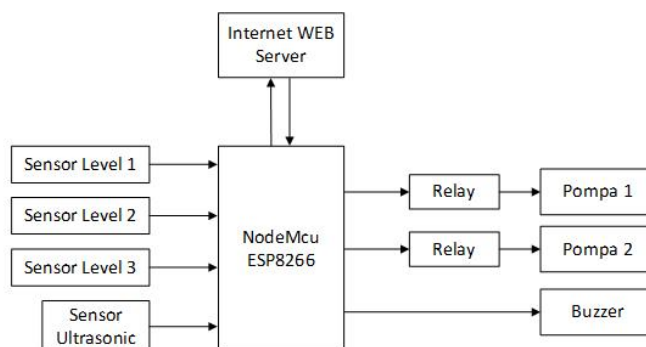

Figure 2. System Block Diagram

The design made in this study as shown in Figure 2 above includes the relationship between sensors, controllers, and actuators.

1. Level Sensor

The level sensor used is a float switch as a device that controls/adjusts the water level in the tub automatically [6], [7]. When the water in the tank exceeds the level limit, the sensor sensing the lowest level of the water will give a signal and then the float switch will give a command to turn on the pump.

2. Ultrasonic Sensor

The ultrasonic sensor as a water level meter will send altitude data which will be sent to the MCU Node as an ultrasonic wave signal and processed into readable data [8], [9].

3. Controller

Nodemcu ESP8266 is a WiFi module that is SOC (System on Chip), so we can do programming directly to the ESP 8266 without the need for an additional microcontroller [10], [11].

4. Actuator

The relay will convert the electrical signal into mechanical movement [12], [13] When the water level has reached a certain limit, the relay will send a mechanical movement that affects the activation of the pump.

III. RESULTS AND DISCUSSION

Hardware design in this research consists of mechanical design and electrical design. The prototype is made of an aquarium as a water reservoir and there are 2 pumps in the aquarium as a drainer as shown in Figure 3. The sensors used are 3 Mechanical Float Switches as a trigger for the water pump and an ultrasonic sensor as a measure of the water level in the container.

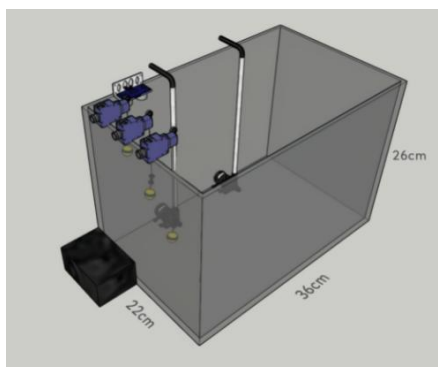

Figure 3. System prototype created

The electrical design of this research includes the working principle of the communication system on the MCU ESP 8266 node with 3 sensor inputs, namely a mechanical float switch 1 sensor for low level, a mechanical float switch 2 sensor for medium level and a mechanical float switch 2 sensor for high level. The results of the electrical design can be seen in Figure 4.

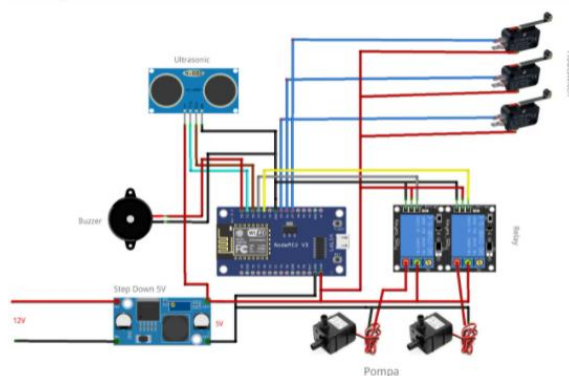

Figure 4. Electrical design

In addition, it is added with 1 ultrasonic sensor as an altitude reader. Then the ESP 8266 sends an output signal, namely a buzzer and 2 relays which will be connected to each pump. To provide power to the microcontroller is given a voltage of about 12V from the battery.

After completion of the electrical design, the program is generally carried out at the final stage. In the programming process, it is generally carried out by means of trials, so to do this the electrical components must be able to operate properly. Programming is entering an information or command (coding) into the microcontroller. It is hoped that the tool will function as planned. In software design, the Esp8266 microcontroller uses Arduino IDE software.

The program that will be made will read the water level detected by the float switch sensor and read the water level value detected by the ultrasonic sensor. The read value will be stored by the ESP8266 then the sensor value will send a signal through the ESP 8266 and sent to the Web using the internet network and users can receive notification information from the web. And here is the display of this sign on the web application that has been developed.

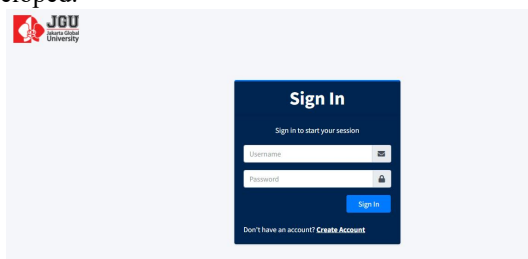

Figure 5. Display sign in to web page

Users can monitor the water level, the condition of the pump in the bath in real time by sending messages via the web according to what the user wants. In addition, the program made is not only monitoring but can also be used as a determination of the water level threshold by displaying an ALARM notification. And in Figure 6 is a web dashboard page display that can be used as real-time monitoring.

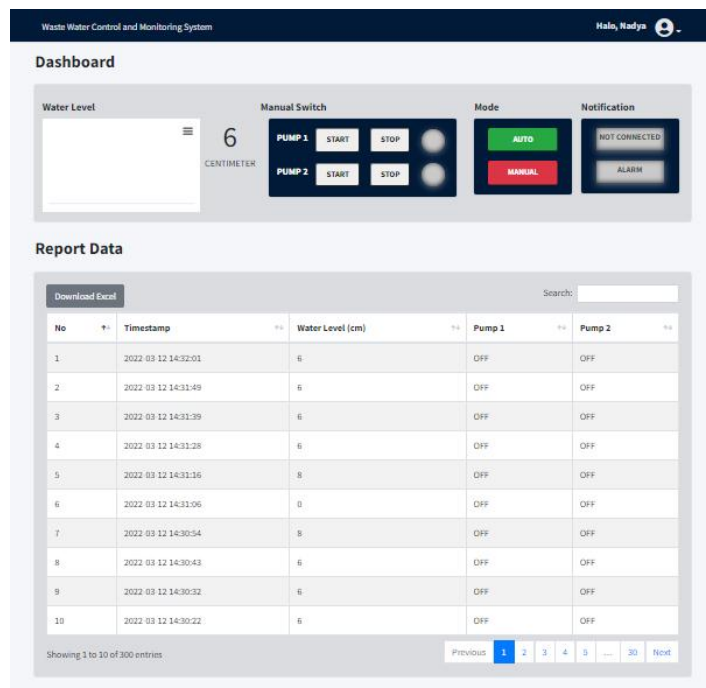

Figure 6. Web dashboard

The next step is testing the float switch sensor which is carried out to determine the pump's work against the water level. Sensor testing is done by pouring water into a box/container starting from a height of 10 cm, 15 cm to more than 20 cm.

Table 1. Level Sensor Test Results (Float Switch)

| Level Sensor Test | Ultrasonic sensor reading height | Pump Condition | |
|-------------------|----------------------------------|----------------|--------|
| | | Pump 1 | Pump 2 |
| Sensor Level 1 | 13 cm | ON | OFF |
| Sensor Level 2 | 16 cm | ON | ON |
| Sensor Level 3 | 22 cm | ON | ON |

Based on table 1, the results of the level sensor test carried out to test the pump's work against the water level appeared 3 conditions where 1 pump worked when the water level was 13 cm, then 2 pumps worked when the height was 16 cm and 2 pumps were turned on when the water level was 22 cm.

Tests were also carried out on ultrasonic sensors to detect water levels. To test the ultrasonic sensor is done by comparing two ultrasonic sensors and using a meter to measure the actual water level. The ultrasonic sensor test results are shown in table 2.

Table 2. Ultrasonic Sensor Test Results

| Actual water level | Sensor water level | Deviation | Error (%) |
|--|--------------------|-----------|-------------|
| 12,6 | 13 | 0,4 | 0,03 |
| 16 | 16 | 0 | 0 |
| 20,5 | 22 | 1,5 | 0,07 |
| <i>Average ultrasonic sensor error 1</i> | | | <i>0,03</i> |
| 13,3 | 13,27 | 0,03 | 0,002 |
| 16,5 | 16,47 | 0,03 | 0,001 |

| Actual water level | Sensor water level | Deviation | Error |
|--|--------------------|-----------|---------------|
| | | | (%) |
| 20,8 | 20,74 | 0,06 | 0,002 |
| <i>Average ultrasonic sensor error 2</i> | | | <i>0,0017</i> |

Based on table 2 above, the level of accuracy of the ultrasonic sensor work is obtained by the following calculations:

a. Ultrasonic Sensor Accuracy 1

$$\text{Accuracy (\%)} = 100\% - (\text{ultrasonic sensor error average}) \quad (1)$$

$$\text{Accuracy (\%)} = 100\% - 0,03\% \quad (2)$$

$$\text{Accuracy (\%)} = 99,97\% \quad (3)$$

b. Ultrasonic Sensor Accuracy 2

$$\text{Accuracy (\%)} = 100\% - (\text{ultrasonic sensor error average}) \quad (4)$$

$$\text{Accuracy (\%)} = 100\% - 0,006\% \quad (5)$$

$$\text{Accuracy (\%)} = 99,99\% \quad (6)$$

From the ultrasonic sensor test results, it can be seen that ultrasonic sensor 1 and ultrasonic sensor 2 are accurate, as evidenced by the results of measuring water level manually with a ruler/meter only has an average error of 0.016%.

IV. CONCLUSION

A prototype of a drainage water level monitoring system using a web-based Internet of Things (IoT) has been successfully developed in this research. In this study, the ultrasonic sensor readings were very accurate, as evidenced by the test results by comparing the results read on the web and the results measured manually using a meter only experienced an average error of 0.016%. Furthermore, the use of float sensors can work according to the design, where the lowest float switch becomes the low-level threshold, the middle float switch becomes the medium level threshold and the top float switch becomes the high-level threshold. However, this research needs to be improved, especially in terms of monitoring it can be equipped with automatic notifications on the computer (PC) to give notice that the water level is already at a medium level to a high level, so that before the officer opens the web, the monitoring officer has been informed through the message.

ACKNOWLEDGMENT

The authors would like to acknowledge the support from Jakarta Global University throughout this project. This project has been funded by the Ministry of Education, Culture, Research and Technology under the scheme of Research of Early Career Lecturer (PDP) No. 0267/E5/AK.04/2022.

REFERENCES

- [1] M. Saeri, N. Hanani, B. Setyawan, and D. Koestiono, "TECHNICAL EFFICIENCY OF RICE FARMING DURING RAINY AND DRY SEASONS IN NGAWI DISTRICT OF EAST JAVA PROVINCE, INDONESIA," *Russ. J. Agric. Socio-Economic Sci.*, vol. 91, no. 7, pp. 270–277, Jul. 2019, doi: 10.18551/rjoas.2019-07.31.
- [2] C. Han, J. Huo, Q. Gao, G. Su, and H. Wang, "Rainfall monitoring based on next-generation millimeter-wave backhaul technologies in a dense urban environment," *Remote Sens.*, vol. 12, no. 6, 2020, doi: 10.3390/rs12061045.
- [3] D. S. Rani, G. N. Jayalakshmi, and V. P. Baligar, "Low Cost IoT based Flood Monitoring System Using Machine Learning and Neural Networks: Flood Alerting and Rainfall Prediction," *2nd Int. Conf. Innov. Mech. Ind. Appl. ICIMIA 2020 - Conf. Proc.*, no. Icimia, pp. 261–267, 2020, doi: 10.1109/ICIMIA48430.2020.9074928.
- [4] M. Acosta-Coll, F. Ballester-Merelo, M. Martinez-Peiró, and E. De la Hoz-Franco, "Real-time early warning system design for pluvial flash floods—a review," *Sensors (Switzerland)*, vol. 18, no.

- 7, 2018, doi: 10.3390/s18072255.
- [5] D. Satria, S. Yana, R. Munadi, and S. Syahreza, "Design of information monitoring system flood based internet of things (Iot)," *Emerald Reach Proc. Ser.*, vol. 1, pp. 337–342, 2018, doi: 10.1108/978-1-78756-793-1-00072.
- [6] R. S. Assendelft and H. J. Ilja van Meerveld, "A low-cost, multi-sensor system to monitor temporary stream dynamics in mountainous headwater catchments," *Sensors (Switzerland)*, vol. 19, no. 21, 2019, doi: 10.3390/s19214645.
- [7] I. Mohanraj, K. Ashokumar, and J. Naren, "Field Monitoring and Automation Using IOT in Agriculture Domain," *Procedia Comput. Sci.*, vol. 93, no. September, pp. 931–939, 2016, doi: 10.1016/j.procs.2016.07.275.
- [8] I. I. Setiawan, A. Jaenul, and D. Priyokusumo, "Prototipe Sistem Keamanan Rumah Menggunakan Face Recognition Berbasis Raspberry Pi 4 Prototype of Home Security System Using Face," pp. 496–501, 2020.
- [9] K. E. Supriya, "IoT based real time water level monitoring using Texas instruments' CC3200," *Indian J. Sci. Technol.*, vol. 13, no. 17, pp. 1720–1729, 2020, doi: 10.17485/ijst/v13i17.295.
- [10] A. Pangestu, M. N. Mohammed, S. Al-Zubaidi, S. H. K. Bahrain, and A. Jaenul, "An internet of things toward a novel smart helmet for motorcycle: Review," *AIP Conf. Proc.*, vol. 2320, no. March, 2021, doi: 10.1063/5.0037483.
- [11] A. Diriyana *et al.*, "Water Level Monitoring and Flood Early Warning Using Microcontroller With IoT Based Ultrasonic Sensor," *J. Tek. Inform. C.I.T.*, vol. 11, no. 1, pp. 22–28, 2019, [Online]. Available: www.medikom.iocspublisher.org/index.php/JTI.
- [12] A. Pangestu, M. Yusro, W. Djatmiko, and A. Jaenul, "THE MONITORING SYSTEM OF INDOOR AIR QUALITY BASED ON INTERNET OF THINGS," *SPEKTRA J. Fis. dan Apl.*, vol. 5, no. 2, pp. 141–152, 2020, doi: doi.org/10.21009/SPEKTRA.052.06.
- [13] M. S. Hossain, M. Rahman, M. T. Sarker, M. E. Haque, and A. Jahid, "A smart IoT based system for monitoring and controlling the sub-station equipment," *Internet of Things (Netherlands)*, vol. 7, p. 100085, 2019, doi: 10.1016/j.iot.2019.100085.

Jaya Sihombing. He holds a Bachelor of Engineering (S.T) from Mercu Buana University Yogyakarta in 2007 and a Master of Engineering (M.T) degree in 2012 at Mercu Buana University. Currently active as a permanent lecturer in Electrical Engineering at Jakarta Global University. To communicate, please contact jaya@jgu.ac.id email.

Ariep Jaenul. He holds a Bachelor of Education in Electronics Engineering (S.Pd) from State University of Jakarta in 2017 and a Master of Science in Engineering (M.Sc.Eng) degree in 2019 at Management and Science University. Currently active as a permanent lecturer in Electrical Engineering at Jakarta Global University. To communicate and research collaboration, please contact ariep@jgu.ac.id email.

Sinka Wilyanti. She holds a Bachelor of Engineering (S.T) from Sekolah Tinggi Teknologi Jakarta in 1999 and a Master of Engineering (M.T) degree in 2007 at Sekolah Tinggi Teknologi Jakarta. Currently active as a permanent lecturer in Electrical Engineering at Jakarta Global University. To communicate, please contact sinka@jgu.ac.id email.

Nadya Putri. She is a graduate of the Jakarta Global University Electrical Engineering Study Program in 2022. To communicate, please contact nadya@student.jgu.ac.id email.