

# Prototype-Design of Soil Movement Detector Using IoT Hands-on Application

Reza Diharja<sup>1\*</sup>, Muhammad Reza Fahlevi<sup>1</sup>, Endang Sri Rahayu<sup>1</sup>, Wike Handini<sup>1</sup>

<sup>1</sup>Department of Electrical Engineering, Faculty of Industrial Technology Jayabaya University, DKI Jakarta, Indonesia.

Received: June 2, 2022

Revised: October 15, 2022

Accepted: October 26, 2022

Published: October 31, 2022

Corresponding Author:

Reza Diharja

[reza.diharja@jayabaya.ac.id](mailto:reza.diharja@jayabaya.ac.id)

© 2022 The Authors. This open access article is distributed under a (CC-BY License)



DOI: [10.29303/jppipa.v8i4.1709](https://doi.org/10.29303/jppipa.v8i4.1709)

**Abstract:** The landslide disaster that killed people occurred due to public ignorance of the type of soil prone to landslides. Several efforts have been made to create prototype tools for soil movement detection. However, researchers using the Internet of Things (IoT) technology are still limited. The IoT allows for the transmission of data over an internet connection, is always connected, offers remote control capabilities, and data sharing. All of this served as the prototype design of foundation for the soil movement detection. A light-based proximity sensor is used in system, and its output is represented as a movement of the soil on an inclined plane. Furthermore, the data used as input for the NodeMCU ESP8266 microcontroller is linked to the internet. The output is an HMI in the form of an LCD monitor that displays the soil movement measurement. The simulation of disturbances in an inclined plane is done differently depending on the frequency and duration. Moreover, monitoring is carried out by transferring processed data to the Blynk platform, which is subsequently shown in real time via the Blynk Android application. The test results of the tool used three distinct samples, as well as varied disturbance frequencies and durations. With the soil samples, the biggest movement data was 5cm achieved at a disturbance frequency of 5Hz and 40 seconds duration. The largest movement data for sand samples was 11cm at a disturbance frequency of 3Hz and 50 seconds duration, followed by largest movement data for sand soil mixture samples was 8cm at a disturbance frequency of 5Hz and 50 seconds duration. People should not reside on slopes, especially if the soil's primary component is sand.

**Keywords:** Blynk; IoT; Landslide; NodeMCU ESP8266; Soil Movement

## Introduction

Landslide disasters are among the top three most common disasters in Indonesia, with quite a lot of losses. According to data from the National Disaster Management Agency (Kwon with BNPB), there were 1321 occurrences of landslides in Indonesia until the end of 2021 (Superadmin Data, 2022). Landslides are most common in mountainous terrain, hills, steep slopes, and cliffs. Landslides are caused by two basic factors: the driving factor and the trigger factor. The driving factor is the factor that affects a substance and causes it to move. Meanwhile, the trigger factor is the element that causes the material to shift, resulting in a landslide. The fundamental cause of landslides. However, gravity is pulling the soil down.

Other elements that contribute to landslides include rainfall, geological structure, distance from faults, vegetation levels, and the region's terrain (Wang et al., 2017) Soil erosion, steep cliff slopes, vibrations, sparse trees, and the existence of farms on the slopes are all factors to consider. Landslides occur when there is a mass movement of rocks and soil due to the force of gravity. The landslide occurs when there is an equilibrium disturbance in the restraining force and the launching force operating on the slope (Heru et al., 2019).

Landslide disasters often take the lives of people due to the presence of people in the vicinity and their inability to predict the onset of disasters. The advancement of technology makes information transmission faster, more flexible, and more efficient. IoT is one of the technologies that can be used in the process of exchanging information (Internet of Things).

## How to Cite:

Diharja, R., Fahlevi, M.R., Rahayu, E.S., & Handini, W. (2022). Prototype-Design of Soil Movement Detector Using IoT Hands-on Application. *Jurnal Penelitian Pendidikan IPA*, 8(4), 2245–2254. <https://doi.org/10.29303/jppipa.v8i4.1709>

The Internet of Things (IoT) is a data collection and information transmission concept. The idea is to broaden the benefits of always-on internet access, which includes remote control and data sharing capabilities.

Energy intelligence in the home, manufacturing, logistics, and construction industries, monitoring the environment of healthcare systems and services, and drone-based services are some examples of IoT applications (Naser Hossein, 2020).

### Vibration

Vibration (oscillations) occurs when there is a disturbance from its equilibrium position. A small amount of energy influences vibration as a reciprocating motion around the equilibrium point. The vibration frequency is one full back and forth movement (Navila, 2017). Examples of vibrations in everyday life include 1) The swing of the youngsters being played; 2) The pendulum of the swaying wall clock; 3) Plucked guitar strings. Vibration characteristics include deviation, amplitude ( $A$ ), period ( $T$ ), and frequency ( $f$ ).

$$f = \frac{1}{T} = \frac{n}{T} \text{ (Hz)} \quad (1)$$

The frequency value is influenced by the number of vibrations per second and the duration of such vibrations.

### Waves

Waves are vibrations that carry propagation energy without moving the matter in between. Wave motion is a type of energy transfer in which momentum is transferred from one point to another without the displacement of matter. Wave types are classified according to their medium, amplitude, and propagation direction (Navila, 2017).

There are mechanical and electromagnetic waves based on the medium. Mechanical waves are waves that require an intermediate medium to propagate, such as sound waves, ropes, and slinky. Electromagnetic waves, unlike light waves, radar, radio, and television, do not require a medium to propagate. There are running waves and stationary waves based on amplitude. A running wave is one with the same amplitude at every point. While stationary waves have different amplitudes at different points.

There are several types of waves based on their propagation direction, including transverse and longitudinal waves. Transverse waves, such as rope waves, light, radio, television, and radar, have propagation directions that are perpendicular to the direction of their vibrations. Longitudinal waves are waves whose propagation direction is parallel to their vibration direction, such as sound waves (sound), springs / slinky wavelength ( $\lambda$ ), period ( $T$ ), frequency

( $f$ ), and rapid propagation of waves ( $v$ ) are all wave characteristics (Navila, 2017).

$$v = \frac{\lambda}{T} \text{ (m/s or cm/s)} \quad (2)$$

As a result, the wavelength, frequency, and period of a wave all have a significant impact on its rapid propagation value. Another feature is that waves can be reflected if they pound the barrier wall, and they can be refracted if they pass through different density substances. If waves pass through a narrow gap, they can flex and be combined without interfering with their speed.

Firmansyah et al. previously conducted research on soil movement monitoring systems using the concept of an accelerometer as an early detection of soil movement (Nursuwars et al., 2019). The design uses an accelerometer sensor to detect soil on an inclined plane, which is then connected to a NodeMCU microcontroller that is linked to the Internet and a server, where the results of sensor detection data are stored and displayed via the website.

Naldi and Wildian, (2018) conducted another study on the design of an Earthquake Alarm System Using the principles of Spring Force and Magnetic Field Sensing. The vibration measuring sensor was positioned in the ground and given a permanent magnet in their design. The sensor detection results are then processed by the Arduino Uno microcontroller and displayed on the LCD.

Meisya et al, (2018) conducted a study with the THOR (Landslide Detection): Detection of landslide disasters using SMS gateway-based "prayer beads" sensors.. In their design a prayer bead sensor made of nails and placed on a slope prototype is used. After that, the sensor is connected to the Arduino Mega microcontroller. If a landslide is detected, the prayer bead sensor will send an alert via buzzer and SMS gateway as an early warning of the landslide.

Artha et al, (2018) created a Landslide Disaster Early Warning System Using Accelerometer Sensors and Android-Based Soil Moisture Sensors. The system measures soil vibration with an accelerometer and soil moisture with a soil moisture sensor. Sensor data are then processed by a NodeMCU microcontroller connected to the Internet network, and the processed data is sent from the NodeMCU to a webserver that can be accessed in real time via android.

Parwati et al. (2018) did research on Designing a Landslide Hazard Early Warning System with Hygrometer and Piezoelectric Sensors. A hygrometer sensor detects soil moisture and a piezoelectric sensor measures the load or pressure. The sensors are connected to the ATmega328 microcontroller, which serves as a processor for the measurement data. The

processed results are then sent to the user via SMS gateway using the GSM SIM900 module.

Based on the research referenced above, a prototype of the landslide movement detection system will be designed using an IoT-based Sharp GP distance sensor, which can provide information about the inclined plane's soil movement, such as the distance of the soil movement from the starting point and notification of danger warnings due to the presence of a movement with the potential to landslide. The sensor is used as input to detect inclined soil movement and a buzzer is used as an output to generate alarm sounds warning of potential landslides. The Sharp GP sensor is connected to the NodeMCU ESP8266 microcontroller, which is connected to the Internet. The NodeMCU ESP8266 sends sensor detection data to the blynk platform, which stores the data in realtime and can be accessed via an Android app.

This prototype has two outputs: one uses an LCD as a ground shift information display and the other uses a DC motor to simulate disturbance on the inclined plane. The monitoring system built with NodeMCU ESP 8266 sends sensor detection data to the Blynk platform, which stores data in real time and can be accessed through an Android app.

The number of landslide cases has increased due to public ignorance of soil types that have the potential to cause larger landslides, but efforts to simulate soil movement detection devices using IoT technology are still rare. Based on these issues, a soil movement detection device prototype was created.

**Method**

Figure 1 shows a block diagram of a prototype landslide movement detection system that uses an internet of things-based Sharp GP distance sensor. Physical magnitude data is obtained from the sensor readings and then used as input in the system to determine the presence or absence of soil movement.

As the sensor input data processor, the microcontroller employs the NodeMCU ESP8266. The Kit's development is based on the ESP8266 module, which includes GPIO, PWM (Pulse Width Modulation), I2C, 1-Wire, and an ADC (Analog to Digital Converter) on a single board (Artha et al., 2018). In addition to being a data processor, the microcontroller can communicate with the outside world via an internet connection. The data from the treated sensor is then transmitted via the Internet network to the Blynk web server and displayed on an LCD display. Based on simulated shocks applied to the inclined plane, the LCD display will display soil movement information. Disturbance with several hertz values representing the source of vibration and waves generated by the DC motor.

The DC motor controller or driver is an L298 module that controls the rotational direction of the motor (Adriansyah & Hidyatama, 2016). An Android smartphone with a Blynk application that can pull data from the Blynk Web server and display it in real time on the smartphone screen. The Blynk Apps application is programmed using drag and drop, making it easier to add input / output components without having to know Android or iOS programming (Hadi et al., 2019).

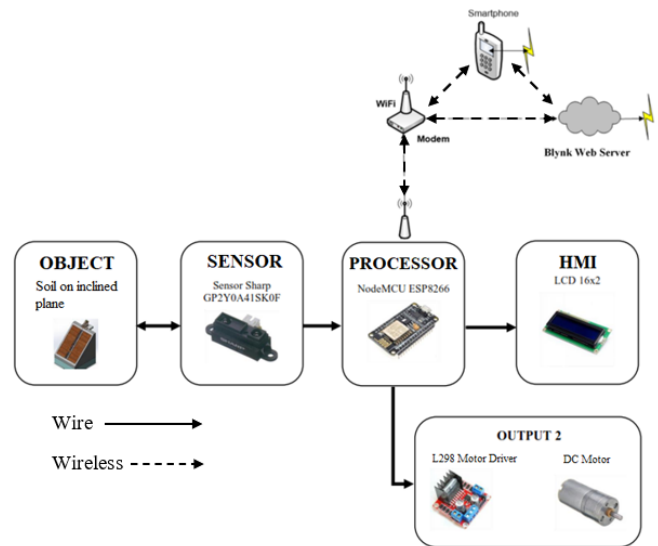

**Figure 1.** Block diagram of the system

Hardware design is divided into two categories: electronic device wiring design and 3D mechanical design. Electronic device wiring design includes input devices, microcontrollers, and outputs based on the ports and pins that will be used to run the tool's prototype. Figure 2 shows the wiring of electronic devices.

Using commercial CAD software, create a 3D mechanical design of the tool. An incline plane simulation medium and an electronic controller box section are included in the design. Step by step, the design and shape of the tool will be perfected over time, particularly the placement of mechanical and electronic components, as shown in Figure 3.

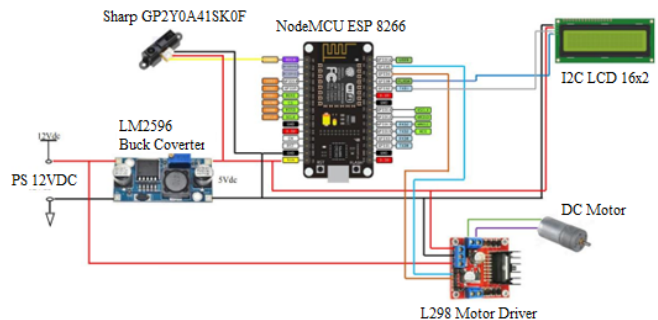

**Figure 2.** Wiring design of the prototype system

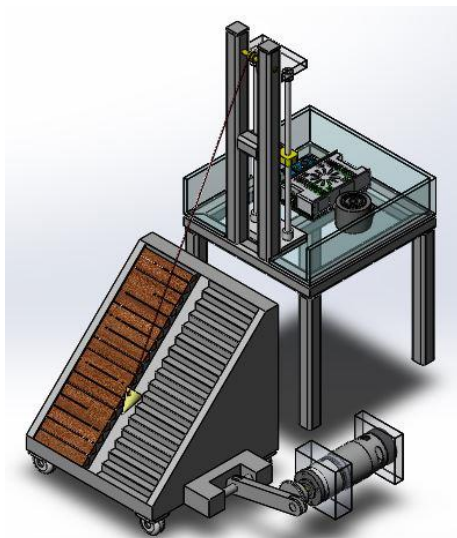

Figure 3. Perspective view of the mechanical design

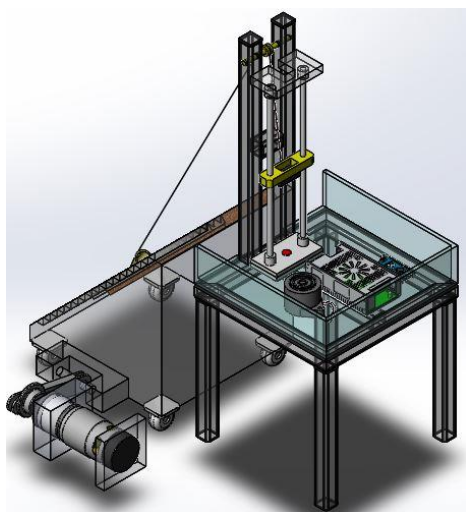

Figure 4. Back-view of the mechanical design

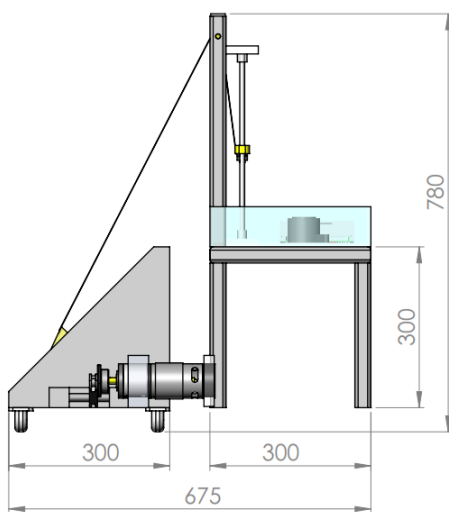

Figure 5. Side-view of the mechanical design with dimension size

The Design Specifications of the Prototype of the Soil Movement Detection System are shown by Table 1.

**Table 1.** Prototype of the Soil Movement Detection System Specification

Specifications	Details
1. Physical Dimension	
a. Length	675mm
b. Width	300mm
c. Height	780mm
d. Weight	±2kg
2. Hardware specifications	
a. Input voltage	12VDC
b. Microcontroller	NodeMCU ESP8266
c. Input sensor	Sharp GP2Y0A41SK0F distance sensor
d. Output	LCD display; Motor DC 12V Gearbox 250rpm 8.8kgcm
e. Display	Android smartphone
3. Software specifications	Arduino IDE; Blynk App
4. Whole Dimension (LxWxH) cm	65 x 40 x 86

Table 1 is the technical specifications of the system. An actuator is used in the system as a source of vibration so that the soil can be simulated as if it is move. The actuator must have sufficient torque and power to ensure that the soil movement simulation does not deviate from the established parameters.

According to Figure 6, the NodeMCU microcontroller programming flowchart begins with the initialization of the ADC input port for the sensor, the DC motor output port, and the LCD I2C port, Wi-Fi IP address network, and Blynk token account. The program also scans the Wi-Fi to ensure that the microcontroller is connected to the internet. When the microcontroller is connected to the internet network and the blynk platform, sensor begins reading the distance to get data and sends it to the blynk web server to be displayed via the blynk application. When the dc motor's on button is pressed, the microcontroller begins to adjust the dc motor's speed to simulate shocks on the inclined plane. When the sensor detects soil movement, the microcontroller sends the data to the LCD display and the Blynk application, which displays it.

According to Figure 7, the Blynk platform programming flow chart begins with the initialization of the Blynk platform account to obtain the Blynk token account, sensor data variables and dc motor on button variable. Second, after connecting the device, the program receives sensor data from the microcontroller and displays them via the Blynk application. Third, when the DC motor on the button is pressed, the Blynk sends high data to the microcontroller, causing the dc motor to activate and simulate shocks in the inclined

plane. Fourth, if the sensor detects soil movement, the Blynk app displays it.

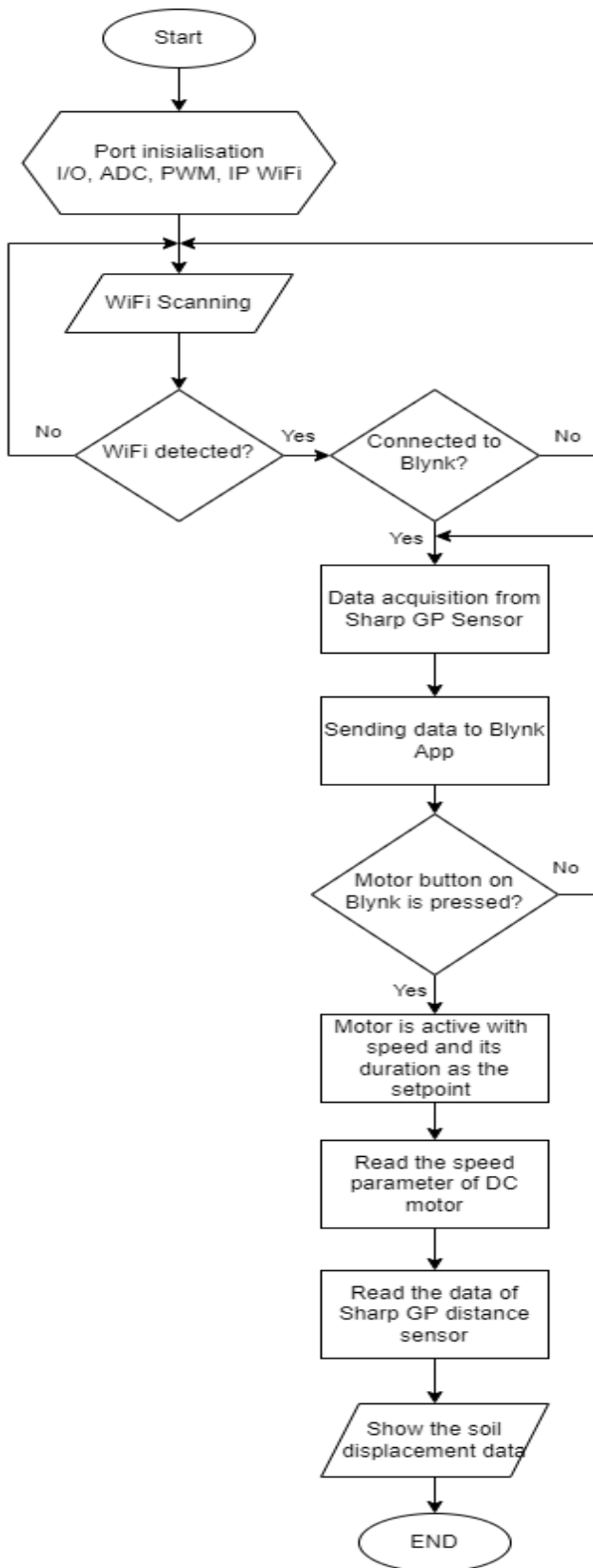

Figure 6. NodeMCU Microcontroller's Programming Flowchart

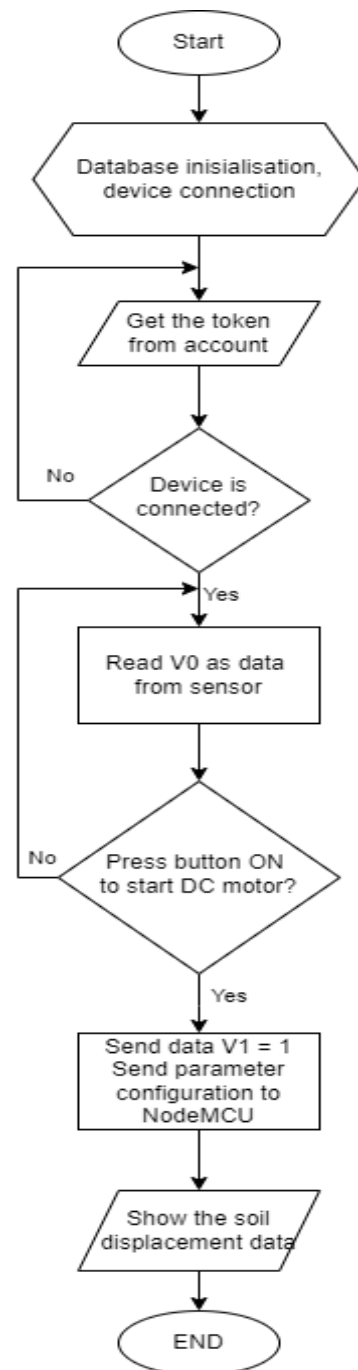

Figure 7. Blynk Platform Programming Flowchart

## Result and Discussion

### Development of Soil Movement Detection System Prototype

Figure 8 depicts the realization of the system prototype, while Figure 9 depicts the interface display on the Blynk application. The Blynk application displays a menu with frequency selection, shift indicators, vibration duration, and shift charts in distance units. The use of frequencies to simulate the state of soil movement in real life. The duration of the vibration is used to

determine how long the vibration lasts when it causes a movement in the ground.



Figure 8. Realization of the System Prototype

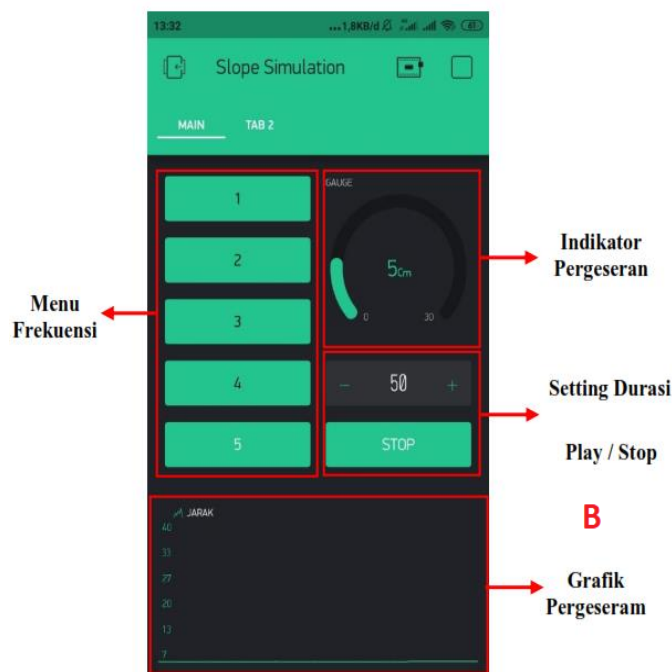





Figure 9. Interface Display on the Blynk Application

*Sample and Characteristics*

The stages described in the flow chart will be applied later using a variety of different variations in soil material. The use of various soil samples aims to determine which type of soil has the greatest potential for harm. Even though it has a low vibration frequency

and a short duration, the potential hazard has a long movement distance. The following Table 3 shows the characteristics of the sample used.

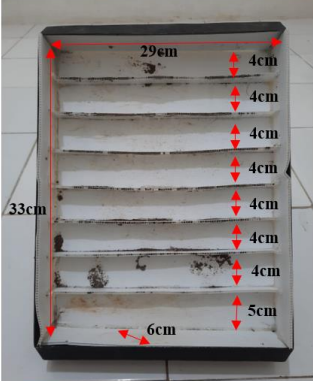

**Table 3.** Appearance and Characteristics of the Samples

Physical Appearance of the Samples	Details
	<ul style="list-style-type: none"> <li>• Sample mass: 1kg</li> <li>• Material: 100% soil</li> </ul>
	<ul style="list-style-type: none"> <li>• Sample mass: 1kg</li> <li>• Material: 100% sand</li> </ul>
	<ul style="list-style-type: none"> <li>• Sample mass: 1kg</li> <li>• Material: 50% soil + 50% sand</li> </ul>

The type of soil sample used was the first sample of soil, the second sample of sand, the third sample was a mixture of soil (50%) and sand (50%). The mass of the sample used was uniformly 1kg for each sample at the time of the test.

**Table 4.** Appearance and Characteristics of Components on The Inclined Plane

Physical Appearance of Incline Plane Components	Details
	<ul style="list-style-type: none"> <li>• Pendulum mass: 0,1kg</li> <li>• Pendulum material: brass</li> </ul>

Physical Appearance of Incline Plane Components	Details
	<ul style="list-style-type: none"> <li>Inclined plane with the addition of a certain spaced and uniformly spaced grid.</li> <li>Incline degree: 44,3°</li> </ul>
	<ul style="list-style-type: none"> <li>Inclined plane with distance between grids = 4cm and made of plastic material.</li> <li>Grid to hold soil samples from falling/landslides easily.</li> </ul>
	<ul style="list-style-type: none"> <li>Sensor equipped with a handle/bracket with a mass of ±55gr</li> <li>Length of the sensor connecting rope and pendulum = ± 97cm</li> </ul>

*Soil Samples for Prototype System Testing*

Soil movement data ranging from 3 to 5cm were obtained from sensor as seen in Table 5. When the frequency is 5Hz and the duration is between 40 and 50 seconds, the largest movement occurs which is 5cm.

**Table 5.** Test Result Data of Prototype System Using a Soil Sample with a disturbance Frequency of 1Hz -5Hz and a Maximum Duration of 50 Seconds

Duration	1 Hz	2Hz	3Hz	4Hz	5Hz
5 secs	3	3	3	3	3
10 secs	3	3	3	3	3
15 secs	3	3	3	3	3
20 secs	3	3	3	3	3
25 secs	3	3	3	3	4
30 secs	3	3	3	3	4
35 secs	3	3	4	4	4
40 secs	3	4	4	4	5
45 secs	3	4	4	4	5
50 secs	3	4	4	4	5

*Sand Samples for Prototype System Testing*

Sand movement data ranging from 3cm to 11cm were obtained from sensor as seen in table 6. The biggest movement of 11cm occurs three times when the frequency of 3Hz duration is 50 seconds, frequency 4Hz duration is 50 seconds and frequency 5Hz duration is 50 seconds.

**Table 6:** Test Result Data of Prototype System Using a Sand Sample with a disturbance Frequency of 1Hz -5Hz and a Maximum Duration of 50 Seconds

Duration	1 Hz	2Hz	3Hz	4Hz	5Hz
5 secs	3	3	3	3	3
10 secs	4	4	4	4	4
15 secs	5	5	5	5	5
20 secs	6	6	6	6	6
25 secs	7	7	7	7	7
30 secs	8	8	8	8	8
35 secs	9	9	9	9	9
40 secs	9	9	9	9	10
45 secs	9	9	10	10	10
50 secs	10	10	11	11	11

*Soil Sand mixture Samples for Prototype System Testing*





Soil Sand-mixed samples movement data ranging from 3cm to 8cm were obtained from sensor as seen in table 7. The biggest movement of 8cm occurs when the frequency of 5Hz duration is 50 seconds.

**Table 7.** Test Result Data of Prototype System Using a Soil Sand-mixture Sample with a disturbance Frequency of 1Hz -5Hz and a Maximum Duration of 50 Seconds

Duration	1 Hz	2Hz	3Hz	4Hz	5Hz
5 secs	3	3	3	3	3
10 secs	3	3	3	3	3
15 secs	3	3	3	4	3
20 secs	4	4	4	4	4
25 secs	5	5	5	5	5
30 secs	5	5	5	5	5
35 secs	6	6	6	6	6
40 secs	6	6	6	6	6
45 secs	6	7	7	7	7
50 secs	6	7	7	7	8

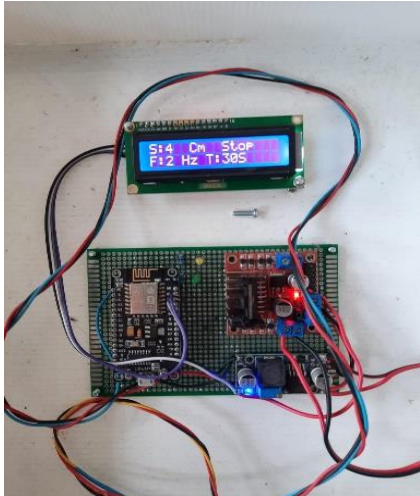
HMI displays during the Test

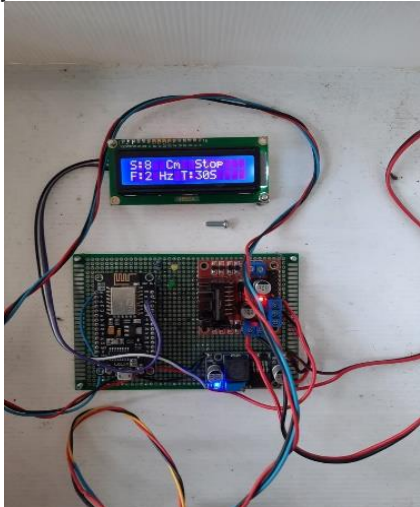
**Table 8.** Soil Movement Data Acquisition Proofs with Sensor Displayed on LCD and Blynk Application.

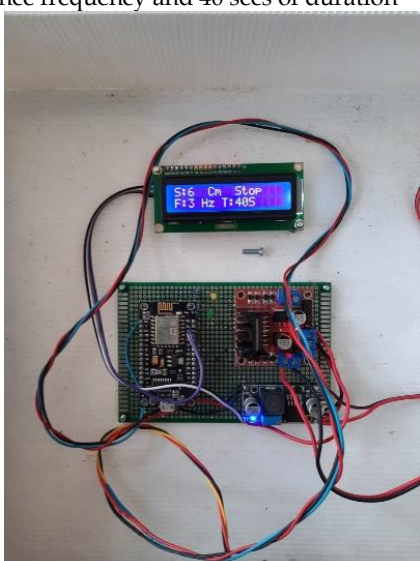
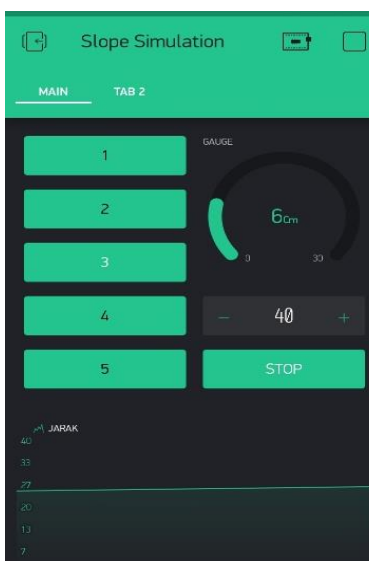
Testing Appearance	LCD Display	Blynk App Display
<p data-bbox="124 314 831 342">Soil sample, 2Hz of disturbance frequency and 30 secs of duration</p> 		
<p data-bbox="124 842 831 871">Sand sample, 2Hz of disturbance frequency and 30 secs of duration</p> 		
<p data-bbox="124 1381 979 1410">Soil sand mixture sample, 3Hz of disturbance frequency and 40 secs of duration</p> 		



Test data analysis with three different samples and varying frequency and duration, as follows:

Sample 1, Soil, the data obtained for soil movement of 3cm for a duration of 5 seconds to 50 seconds with the first disturbance frequency of 1Hz, the second frequency 2Hz has obtained the largest movement of 4cm for 45 seconds and 50 seconds. The third disturbance frequency of 3Hz obtained the largest movement of 4cm when the duration of 35 seconds, and 40 seconds and the fourth frequency of 4Hz obtained the largest movement shift is 4cm when the duration of 40 seconds.

Sample 2, Sand, the largest sand movement is 10 cm for a duration of 50 seconds with a frequency disturbance of 1Hz. Second, with disturbance frequency of 2Hz has the largest movement is 10cm for a duration of 50 seconds. Third, with the disturbance frequency of 3Hz has the largest movement being 11cm for a duration of 50 seconds. Then with the fourth frequency 4Hz has the largest movement is 11cm for a duration of 50 seconds.

Sample 3, Soil Sand Mixture with the disturbance frequency of 1Hz, the largest movement is 6 cm for a duration of 35 seconds. Second, with a disturbance frequency of 2Hz, the largest movement is 7 cm for 45 seconds. Third, with the frequency of 3Hz, the largest movement is 7cm when the duration is 45 seconds and 50 seconds. Fourth, with a frequency of 4Hz, the largest movement is 7cm when the duration is 50 seconds. Last, the frequency is 5Hz, the largest movement is 8cm when the duration is 50 seconds.

Sand has a greater potential for movement on an inclined plane when the disturbance frequency is 3Hz to 5Hz. When reaching the maximum duration of 50 seconds, there is a movement of 11cm.

## Conclusion

This prototype system is designed to provide information on soil movement on a 44.3° incline and types of soil that have a greater potential for move with ranging from 1Hz - 5Hz frequency and 5 - 50 seconds duration. With a soil sample, the largest movement data are 5 cm with a disturbance frequency of 5Hz and a duration of 40 seconds. Therefore, sand sample, the largest movement data is 11cm at a disturbance frequency of 3Hz and a duration of 50 seconds. Finally, the soil sand mixture has largest movement data at 8 cm at a frequency of 5Hz and a duration of 50 s. 3. The sand has a greater potential for shifting on an inclined plane with a disturbance frequency of 3Hz in a duration of 50 seconds

## Acknowledgements

Thank you to the Faculty of Industrial Technology, Jayabaya University for funding this research in

accordance with the contract number: 71.001/KONTRAK PENELITIAN/FTI-UJ/XII/2021

## References

- Adriansyah, A., & Hidyatama, O. (2016). Rancang Bangun Prototype Elevator Menggunakan Microcontroller Arduino ATmega 328P. *Jurnal Teknik Elektro*, 4(3), 100-112. <http://dx.doi.org/10.22441/jte.v4i3.753>
- Artha, O., Budi, R., & Rahmi, E. (2018). Sistem Peringatan Dini Bencana Longsor Menggunakan Sensor Accelerometer dan Sensor Kelembaban Tanah Berbasis Android. *Journal of Information Technology and Computer Engineering*, 2(2), 14-20. <https://doi.org/10.25077/jitce.2.02.64-70.2018>
- Handi, H., Hurryatul, F., & Gembong, E. S. (2019). Sistem Pemantauan Menggunakan Blynk dan Pengendalian Penyiraman Tanaman Jamur dengan Metode Logika Fuzzy. *Jurnal Pengembangan Teknologi Informasi dan Ilmu Komputer*, 3(4), 3258-3265. Retrieved from <https://j-ptiik.ub.ac.id/index.php/j-ptiik/article/view/4907>
- Heru Sri, N., Hasmana, S., Deliyanti, G., Firman, P., & Agus, K. (2019). Analisis Penyebab Kejadian dan Evaluasi Bencana Tanah Longsor di Desa Banaran, Kecamatan Pulung, Kabupaten Ponorogo, Provinsi Jawa Timur Tanggal 1 April 2017. *JURNAL ILMU LINGKUNGAN*, 17(2), 272-282. <https://doi.org/10.14710/jil.17.2.272-282>
- Meisya, B. B., Haris, E., & Taufik Anwar, S. (2018). THOR (Pendeteksi Tanah Longsor): Deteksi Bencana Tanah Longsor Menggunakan Sensor "Tasbih" Berbasis SMS Gateway. *Jurnal Edukasi Elektro*, 2(2), 87-91. <http://dx.doi.org/10.21831/jee.v2i2.22460>
- Naldi, A., & Wildian. (2018). Rancang Bangun Sistem Alarm Gempa Bumi Menggunakan Prinsip Gaya Pegas dan Penginderaan Medan Magnetik. *Jurnal Fisika Unand*, 7(4), 374-378. <https://doi.org/10.25077/jfu.7.4.374-378.2018>
- Naser Hossein, M., Mahsa, M., Julian, H., & Behnam, Z. (2020). Internet of Things (IoT) and the Energy Sector. *Energies*, 13(494), 1-27. <https://doi.org/10.3390/en13020494>
- Navila, Q. A. (2017). *Pengembangan Modul Pembelajaran Fisika Materi Getaran dan Gelombang, Bunyi dan Cahaya kelas VIII SMP/MTs Berbasis Unity of Sciences*. Semarang : Universitas Islam Negeri Walisongo.
- Nursuwars, F., Kurniati, N., & Hidayat, M. (2019). Accelerometer sebagai Pendeteksi Dini Pergerakan Tanah. *Jurnal Ilmiah Setrum*, 8(1), 9-17. <http://dx.doi.org/10.36055/setrum.v8i1.4110>
- Pratiwi, N.K.D., Dewa Made, W., & Widyadi, S. (2018). Rancang Bangun Sistem Peringatan Dini Bahaya Tanah Longsor dengan Sensor Hygrometer dan

- Piezoelectric. *E-Journal SPEKTRUM*, 5(2), 183-189.  
<https://doi.org/10.24843/SPEKTRUM.2018.v05.i02.p23>
- Superadmin Data. (2022, February 18). *Kejadian Bencana Tahun 2021*. Retrieved from Badan Nasional Penanggulangan Bencana: Retrieved from <https://bnpb.go.id/infografis/kejadian-bencana-tahun-2021>
- Wang, F., Xu, P., Wang, C., Wang, N., & Jiang, N. (2017). Application of a GIS Based Slope Unit Method for Landslide Susceptibility Mapping along the Longzi River, Southeastern Tibetan Plateau, China. *ISPRS International Journal of Geo-Information*, 6(6), 172. <https://doi.org/10.3390/ijgi6060172>