

Planning the decarbonisation of energy systems: the importance of applying time series clustering to long-term models

*Original*

Planning the decarbonisation of energy systems: the importance of applying time series clustering to long-term models / Novo, Riccardo; Marocco, Paolo; Giorgi, Giuseppe; Lanzini, Andrea; Santarelli, Massimo; Mattiazzo, Giuliana. - In: ENERGY CONVERSION AND MANAGEMENT. X. - ISSN 2590-1745. - ELETTRONICO. - 15:(2022), p. 100274. [10.1016/j.ecmx.2022.100274]

*Availability:*

This version is available at: 11583/2970636 since: 2022-08-12T17:52:15Z

*Publisher:*

Elsevier

*Published*

DOI:10.1016/j.ecmx.2022.100274

*Terms of use:*

openAccess

This article is made available under terms and conditions as specified in the corresponding bibliographic description in the repository

*Publisher copyright*

(Article begins on next page)

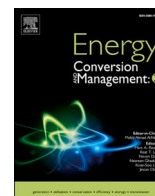

## Planning the decarbonisation of energy systems: The importance of applying time series clustering to long-term models

Riccardo Novo<sup>a,c,d,\*</sup>, Paolo Marocco<sup>b</sup>, Giuseppe Giorgi<sup>a,c</sup>, Andrea Lanzini<sup>b,d</sup>,  
Massimo Santarelli<sup>b</sup>, Giuliana Mattiazzo<sup>a,c,d</sup>

<sup>a</sup> Dipartimento di Ingegneria Meccanica e Aerospaziale, Politecnico di Torino, 10129 Torino, Italy

<sup>b</sup> Dipartimento Energia "Galileo Ferraris", Politecnico di Torino, 10129 Torino, Italy

<sup>c</sup> MOREnergy Lab, Politecnico di Torino, 10129 Torino, Italy

<sup>d</sup> Energy Center Lab, Politecnico di Torino, 10129 Torino, Italy

### ARTICLE INFO

#### Keywords:

Energy systems  
Renewable energy  
Mixed integer linear programming  
Energy modelling  
Time series clustering

### ABSTRACT

The study of future energy scenarios with high shares of variable renewable energy sources (VRES) requires an accurate representation of VRES variability and storage capacity. However, long-term optimal expansion models, which are typically used to prescribe the evolution of energy systems, make use of coarse time series to limit computational effort. This weakness can entail an incorrect sizing of VRES plants and storage facilities. In this work, a novel method is proposed to mitigate the current limitations and enable accurate long-term planning of high-VRES decarbonisation pathways. Clustering methods are applied to time series, preserving the possibility of having inter-day and intra-day energy storage. To this end, the temporal framework of an open-source energy system model, OSeMOSYS, is modified to allow the implementation of interconnected, clustered representative days. Traditional and novel approaches are compared and benchmarked for a reference case study, i.e., a remote island. The results show that time series clustering can significantly improve the evaluation of the overall system cost, leading to a relative error of  $-5\%$  (novel approach) instead of  $-35\%$  (traditional approach) when 24 representative days are considered. Similarly, the new approach improves the sizing of VRES and storage facilities. The new technique is found to require three orders of magnitude less computation time than the traditional technique to achieve a comparable level of accuracy.

### 1. Introduction

The Glasgow Climate Pact (2019) stressed the need for a worldwide carbon-neutral economy by the middle of this century [1]. Energy system decarbonisation and renewable energy source (RES) exploitation are the cornerstones for the achievement of such target [2]. Pathways that should be followed to achieve global energy sustainability have been identified, and they should include the power, heat, transport and desalination sectors [3]. In addition, it has been demonstrated that decarbonisation can lead to significant cross-cutting benefits: primarily the reduction of air pollution-related mortality, the stabilisation of energy supply costs, and the creation of permanent new jobs [4].

In this context, a considerable deployment of variable renewable energy sources (VRES) can be expected, with wind and solar photovoltaic (PV) power sources representing around 50 % of the global power mix forecast for 2050 [5]. Storage and power-to-X systems will thus play

a key support function to ensure a secure energy supply and cross-sectorial integration [6]. Consequently, long-term planning (considering one or several decades) of the evolution of energy systems is required to identify the most suitable decarbonisation pathway and ensure that carbon neutrality is accomplished in a cost-effective and reliable way [7].

Long-term optimal expansion planning is often addressed by means of linear programming (LP) or mixed-integer linear programming (MILP) techniques. Some of the best-known tools are the well-established MESSAGE [8] and TIMES [9] modeling frameworks, or the more recent open-source Balmorel [10], TEMOA [11], Calliope [12] and OSeMOSYS [13] tools. Increasing attention has recently been paid to high-RES penetration scenarios from a long-term perspective. Kato and Kurosawa [14] explored ambitious decarbonisation scenarios in Japan, considering a VRES penetration of up to 65 %, through a TIMES-based model. Xiufeng et al. [15] described a possible 100 % renewable energy scenario in Ireland by 2050, with over 85 % of the electricity

\* Corresponding author at: Dipartimento di Ingegneria Meccanica e Aerospaziale, Politecnico di Torino, 10129 Torino, Italy.

E-mail address: [riccardo.novo@polito.it](mailto:riccardo.novo@polito.it) (R. Novo).

### Nomenclature

BATT	batteries
conf	configuration
DSL	diesel
DSL_PP	diesel power plant
ELC	electricity
IMP_DSL	diesel import
LP	linear programming
MILP	mixed integer linear programming
NEW	novel method
OF	objective function
OSeMOSYS	Open Source Energy Modelling System
PV	photovoltaic
RDs	representative days
RES	renewable energy sources
SOC	state-of-charge
TRAD	traditional method
VRES	variable renewable energy sources
WT	wind turbines

coming from solar, wind and ocean energy sources. Moreover, through a Swiss TIMES model, Panos et al. [14] studied a 2050 net-zero emission scenario, with a VRES contribution in the power mix of over 40 %. Tróndheim et al. [16] used a Balmorel model to develop energy scenarios for 2030 for the Faroe Islands, with a power mix of wind and solar energy of up to 85 %. Laha and Chakraborty [17] implemented a Calliope-based Indian multi-regional model to examine RES shares of up to 75 %, supported by batteries, hydrogen storage and pumped hydro power. Rady et al. [18] used an OSeMOSYS model to analyse the evolution of the optimal power generation mix in Egypt under different constraints on the availability of natural gas, and obtained a feasible VRES penetration of around 65 % by 2040. English et al. [19], in order to highlight the importance of inter-regional coordination when dealing with large shares of VRES, studied a ~ 95 % RES share (56 % wind) in the power mix of British Columbia and Alberta by 2060. Therefore, it can be seen that LP/MILP-based models have been widely used to study future scenarios that consider significant contributions from VRES.

The correct sizing of storage systems, when dealing with high-RES penetration, is crucial: their price can affect the final cost of the energy supply to a great extent, and the optimal configurations to be pursued. Moreover, storage facilities are needed to guarantee the security of the supply. McPherson and Tahseen [20] developed a production cost dispatch model for the Ontario region of Canada. In the absence of adequate utility-scale storage, they remarked that VRES curtailment could reach 24 % when the total share of wind and solar energy amounted to 80 %. This value would be 37 % when the wind share alone amounted to 80 %. Dowling et al. [7] studied the U.S. energy system. They found that the introduction of long-duration (>10 h) storage (e.g., power-to-power) can reduce the cost of the system by ~ 15 % in a 100 % VRES penetration scenario, compared to a configuration with only power-intensive storage. Colbertaldo et al. [21] studied the California power system and reported that a 100 % VRES supply was feasible. They observed that large energy-intensive storage – with a power capacity of half of the RES installed capacity - is needed to ensure acceptable solar and wind power plant curtailment levels. Cebulla et al. [22] conducted a review of the existing studies on electricity storage in the U.S., Europe and Germany. They found that, as the VRES shares grow, the demand for storage increases linearly in terms of power capacity, but exponentially in terms of energy capacity.

The accurate description of VRES variability is a key challenge in energy system models. In the literature review by Lopion et al. [23], an increasing trend towards a higher temporal resolution, to better

represent the variability of renewables, was shown for energy system modelling. Rinkjøb et al. [24] found that coarse time-steps in energy system models can lead to unfavourable investments, overestimation of the VRES and underestimation of the costs. Multi-year LP/MILP energy modelling frameworks require the use of sample periods to limit the computational burden [25]. Such frameworks are usually characterised by a rigid representation of time series, which are based on typical periods (time slices) obtained by considering the recurrence of seasons (e.g., the summer season), day types (e.g., weekdays) and daily brackets (e.g., mornings). However, the resulting time framework can prevent a detailed modelling of VRES and storage technologies [26], and thus the identification of feasible configurations, and this can lead to an underestimation of the necessary investment [27]. This weakness becomes more evident as the time series gain importance in the system modelling, which takes place when the required share of VRES increases [28]. In such a context, Wyrwa et al. [29] suggested combining long- and short-term energy system models to validate the results of expansion planning with an hourly dispatch model, and eventually acting on the reserve capacity options with a feedback mechanism. Pavičević et al. [30] studied the benefits of sector coupling for future European energy systems by soft-linking a TIMES-based model with a unit commitment and optimal dispatch model. However, the solutions proposed so far require different modelling tools and, thus, the need for further modelling and greater computational efforts.

Time series clustering has also been shown to improve the accuracy of the modelling of energy storage systems and VRES variability. Gabrielli et al. [31] proposed an MILP formulation, based on the clustering and subsequent coupling of representative days, to improve the modelling of high-capacity storage components. This methodology allowed them to simulate a year-long time horizon with an hourly resolution, while reducing the number of binary variables, and thus the complexity of the optimisation problem. Kotzur et al. [32] derived a two-layer state methodology by linking a sequence of clustered representative days over the year, and showed benefits when dealing with seasonal storage. Welder et al. [33] then applied this concept and carried out a spatiotemporal optimisation of energy systems for power-to-hydrogen applications, considering a 1-year time horizon. Furthermore, Limpens et al. [34] compared different clustering methods for the EnergyScope TD (Typical Days) framework, but their model considers a single target year. Nahmmacher et al. [35], on a long-term modelling scale, applied a hierarchical clustering algorithm to the LIMES (Long-term Investment Model for the Electricity Sector)-EU [36] model; however, their approach does not enable the modelling of storage for consecutive clustered days or groups of days.

From this summary, it can be seen that time series clustering is not common in multi-year capacity expansion models. Moreover, to the best of the authors' knowledge, no studies have been conducted that discuss time series clustering while considering inter-period storage in long-term energy system models.

This work seeks to address this lack of long-term energy modelling frameworks for the representation of VRES variability and the simulation of storage technologies. Interconnected clustered representative days (RDs) have here been implemented in an existing open-source modelling tool. The novel methodology is then applied to a reference case study that includes energy storage technologies with high-RES penetration levels. The obtained results are then compared with those obtained from a traditional method to show the advantages that may be derived from the implementation of interconnected clustered RDs, in terms of identifying the best decarbonisation pathway.

This work is structured as follows: the proposed changes to the temporal framework of long-term energy models are described in Section 2; the model validation strategy, which consists of a reference case study and a sensitivity analysis, is presented in Section 3; the obtained results are shown and discussed in Section 4 in relation to the existing literature; finally, conclusions are drawn and future developments are identified in Section 5.

## 2. Methodology

This section introduces the key features of OSeMOSYS, i.e., the energy system modelling tool that has here been used, focusing on its time representation. Then, the novel approach, which consists of the retrofitting of OSeMOSYS, is introduced.

### 2.1. Long-term modelling approach

OSeMOSYS is an open-source and transparent tool that was developed and is maintained by a professional scientific community [37]. The key elements of OSeMOSYS – and which are common to all LP/MILP problems – are the following: sets, which are used to define the physical structure of the model; parameters, which represent the inputs of the model and which can be used to build different scenarios; variables, i.e., the outputs of the model.

The energy system structure of OSeMOSYS is based on *regions* (bounded areas in which the supply–demand balance is ensured), *fuels* (i.e., energy vectors), *technologies* (which transform, extract, import or export energy vectors), and *storages* (which allow fuels to be accumulated over different time periods). The objective function (*OF*) is the minimisation of the net present cost of the energy system [38]:

$$OF = \min \left( \sum_r \sum_y \left( \sum_t TotalDiscountedCostByTechnology[r, t, y] + \sum_s TotalDiscountedStorageCost[r, s, y] \right) \right) \quad (1)$$

where  $TotalDiscountedCostByTechnology[r, t, y]$  is the total discounted cost of each *technology* ( $t$ ) in each *region* ( $r$ ) and *year* ( $y$ ), and  $TotalDiscountedStorageCost[r, s, y]$  is the total discounted cost of each *storage* ( $s$ ) in each *region* ( $r$ ) and *year* ( $y$ ). The main parameters used to calculate discounted costs are the capital, variable, and fixed costs.

The key decision variables in OSeMOSYS are the following: *technology* and *storage* installed capacity for each year (i.e., the system configuration evolves year by year along with the considered time framework); the rate of activity of each *technology*; and the rate of charge/discharge of each *storage* for each typical time interval. The main boundary conditions are as follows: the supply of energy or of energy services to meet the specified demands and their profiles over the year; the production capability of each *technology*, which in part depends on the RES availability over time; the limitations imposed by the modeller, in terms of minimum and maximum capacity; and the minimum and maximum activity of each *technology* and *storage* system.

From the time representation point of view, OSeMOSYS uses five sets that are shown in Table 1. The sequence of *seasons*, *daytypes* and *dailytimebrackets* is displayed in Fig. 1: each year is made up of  $m$  seasons ( $ls$ );

**Table 1**  
List of the time-related sets in OSeMOSYS and their description [38].

SET	Description
Year ( $y$ )	All the years that have to be considered in the model.
Season ( $ls$ )	Seasons (e.g., winter, spring, summer, autumn → <i>season</i> : [1,4]) that are accounted for in the model.
Daytype ( $ld$ )	Day types (e.g., weekdays, weekend → <i>daytype</i> : [1,2]) that are accounted for in the model.
Dailytimebracket ( $lh$ )	Sections of the day (e.g., morning, afternoon, night → <i>dailytimebracket</i> : [1,3]) that are accounted for in the model.
Timeslice ( $l$ )	Typical time intervals that have to be used in the model. Their number is equal to the product of the number of <i>seasons</i> , <i>daytypes</i> and <i>dailytimebrackets</i> (e.g., with the above examples → <i>timeslice</i> : [1,24]).

$n$  *daytypes* ( $ld$ ) occur recursively in each season; and  $p$  subsequent *dailytimebrackets* ( $lh$ ) occur in each *daytype*. The time-related parameters (e.g., power load profile, VRES capacity factors) are obtained by averaging original time series according to the recurrence of *seasons*, *daytypes* and *dailytimebrackets* over the year. This approach was developed to follow energy consumption patterns, but may be inadequate when other time series (e.g., VRES) are also considered. The use of *timeslices* – which are typical time intervals identified by a *season*, a *daytype* and a *dailytimebracket* – reduces the complexity of the problem and allows multi-year optimal planning problems to be solved.

The allocation of each *timeslice* to a *season*, a *daytype* and a *dailytimebracket* is needed to obtain a timeline, which is essential to ensure the correct operation of *storage* systems. Although the energy balance is made at the *timeslice* level, the state-of-charge (SOC) of storage systems is only verified at certain moments: as a matter of fact, extreme SOC values of *storage* systems can only occur during the first and last week of a specific *season*, and during the first and last occurrence of a particular *daytype* [39].

In this work, the authors have made use of the Python-Pyomo implementation of OSeMOSYS [40]. The next section provides details about the changes made to the modelling framework.

### 2.2. Novel time framework

The novel framework introduced herein consists of a clustering method, which is used for the clustering of the original time series, and a revised long-term energy modelling approach. A schematic of the overall methodology is depicted in Fig. 2. In contrast to the traditional OSeMOSYS approach where a sequential averaging of time series is carried out, in the novel approach representative days are defined through a clustering process based on a set of attributes, namely the time

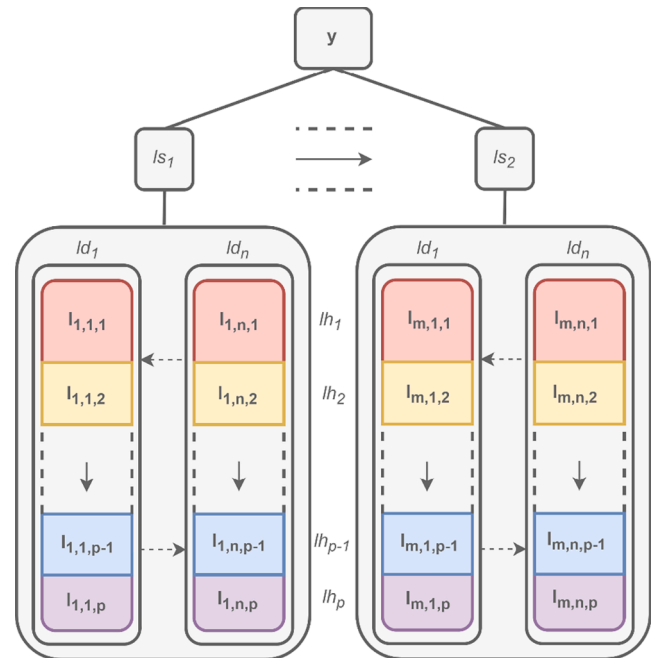

**Fig. 1.** Temporal sequence of *timeslices* ( $l$ ) obtained from the combination of *seasons* ( $ls$ ), *daytypes* ( $ld$ ) and *dailytimebrackets* ( $lh$ ).

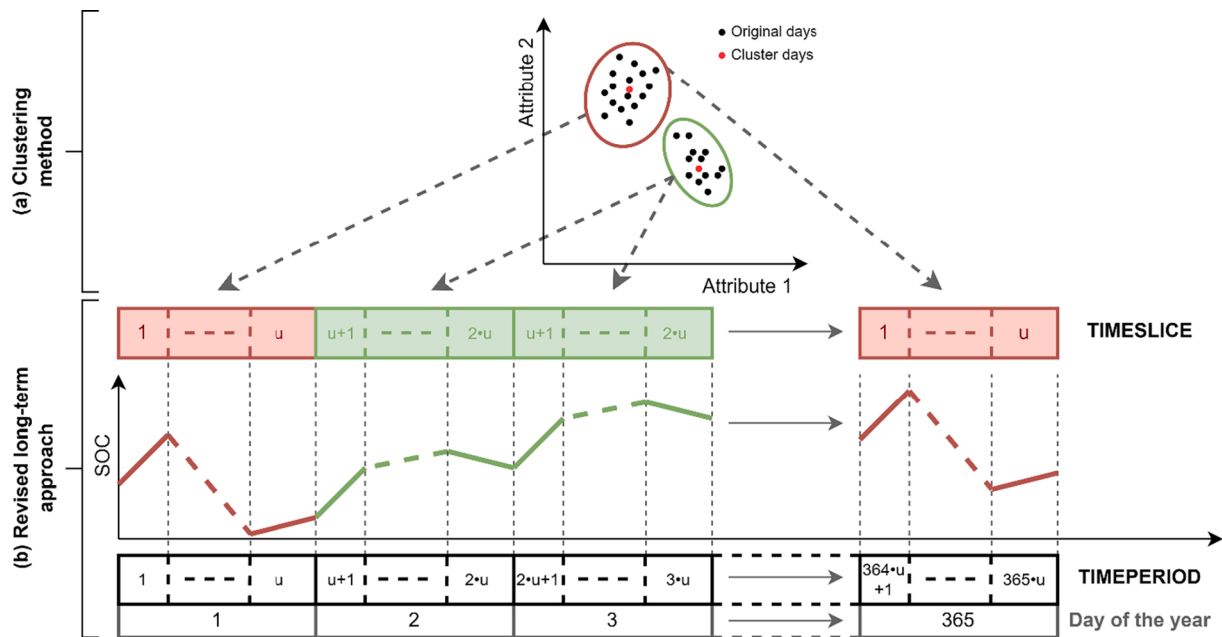

Fig. 2. The implemented methodology consists of two parts: (a) a clustering method, which is applied to the original time series in order to generate inputs for the long-term energy model (the image represents a basic case with two attributes and two clusters; each representative day consists of  $u$  timeslices); (b) a revised long-term approach, based on OSeMOSYS, in which *timeslices* are decoupled from *seasons* and *daytypes*; to do so, the new *timeperiod* set is introduced, while the *season*, *daytype* and *dailytimebracket* sets are no longer needed.

series of specific *fuel* demands and of the productivity from renewable technologies.

### 2.2.1. Clustering method

Clustering has here been used for the identification of the representative days. The goal is to combine all the days of the year into a predetermined number of groups (representative days) so that the group members are as similar as possible.

Increasing attention has recently been paid to clustering approaches such as k-means [31], k-medoids [41] and hierarchical clustering [35]. The grouping of time series is generally based on a distance measure of the attributes between each group member [42]. In this work, the k-means technique was employed, because of its proven effectiveness when applied to energy systems [31]. K-means clustering is a partitioning method that creates clusters by minimising the squared error between the empirical mean of a cluster and all the candidates in the cluster. The main characteristic of this technique is that the total value of the original time series is preserved for each attribute since the representative days are computed as the mean profile of the cluster they represent. Each representative day consists of  $u$  time intervals, as also depicted in Fig. 2.

The present work uses VRES (solar PV and wind) capacity factors and electrical load profiles as attributes for the clustering process. In the "Results and discussion" Section, the number of clusters (i.e., number of representative days) was varied by performing a sensitivity analysis to determine when an accurate approximation of the full-scale solution (i.e., 365 representative days) is achieved.

Table 2

List of the time-related sets for the revised OSeMOSYS.

SET	Description
Year ( $y$ )	All the years that have to be considered in the model.
Timeslice ( $l$ )	Typical time intervals obtained by means of the clustering method (e.g., 5 representative day clusters, each day with 24 time intervals $\rightarrow$ <i>timeslice</i> : [1,120]).
Timeperiod ( $tp$ )	The chronological sequence of time intervals over the year (e.g., hourly time series $\rightarrow$ <i>timeperiods</i> : [1,8760]).

### 2.2.2. Revised long-term approach

The modifications to the temporal framework of the OSeMOSYS tool are reported hereafter. The OSeMOSYS framework was revised to implement clustered interconnected representative days, therefore maintaining their chronological order. Such an approach is aimed at enhancing the representation of VRES variability. The preservation of the RDs chronological order is also essential to improve the modelling of high-capacity energy storage systems [31].

The new time-related sets are presented in Table 2. The *year* and *timeslice* sets appear as before. However, the latter is no longer related to the *season*, *daytype* or *dailytimebracket* sets, which have been deleted. Instead, the *timeperiod* set, which represents the chronological sequence of time intervals over the year, has been added. Fig. 2 (bottom) shows the univocal, but not bijective, relationship between *timeperiods* and *timeslices*: one *timeslice* is assigned to each *timeperiod*, but each *timeslice* occurs as many times as the number of days associated to its RDs cluster. The new *timeperiod* set is needed to calculate the SOC of storage systems after each occurrence of each *timeslice*. The SOC variation is unique for each *timeslice*, i.e., the energy balance in the storage, and thus its SOC variation, is always the same when a certain *timeslice* occurs over the year. Nevertheless, as displayed in Fig. 2, the initial SOC of a *timeperiod*  $tp$  is equal to sum of the initial SOC of the previous *timeperiod*  $tp-1$  and the SOC variation in the *timeslice* associated to the *timeperiod*  $tp-1$ , as also reported in Eq. (4). Each *timeperiod* is thus interconnected with the subsequent *timeperiod* for an accurate modelling of the storage facilities.

The lists of the time-related parameters and storage variables in the

Table 3

List of the time-related parameters for the revised version of OSeMOSYS.

Parameter	Description
<i>TimeSliceSplit</i> [ $l$ ]	The length of one <i>timeslice</i> as a fraction of the whole year (e.g., 6 h <i>timeslice</i> $\rightarrow$ <i>TimeSliceSplit</i> = $6/(24 \cdot 365)$ ).
<i>Conversiontp</i> [ $tp,l$ ]	A binary parameter that associates each <i>timeperiod</i> to a specific <i>timeslice</i> .
<i>YearSplit</i> [ $l$ ]	The overall duration of a modelled <i>timeslice</i> in a year (e.g., 6 h <i>timeslice</i> that occurs 100 times a year $\rightarrow$ <i>YearSplit</i> = $6 \cdot 100 / (24 \cdot 365)$ ).

**Table 4**  
List of the time-related storage variables for the revised version of OSeMOSYS.

Variable	Description
$NetChargeWithinTimeSlice[r,s,l,y]$	Absolute variation in the level of a stored commodity for a certain <i>timeslice</i> .
$StorageLevelTimePeriodStart[r,s,tp,y]$	The absolute level of a stored commodity at the start of a <i>timeperiod</i> .
$NetChargeWithinYear[r,s,y]$	The absolute variation in the level of a stored commodity for a certain <i>year</i> .
$StorageLevelYearFinish[r,s,y]$	The absolute level of a stored commodity at the end of a <i>year</i> .
$StorageLevelYearStart[r,s,y]$	The absolute level of a stored commodity at the start of a <i>year</i> .

revised OSeMOSYS version are presented in Table 3 and Table 4, respectively. A key role is given to  $Conversiontpl$ , a new binary parameter that specifies the *timeslice-timeperiod* association mentioned above: it is 1 if the *timeperiod* is associated to that *timeslice*, 0 otherwise.

The  $NetChargeWithinTimeSlice$  variable (see Table 4) is calculated as:

$$\begin{aligned} NetChargeWithinTimeSlice[r,s,l,y] &= (RateOfStorageCharge[r,s,l,y] - RateOfStorageDischarge[r,s,l,y]) \\ &\quad *TimeSliceSplit[l] \end{aligned} \quad (2)$$

where  $RateOfStorageCharge$  and  $RateOfStorageDischarge$  are, respectively, the commodity that would be charged to or discharged from storage facility  $s$  in one *timeslice*, if it lasted a whole *year* [38].

The  $StorageLevelTimePeriodStart$ , for the first *timeperiod* of the year, is expressed as:

$$StorageLevelTimePeriodStart[r,s,tp,y] = StorageLevelYearStart[r,s,y] \quad (3)$$

For all the other *timeperiods*, the expression becomes:

$$StorageLevelTimePeriodStart[r,s,tp,y] = StorageLevelTimePeriodStart[r,s,tp-1,y] + \sum_l^{TIMESLICE} NetChargeWithinTimeSlice[r,s,l,y] * Conversiontpl[tp-1,l] \quad (4)$$

Furthermore, in each *timeperiod*, it should be:

$$StorageLevelTimePeriodStart[r,s,tp,y] \geq StorageLowerLimit[r,s,y] \quad (5)$$

and:

$$StorageLevelTimePeriodStart[r,s,tp,y] \leq StorageUpperLimit[r,s,y] \quad (6)$$

Eqs. (5) and (6) impose that the level of the stored commodity must always lie between a lower and an upper limit, which are calculated as functions of the invested energy capacity of the storage system and its maximum discharge depth.

All the revised storage equations can be consulted in the [supplementary material](#). Moreover, the full revised code has been made publicly available in [43].

### 3. Validation strategy

The validation of the novel method and its benchmarking, with respect to the traditional method, has been done by analysing the evolution of an isolated energy system from 2021 up to 2040, and by performing a sensitivity analysis on the number of *timeslices* used in the two approaches.

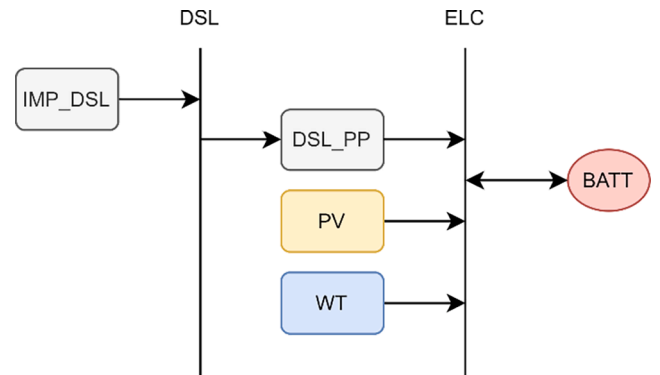

**Fig. 3.** Reference energy system used as a case study.

#### 3.1. Case study

The proposed methodology has been applied to a case study of Pantelleria, an island in the south of Italy that is not electrically connected to the mainland. The energy planning of isolated areas is necessary to decarbonise islands and remote areas, which are highly dependent on an external supply of fossil fuels [44]. Moreover, the methodologies and supporting schemes applied to isolated energy systems can also contribute to the local energy autonomy of interconnected areas, which is a scientific topic of relevant interest [45]. The Pantelleria energy system was selected because of the availability of a large number of data [46] and because of the presence of previous work developed by the authors concerning the decarbonisation process of the island [47].

The implemented reference energy system is shown in Fig. 3. It consists of two *fuels*, four *technologies* and one *storage* system. The *fuels* are diesel (DSL), which is used for power production, and electricity

(ELC), which has an associated final demand. The *technologies* are diesel import (IMP\_DSL), which supplies DSL; diesel power plant (DSL\_PP), which has DSL as the input and provides ELC; photovoltaic systems (PV) and wind turbines (WT), which supply ELC. Electrochemical batteries (BATT) are considered to store the ELC fuel.

The main techno-economic input parameters of the components were taken from [47]. The capital and variable costs of the *technologies* and *storages*, as well as their operational life are listed in Table 5. The adopted annual discount rate is 4%. Technology learning curves were used to account for any cost reductions over the model period. The cost of the storage systems was divided between the power and energy contributions, as proposed by Cole et al. [48]; this makes it possible to optimise the rated power and rated energy of the electrochemical storage separately. The BATT is characterised by a charging and discharging efficiency of 95%, while the DSL\_PP has a conversion efficiency of 39%.

As far as the renewables are concerned, annual PV productivity amounts to 1610 kWh/kW, with monthly peaks in summer; annual WT productivity amounts to 3780 kWh/kW, with monthly peaks in the January-March period, and troughs between June and September. Although the PV and BATT capacities were assumed to be continuous variables thanks to their modularity, the WT and DSL\_PP capacities were treated as integer variables by setting a unit capacity of 1 MW for both.

The annual ELC demand, which was around 27.3 GWh in 2021, was assumed to undergo a yearly increase of 1.5%, mainly related to the

**Table 5**  
Cost of the technologies and storage systems.

Technology / Storage	Source of the costs and elaboration	Capital cost (2021)	Capital cost (2030)	Capital cost (2040)	Variable cost (2021–2040)	Operational life
IMP_DSL	[47], value for the Pantelleria island	–	–	–	98 k€/MWh	–
DSL_PP	[49], assumed as constant over the model period	1024 k€/MW	1024 k€/MW	1024 k€/MW	–	20 y
PV	[50], values interpolated between 2020 and 2050	1022 k€/MW	523 k€/MW	405 k€/MW	–	25 y
WT	[51], values interpolated between 2020 and 2050	1300 k€/MW	957 k€/MW	845 k€/MW	–	25 y
BATT	[48]	500 k€/MW 154 k€/MWh	332 k€/MW 102 k€/MWh	304 k€/MW 89 k€/MWh	–	10 y

diffusion of electric vehicles [47]. The ELC demand profile shows very pronounced monthly peaks in summer, from 10.5 MW in 2021 up to 13.9 MW in 2040, due to the presence of a large number of tourists on the island.

A greenfield approach was implemented to ensure a transparent validation of the new technique. Therefore, no constraints on the total capacity and newly added capacity of the technologies and storage systems were considered. The identification of the best possible configuration is enabled from the first year onwards. The evolution of the foreseen system is related to the increase in the total energy demand and the learning curves of the technologies.

### 3.2. Sensitivity analysis and time representation

The novel method (NEW) and the traditional one (TRAD) have been compared by analysing the performance of the two techniques for an increasing number of representative days (RDs) per year. The following RDs were used: 6, 12, 24, 36, 48, 72, 144, 365, and the different configurations were called  $NEW_{RDs}/TRAD_{RDs}$ , depending on the method and the number of RDs. The validation of the results was performed over  $TRAD_{365}$ , which represents the “full-scale” configuration (i.e., traditional method with 365 RDs). In the TRAD method, the required number of RDs was obtained by varying the number of *seasons* and using a single *daytype* for each *season*. In the NEW method, the selected RD number was instead derived by applying the k-means clustering algorithm. It should be observed that the same number of RDs for TRAD and NEW also results in the same number of *timeslices*.

Furthermore, to ensure the handling and solvability of larger problems, 5 *timeslices* per day ( $u$  equal to 5) were considered for both TRAD and NEW, according to the daily subdivision shown in Table 6. This detail of the daily variation is in line with long-term energy expansion models from the literature [26,52,53].

An Intel® Xeon® CPU E3-1245 v5 @ 3.50 GHz CPU with 32 GB RAM was used for the calculations. The analysis and pre-processing of the input data were conducted via specifically developed Python codes. IBM ILOG® CPLEX® Optimization Studio software was used as the solver of the MILP models, with a relative MIP gap tolerance of 0.01 %.

## 4. Results and discussion

### 4.1. Full-scale model

The full-scale energy system optimisation, considering no constraints

**Table 6**  
Daily brackets for each representative day.

Daily brackets	Start hour	End hour
1	0	6
2	6	10
3	10	14
4	14	18
5	18	24

on the installed capacity, led to the outcomes presented in Table 7. The table shows the capacity of the considered technologies and storage systems, and the production of ELC from such technologies and their share, for the 2021, 2030 and 2040 reference years.

From the very beginning, the identified energy system is mainly based on VRES, with an overall penetration of solar and wind technologies of over 88 %. The optimal evolution of the system over the model period envisages a progressive increase in the PV capacity, while the size of the WT remains the same. Both the rated power and the rated energy of the BATT increase over the model period. Overall, the share of DSL\_PP progressively decreases to 3 % by 2040, due to the decrease in the cost of the VRES plants and storage system.

The obtained results are coherent with the outcomes of [47]: the high costs related to the supply of diesel on the remote Island of Pantelleria and, more generally, the high costs due to power generation with diesel make VRES considerably more convenient. Moreover, despite the need for power storage facilities and the high curtailment levels that may characterise such an island energy system [54], a very high penetration of VRES is economically preferable.

It is worth mentioning that the implemented model does not consider the congestions of networks and the grid stability. However, the expected impact on the results for TRAD and NEW would be the same, and the simplification does not affect the validation of the novel approach. Overall, grid-related issues would be better addressed through the use of operational power models [24].

### 4.2. Validation and benchmarking

The performance of the NEW and TRAD methods for different configurations (i.e., different number of RDs) has been compared considering the total system cost, the capacity of the VRES plants, the rated power and rated energy of the storage systems, as well as the computational burden necessary to solve the generated MILP problems.

The relative error of the total system cost (i.e., the objective function) with respect to that of the full-scale model is calculated, for each configuration, as:

$$\forall \text{ conf in } [TRAD_6, \dots, TRAD_{365}, NEW_6, \dots, NEW_{365}] : \quad (7)$$

$$Rel.err.^{\pm}_{OF.conf} = \frac{OF_{conf} - OF_{TRAD_{365}}}{OF_{TRAD_{365}}}$$

Positive values of  $Rel.err.^{\pm}_{OF.conf}$  suggest that the OF evaluation in *conf* is overestimated, while negative values indicate that it has been underestimated. The value of  $Rel.err.^{\pm}_{OF.conf}$  for the different configurations is represented in Fig. 4. First, it can be observed that, for the studied model, the cost of the total system is consistently underestimated when representative days are used instead of the full time series (with all 365 days). The OF estimation converges for both the TRAD and NEW approaches, when the RDs are increased. As expected, the two methods are equivalent when considering 365 days: this outcome represents the first evidence for the validation of NEW.

NEW always guarantees a lower error than TRAD when it is used to

**Table 7**

Capacity of the technology and storage systems and the production and share of different technologies for 2021, 2030 and 2040 for the TRAD<sub>365</sub> configuration (full-scale model).

Technology / Storage	2021			2030			2040		
	Capacity	Production	Share	Capacity	Production	Share	Capacity	Production	Share
DSL_PP	3.0 MW	3.15 GWh	11 %	3.0 MW	1.44 GWh	5 %	3.0 MW	1.12 GWh	3 %
PV	11.3 MW	15.4 GWh	55 %	19.4 MW	21.6 GWh	68 %	26.0 MW	26.8 GWh	72 %
WT	5.0 MW	9.3 GWh	33 %	5.0 MW	8.9 GWh	28 %	5.0 MW	9.3 GWh	25 %
BATT	4.1 MW	-	-	6.4 MW	-	-	7.9 MW	-	-
	24.8 MWh	-	-	40.1 MWh	-	-	53.0 MWh	-	-

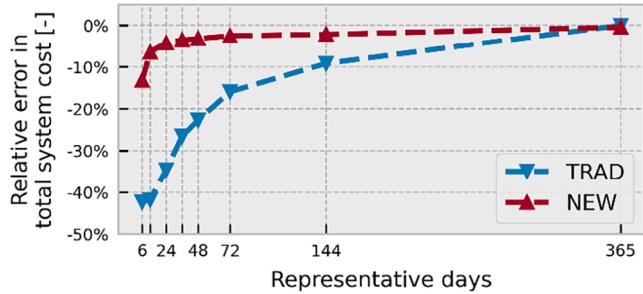

**Fig. 4.** Relative error in the total system cost for NEW and TRAD for different numbers of representative days.

estimate the total system cost considering the same number of representative days. TRAD demonstrates an inadequate performance for low RDs: TRAD<sub>6</sub> and TRAD<sub>12</sub> show underestimations of the costs of more than 40 %, thus suggesting that the optimal configurations that have been identified are unfeasible. On the other hand, NEW shows an absolute error that is always below 15 %, and lower than 5 % for 24 RDs and more.

The reasons behind the large differences in the OF estimation with NEW and TRAD can be clarified by looking at the values assumed for some of the critical decision variables in 2040 in Fig. 5. TRAD always largely underestimates the optimal PV capacity, by as much as -77 % in TRAD<sub>12</sub>, as shown in Fig. 5a. At the same time, NEW identifies a much more accurate PV capacity value in each configuration, with a maximum error of +7 % for NEW<sub>72</sub>. Similar behaviour can be observed for the WT capacity (Fig. 5b): TRAD largely overestimates the optimal WT capacity in all the configurations up to TRAD<sub>72</sub>, while NEW always ensures a maximum absolute error of ± 1 MW with the exception of NEW<sub>6</sub>.

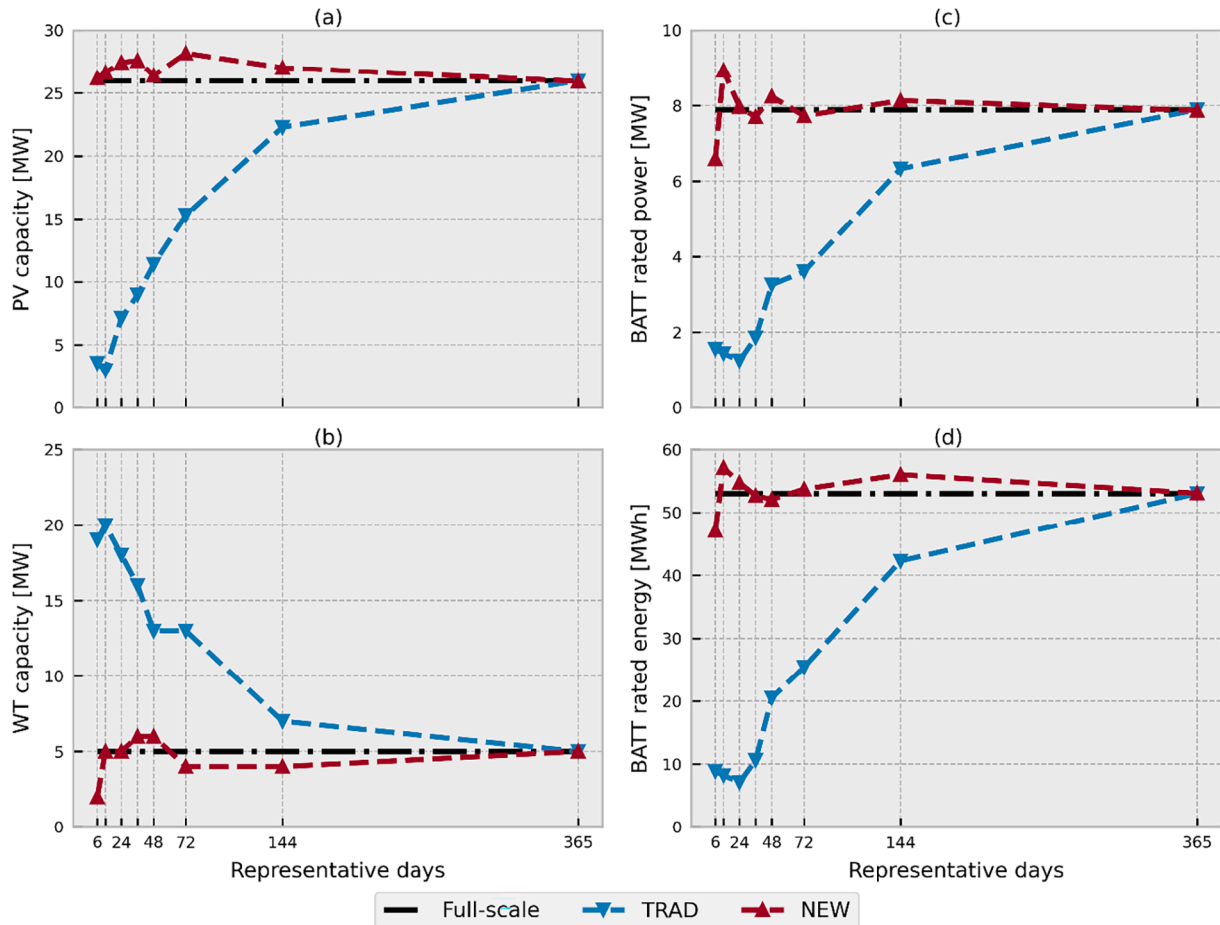

**Fig. 5.** (a) PV capacity, (b) WT capacity, (c) BATT rated power and (d) BATT rated energy in 2040 for the TRAD and NEW methods for an increasing number of representative days. In each chart, “Full-scale” represents the value obtained by TRAD for 365 representative days.



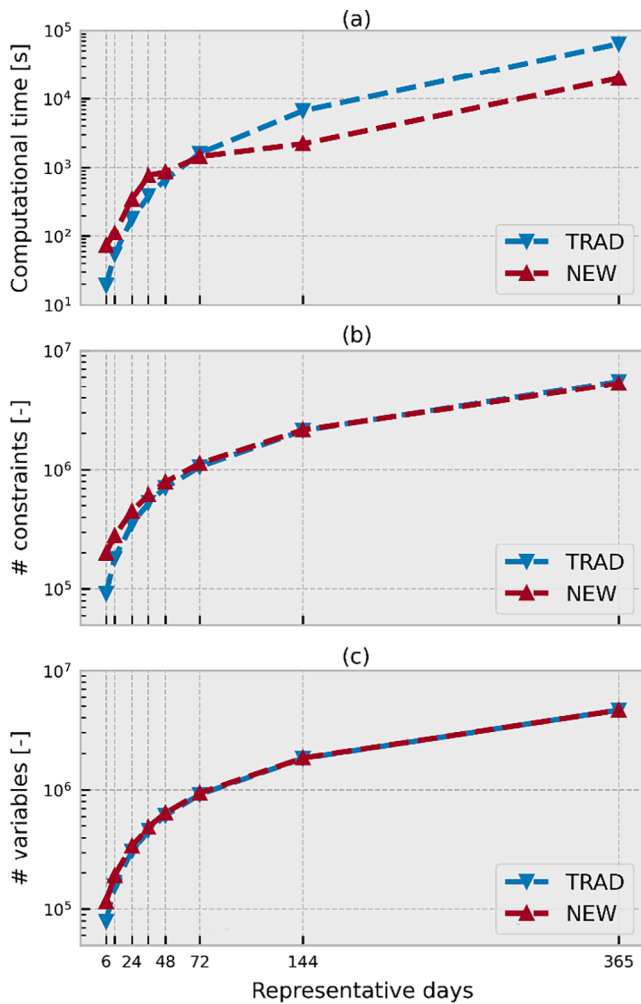

Fig. 6. Comparison of the computational time, the number of constraints and the number of variables for TRAD and NEW for an increasing number of representative days.

Finally, Fig. 5c and d represent the optimal rated power and rated energy of the BATT. Again, TRAD greatly underestimates the needed storage power and storage energy in all the configurations. NEW performs better, and accurately estimates both variables from 12 to 24 RDs onwards.

Similarly to the total system cost, the capacity variables progressively converge to the full-scale value for both techniques when the number of *timeslices* is increased. Moreover, the NEW and TRAD results always match for 365 RDs, thus confirming the validity of the new approach. Overall, TRAD always excessively promotes WT rather than PV for the case study considered in this work and underestimates the need for storage. On the other hand, NEW is able to point out the optimal configuration with a limited error, even for 12 RDs.

The demonstrated advantages derived from time series clustering and the NEW method should be evaluated in relation to the burden resulting from the introduction of the *timeperiod* set and the related storage equations. In this context, the results are illustrated in Fig. 6. Both techniques are characterised by a significant increase in the computational time when the number of RDs is increased (Fig. 6a), and several orders of magnitude of difference can be observed between the various configurations (i.e., different number of RDs). Moreover, NEW proves a slightly heavier computational burden than TRAD for a low number of RDs. Nevertheless, it has been demonstrated that fewer RDs are required to achieve good results when using NEW than when using TRAD. The saving in computational time, for the same accuracy of

results, amounts to about three orders of magnitude. The dimension of the studied MILP model is described in Fig. 6b and c, which show the number of constraints and the number of variables for the different configurations. The growth in the number of constraints and variables is similar for NEW and TRAD. It is worth noting that NEW<sub>6</sub> shows a higher number of constraints than TRAD<sub>6</sub>, but the difference decreases as the temporal detail of the problems increases.

The number of constraints introduced by the NEW approach does not vary as the number of RDs varies, because the *timeperiod* set is the same in all the configurations. On the other hand, a key reason for the greater steepness of the TRAD computational time curve than the NEW one may lie in the increasingly higher number of binary input parameters required to assign a certain *timeslice* to a *season* in TRAD. However, it should be noted that the number of constraints introduced by NEW increases when increasing the number of *storage* facilities that have to be modelled.

Moreover, the observed results reveal that the use of representative days rather than full-time series may be necessary to ensure a solution within an acceptable timeframe. The proposed case study has a relatively simple reference energy system, and a computational time of 6.4e4 s was required for the full-scale model (TRAD<sub>365</sub>) with our hardware. The use of several *regions*, the incorporation of many *timeslice*-dependent parameters and variables, and the use of a higher number of daily brackets could induce a much higher computational burden. Furthermore, it could even lead to difficulties in handling and solving the problem by means of the available hardware. In such a framework, using a limited number of representative days is fundamental, and the application of time series clustering methods has been shown to significantly help achieve reliable results.

The outcomes of TRAD and NEW with 24 RDs are compared in more detail in Fig. 7 with respect to the full-scale configuration (i.e., RDs equal to 365). The chart depicts the evolution of the technology installed capacity (Fig. 7a), the storage rated power (Fig. 7b), and the storage rated energy (Fig. 7c) for five different years. The overall installed capacity increases over the years in all the cases. However, the optimal configurations identified for TRAD<sub>24</sub> and NEW<sub>24</sub> are very different from each other. TRAD<sub>24</sub> does not include PV in 2021 or 2025, and it highly overestimates the WT capacity from the very beginning. Furthermore, TRAD<sub>24</sub> underestimates the size of the BATT throughout the whole model period. Such differences are responsible for the previously discussed poor estimation of the total system cost. On the other hand, NEW<sub>24</sub> identifies similar sizes to those of the full-scale configuration throughout the whole model period. The most significant error is a slight underestimation of the DSL\_PP installed capacity. Therefore, it has been demonstrated that making use of a time series clustering method in long-term energy models may be critical over the entire time horizon when planning large VRES shares in future energy systems.

The benefits derived from the new approach can significantly contribute to the enhancement of long-term energy planning. As pointed out by Ringkjøb et al. [24], several researchers have already combined capacity expansion modelling frameworks with unit commitment tools to reduce the underestimation of costs related to VRES. Nevertheless, the approach introduced in this work leads to a high level of accuracy of the sizing outcomes and does not require any increased modelling effort. An optimal VRES and storage portfolio is fundamental when dealing with ultrahigh carbon-free power systems [55]. Early sizing in fact makes it easier to implement energy planning policies, and effectively target public and private investments.

Finally, it should be recalled that the results discussed here have been obtained by making use of the hardware described in Section 3.2.

## 5. Conclusion

In this paper, a methodology has been developed to overcome one of the critical weaknesses of long-term energy models, i.e., issues that arise in estimating costs related to energy systems with high VRES

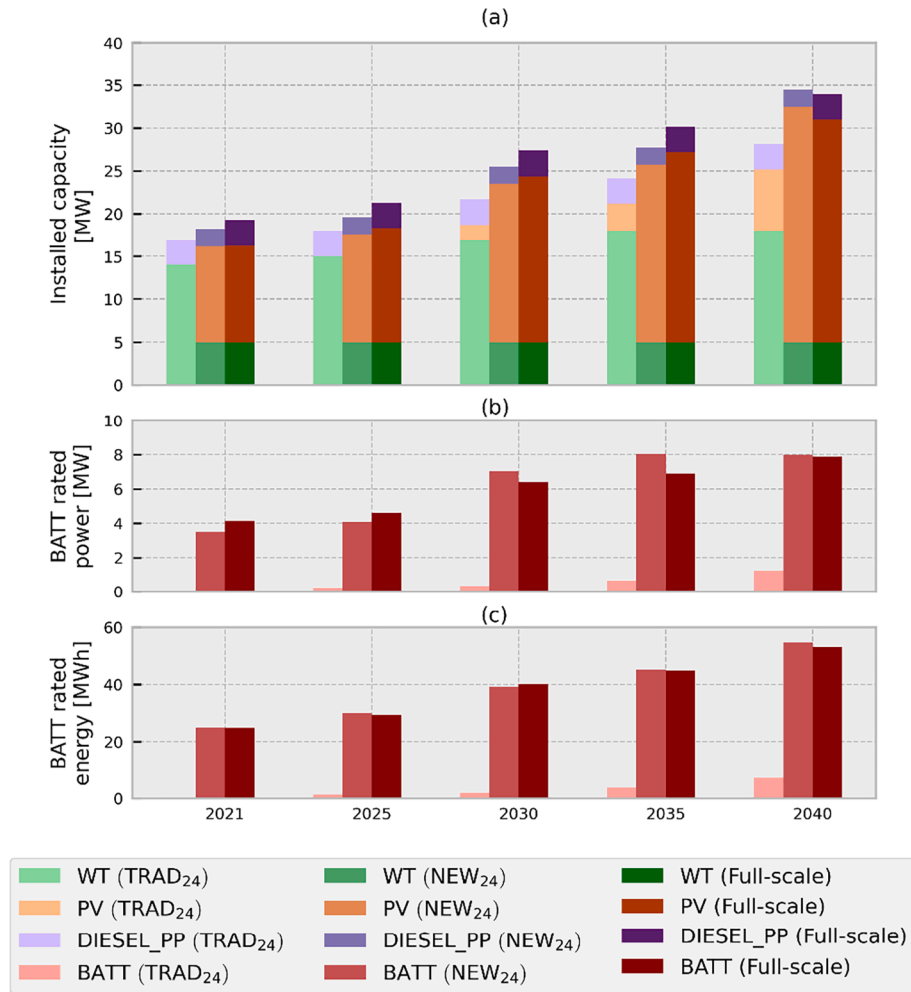

Fig. 7. Evolution of (a) the technology installed capacity, (b) the storage rated power and (c) the storage rated energy for different years for TRAD<sub>24</sub> and NEW<sub>24</sub>, and the full-scale configuration (TRAD<sub>365</sub>).

penetration. This weakness is mainly related to the approximation of original time series in average periods based on their appearance during the year in order to limit the computational burden. Here, clustering methods are proposed to achieve a more accurate representation of the load and VRES variability. Their implementation in energy systems with intra- and inter-day storage is enabled by the use of interconnected clustered RDs. The temporal framework of an open-source energy system model, OSeMOSYS, has been modified and applied to a remote island case study. The validity of the new approach has been evaluated by comparing its results with those of a full-scale model that considers all 365 days of the year. The performed work aims to provide a new technique for the retrofit of long-term energy modelling frameworks, in view of the new challenges arising from the decarbonisation of the energy supply.

An optimal VRES share between 89 % and 97 % was computed for the energy system under study. When considering 24 representative days, the traditional approach resulted in a relative error of  $-35\%$  of the total system cost, while the new method led to an underestimation of the objective function of less than 5 %. The traditional approach showed large inaccuracies in the optimal sizing of the energy system, even with 72 representative days. The new methodology, on the other hand, ensured a good sizing of VRES plants and storage starting from about 12–24 representative days. As for the computational effort of the two techniques, it was found that the new method guarantees the same accuracy of results as the traditional approach, but with a computational time of three orders of magnitude less. Therefore, it can be concluded

that its application is desirable when studying the long-term evolution of energy systems with large VRES shares.

Future works will focus on the application of the introduced method to complex energy systems, where the computational burden may become a major obstacle. The suitability of the novel approach to the analysis of the role of various storage means, e.g., hydrogen, will be explored. Finally, the effectiveness of different clustering algorithms will also be analysed to identify the most suitable ones for time series clustering.

#### CRediT authorship contribution statement

**Riccardo Novo:** Conceptualization, Methodology, Software, Validation, Formal analysis, Data curation, Writing – original draft, Writing – review & editing, Visualization. **Paolo Marocco:** Conceptualization, Methodology, Software, Validation, Formal analysis, Data curation, Writing – original draft, Writing – review & editing, Visualization. **Giuseppe Giorgi:** Writing – review & editing. **Andrea Lanzini:** Writing – review & editing, Supervision. **Massimo Santarelli:** Writing – review & editing, Supervision. **Giuliana Mattiazzo:** Resources, Supervision.

#### Declaration of Competing Interest

The authors declare that they have no known competing financial interests or personal relationships that could have appeared to influence the work reported in this paper.

## Supplementary data

Supplementary data to this article can be found online at <https://doi.org/10.1016/j.ecmx.2022.100274>.

## References

- [1] UNFCCC. CP.26 Glasgow Climate Pact. Cop26, p. 1–8; 2019. [Online]. Available: [https://unfccc.int/sites/default/files/resource/cop26\\_auv\\_2f\\_cover\\_decision.pdf](https://unfccc.int/sites/default/files/resource/cop26_auv_2f_cover_decision.pdf).
- [2] Sharif A, Raza SA, Ozturk I, Afshan S. The dynamic relationship of renewable and nonrenewable energy consumption with carbon emission: A global study with the application of heterogeneous panel estimations. *Renew Energy Apr.* 2019;133: 685–91. <https://doi.org/10.1016/j.renene.2018.10.052>.
- [3] Bogdanov D, Ram M, Aghahosseini A, Gulagi A, Oyewo AS, Child M, et al. Low-cost renewable electricity as the key driver of the global energy transition towards sustainability. *Energy* 2021;227:120467.
- [4] Jacobson MZ, Delucchi MA, Bauer ZAF, Goodman SC, Chapman WE, Cameron MA, et al. 100% Clean and Renewable Wind, Water, and Sunlight All-Sector Energy Roadmaps for 139 Countries of the World. *Joule* 2017;1(1):108–21.
- [5] International Energy Agency (IEA). *World Energy Outlook 2021*; 2021. [Online]. Available: [www.iea.org/weo](http://www.iea.org/weo).
- [6] Child M, Bogdanov D, Breyer C. The role of storage technologies for the transition to a 100% renewable energy system in Europe. *Energy Procedia* 2018;155:44–60. <https://doi.org/10.1016/j.egypro.2018.11.067>.
- [7] Dowling JA, Rinaldi KZ, Ruggles TH, Davis SJ, Yuan M, Tong F, et al. Role of Long-Duration Energy Storage in Variable Renewable Electricity Systems. *Joule* 2020;4(9):1907–28.
- [8] L. Schratzenholzer, “The energy supply model MESSAGE,.” *Int. Inst. Appl. Syst. Analysis, Res. Report*, vol. 81–31, no. December, 1981, doi: 10.1016/0377-2217(83)90165-0. <https://pure.iiasa.ac.at/id/eprint/1542/1/RR-81-031.pdf>.
- [9] R. Loulou, G. Goldstein, A. Kanudia, and U. Remme, “Documentation for the TIMES Model Part I: TIMES Concepts and Theory,.” 2016. Accessed: Oct. 23, 2020. [Online]. Available: [https://iea-etsap.org/docs/Documentation\\_for\\_the\\_TIMES\\_Model-Part-I\\_July-2016.pdf](https://iea-etsap.org/docs/Documentation_for_the_TIMES_Model-Part-I_July-2016.pdf).
- [10] Wiese F, Bramstoft R, Koduvere H, Pizarro Alonso A, Balyk O, Kirkerud JG, et al. Baltimore open source energy system model. *Energy Strateg Rev* 2018;20:26–34.
- [11] Hunter K, Sreepathi S, DeCarolis JF. Modeling for insight using Tools for Energy Model Optimization and Analysis (Temoa). *Energy Econ* 2013;40:339–49. <https://doi.org/10.1016/j.eneco.2013.07.014>.
- [12] Pfenninger S, Pickering B. Calliope: a multi-scale energy systems modelling framework. *J Open Source Softw* 2018;3(29):825. <https://doi.org/10.21105/joss.00825>.
- [13] Howells M, Rogner H, Strachan N, Heaps C, Huntington H, Kypreos S, et al. OSeMOSYS: The Open Source Energy Modeling System. An introduction to its ethos, structure and development. *Energy Policy* 2011;39(10):5850–70.
- [14] Kato E, Kurosawa A. Evaluation of Japanese energy system toward 2050 with TIMES-Japan - Deep decarbonization pathways. *Energy Procedia* 2019;158: 4141–6. <https://doi.org/10.1016/j.egypro.2019.01.818>.
- [15] Yue X, Patankar N, Decarolis J, Chiodi A, Rogan F, Deane JP, et al. Least cost energy system pathways towards 100% renewable energy in Ireland by 2050. *Energy* 2020;207:118264.
- [16] Trondheim HM, Niclasen BA, Nielsen T, Da Silva FF, Bak CL. “100% Sustainable Electricity in the Faroe Islands: Expansion Planning through Economic Optimization. *IEEE Open Access J Power Energy* 2021;8(August 2020):23–34. <https://doi.org/10.1109/OAJPE.2021.3051917>.
- [17] Laha P, Chakraborty B. Cost optimal combinations of storage technologies for maximizing renewable integration in Indian power system by 2040: Multi-region approach. *Renew Energy* 2021;179:233–47. <https://doi.org/10.1016/j.renene.2021.07.027>.
- [18] Rady YY, Rocco MV, Serag-Eldin MA, Colombo E. Modelling for power generation sector in Developing Countries: Case of Egypt. *Energy* 2018;165:198–209. <https://doi.org/10.1016/j.energy.2018.09.089>.
- [19] English J, Niet T, Lyseng B, Keller V, Palmer-Wilson K, Robertson B, et al. Flexibility requirements and electricity system planning: Assessing inter-regional coordination with large penetrations of variable renewable supplies. *Renew Energy* 2020;145:2770–82.
- [20] McPherson M, Tahseen S. Deploying storage assets to facilitate variable renewable energy integration: The impacts of grid flexibility, renewable penetration, and market structure. *Energy* 2018;145:856–70. <https://doi.org/10.1016/j.energy.2018.01.002>.
- [21] Colbertaldo P, Agustin SB, Campanari S, Brouwer J. Impact of hydrogen energy storage on California electric power system: Towards 100% renewable electricity. *Int J Hydrogen Energy* 2019;44(19):9558–76. <https://doi.org/10.1016/j.ijhydene.2018.11.062>.
- [22] Cebulla F, Haas J, Eichman J, Nowak W, Mancarella P. How much electrical energy storage do we need? A synthesis for the U.S., Europe, and Germany. *J Clean Prod* 2018;181:449–59. <https://doi.org/10.1016/j.jclepro.2018.01.144>.
- [23] Lopian P, Markewitz P, Robinius M, Stolten D. A review of current challenges and trends in energy systems modeling. *Renew Sustain Energy Rev* 2018;96:156–66.
- [24] Ringkjøb HK, Haugan PM, Solbrenke IM. A review of modelling tools for energy and electricity systems with large shares of variable renewables. *Renew Sustain Energy Rev* 2018;96(August):440–59. <https://doi.org/10.1016/j.rser.2018.08.002>.
- [25] Lund H, Arler F, Østergaard P, Hvelplund F, Connolly D, Mathiesen B, et al. Simulation versus optimisation: Theoretical positions in energy system modelling. *Energies* 2017;10(7):840.
- [26] Balyk O, Andersen KS, Dockweiler S, Gargiulo M, Karlsson K, Næraa R, et al. TIMES-DK: Technology-rich multi-sectoral optimisation model of the Danish energy system. *Energy Strateg Rev* 2019;23:13–22.
- [27] Poncelet K, Delarue E, Six D, Duerinck J, D’haeseleer W. Impact of the level of temporal and operational detail in energy-system planning models. *Appl Energy* 2016;162:631–43.
- [28] Lai CS, Locatelli G, Pimm A, Wu X, Lai LL. A review on long-term electrical power system modeling with energy storage. *J Clean Prod* 2021;280:124298. <https://doi.org/10.1016/j.jclepro.2020.124298>.
- [29] Wyrwa A, Suwala W, Pluta M, Raczyński M, Zysk J, Tokarski S. A new approach for coupling the short- and long-term planning models to design a pathway to carbon neutrality in a coal-based power system. *Energy* 2022;239:122438.
- [30] Pavičević M, Mangipinto A, Nijss W, Lombardi F, Kavvadias K, Jiménez Navarro JP, et al. The potential of sector coupling in future European energy systems: Soft linking between the Dispa-SET and JRC-EU-TIMES models. *Appl Energy* 2020;267: 115100.
- [31] Gabrielli P, Gazzani M, Martelli E, Mazzotti M. Optimal design of multi-energy systems with seasonal storage. *Appl. Energy* 2018;219(October 2017):408–24. <https://doi.org/10.1016/j.apenergy.2017.07.142>.
- [32] Kotzur L, Markewitz P, Robinius M, Stolten D. Time series aggregation for energy system design: Modeling seasonal storage. *Appl Energy* 2018;213(January): 123–35. <https://doi.org/10.1016/j.apenergy.2018.01.023>.
- [33] Welder L, Ryberg DS, Kotzur L, Grube T, Robinius M, Stolten D. Spatio-temporal optimization of a future energy system for power-to-hydrogen applications in Germany. *Energy* 2018;158:1130–49. <https://doi.org/10.1016/j.energy.2018.05.059>.
- [34] Limpens G, Moret S, Jeanmart H, Maréchal F. EnergyScope TD: A novel open-source model for regional energy systems. *Appl Energy* 2019;255(July):113729. <https://doi.org/10.1016/j.apenergy.2019.113729>.
- [35] Nahmmacher P, Schmid E, Hirth L, Knopf B. Carpe diem: A novel approach to select representative days for long-term power system modeling. *Energy* 2016;112: 430–42. <https://doi.org/10.1016/j.energy.2016.06.081>.
- [36] P. Nahmmacher, E. Schmid, and B. Knopf, “Documentation of LIMES-EU - A long-term electricity system model for Europe,.” 2014. [Online]. Available: [https://www.pik-potsdam.de/en/institute/departments/transformation-pathways/models/limes/DocumentationLIMES-EU\\_2014.pdf](https://www.pik-potsdam.de/en/institute/departments/transformation-pathways/models/limes/DocumentationLIMES-EU_2014.pdf).
- [37] Gardumi F, Shivakumar A, Morrison R, Taliotis C, Broad O, Beltramo A, et al. From the development of an open-source energy modelling tool to its application and the creation of communities of practice: The example of OSeMOSYS. *Energy Strateg Rev* 2018;20:209–28.
- [38] KTH Royal Institute of Technology - School of Industrial Engineering and Management division of Energy Systems Analysis and KTH Royal Institute of Technology, “OSeMOSYS Documentation,.” 2019.
- [39] M. Welsch, *Enhancing the Treatment of Systems Integration in Long-term Energy Models*. Doctoral Thesis, no. January; 2013.
- [40] OSeMOSYS Community, “GitHub OSeMOSYS Pyomo.” [https://github.com/OSeMOSYS/OSeMOSYS\\_Pyomo](https://github.com/OSeMOSYS/OSeMOSYS_Pyomo) (accessed Mar. 08, 2022).
- [41] Stadler P, Ashouri A, Maréchal F. Model-based optimization of distributed and renewable energy systems in buildings. *Energy Build* 2016;120:103–13. <https://doi.org/10.1016/j.enbuild.2016.03.051>.
- [42] Kotzur L, Markewitz P, Robinius M, Stolten D. Impact of different time series aggregation methods on optimal energy system design. *Renew Energy* 2018;117: 474–87. <https://doi.org/10.1016/j.renene.2017.10.017>.
- [43] GitHub - revised OSeMOSYS-pyomo with new timeframe. [https://github.com/riceardonovo/OSeMOSYS\\_pyomo/tree/OSeMOSYS\\_EC\\_20220118](https://github.com/riceardonovo/OSeMOSYS_pyomo/tree/OSeMOSYS_EC_20220118).
- [44] Liu Y, Yu S, Zhu Y, Wang D, Liu J. Modeling, planning, application and management of energy systems for isolated areas: A review. *Renew Sustain Energy Rev* 2018;82:460–70.
- [45] Engelken M, Römer B, Drescher M, Welpel I. Transforming the energy system: Why municipalities strive for energy self-sufficiency. *Energy Policy* Nov. 2016;98: 365–77. <https://doi.org/10.1016/j.enpol.2016.07.049>.
- [46] Clean Energy for EU Islands et al. *Agenda per la Transizione Energetica Isola di Pantelleria*. Pantelleria; 2020.
- [47] Novo R, Minuto FD, Bracco G, Mattiazzo G, Borchiellini R, Lanzini A. Supporting Decarbonization Strategies of Local Energy Systems by De-Risking Investments in Renewables: A Case Study on Pantelleria Island. *Energies* Feb. 2022;15(3):1103. <https://doi.org/10.3390/EN15031103>.
- [48] W. Cole and A. W. Frazier, “Cost Projections for Utility- Scale Battery Storage Cost Projections for Utility- Scale Battery Storage,.” *Natl. Renew. Energy Lab.*, no. June, p. NREL/TP-6A20-73222, 2019, [Online]. Available: <https://www.nrel.gov/docs/fy19osti/73222.pdf>.
- [49] Capacity4dev, “Sustainable Energy Handbook.” <https://europa.eu/capacity4dev/public-energy/wiki/sustainable-energy-handbook> (accessed Oct. 20, 2020).
- [50] International Renewable Energy Agency (IRENA). *Future of solar photovoltaic*; 2019.
- [51] International Renewable Energy Agency. *Future of wind*; 2019.
- [52] de Moura GNP, Legey LFL, Howells M. A Brazilian perspective of power systems integration using OSeMOSYS SAMBA – South America Model Base – and the bargaining power of neighbouring countries: A cooperative games approach. *Energy Policy* Apr. 2018;115:470–85. <https://doi.org/10.1016/j.enpol.2018.01.045>.

- [53] Taliotis C, Rogner H, Ressler S, Howells M, Gardumi F. Natural gas in Cyprus: The need for consolidated planning. *Energy Policy* 2017;107(April 2017):197–209. <https://doi.org/10.1016/j.enpol.2017.04.047>.
- [54] Marocco P, Ferrero D, Lanzini A, Santarelli M. The role of hydrogen in the optimal design of off-grid hybrid renewable energy systems. *J Energy Storage* 2022;46: 103893. <https://doi.org/10.1016/j.est.2021.103893>.
- [55] Guerra OJ, Eichman J, Denholm P. Optimal energy storage portfolio for high and ultrahigh carbon-free and renewable power systems. *Energy Environ Sci* 2021;14 (10):5132–46. <https://doi.org/10.1039/d1ee01835c>.