

Reduction of supply temperature in existing district heating: A review of strategies and implementations

*Original*

Reduction of supply temperature in existing district heating: A review of strategies and implementations / Guelpa, E.; Capone, M.; Sciacovelli, A.; Vasset, N.; Baviere, R.; Verda, V.. - In: ENERGY. - ISSN 0360-5442. - ELETTRONICO. - 262A:(2023), p. 125363. [10.1016/j.energy.2022.125363]

*Availability:*

This version is available at: 11583/2971345 since: 2022-09-16T09:18:21Z

*Publisher:*

Elsevier

*Published*

DOI:10.1016/j.energy.2022.125363

*Terms of use:*

openAccess

This article is made available under terms and conditions as specified in the corresponding bibliographic description in the repository

*Publisher copyright*

(Article begins on next page)



# Reduction of supply temperature in existing district heating: A review of strategies and implementations

E. Guelpa<sup>a,\*</sup>, M. Capone<sup>a</sup>, A. Sciacovelli<sup>b</sup>, N. Vasset<sup>c</sup>, R. Baviere<sup>c</sup>, V. Verda<sup>a</sup>

<sup>a</sup> Politecnico di Torino, Corso Duca Degli Abruzzi 24, Turin, Italy

<sup>b</sup> University of Birmingham, Edgbasto, B15 2TT, UK

<sup>c</sup> CEA - Commissariat à l'énergie atomique et aux énergies alternatives, 17 Av. des Martyrs, Grenoble, France

## ARTICLE INFO

### Keywords:

Thermal networks  
Supply temperature reduction  
Low-temperature district heating  
Lowering  
District heating temperature  
Real cases  
Founded project

## ABSTRACT

Most of the existing district heating systems are second and third generation and operate with supply temperature above 80–100 °C. To meet long-term decarbonization targets, existing networks should be transformed into low-temperature systems in a cost-effective manner. This paper presents a critical review on the strategies that can be adopted to reduce the supply temperature in existing district heating networks taking advantage of previous studies (both research projects and scientific papers) and forerunner experiences. This includes a review of the constraints met during transition and the possible strategies/actions to overcome them, along with the actions to boost the change.

The analysis shows that there is often significant room for improvement by exploiting the oversizing of network, substations and terminal units along with techniques, previously adopted with other aims, for a proper infrastructure/operation modification. Temperature reductions can be achieved without groundbreaking infrastructural modifications. Therefore, acting on specific subnetworks (the way usually adopted) is not the only way to proceed; this can be done in entire networks by adopting proper changes of perspective, policies and preliminary analysis. In the meantime, there is still need for specific approaches to estimate the main limitations and the corresponding best actions to implement in a specific network.

## 1. Introduction

In the past, district heating (DH) were mainly based on high temperature heat carriers [1]: 1st generation DH fed by steam ( $T \gg 100$  °C), 2nd generation DH fed by pressurised overheated water ( $T > 100$  °C), 3rd generation DH, fed by hot water ( $T < 100$  °C). Nowadays the tendency is to design DH systems to operate with low and ultra-low temperature heat carriers and even temperatures close to the ambient (neutral temperatures) [2,3]. Low temperature DHs operate between 50 and 70 °C [4]; ultra-low temperature DHs operate between 35 and 50 °C [4]; neutral DHs operate at a temperature of about 20–35 °C. In low and ultra-low temperature systems, heat pumps at consumer level are typically used to match temperature requirements on the secondary side, especially for the production of domestic hot water [5]. In the case of neutral temperatures, heat pumps and chillers are used to increase and decrease the water temperature to supply heating and cooling [5]. Future networks are expected to be able to handle multiple energy entries with different quality and quantities [6].

The importance of adopting low temperature heat carriers in DH is currently undisputed, since it allows to: a) exploit renewable heat, often available at low temperature [7] b) valorize industrial waste heat (usually available at low temperature) [8,9] c) increase the efficiency of technologies for heat production (e.g. combined heat and power plants and heat pumps) and d) reducing thermal losses.

The use of lower supply temperature has been significantly debated and 4th and 5th generation DH system are becoming quite widespread in Europe. In the literature, several works exist on low temperature and ultra-low temperature DH. mainly on the estimation of the next generation DH potentials [2,10], the economic aspects [4,11], real-case analysis [12–14] and possible strategies to move towards new generation DH [15]. Guidelines for the design are provided in Ref. [16].

The main problem in the transition towards low temperature DH concerns the existing systems, which have been designed to operate with high temperature heat carriers (steam or superheated/hot water). In Europe DH installed capacity is, for the greater part, 2nd and 3rd generation, therefore, to fulfil decarbonization targets [17] is essential to

\* Corresponding author.

E-mail address: [elisa.guelpa@polito.it](mailto:elisa.guelpa@polito.it) (E. Guelpa).

modify them [18]. In the transition of existing DH two main issues arise. The first is that DH is a massive infrastructure (i.e. thousands large-size pipelines in the ground and hundreds/thousands substations) with high investment cost (due also to the difficulty of pipe installation); therefore, the complete renovation of existing networks (intended as the reconstruction of the entire system) is usually not economically sustainable. The second is that the pipe diameters, the network topology, the thermal substations, the heating system circuit and the building heating devices have been chosen to operate with high temperature water; therefore a careful investigation are required before proposing a sudden change. In particular there are various issues, discussed later in the paper, that must be addressed especially in the large/complex DH systems. A realistic transition must be planned such that limitations due to existing networks, substations and heating systems can be overcome through tailored solutions in a cost-effective manner.

In the literature and in the web various aspects can be found:

- attempts and experiences on supply temperature reduction of real systems, generic or strongly specific, that include different issues or part of the infrastructure.
- results of projects related to specific aspects (e.g. integration of low temperature networks into the return line of high temperature DH, or potential of supply temperature reduction for supplying existing radiators)
- discussion about the implementation of low temperature system (such as the excellent work done in the framework of ANNEX TS2 IEA-DHC [19])
- analyses focused on a) specific water congestions problems or b) issues on substation heat exchange not strictly related to supply temperature reduction of existing DH; these works are important since similar issues can be encountered in different context of DH renovation.
- analysis aimed at demand peak shaving not related to supply temperature reduction, that can be useful in the context here analysed.

In the authors' opinion, this represents a vast body of literature in the area that needs to be structurally and coherently reviewed.

The aim of this analysis is therefore to collect, elaborate and integrate all these disaggregated aspects to review the strategies that will enable the transition of existing DH systems towards lower supply temperatures. The critical integration of all these aspects represents the originality of the present review paper that goes beyond other good review papers available that mainly aimed to new systems or refurbishment of small portions of the network. The paper is targeted to experts in the specific field, researchers facing the topic for the first time or people working on the DH sector. The various constraints that can be encountered during the transitions are considered and the possible actions that can be used to overcome the constraints are discussed on the basis of the various works available in the literature.

The paper is structured as follows:

- Section 2 reviews the benefits that can be achieved by reducing the supply temperature of existing DH.
- Section 3 is about the limitations that can be encountered in network (Section 3.1), in the substations (Section 3.2) and in the buildings (Section 3.3), including, for each section a series of possible solutions to overcome the limitations.
- Section 4 discusses the solutions that can be adopted to modify the demand in order to make the system suitable to supply temperature reduction (i.e. demand flexibility)
- Section 5 reports a possible action plan to be followed for implementing supply temperature reduction in existing network.

## 2. Benefits of reducing supply temperature in district heating

The benefits of reducing the supply temperature in DH is addressed

in different papers [4,20,21]. Cost reduction gradient (CRG) is a key performance indicator, often adopted in the literature [19,22], that is very useful to address supply temperature reduction benefits for a technology or a DH. CRG is obtained by dividing the reduction of the levelized cost of heat (of the entire system or a generation technology) by the temperature reduction. CRG describes the economic benefits in terms of reduced cost per 1 °C temperature reduction and per MWh. In Ref. [23] the CRG was calculated in 27 Swedish DH networks; it ranges from 0.04 to 0.38 €/ (MWh°C), on average 0.12 €/ (MWh°C). Considering a temperature gap of 30 °C cost reduction are of the order of 1.5–17 €/MWh [19]. For a medium size DH (500 GWh/y), the supply temperature reduction of 10 °C provides on average yearly cost reduction of 0.6 M€. According to Ref. [20] the benefits that can be achieved are 0.55 €/ (MWh°C) for the DH network with higher transmission capacity, 0.11 €/ (MWh°C) with reduced mass flow and 0.07 €/ (MWh°C) with reduced heat losses.

The various benefits can be identified, as schematized in Fig. 1, in various sections of the system: heat production side (i.e. characterized by different sources and technologies), heat transport side (i.e. the infrastructure used to carry, store and distribute heat) and consumption side (i.e. all type of buildings).

### 2.1. Heat production side

On the supply side, reduction of supply temperature contributes:

- a) to improve the second law efficiency of most heat generation assets (both conventional technologies and renewable heat sources); indeed, if the source temperature reduces, the Carnot coefficient in the denominator of the second law efficiency increases (Eq. (1)), where the subscripts b and s refer respectively to the building and the source).

$$\eta_{II} = \frac{\Phi_b \left(1 - \frac{T_0}{T_b}\right)}{\Phi_s \left(1 - \frac{T_0}{T_s}\right)} \quad (1)$$

- b) the utilization of low-temperature sources that are not suitable for high temperature networks.

The effects of lower supply temperatures are different depending on the technologies and for the most relevant technologies are summarized below:

- *Steam-based Combined Heat and Power plants (CHP)* can improve the power-to-heat ratio due to the possibility to continue the expansion to lower pressure and temperature levels; this leads to more electricity production with the same heating demand, increasing the second law efficiency up to 25% when supply temperature reduces of 30 °C [24–26]. Depending on the penetration rate, CRG is found to be between 0.08 and 0.26 €/ (MWh°C) [20,27].
- Heat production from *waste incineration* may be increased by means of direct condensation of flue gases [1]. The same applies for *biomass fuels* [24]. In these cases, the heat recovered is expected to increase by up to 25% [24,28].
- Concerning *heat pumps*, despite the upper limit for the sink temperature in the last years has reached higher level (about 160 °C [29]), the adoption of lower condensation temperature results into a significant increase of the coefficient of performance (COP) of the technology. COP variations strongly depends on the heat transfer fluid and cycle/technology adopted. In a simple loop heat pump the real COP increase of 20–25% if the supply temperature is reduced from 100 °C to 70 °C [29] while the CRG is 0.6 €/ (MWh°C) [20].
- Reduction of the supply temperature increases the potentials for integration of *waste heat* from industrial processes or cooling

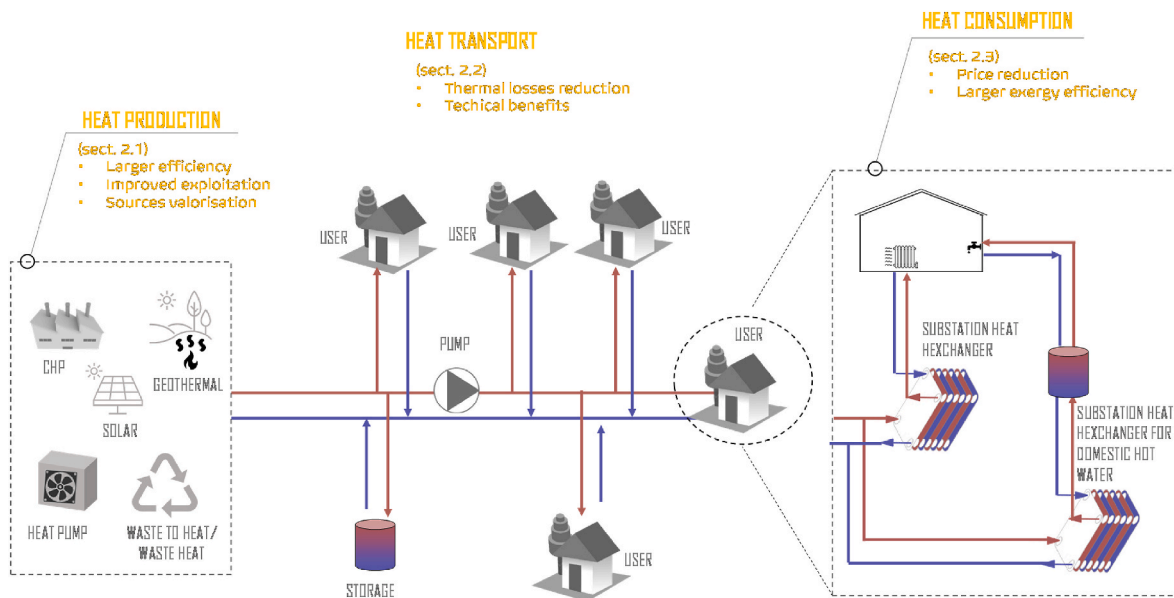

Fig. 1. Benefits achieved by supply temperature reduction in existing networks.

processes [1,24,28]. The analysis in Ref. [30] shows operational cost savings at system level were 0.6–7.3% for data centers, when high shares of waste heat are adopted in DH.

- Additional *geothermal heat* can be integrated in the system [1,28]; this option can produce relevant results, since large geothermal resources are available in Europe at temperature levels among 40–80 °C [28]. In the case of a very low temperature geothermal field such as GSHP (ground-source heat pump), a reduction of temperature setpoints for heat provision will increase performance through the COP improvement as well as reduce thermal stress of the soil, extending the borefield lifetime. CRG estimated in Ref. [20] for the technology is 0.67 €/ (MWh°C).
- *Solar energy* can be used to supply low temperature networks [18–20]. Lower temperatures have a positive effect on the conversion efficiency of thermal collectors [28]. CRG estimated in Ref. [31] for solar thermal energy in Sweden is 0.64 €/ (MWh°C).

When considering *Heat Only Boilers*, the supply temperature reduction has a negative effect on the production units. Indeed, two main problems may occur: a) outlet temperature lower than 60 °C can cause corrosion due to the condensation of water vapor in the flue b) large temperature gradient can cause the cracking of the flame tube. However the supply temperature reduction is done with the aim of exploiting waste heat and renewable sources in DH. Heat Only Boiler are not expected to play a crucial role in the future energy systems. Probably this could represent a problem during the transition (when the target temperature has not yet been reached and production units adopted are the old ones) more than in case of complete transition. CRG for other technologies are reported in Ref. [20]. Recent results show that considering sensitivities in geothermal, industrial waste heat, heat pumps, solar thermal and configurations CGR ranges between 0.07 and 0.74 €/ (MWh°C) [32] and 0.25 to 0.8 €/ (MWh°C) [33].

## 2.2. Heat transport side (i.e. DH network)

Low operating temperatures lead to lower heat losses along the DH network [34,35]. It has been estimated that low temperatures alongside with a well-designed network have the potential to reduce heat losses by up to 75% with respect to conventional designs [36], while reductions up to 35% are possible in case of existing networks [37]. In Ref. [38], the transition to low temperature DH is shown to enable the reduction of the

heat losses up to 25%. In Ref. [39] heat-losses are shown to decrease of about 68% when passing from 80 °C on average to 48 °C on average, considering the expansion of a DH with a low temperature sub-network. Low supply temperatures lead to smaller temperature differences between supply and return, resulting either a reduction of the network capacity or in an increase of the mass-flow rates and, consequently, of the pressure drops along the network [25], as discussed in Section 3.1. Nevertheless, applications to real case-studies prove that, while the heat saved by reducing the supply temperature is considerable, the increase in the energy required for pumping can be contained and limited [38].

Besides the reduction in the heat distribution losses, there are additional advantages [19,28,40]: a) the chance to use plastic pipes in areas with low pressure that are more cost effective than conventional metal based pipes (this is particularly suitable for network extensions), b) reduction of the risk of water boiling in the network, c) reduction of the pipe thermal stress, resulting in lower maintenance costs d) lower risk of pipe leakages e) lower risk of scalding human skin during pipe maintenance. Furthermore, *Thermal storage units* in low temperature systems present the advantage of lower thermal losses; on the other hand, the storage capacity of sensible thermal storage units reduces as the temperature difference between the supply and the return side decreases. Temperature reduction also enable the possibility of long-term storage (e.g. seasonal), since costs for storing above boiling temperature water are prohibitive.

## 2.3. Heat consumption side (i.e. costumers/buildings)

Reduction of network supply temperature improves the match between the temperature levels of heating demand and supply; this contributes to reduce the system energy/exergy losses [10], as shown in Fig. 2c that shows the exergy degradation in different DH generations. Considering that the future building heating demands will not require high temperatures [28] as well as existing retrofitted building will require lower temperature this effect will be even more significant. A further potential benefit that the consumers may have from supply temperature reduction is the possible reduced prices that could be obtained due to efficiency improvements in the system [25]. Furthermore, this enables the possibility of connecting small scale heating prosumers selling the surplus heat [25].

In general, it is well established that lowering supply temperature may completely change the range of opportunities for the heat

production/recovery in a certain DH context and can significantly increase the performances of the technologies adopted. However, in the CRG calculation for a specific network, it is important to consider that CGR in multi-generation systems may change depending on the position of the various technologies. An important point to consider is that in fossil fuel driven networks the main benefits when reducing supply temperature are the increase of the efficiency and the losses reduction; these two benefits could be considered not sufficient to justify the efforts required for transition. Actually, the impact completely changes and rises when different opportunities that the supply temperature reduction enable are considered. For this reason, the transition should be driven at first by a change of perspective, in order to overcome the resistance to change and open pathways of new opportunities.

### 3. Constraints in supply temperature reduction

When an existing network, as is, is supplied with lower temperature than the design value, various problems can arise that can limit further temperature reduction, acting as constraints. Therefore, these will be called *limitations* in the following sections. These limitations can be grouped into three main types, as shown in Fig. 2, depending on the part of the infrastructure that is involved:

- **Limitations at network level:** reduction in the supply temperature causes a smaller supply-return temperature difference. This leads to an increase of circulating mass flow; depending on its extent, the increase in circulating mass flow rate could be potentially unfeasible in some cases. The problem is exacerbated in large networks (~100

km or more), where supply flow rates are inherently large. This issue is discussed in Section 3.1.

- **Limitations at substation level:** A second problem concerns the capability of the substation to exchange the required amount of heat with the building heating circuit, when it is operated at a lower temperature. Operations of the existing heat exchangers with lower supply temperature and larger mass flows could reduce the power provided to the building and may lead further issues also related to the provision of domestic hot water. This type of limitation is discussed in Section 3.2
- **Limitations at building level:** The third problem is related to the limitations due to the heating devices available in the buildings (e.g. the radiators). Low temperature heat could limit the thermal power exchanged in the heating devices. This problem is discussed in Section 3.3.

In sections 3.1, 3.2 and 3.3 not only the limitations related to network, substation and building are discussed, but also the actions that can be done to overcome them. In order to have a clear view of the actions that can be performed, Table 1 is proposed. For each action, information on the specific opportunities which it offers and the constraints of the action are reported. Furthermore, the infrastructure and the activities required are included, along with a qualitative scale on relative economic burden (that provides indications on a possible order of implementation of the proposed solutions), and the conditions which make each action suitable. For sake of clarity, also the section of the present paper where the specific action is discussed, is included in the last column.

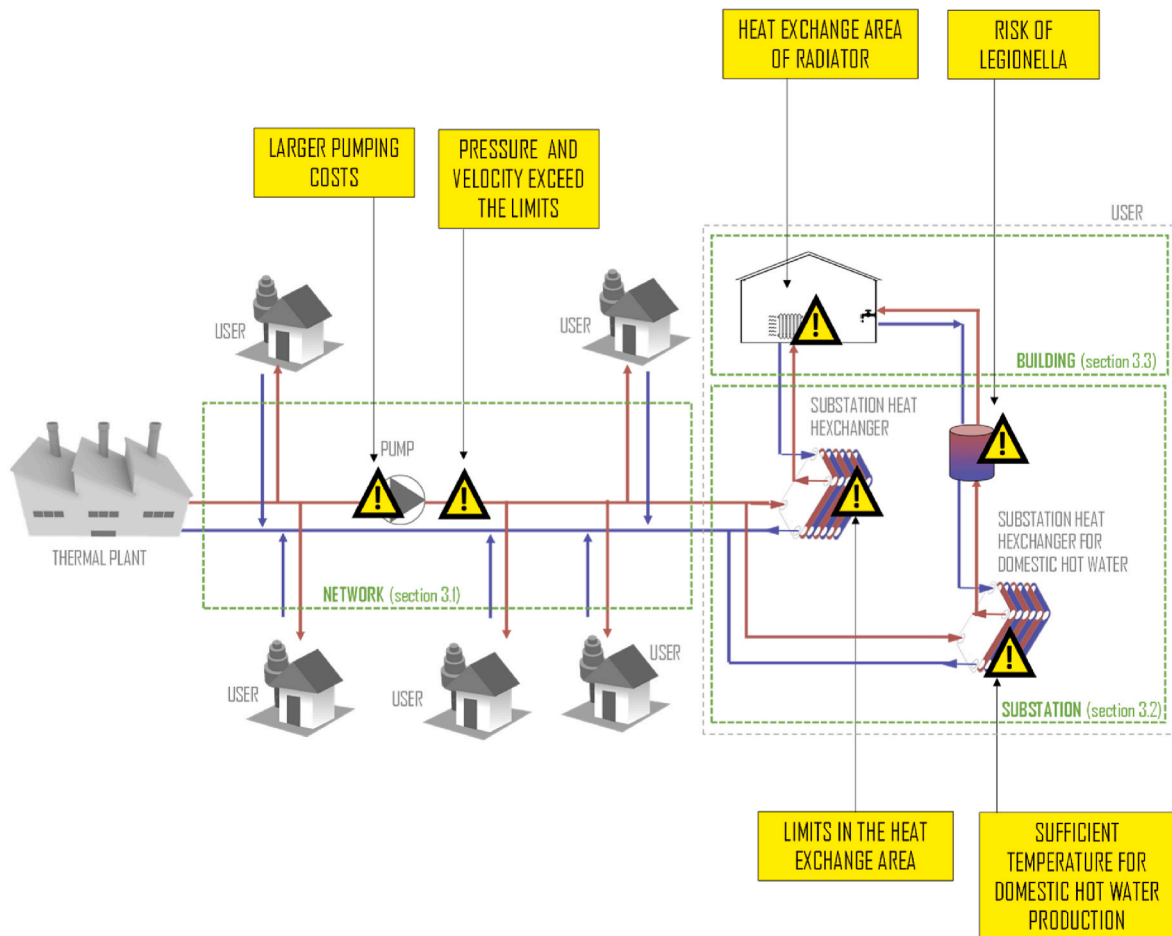

Fig. 2. Schematic of the limitations and issues encountered when reducing the supply temperature in existing DH.

**Table 1**  
Actions to overcome the limitations met while reducing the DH supply temperature.

	Action	Opportunities	Action constraint	Activity required	Infrastructure required	Economic burden	When suitable	Ref.	Section of the present paper
Take advantage of the existing	Take advantage of the over-dimensioning of DH network pipelines	no hardware modification is generally required	the over-dimensioning is usually limited	Tests on the over-dimensioning availability	–	€	always when the problem is dominant in the network side	[25]	3.1.2 a
	Take advantage of the over-dimensioning of thermal substations	no hardware modification is generally required	the over-dimensioning is usually limited	Tests on the over-dimensioning availability	–	€	always when the problem is dominant in the network side	[64]	3.2.1
	Take advantage of the over-dimensioning of heating devices (e.g. radiators) including the exploitation of all the available devices	no hardware modification is generally required	the over-dimensioning is usually limited	Tests on the over-dimensioning availability	–	€	always when the limiting aspect is the radiator exchange area	[65, 66]	3.3
Actions on pumping	Different pumping strategy	Quite simple to apply. Minor changes are generally required	the position/number of the pump is defined	Analysis on the new pumping strategy to be adopted	Eventual modification of the control system	€	when suboptimal pumping control is adopted and if pumps are big enough	[52, 67]	3.1.2 b
	Add new pumps in strategic positions	to avoid large pressure downstream the previous pump	only solve the problem of the pressure, not on the velocity	Analysis on the position where a pump should be added	New pumps	€€	when there are suitable locations for adding new pumping group	[45]	3.1.2 b
Modification of the network topology	Substitution of pipelines characterized by bottlenecks	easily solve problem of local bottlenecks acting on both pressure drop and velocity	only allows to solve local problem	Analysis to clarify where precisely the bottlenecks occur	Minor excavation pipe substitution and new pipes	€€	when local bottlenecks are present in the network	[45]	3.1.2 c
	Additional pipelines	significant increase of the supplied mass flow	Additional pipelines (like twin pipes) must be laid considering the building position	Study on the position/shape of the new pipelines	New pipelines and significant excavation work (and economic expenditure)	€€€€€	when the other strategies are not sufficient	[68]	3.1.2 c
	Additional pipes to create looped network	Possible modification of the water supply management	This should be managed by a proper tool for the optimal water distribution	Specific fluid-dynamic analysis on the effects of the loop creation	New pipes, excavation work (and economic expenditure) and proper control tools	€€€	when preliminary studies show that a ring could improve the delivered mass flow rate	[40]	3.1.2 b
Actions on additional production/storage units	Local thermal storage to reduce the mass flow processed by the thermal plants	part of the mass flow processed locally	space availability	study on the best position/volume/type of the additional storage	installation of a new storage	€€€€	when the problems are localized on specific areas	[69]	4 b
	Local heat supply systems, such as heat pumps or heat only boilers.	part of the mass flow processed locally	space availability	study on the best position/capacity of the additional heat supply system	installation of a local heat supply system	€€€-€€€€ (depending on the installed technology)	when the problems are localized on specific areas	[45]	4 c
	adoption of prosumers after bottlenecks	part of the mass flow processed locally	prosumer availability	study on the most suitable buildings to become prosumers	technologies for the prosumer inclusion (proper bidirectional substation)	€€€	when the problems are localized on specific areas	[70]	4 d
Actions on the demand	Adoption of demand side management	reduce the mass demand during peaks; minor changes in the hardware are generally necessary	1) action only on the peaks 2) comfort to be guaranteed 3) occupants acceptance	Preliminary analysis to select the best type of demand response (e.g. load shifting, different substation control strategy)	1) data sensor and communication system 2) a software to select the best/smart demand response	€ (if the data sensor and communication system is already available) - €€	1) in case of large peak demand 2) preferable when data sensor and communication system is already available	[71]	4 a
	incentivation for focused retrofitting	reduce the heat and mass flow required	building owners take the final decision	Money for incentivitation; find proper legacy way to intervene	–	€	when there are limitations related to the heating devices as well as the	–	3.2.1

(continued on next page)



Table 1 (continued)

	Action	Opportunities	Action constraint	Activity required	Infrastructure required	Economic burden	When suitable	Ref.	Section of the present paper
Actions on the substation	proper substation control strategy	reduce the mass demand during peaks	1) action only on the peaks 2) comfort to be guaranteed	analysis to estimate proper control strategy	Proper control system	€	building circuit (pipes and substation) 1) in case of large peak demand 2) availability of a control system to implement new strategies	[72]	4 a
	install proper system for the early detection of fault/fouling and inefficiencies	improve the temperature gap at the substation to reduce the supplied mass flow rate	limited effects on the thermal flow increase	Implementation of an approach for the early fouling detection or a specific measuring system	data sensor and communication system	€ (if the data sensor and communication system is already available) - €€	nearly always (when the problem at the substation is dominant)	[73, 74]	3.2.1
	increase the heat exchange area in problematic substations	improve the temperature gap in substations representing bottlenecks for supply temperature reduction	action on specific buildings	Analysis on the most problematic substations	new heat exchangers	€€	when the limited heat exchanger area of specific substations limits the supply temperature reduction	[75]	3.2.1
Actions at building level	to feed suitable buildings using the return line	reduce the mass flow required	availability of buildings with only low temperature heating devices	Analysis to find the suitable buildings	Minor changes in the substations	€	when low temperature heating devices are present in some buildings	[76]	3.2.1
	Fault detection of the heating system (e.g. under-dimensioned radiator) and correction	Improve the heat exchanged with the building	Only for building side limitation in case of fault operations	A model for the assessment of fault operations	Depends on the fault estimated	€ (if the data sensor and communication system is already available) - €€	when the radiator heat exchange limits the supply temperature reduction	[77]	3.3
	Improve the radiators control strategy	Improve the heat exchanged with the building	Only for building side limitation	An analysis to estimate the best control approach.	New control strategy	€ (if the data sensor and communication system is already available) - €€	when the radiator heat exchange limits the supply temperature reduction	[78]	3.3

### 3.1. Limitations at DH network level and solution to overcome them

#### 3.1.1 Limitations at DH network level

When the circulating mass flow rate increase, due to the lower temperature difference, pressure losses also rise due to increased fluid flow friction across the network; this creates two main consequences.

**Energy for pumping increase:** the operational expenditure for water pumping across the DHN drastically increases, proportionally to the cube of the mass flow rate. An interesting analysis reported in Ref. [38] shows the variation of thermal losses and pumping power for two DH design (high and low energy density) when reducing the supply temperature from 80 °C to 50 °C. Annual pumping energy increases in the range 54–58% depending on the network energy density. This is, in absolute terms, a variation of 1.33–1.48 MWh/y. Concerning the thermal losses, a decrease of 25% is obtained in both the cases, which means an annual reduction of 20–40 MWh, depending on the energy density. Furthermore, an analysis is done in case of fault conditions, such as fouling, or bad substation setting. In these cases, the impact of pumping power increase is larger. Therefore, the impact of heat losses increase can be considered the major, especially in case of high energy density network and non-fault operations. Also considering an exergy viewpoint considering a CHP DH, as shown in Ref. [41], the supply temperature reduction is beneficial. A significant lowering of the supply temperature from 120 °C to 60 °C almost halved the supplied exergy (from 5927 kW to 3175 kW), with an exergy efficiency of the DH that reaches the 60%. Since the increase of the pumping power is a disadvantage that should be considered, in case of network refurbishment or expansion must be remembered that, as shown in Ref. [22], a good dimensioning of a low temperature DH allows low energy consumption for pumping (between 1 and 2% in the considered network).

In light of the results, the reduction of the supply temperature usually provides benefits larger than the drawbacks; furthermore if the exploitable resources are at a limited temperature (e.g. renewable sources, waste heat from industrial plants) or the efficiency of the production plant significantly changes with temperature (e.g. heat pumps, cogeneration plants) the modification is more beneficial.

**Water congestion:** Another consequence is that high mass flow rates can cause water congestions in the pipelines [42,43]. As congestions is meant larger mass of water flow in pipelines that are designed for lower mass flow values; specifically, this causes a two-fold effect:

- High velocity values are reached in some pipes of the network where the diameters were selected to deliver significantly smaller mass flow rates. The phenomenon can lead to mechanical vibrations due to the excessive water velocity. Therefore, a threshold value exists for the velocity, that cannot be exceeded. This means that some of the areas of the network might be not properly supplied by the DHN (Fig. 3 a).
- Water streams assume higher absolute pressure immediately downstream the pumping stations to overcome the increased pressure losses caused by the higher mass flow rates. Networks and its components are built to guarantee operation up to a certified maximum pressure. Therefore an increase of mass flow rate due to supply temperature reduction might lead to exceeding maximum operating pressure in the network [44]. Nonetheless, the maximum allowed pressure (selected in the design phase of DH) must be guaranteed in

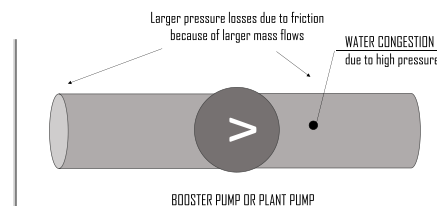
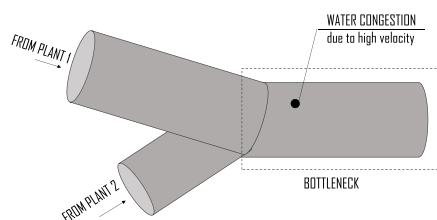

Fig. 3. Water congestion: a) high velocity (left) b) high pressure (right).

all the network operations. This is therefore a second technical limitation (Fig. 3b).

As an example (1 km long network, with a design water velocity of 3 m/s), Fig. 4 reports the variation of the water flow velocity (y-axis) and the pressure losses (y-axis) in the supply pipelines of a large DH networks as a function of temperature difference between the supply and return line (x-axis). Both velocity and pressure increases while the temperature difference decreases considering a friction factor of 0.016. The strong non-linear trends show that the velocity and pressure losses variations significantly depend on the current temperature gap [45]. A 10 °C reduction from 60 °C to 50 °C causes a velocity increase of 0.7 m/s and a pressure increase of 2.5 bar. A 10 °C reduction from 40 °C to 30 °C causes instead a velocity increase of 1.5 m/s and a pressure increase of 7 bar. This means that if the reduction of supply temperature initially appears less impactful on the network viewpoint, but further reductions could encounter significant limitations in their implementation.

As stated, very few papers about the water congestion and how to deal them exist. The main work (not related to supply temperature reduction) is [45], where various simulations were performed (using the software NetSim [46], through a quasi-dynamic simulation) on a fictive case area, situated in the outskirts of a DH network in a city in southern Sweden, using real data. The work analyses four scenarios, considering various strategies to overcome the constraints, like increasing the supply temperature (therefore the opposite effect which is searched in the present analysis) and the pumping power, local heat supply, better cooling in substations, demand side management and adoption of larger pipes. The economic burden of the measures has also been considered. Results show that measures including the demand side (like demand response) can be very advantageous solutions from an economic perspective and that if there are prosumers in the water congestion areas it makes sense to exploit them. Another outcome of the analysis is that the best solution to implement depends on the network topology (shapes, diameters, and length), the pressure profiles and the user thermal demand.

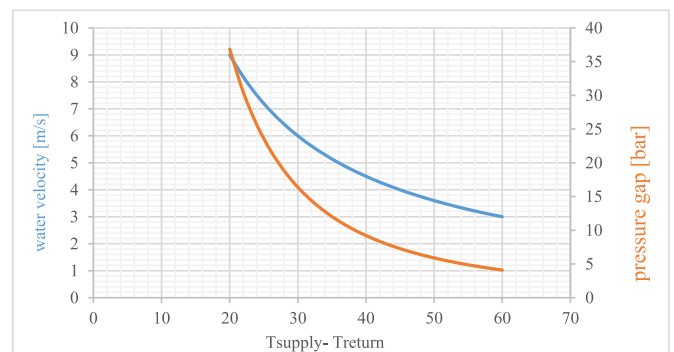

Fig. 4. Effects of the supply temperature reduction on the network velocity and pressure losses.



### 3.1.2. How to address the transition at network level

The main solutions that can be adopted to overcome the limitations at network level are here discussed. Additional actions, done on the demand of the plant, are discussed in Section 4 since these provide benefits to all the three levels (network, substation and building).

- Exploitation of the network overdimensioning:** Network pipelines are often overdimensioned. This is particularly true in case of distribution network (i.e. sub-networks). An analysis of the gradual transformation of existing DH systems into grids with supply temperature below 100 °C has been done in Poland. Considering the DH system in Łomża (east Poland) the nominal supply temperature in DHS was decreased from 121 °C to 109.8 °C [39] only through the exploitation of the network overdimensioning. Results show that mass flow variations have been dramatically decrease improving the season hydraulic stability of the DH. Before the implementation mass flow ranged in 250–1322 m<sup>3</sup>/h (varying by a factor of over 5 over the season), after variation ranged in 912–1501 m<sup>3</sup>/h (varying of 64% during whole season). The work have been developed within the LowTEMP project and the final goal is to reach the temperature 96.3 C in 2022 [47].
- Actions on the pumping system:** the actions on the pumping system (Table 1 in *Actions on pumping*) are here discussed through consideration of the DH network cones. Fig. 5a represents a schematic of the pressure cones of an existing DH (black line) and an existing DH with lowered supply temperature (orange dashed line). The two pressure cones are characterized by similar behaviour, although they are slightly different: a) the supply pressure line decrease is larger when supply temperature is lower, due to larger friction (higher mass flow); the same applies for the return line; b) the pressure losses at the buildings (vertical lines at x = building-to-plant distance, which include the intrinsic losses of the substation and the delta pressure required to balance the network [48]) are larger in case of larger mass flow rates (orange line); c) the vertical increases due to booster pumping groups in the supply line depend on the regulation strategy adopted.

In Fig. 5a, two pressure limits are also reported. The upper value is the limit due to the technical issues previously discussed, while the lower value is either a) the water boiling pressure at a certain temperature in case of overheated water networks (2nd generations) or b) the operation pressure in case of 3rd to 5th generation networks (that operates at pressures slightly higher than the environmental).

By considering the orange line in Fig. 3a, it is clear that larger pressure drops in the substations, occurring in case of lower supply temperature, may cause the exceedance of the pressure limits. Two possible ways to overcome the limitations acting on the pressure control are shown in Fig. 5b and c. In Fig. 5b the available pumps are used in a different way: the pumping gap at the thermal plant is reduced and the booster pumping stations provide larger gaps (especially the last one). The improved strategy can be achieved by practical considerations or by using a pumping system optimizer, as shown in Refs. [49–51]. The adoption of a proper control strategy can provide significant reduction of the pumping cost [52] and enable the water provision also in case of strong fluidynamic water congestion. This is discussed in Ref. [53], where the adoption of smart pump control is shown to provide significant benefits to reach the correct amount of water during malfunctions (e.g. leakages or pipe/pump breakup). The applicability of such strategies depends on the position and the capacity of the booster pumps and may then require the replacement of existing assets. In addition, this option may not be sufficient in case of significant mass flow changes. In these cases, the addition of a further booster pumping group can be useful to allow the correct operations of the network. The pressure cone of the case with an additional pumping group is reported in Fig. 5c. In this case, an additional vertical line is present in the supply line; this allows keeping the curve close to the upper limit without exceeding it.

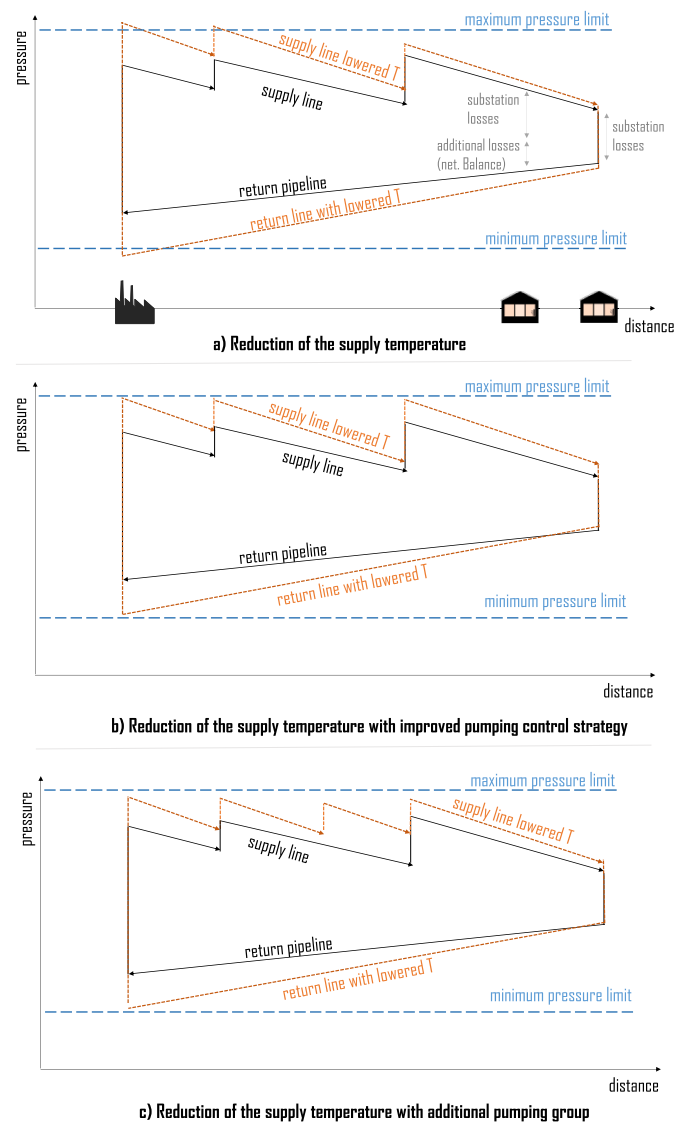

Fig. 5. Pressure cones for an existing DH (black) and the same DH with lowered supply temperature (orange).

- Actions on the network topology:** An option to solve the water congestion in the pipelines concerns the modification of the network topology (in Table 1 *Modification of the network topology*). Modifications can be performed in different ways.

The less impactful modification consists of the *substitution of the bottleneck pipes* (i.e. where the congestion occurs) with one with larger diameters. This modification easily allows solving local congestions in a sustainable way from the economic perspective. However, this kind of modification only solves local water congestion.

If the water congestion is distributed along the network, topological modifications must be more consistent. In the case an entire pipeline is congested, a possible option consists in the *modification/addition of new pipelines*, that can be installed in parallel to the existing one, or with a different topology. In this case, the economic burden is significant and practical considerations could prove extremely difficult. In order to select the best shape of the additional pipelines, proper tools for the estimation of the optimal expansion can be used. They should include the limitations due to the presence of buildings, while the cost should be minimized. For these aims, the approaches adopted for the best network topology estimation [54–56] and diameter estimation [57] can be used, properly adapted to the specific goal. A real case where the pipes have

been substituted leading to a supply temperature reduction is Sonderby, Hoje Taastrup (Denmark), part of a network characterized by 75 non refurbished detached houses with floor heating. In this case, the pair of single pipes were replaced as the annual heat losses of the grid accounted for about 40% by a new TwinPipe system [58]. This allowed a supply temperature reduction to about 52–55 °C, much lower than the previous average temperature of 80 °C [39,59]. In Aarhus also the pipelines have been substituted in a small portion of the network that has been used as a test case. This is done with the aim of reducing operating temperature ( $T_{\text{supp}} = 60$  °C and  $T_{\text{ret}} = 30$  °C) through the use of a mixing shunt at the connection to the main network [58].

Another opportunity consists in the addition of pipes in order to create ring networks (loops). As discussed in Ref. [40], the use of ring networks allows to tackle the issue of pressure imbalance for the end-users by installing valves which permit to achieve the specified mass flows. This allows a different exploitation of the network.

An option that can be applied to new network is the *triple-pipe configuration*, where the supply line is split in two parts which are operated at two different temperature levels [23,60]. This configuration is usually adopted by separating the DHW line from space heating line. Actually this can also be applied to connect buildings requiring water at different temperature levels [61]. The implementation of this option is not straightforward in case of existing networks, since the connection between pipes and the problematic substations must be modified in order to connect the heat exchanger with the network at the proper temperature.

For all the 3 options considered (a,b and c), a preliminary analysis is required to estimate potential in a benefits-costs perspective. A representative simulation of the water dynamics within the pipelines is a necessary ingredient, as shown in Refs. [62,63]. This should be based on the steady-state momentum equation for an incompressible fluid, applied to the pipes, including the gravimetric contribution (Eq. (2)) and the steady-state mass conservation equation applied to all the junctions (Eq. (3)). The equations applied to all the network pipes/junctions allows to find the set of mass flow rates and pressures within the network.

$$(P_{\text{in}} - P_{\text{out}}) = \frac{1}{2} \frac{f}{D} L \frac{G |G|}{\rho S^2} + \frac{1}{2} \sum_k \beta_k \frac{G |G|}{\rho S^2} - \tau \quad (2)$$

$$\sum G_{\text{in}} - \sum G_{\text{out}} = G_{\text{ext}} \quad (3)$$

### 3.2. Substations

#### 3.2.1. Substation heat exchanger: constraints and solutions to the constraints

In the thermal substations, reduction of supply temperature and increase of mass flow rates can lead to two main issues. The first is that, below a certain value of the inlet temperature, it is not possible to exchange the required amount of heat, independently from the mass flow rate selected. This means that a threshold value exists for the supply temperature in existing DH substations. The second issue concerns the maximum value of mass flow rate that can be processed in the substations. In fact, technical limitations exist on the maximum mass flow rate which is allowed. There are several options to overcome limitations in substation heat exchangers.

a. *Exploitation of the substation overdimensioning*: As for the DH pipelines, the substation are often overdimensioned. This happens mainly for two reasons: a) DH operators are usually not aware of the exact temperature of the supply water required by a building, therefore the installations are done with a certain level of oversizing to avoid comfort issues. b) During years energy renovation is carried out in buildings and their thermal demand reduces. Another reasons, especially in East-Europe countries, like Hungary, in some countries DH were designed for operating with larger capacities and when the social housing projects ceased the infrastructure resulted to be

overdimensioned [79]. Considering the reduction of the supply system that have been implemented in Łomża (east Poland) [39] results show that the substations are oversized, on average, of above 2 times. In this case study supply temperature decrease of 11 °C (from 121 °C to 109.8 °C has been achieved). This problem has also been specifically analysed in Ref. [64]. In this work an approach is proposed to estimate how the existing thermal substations limit the supply temperature reduction of DH networks; the proposed approach only relies on the substation data. Results show that: a) it is not mandatory to know the details about the heat exchanger (exchange area, transmittance, type) to estimate the potential temperature reduction and b) substation designed for supply temperature of 120 °C can reduce the supply temperature of 5–15 °C also in the most severe climate conditions (design conditions). The analysis only concerns substation limitations; a quantitative analysis of the bottlenecks related to the network and the building side in order to compare the limitations is highly needed.

b. *Fault/Fouling detection*: Past studies have shown that there are faults in the operation in about 70% of the substations [80]. While considering possible solutions to the limitations due to the heat exchanged in the substations, it is important to consider the fouling problem (i.e. an undesired deposition of material on the internal surface of the heat exchanger). Fouling is a relevant problem [81] which unavoidably occurs in the life of the substation [82]; the worldwide costs for fouling in heat exchangers is estimated to be of the order of 4.5 billion \$/year in the field of the crude oil distillation. Fouling factor increase ( $f_i$  and  $f_o$  in eq. (4)), causes the decrease of the global heat transfer coefficient that lead a reduction of the heat exchanged  $\Phi$ .

$$\varphi = \frac{\Delta T_m \log}{\frac{1}{A_i h_i} + \frac{R_{f_i}}{A_i} + \frac{s}{A_k} + \frac{R_{f_o}}{A_o} + \frac{1}{A_o h_o}} \quad (4)$$

This means that to exchange the same value of heat it is necessary to use larger mass flow rates (and in case of severe fouling deposition the heat demand cannot be met). Using experimental data of an existing thermal substation, it is possible to obtain the graph in Fig. 6. Data before and after cleaning are compared in terms of temperature difference (supply minus return) as a function of the thermal power exchanged. In case of a fouled heat exchanger, the heat exchange reduces and the control system tends to open the valve to increase the mass flow rate in order to keep the thermal power constant (see Fig. 7). As a consequence, the temperature gap between supply and return

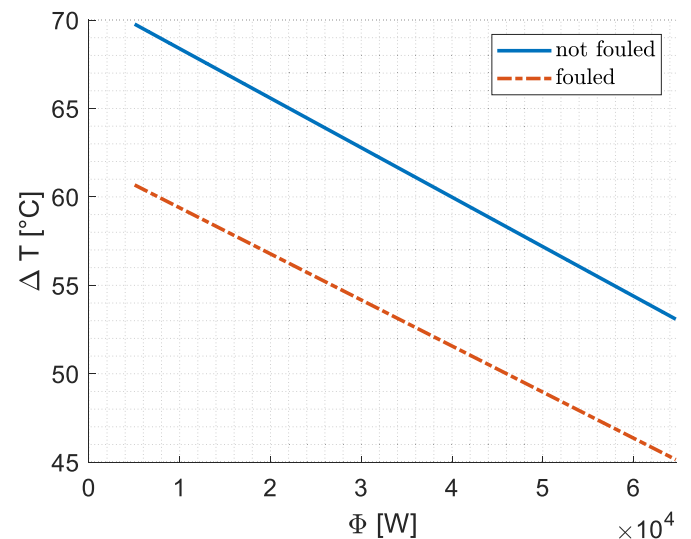

Fig. 6. Temperature gap (supply-return) on an existing thermal substation before (fouled) and after (not fouled) fouling cleaning.

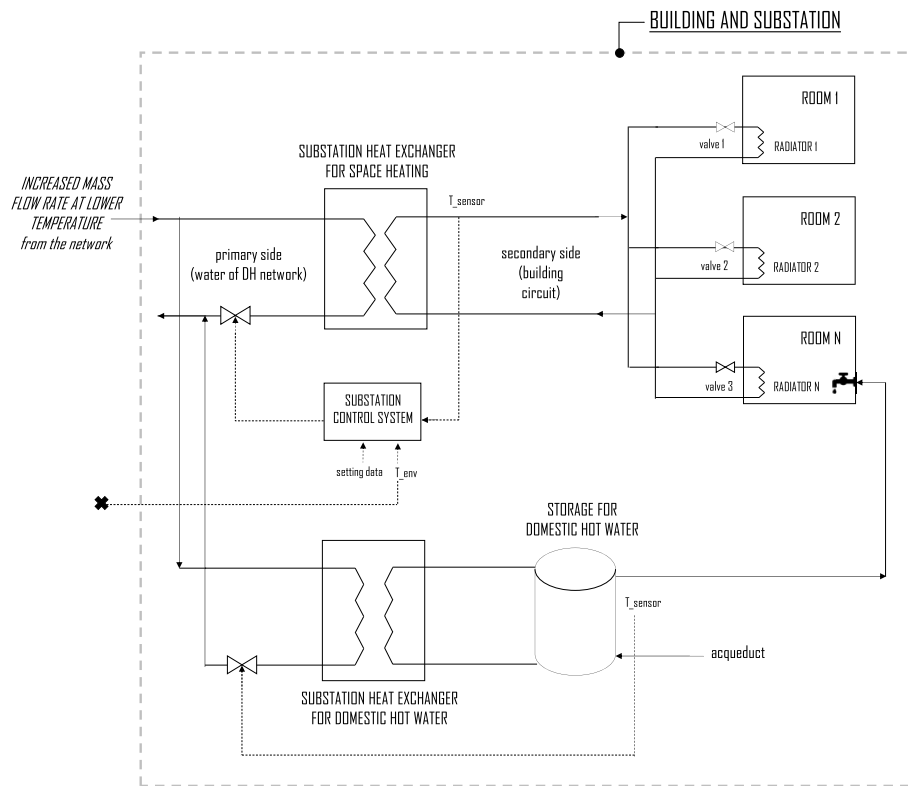

Fig. 7. Schematic of substation and buildings.

reduces. A difference of the order of 10 °C in temperature gap occurs between fouled and not fouled heat exchanger. This means that during the reduction of the supply temperature, in case of fouled heat exchanger, the limitation at substation level may become dramatically more impactful.

Since fouling can be a crucial limitation in the reduction of the supply temperature, it is important to check for possible deposition before to proceed with modifications to the operation of substations. In case of large networks characterized by a large number of buildings, a tool for the fouling early detection can be applied. Tools can require specific measurement systems as shown in Refs. [83,84], or rely on the substation data [73]. It has also to be considered that fouling significantly affects the substation data analysis [74]. Therefore, when data are utilized in the control system, or a data analysis is done, it is highly recommended to consider this problem. Concerning more general fault detection these can include broken valves, controllers and actuators or the presence of unintentional by-passes. An approach to detect general malfunctions is presented in Ref. [85]. It is important in this framework a continuous monitoring of the data detected at substation level.

c. **Inefficiencies detection and solution:** A proper analysis, through temperature and mass flow rate data, to investigate the real operation of the thermal substation could be useful to capture eventual problems. Typical inefficiencies consist in 1) too high set-point temperature 2) oversized circulation pumps (which lead to larger mass flow in the building heating circuit) 3) inappropriate use of by-passes and mixing valves. In order to avoid these problems, an analysis of the substation data should be adopted; this can include an analysis and comparison of the evolution in time of thermal consumption, set-point temperature, building circuit mass flow (for instance in case of consumption decrease it is probability possible to reduce the set point temperature). This may help to find room for improvement for the temperature reduction and correct set-point temperatures (maybe individuating the lowest possible value) as well as the individuation of heat exchanger that should be substituted and the

individuation of shunt of by-passes to be removed. Details on possible actions are investigated in various paper [86–88]; often inefficiencies and fault detection are both considered in the same analysis since sometimes is difficult to make a specific distinction. In Gleisdorf (Austria) supply temperature has been reduced from 90 °C to 83 °C by proper correction of fault, fouling and inefficiencies in the thermal substations [89,90]. This has enabled the possibility of exploiting solar and biomass along with the fossil fuel based supply.

- d. **Actions on the most problematic devices:** Another way to enable reduction supply temperature, overcoming limitations concerning the substations, is the estimation of the heat exchangers which mostly limit the supply temperature (i.e. those requiring heat at higher temperature, also after the fault elimination). As shown in the analysis performed on 15 substations, reported in Ref. [64], the minimum supply temperature allowed in various heat exchangers can significantly differ. If some of them are much larger than the others, an option (after the fouling detection check) consists in acting on the most limiting substations through a) *substitution of heat exchangers* b) installation of additional heating devices/storages or c) considering implementation of *incentivation for focused retrofitting* (discussed in section 4 related to the demand modification).
- e. **Additional heating devices/storages:** Other options, discussed in Section 4 consist in a) installation of local thermal storage, that can be useful when the demand evolution of the limiting substation significantly varies during the day and b) using local heaters or heat pump to provide to the buildings the additional required heat.

### 3.2.2. Domestic hot water production and Legionella issue

In houses or commercial buildings, temperature reductions below 60–70 °C is generally limited by the domestic hot water requirements and specifically by the Legionella problem. Legionella is a bacterium growing in water and humid places, that, if inhaled, can cause problems such as cold, high fever, pneumonia and can even lead to death. The proliferation of Legionella depends on the water temperature, the quantity and the stagnation of the water inside pipes and storages. This

**Table 2**  
Funded projects having among the aims the temperature reduction in existing DH.

ref	Acronym	Name	Type	Period	Analysis of T reduction in existing DH	Specific aims related to supply temperature reduction of existing DH
[142]	LOWTDH	Leave 2nd generation behind: cost effective solutions for small-to-large scale DH networks	IEA-DHC Annex XIII	2020–2023	Main goal	Analyse bottlenecks on supply temperature reduction (related to substations and network) and find strategies to overcome them integration of low temperature networks into the return line of high temperature net
	CASCADE	CASCADE: A comprehensive toolbox for integrating low-temperature sub-networks in existing district heating networks	IEA-DHC Annex XIII	2020–2023	Main goal	
[143]	LowTEMP	Low Temperature DH for the Baltic Sea Region	European Union (European Regional Development Fund)	2017–2020	Main goal	promoted the installation of so-called 4th generation DH networks
	LowTEMP 2.0	Low Temperature DH for the Baltic Sea Region 2.0	European Union (European Regional Development Fund)	2021	Main goal	promoted the installation of so-called 4th generation DH networks
[144]	–	Transformation Roadmap from high to low temperature DH	IEA-DHC Annex XI	2014–2017	Main goal	Significant experimental analysis on potential of current radiator system to address supply temperature reduction
[149]	–	Stepwise transition strategy and impact assessment for future DH systems	IEA-DHC Annex XII	2017–2020	Main goal	Experimental analysis on 10 buildings shows the potentials of the existing equipment to reduce heating device supply temperature
[150]	OPTITRANS	Optimized transition towards low-temperature and low-carbon DH systems	IEA-DHC Annex XIII	2020–2023	Main goal	Facilitating the transition to low temperature DH providing adequate support for long-term decision-making to DH companies
[145, 146]	TEMPO	TEMPerature Optimisation for Low Temperature DH across Europe	European Project Horizon 2020	2019–2022	Among the goals of the project	Analyses bottlenecks related to the customer side
[147]	FLEEXYNETS		European Project Horizon 2020	2015–2018	Among the goals of the project	use of thermal energy from the return pipes to feed neutral networks
[151, 152]	RES-DHC	Transformation of existing urban district heating and cooling systems from fossil to renewable energy sources	European Project Horizon 2020	2020–2023	Among the goals of the project	Address temperature reduction on existing networks
[5]	–	Towards 4th Generation DH: Experiences with and Potential of Low Temperature DH	IEA-DHC Annex X	2011–2014	Among the goals of the project	Extending the adoption of 4GDH to existing buildings connected to existing high temperature DH.
[153]	–	Heat Pumps for Domestic Hot Water Preparation in Connection with Low Temperature DH	Funded by EUDP	2011–2013	Among the goal of the project	Study the use of heat pumps to increase the water temperature of ultra-low T DH for domestic hot water

11

problem must be considered for the temperature selection of domestic hot water preparation. In Ref. [91], it is proven that the temperature range that causes the highest Legionella proliferation is between 30 and 45 °C. Usually domestic hot water is kept at temperatures that are higher than the user need (>50 °C [14]) in order to avoid legionella problem. Concerning low temperature DH ( $T < 60$  °C), the problem of legionella can be faced by the installation of heating devices such as instantaneous local heaters or heat pumps [25,92].

Interesting analyses concern the benefits that can be achieved by adopting lower temperature coupled to treatment for the legionella elimination. Analyses are done in Refs. [93,94], where various scenarios for domestic hot water production (substation with instantaneous heat exchanger or substation with micro tank) are analysed from energy exergy and economic viewpoint, considering both comfort and Legionella issues. Different temperature levels of DH are taken into account. Results show that instantaneous heat exchangers are the best solutions in all cases except for ultra-low temperature DH where tank solution perform better. Furthermore small volume approach are often used to avoid Legionella, e.g. less than 3 L, as done in the pilot in Wednesbury, north west of Birmingham (UK), Stavanger (Østre Hageby), Norway and Aarhus (Lystrup), Denmark [95]. Concerning the existing 1st and 2nd generation networks this usually not represents the main limiting problem since that supply temperature cannot be reduced so much.

In [96], a conventional DH is analysed from energy, economic and exergy perspective at different temperatures; for the analysis three heat pump solutions applying R134a and R744 are considered as local heat source. Results show that conventional solutions at the lowest possible temperature have the highest exergy efficiency and lowest cost. Hot storages are proved to have a positive impact on the exergy efficiency of the system; the best solution is proven to be the storage located on the DH circuit side. This means that low temperature DH represents an efficient solution also when domestic hot water, along with space heating, is required.

In this framework, the project *Heat Pumps for Domestic Hot Water Preparation in Connection with Low Temperature District Heating* [23] funded by EUDP (details are reported in Table 2) studied the adoption of heat pumps to increase the water temperature of ultra-low temperature DH to supply domestic hot water. The project aims at the development of a pilot (in Birkerød north of Copenhagen) with an ultra-low temperature DH equipped with a heat pump (micro-booster) for domestic hot water preparation. The project shows that the system operated according to the expectations except for some minor problems to be taken into account (e.g. problems with regulating the existing circulation system for domestic hot water). The performance of the system results to be satisfactory and the solution resilient.

### 3.3. Building heating devices (constraints and possible solutions)

Most of the residential buildings built in the 20<sup>TH</sup> century in Europe

use radiators as heating devices, especially in urban areas. Radiators of European dwellings are usually designed to operate with supply temperatures between 90 °C and 70 °C. The design is done considering the most severe condition in the specific location (usually in Europe between  $-5$  and  $-15$  °C depending on the climate area). Therefore, it is reasonable to expect that the typical space heating demand (excluded during the extremely cold day) can be met also by adopting lower supply temperature. The relation between the minimum supply temperature and the outdoor temperature for an existing substation is reported in Fig. 8. Supply temperature can be reduced of about 15 °C considering an outdoor temperature of 0 °C instead of  $-8$  °C (design conditions). Furthermore, often not all the available radiators are used in dwellings [97]. This means that there is large potential of *exploiting the oversizing and outnumber of heating devices*.

This is particularly true, if considering that often existing buildings are subjected to retrofitting measures after the DH connection. Analyses available in the literature [65,66] show that typical Danish and Swedish homes that have receive retrofitting measures can be supplied with low-temperature heat.

The topic has been significantly investigated by Ostegaard in his doctoral thesis [77]. The potential of current heating systems for low-temperature heating is investigated by analysing various case studies. Among the interesting results, a crucial outcome is that as much as 80% of heating systems are currently over-dimensioned. The analysis also highlights major problems related to the adopted control system. The main issues on the control system are hydraulic short-circuits, radiator thermostats not working optimally, occupants using the thermostats in the wrong way, and too small radiators. It has been shown that it is possible to overcome these issues by a) *improving the heating control* or b) *replacing critical radiators* that have large impacts on the overall return temperature. The *installation of thermostatic valves* can be considered as first step for improving the heating control.

An analysis of houses build in the 1990th, along with an overview of typical building constructions adopted, is reported in Ref. [98]. The results obtained from the analysis of 6 single-family houses show that for more than 97% of the year, these can be supplied with temperature below 50 °C.

Both the simulation and test measurements done on existing buildings, reported in Ref. [14], show that 1980th Danish single-family houses can be heated with supply temperatures as low as 45 °C for the main part of the year. This means that, during peak period, the temperature must be increased [99] while most of the time the network can be fed with warm water.

The analysis reported in Ref. [100] shows that temperature reduction of 15 °C can be achieved in case of typical oversized radiators. An experimental analysis on more than 100 radiators of an existing DH system [101] shows that in case of design temperature of  $-16$  °C, for an outdoor temperature of 5 °C or more all radiator systems have a supply temperatures of 55 °C or less, as expected in 4th generation DH. The

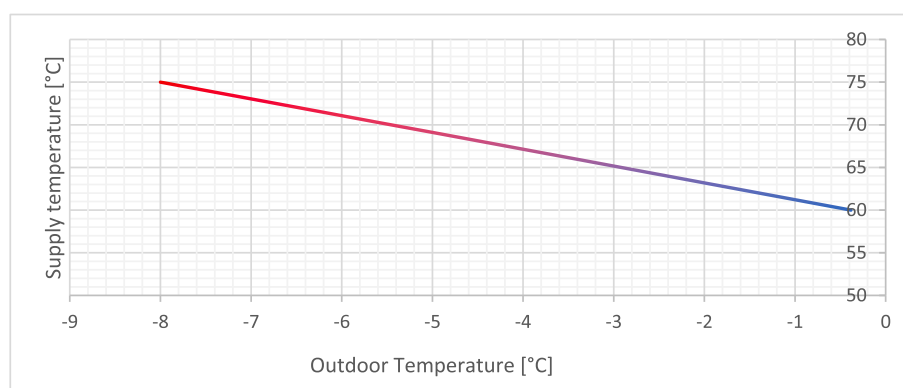

Fig. 8. Relation among the heating system supply temperature and the outdoor temperature.



analysis shown in Ref. [102] proves that the payback time for preparing existing space heating systems for low-temperature DH in Denmark is 1.2–4.3 years from an energy system perspective and 0.3–18.7 years for an individual DH customer. In Ref. [97] the exploitation of all the available radiators instead of portions (in the work it was measured was 70% the fraction of operated radiators) has been explored through a model of the radiator system. Results show that average supply and return temperatures of 44 °C and 30 °C, respectively, could be achieved in the heating system of a typical Danish building.

In order to overcome the limitations due to poor control, continuous *fault-detection analyses* should be implemented [77]. These can be done through control systems relying on the data measured with the available sensors. Actually, it is not straightforward to gather all the useful data since companies and energy agencies often cannot install sensors in buildings. For this reason the first pilots for supply temperature reductions are usually university campus. Consider, as examples, Kelowna [103] (Canada) and Oshawa Ontario Tech University [104] (Canada) and Zurich [105] (Switzerland). An interesting work in this regard is that performed in Ref. [78], where use of proper control (adjusting the temperatures according to demand) is shown to allow radiators in existing buildings to be supplied with lower temperature water also without any intervention in the thermal envelope.

Concerning the modelling of the radiators, a new model, suitable for different ranges of mass flow rates is proposed in Ref. [106]. In the future, proper models should be developed in order to reach suitable and reliable control tools and proper data collection system should be adopted. Furthermore, it is important that in case of building renovation in case these are connected to high temperature DH, proper design criteria are adopted to enable future exploitation of low supply temperature.

#### 4. Actions on the district heating network demand

Additionally to the actions discussed in section 3 (that were strictly related to the singular benefits on the network, the substation and the building) other solutions to overcome the constraints can be achieved by directly acting on the demand. In this case, some benefits are obtained at different levels (i.e. network, substations and buildings); for this reason these are organized in a separate section. The actions on the building

demand can be done with different approaches, here listed and discussed (along with the level of effects achievable) are specified in Fig. 9.

- a. **Demand side management.** Demand response (that are only the not definitive actions on the building demand) and the other demand side management techniques are born in the electric field for the modification of the user demand to achieve benefits on the production side [107,108]; afterwards, the same approaches have been applied to DH to modify the thermal request profile of buildings [109–112,112,113]. All the details of demand side management in DH are provided in a review paper [71]. Demand side management can be implemented in different ways:
  - Through retrofitting measures. In Ref. [114], a specific methodology for assessing supply temperature reduction in DH by using retrofitting measures is proposed. The analysis applied to the Klagenfurt DH (Austria) showed that retrofitting actions allows achieving return temperature reductions varying from 0.3 K (in the BaU scenario) to 1.2 K (in the ambitious retrofitting scenario), with standard deviation of about 4–4.5 K. Reduction of thermal distribution losses range between 5 MWh and 21 MWh [114].
  - Adopting different tariffs (dependent on the time of the day) to force the owners to change the heating system settings, as show in Ref. [115] where suggestions of new DH-tariff encouraging to utilise demand side management are proposed.
  - Changing the schedule of the heating system in the buildings. In the literature, various works (also a test in relevant environment [116]) have shown that thermal power peak reduction up to 25–30% [111] and reduction of primary energy needs up to 5% can be achieved.
  - Changing the set-up [117,118] or the control strategy [119] of the building substations, or by installing flow limiters. The last has been implemented in Boras (Sweden) and allowed to reduce the average supply temperature from 96 °C to 79 °C, along with operating pressure increase and inefficiency detection [19].

To adopt all the demand response techniques for enhancing supply temperature reduction, a preliminary work is required a) for properly selecting the new setting of the control system or b) for predicting the effects of the planned modification. In some cases, proper tools are used

Action on the demand modification	type	effects on..
Demand side management		network/substation/building
Additional thermal energy storage	Installed in the primary side	network
	installed in the building circuit	network/substation
Additional heat supply system	Installed in the primary side	network
	installed in the building circuit	network/substation
Inclusion of prosumer/low energy buildings		network

Fig. 9. Workflow for achieving supply temperature reduction in existing DH.



[120,121] with the aim of estimating the best settings, depending on the daily thermal demand, the schedule of the other buildings, etc. Targeted control actions for demand-side management are shown being attainable in Refs. [122,123], using measurements at a substation level. In the latter, the use of a model for the prediction of the expected thermal profile is required to estimate the proper control actions; in Ref. [124] various possible approaches and options are discussed. A new approach proposed in Ref. [125] consists in the overall management of the network by using the concept of the State of Charge of the buildings connected.

- b. **Thermal storage installation.** A widespread way to solve the problem of bottlenecks is the adoption of thermal storages [117,126] to store energy when the demand is low and to provide it when the demand is high. This can be very useful to reduce supply temperature in the case the demand is highly variable during the day (e.g. thermal peak during the morning hours or night setback). Various kinds of storages can be adopted to achieve this goal, as shown in the survey [69]; the most widespread technology is definitely the water storage. The storage volume must be properly selected in order to be able to achieve benefits, avoiding unsustainable investment costs [127, 128]. Thermal storage can be installed as centralized storage or as distributed storage (at building level). In the first case, the position of the thermal storage in the urban areas should be properly selected since this strongly influence the network fluiddynamic; indeed, if the concentrated storages are not properly located, these are not useful to overcome water congestion in the DH network.
- c. **Additional local heat supply systems.** Additional heat pumps or heat only boilers can be used for two specific aims: a) to recirculate water in the areas close to the buildings avoiding water congestion in the critical pipelines and b) to increase the water temperature. The second option is proper in case of areas characterized by similar limitations in terms of temperature levels at the substation or at the building level. In some cases, these two benefits can be achieved at the same time. In this case, the location of the local heat supply system, as well as the configuration of the heat pump configuration, as shown in Ref. [129], is crucial.
- d. **Enhance the connections of prosumers and exploitation of low energy buildings:** An interesting opportunity to reduce water congestion in networks consists in exploiting the possible presence of heat prosumers [130] (i.e. buildings that depending on time require or sell heat). These allows reducing the mass flow processed by the thermal plant, since a part of the mass flow rate is circulated directly in the prosumers (that act as plants, transforming return water into supply) instead of being transported up to the plants. In case the position of the prosumer is properly selected, this allows a reduction of the water passing through the bottlenecks. In case there are multiple prosumers, it could be useful to analyse which user is more suitable, as shown in Ref. [131]. In the analysis, results show that the optimal allocation corresponds to the network critical user since reduce the pumping power with an optimal hydraulic balance of the DH network. The analysis only shows that the prosumer must be managed by the network operator to avoid problems due to flow reversions and/or to pressures and mass flow distributions. In Ref. [70], it is shown that as the supply temperature from prosumers is usually low, this is compensated with larger mass flow rates and therefore higher velocities. The effect at a larger scale is to create a new pressure cone among the prosumers and the buildings served by the prosumer. Areas that are not reached by water from prosumers are managed according to the pressure of another plant; therefore, proper control strategies must be applied to allow a correct water circulation. This effect is reduced when water from the prosumers is mixed with supply water from the rest of the network; in this case, a proper pressure value must be guaranteed at the correct mass flow rate. Another effect, studied along with a DH company and discussed in Ref. [70], is that the prosumers may cause travelling temperature fronts leading to increased fatigue in the pipes; the analysis proves

that this phenomenon generally has little impact on the lifetime of the pipes. The inclusion of prosumers in large number requires the further development of bidirectional substations, to allow a bidirectional heat exchange in the two cases of consumer and producer operations [132]. In the case of buildings equipped with low temperature heating systems (e.g. building not requiring domestic hot water, buildings with radiant floor), it is possible to connect them to the return line (in series), such that the mass flow rate provided to the buildings is lower than that required in case of parallel connection.

## 5. Global approach for the supply temperature reduction

### 5.1. Possible action flow

A preliminary planning should be performed to achieve convenient solutions in the implementation of actions to reduce supply temperature in an existing network. A possible global procedure that can be followed is reported in Fig. 10.

The proposed procedure consists in the following steps.

- a) The first step concerns the estimation of how much the DH parts are oversized respect to the current use. The question is “How much the network/substations/radiators are oversized?” Depending on the answer to this question it is possible to understand what is the supply temperature reduction that can be achieved without any modifications. This issue can be addressed through numerical analysis, allowing to directly estimate the temperature reduction potential of a network using realistic data.
- b) In case the exploitation of oversized devices is not sufficient to reach satisfactory temperature reduction, it is useful to analyse if significant thermal peaks exist during the daily period (analysing the overall daily demand and estimating the peak entity respect to the base load). This step is very important since the limitations occurs during the peak hours. The elimination of the peaks allows to use low supply temperature in all the DH operations (not only in the off-peak hours) and this allows to avoid installation of inefficient capacity. Peak elimination can be done acting on the demand using the techniques described in Section 4. It could make sense to consider during the selection of the peak reduction approach, which is the part of the system affected (Fig. 9); in fact, if, for instance, a centralized thermal storage is used, part of the network, the substation and the building, will continue to see the peak. If DSM is adopted, the peak is shaved at all the system levels.
- c) Further supply temperature reductions can be achieved only if specific modifications in the DH system are performed. In order to find the best actions to be implemented, a preliminary analysis is required to estimate where the main limitation occurs: in the network, in the substation or in the buildings. Depending on which part of DH limits the supply temperature reduction a list of actions is proposed (Fig. 10 STEP 3). The actions are ordered following the implementation easiness and cost. In general, in case the first action cannot be applied to the system, it is possible to skip to the first applicable modifications:
  - **NETWORK:** If the supply temperature cannot be reduced due to water congestion in the DH network, the cheaper way to solve the problem is to modify the pumping strategy, or, if not sufficient, to add one or more pumps. Secondly, depending on the problematic that is encountered there are different options. In case the congestion is localized in a precise pipe it makes sense to consider modifications of the pipelines in the bottlenecks or the addition of new pipelines. In case the problem is related to a wider area or other options to be considered are the inclusion of an additional local heat supply system or the exploitation of prosumers or low exergy buildings to feed some buildings by using return water. This allows to have water recirculation avoiding the overload the



**ACTION FLOW**

TO REDUCE SUPPLY TEMPERATURE OF OPERATIONS AN ENTIRE EXISTING DISTRICT HEATING (SMALL TO LARGE CASE PROCEDURE)

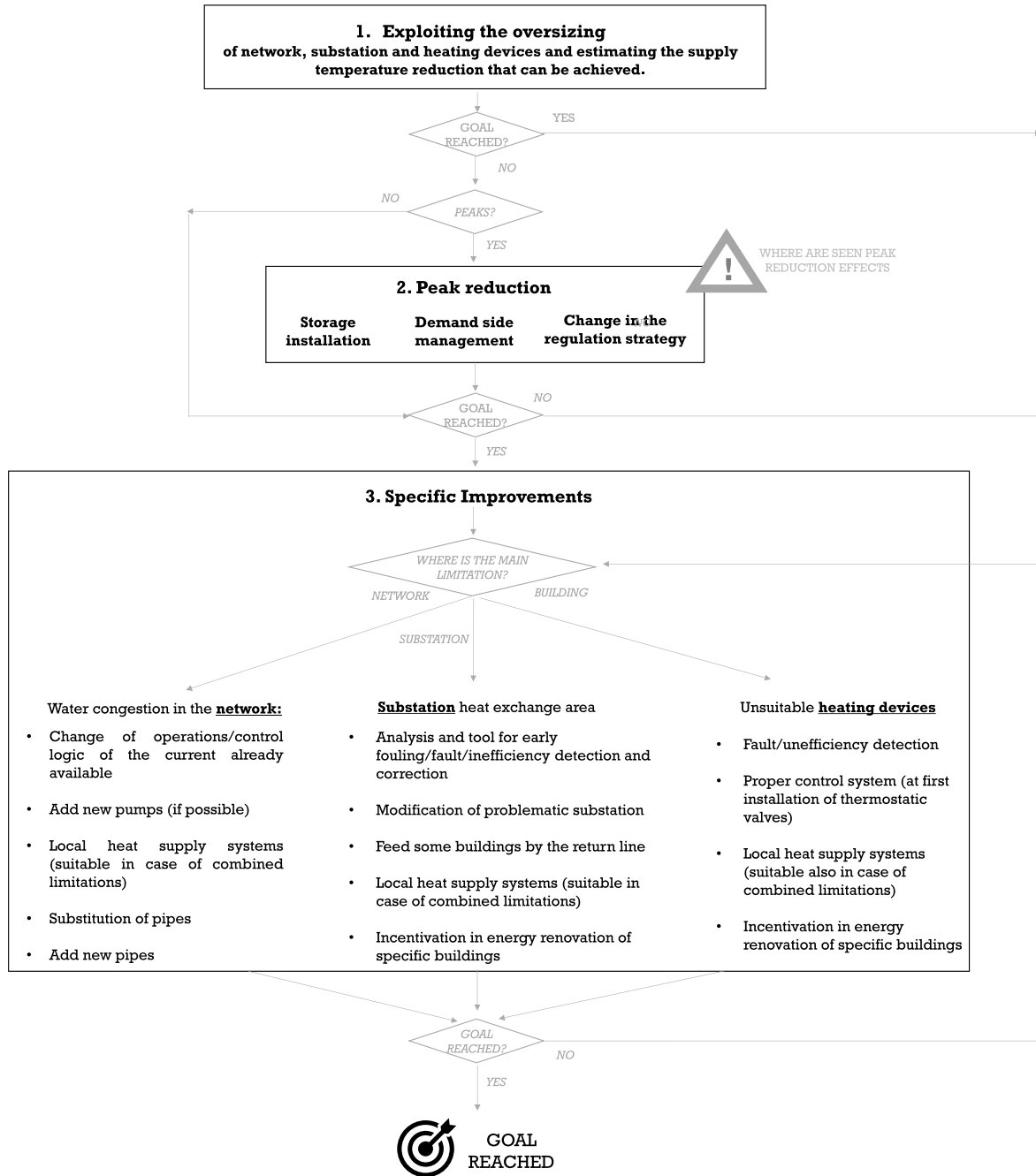

Fig. 10. Workflow for achieving supply temperature reduction in existing DH.

congestion areas All the individual actions cited are deeply discussed in Section 3.1.

- **SUBSTATION:** If the substation heat exchanger limits the supply temperature reduction, at first it is necessary to check the heat exchangers fouling/fault/inefficiencies. After that, it is useful to consider the effects of modifying the most critical substations. In the end, it could be considered the possibility to install additional local heat supply system in a crucial section of the network. All the individual actions cited are discussed in section 3.2

- **BUILDING:** In case the buildings are limiting the supply temperature reduction, the options to be considered are: 1) the fault/inefficiency detection and depending on the outcomes the action on the most limiting radiator 2) thermostatic valves installation and the change of the control strategy 3) the adoption of additional local heat supply. The possible actions cited are discussed in section 3.3.
- d) In case the most suitable modification, in the proper column, is performed and still the supply temperature reduction goal is not met, it is necessary to repeat the loop: to estimate which is the most

limiting part and again act on it. It is possible that, after the modification applied in the step *d*) the second limiting section for the step *e*) is different from that estimated in the step *c*).

- e) Again, after the evaluation of the DH part that limits the supply temperature reduction an action is selected. The loop can be repeated until a satisfactory temperature reduction is achieved.

An alternative option to the supply temperature reduction in the entire network, which is the focus of the current paper, is the adoption of low-temperature sub-networks (LTSN). This can be used when part of the DH is suitable for low supply temperature (e.g. an area of the buildings connected is retrofitted/low consumption) or in case of network expansion. Various examples exist in the literature; an interesting review can be found in Ref. [133] where good practice examples (in Austria, Germany and the Nordic and Baltic countries) are described. In the analysis out of 29 examples are identified (4 meeting the strict definition of LTSN defined in the paper). Among the main existing examples of LTSN are: Albertslund Coopenaghen (Denmark, terraced 560 houses, probably the largest LTDH system in Europe, implemented for existing buildings after refurbishment  $T_{sup} = 57\text{ °C}$ ,  $T_{ret} = 30\text{ °C}$ ) [39, 134], Lystrup (Denmark, network/substation renovated for 7 row houses with totally 41 apartments,  $T_{sup} = 55\text{ °C}$   $T_{ret} = 25\text{ °C}$ ) [135, 136], Adlershof Berlin (Germany,  $T_{sup} = 65\text{ °C}$   $T_{ret} = 40\text{ °C}$ ) [14] and Gluckstein (Germany). Usually, the return water is used as supply for the LTSN. In case the temperature is not sufficient, a portion of hot water from the supply line is mixed. Another option is to use a heat exchanger as done in Västerås [95]. Payback periods of 10–12 years was found, for investment in long distance (20 km) of LTSN with central heat pump. Further information is not provided since the topic is out of the scope of the present work.

### 5.2. Policy and incentivation aspects

Along with a proper procedure for the transition is important to consider a change of perspective. Since reducing the supply temperature is a long-term effort, it is important that all the technical decisions taken related to a network consider the final goal. A main example is that new and substituted devices are compliant with the low supply temperature. For instance, in Aarhus (Denmark), by 2012 obliged design specifications for substations, water heaters and space heating systems newly installed have been set up [16].

In general, it can be stated that the success of the temperature reduction strategy lays combined actions of policy makers and companies. In fact, regulatory constraints related to a) the newly installed devices b) the financial investment/penalties for the end-users depending on the quality of the heat absorbed and the return temperature, are crucial aspects. At the same time, concerning DH operating companies, a successfully path consists in the adoption of proper long-term planning towards ambitious goals that can be reached only if a proper vision is accepted. A successful approach has been adopted in Denmark, through the implementation of a national motivation tariff. This is a bonus or a penalty that is applied to the billing price as a function of the return temperature. In particular the bonus/penalty is 1% of the heating price per degree the average return temperature is respectively below/above a reference temperature [19,137]. Another interesting approach has been implemented in Viborg (Denmark) from 2002, where the DH company has proposed a motivation tariff in form of benefit/penalty as described in Ref. [138]. The motivation tariff adopted is a model, where the average yearly supply temperature is used to calculate the goal for the return temperature. The expense for the motivation tariff is 270 k€/y, the efficiency more than 670k€/y, therefore the gain is 400 k€/y. Viborg DH company also provides assistance and help to costumers with high return temperature to modernise and upgrade their system. This is therefore a win-win situation that can help both costumers and company to save money and costumers to improve comfort. The Viborg experience showed that by introducing smart meters and incentivitation tariffs

the supply temperature was reduced on average from 80 °C to 66 °C (and return from 50 °C to 40 °C); this allowed to exploit heat from an Apple data centre available at 10 km [139]. A further reduction of 5 °C is planned for the next years. Also in Middelfart (Denmark) supply temperatures have been reduced from 81 °C to 63 °C by adopting an optimisation tool by monitoring the operating conditions of the substations and implementing tariff incentives [140].

### 5.3. Research gap

The proposed approach is a possible action plan that can be adopted to analyse how to achieve supply temperature reduction and how to perform it. This has not the ambition of being the best possible cost-benefit approach. The best action flow can be achieved only through a series of optimizations that allow selecting step by step the best action to be applied to the specific DH system. Furthermore, when multiple options are possible, the selection of the best option allows a deep analysis of the specific conditions, preferably relying on proper simulators. Currently literature review for the selection is still unavailable. In the authors knowledge the only attempt has been done in Ref. [43], where a decision making approach has been proposed after workshops with DH operators with the aim of overcoming the problem of bottlenecks and applied to a specific case study. An interesting list of solutions that can be adopted for overcoming issues of supply temperature reduction in buildings, respectively for space heating and domestic hot water, from the cheaper to the most expensive are shown in Ref. [19] (where substation are considered along with heating devices).

Procedures or proper tools to estimate the best set of actions to be implemented for a specific case are still not available. These can be very complex because of many reasons: 1) limitations on buildings, substations and pipes contemporary exist and a global approach could be the best option to be adopted; 2) since problematic buildings, substations and pipes could be in different areas of the city, it is necessary to find a proper approach to provide modification at different levels in the most effective way; 3) the system is large and heterogeneous and significant amount of data are required; 4) model of different devices must be included since various phenomenon should be considered.

## 6. Projects aimed at the reduction of supply temperature in district heating

Various results that have been cited in this paper have been made possible by founding in project context (mainly by IEA and European Community). Indeed, currently and in the last few years, various projects on the transition toward low temperature DH have been proposed and carried out. Some of them are completely devoted to the specific goal. In Table 2, the main existing projects are reported, along with the typology, the duration, the financing institution and the main goals.

*A comprehensive toolbox for integrating low-temperature sub-networks in existing district heating networks* [141] investigates the possibility of integrating of low temperature DH in the return line of an existing large urban DH network. This approach leads to a reduction of the return temperature of the DH improving the system efficiency and allows overcoming problems of mass flow congestions. A project completely related to the transformation of existing DH into low-temperature systems is *Leave 2nd generation behind: cost effective solutions for small-to-large scale DH networks* [142] (pursued by the authors). The aim of the project is to develop cost effective routes for the transition of existing networks into low-temperature system considering the barriers, especially related to the network and substation side. The novelty of the work is to evaluate, with proper tools, to what extent these barriers can be removed. Among the techniques considered are the intervention on specific fluid-dynamic bottlenecks, use of demand-side management and storages, recirculation of mass flow rates, optimal operation of booster pumping station and thermal substation, connection of buildings on the return network, proper supply temperature

setting and optimal modification of the network topology. *CASCADE: LowTEMP Low Temperature District Heating for the Baltic Sea Region* [143] is a European Union (European Regional Development Fund & European Neighbourhood Instrument) funded project in the framework of Interreg Baltic Sea Region Programme 2014–2020. The goal is to promote the adoption of low temperature DH, considering all, new installation, network expansion, renovation of existing networks also in case buildings have not been retrofitted. Interesting results can be found in Ref. [39]. *Stepwise transition strategy and impact assessment for future district heating systems* is a project dealing to transition towards low temperature DH. The experimental analysis performed on 10 real buildings revealed that there is potential already in the existing equipment to reduce heating system operating temperature. This output is very important to enable reduction of supply water in DH. Radiators appear to be often over-dimensioned especially in a trend of global thermal demand reduction, due to building retrofitting measures. In *Transformation roadmap from high to low temperature DH* [144] the possible strategies proposed for the transition towards the 4th generation DH mainly consists in: 1) identifying temperature errors in distribution networks, substations and heating systems in buildings; 2) increasing the thermal lengths in substation heat exchangers; 3) reducing the temperature demand in buildings by reduction of heat demand or increase of the heat transfer surfaces. The project *OPTi-TRANS* aims at enhancing the discussions with the DH companies to assist the transition towards low temperature DH by considering potential actions at technical level (e.g. at building level, new sources, management) and at economic level, including business models and pricing, considering the uncertainly related to the transition. *Towards 4th Generation DH: Experiences with and Potential of Low Temperature DH* aims at providing a roadmap for the transition to sustainable energy and total phase-out of fossil-fuels. This includes the estimation of the benefits in using low temperature DH with a special insight in domestic hot water and the Legionella problem.

Furthermore, there are projects that among the various goals have the temperature reduction of DH networks (despite this is not the main aim). (TEMPO) TEMPerature Optimisation for Low Temperature District Heating across Europe [145,146] aims at developing a) innovations to create low temperature DH for increased network efficiency and integration options for renewable and residual heat sources and b) new business models to boost network competitiveness and attractiveness for stakeholder investment. In the project, 3 different applications are considered: new networks in urban areas, new networks in rural areas, and existing high temperature networks. FLEXYNETS [147] is a H2020 European Project which aims at developing and demonstrating new generation networks working at neutral temperature levels (15–20 °C), through the adoption of reversible heat pumps. RES-DH aims at enhancing the integration of local resources into the existing district heating and cooling networks through future-proof solutions. Among the various issues considered is that the system efficiency can be increased by lowering the network temperatures, which reduce heat losses and favour renewable energies like solar thermal and heat pumps.

Also concerning temperature reduction in DH are the Annex TS1 of IEA-DHC in 2012–2017 “Low Temperature District Heating for Future Energy Systems” [148], Annex X of IEA DHC “Toward 4th Generation District Heating” [91] and Annex TS2 “Implementation of Low-Temperature District Heating Systems” [19]. The Annexes results are reported in the final documents that includes interesting insights on the topic as well as a wide range (in terms of application type) of real DH cases. Among the main concluding remarks are that: a) low temperature DH enhance the integration of renewable and waste energy b) low temperature DH delivered good comfort to the costumers c) often the existing building heating devices are suitable to be operated with lower supply temperature d) further research is required to implement low temperature DH schemes in the various real cases, especially existing.

## 7. Conclusion and future perspectives

The overall conclusion of the review work is that, according to the available scientific literature, there is a large potential for adopting low-temperature DH in existing systems. If space for manoeuvres can be lower in some cases, various options are available to overcome limitations that can occur in the network, substations, and buildings. The main conclusions of the work are:

- The economic and environmental benefits of reducing supply temperature are undisputed. The main are losses reduction and exploitation of low exergy sources like renewable and waste heat. However, the current benefits can be low in case of fossil fuel driven system. The main benefits are the new supply options enabled by the temperature reduction. For this reason, a change of perspective is required to focus on the chances created by the modifications and the significant reduction of the future costs, in order to win the initial resistances. Therefore, the adoption of a long-term planning and an open vision are required to successfully reach the goals.
- In case no modifications are implemented, it is still possible to exploit the fact that some of the components usually result as oversized (often significantly) and the temperature reduction can be implemented at least for a significant fraction of the heating season, and often it can be implemented in the entire network with a reduction of at least 5–10 °C.
- There are several approaches that can be adopted to overcome the limitations met in the reduction. Most of them have been tested through real tests or numerical analysis for the aim of temperature reduction or other aims. A proper combination of them could provide significant results. An action plan is proposed, that can be followed to cost-effectively face the problem.
- Involvement of both companies, and municipalities/policy makers is probable the best way to activate the transition, by adoption of proper incentivisation policies, including regulatory constraints related on new installations and end-user incentives depending on the heat quality and the return temperature level.
- The transition should be done, if possible, in a framework of collaboration between the company and the academics to exploit the knowledge already existing in the DH community. Indeed, several attempts have been done in the literature to: a) improve the heating control systems by adopting new methods to assure low return temperature b) the development of fault/fouling/inefficiency detection tools in substations and building heating systems which, if corrected, can leave large room for manoeuvres in the supply temperature reduction. These attempts should be reported in existing network considering the specific constraint of the considered case.
- It is important that when buildings connected to high/medium temperature DH, energy renovation are done using proper design criteria to enable future connection with low temperature DH.
- The necessity for the company of keeping the focused on the supply temperature reduction in all the decisions, since every action done on the network/substation/building can represent a constraint or differently an opportunity for the future.

The transition rapidity will be dependent on the fuel cost evolution. If, after the strong variation of the last months, costs will abruptly rise, various consequences will occur. The first is that impact of network losses and plant inefficiencies will be more valuable than today. At the same time the adoption of renewable energy technologies will be more convenient. The consequences will probably act as driving forces on the DH companies to fasten the transition. To enhance the transition of the existing network towards low temperature DH, future investigation should include:

- 1) creation of specific methodology to efficiently estimate which are the constraints that mainly limit the temperature reduction in DH.



- 2) develop approaches and models to estimate the best set of actions to be implemented for each type of existing systems, along with the cost required for the action implementation, for enabling supply temperature reduction in a cost-effective manner.

Furthermore, it is important that academic make themselves conveyors of new insights and perspective, showing that benefits of the transition are significant and that there are several cost-effective ways to practically overcome the existing limitations.

### Declaration of competing interest

The authors declare that they have no known competing financial interests or personal relationships that could have appeared to influence the work reported in this paper.

### Data availability

No data was used for the research described in the article.

### Acknowledgment

The analysis here presented has been made possible thanks to funding from IEA DHC (The International Energy Agency Technology Collaboration Programme on District Heating and Cooling). The results are based on the project “Leave 2nd generation behind: cost effective solutions for small-to-large scale DH networks”, financed by IEA DHC within Annex XIII. Project partners are Politecnico di Torino, University of Birmingham and CEA - Commissariat à l'énergie atomique et aux énergies alternatives. For the final results of the project, please visit [www.iea-dhc.org](http://www.iea-dhc.org) after June 2023.

### References

- [1] Lund H, et al. 4th Generation District Heating (4GDH). Integrating smart thermal grids into future sustainable energy systems. *Energy* 2014;68:1–11. <https://doi.org/10.1016/j.energy.2014.02.089>.
- [2] Köfinger M, Basciotti D, Schmidt RR, Meissner E, Doczekal C, Giovannini A. Low temperature district heating in Austria: energetic, ecologic and economic comparison of four case studies. *Energy* 2016;110:95–104. <https://doi.org/10.1016/j.energy.2015.12.103>.
- [3] Lund H, et al. The status of 4th generation district heating: research and results. *Energy* 2018;164:147–59. <https://doi.org/10.1016/j.energy.2018.08.206>.
- [4] Meesenburg W, Ommen T, Thorsen JE, Elmegegaard B. Economic feasibility of ultra-low temperature district heating systems in newly built areas supplied by renewable energy. *Energy* 2020;191. <https://doi.org/10.1016/j.energy.2019.116496>.
- [5] IEA-DHC Annex X - project 3 - website. <https://www.iea-dhc.org/the-research/annexes/2011-2014-annex-x/annex-x-project-03>. [Accessed 12 May 2021]. accessed.
- [6] Rismanchi B. District energy network (DEN), current global status and future development. *Renew Sustain Energy Rev* 2017;75(July 2016):571–9. <https://doi.org/10.1016/j.rser.2016.11.025>.
- [7] Olsthoorn D, Haghighat F, Mirzaei PA. Integration of storage and renewable energy into district heating systems: a review of modelling and optimization. *Sol Energy* 2016. <https://doi.org/10.1016/j.solener.2016.06.054>.
- [8] Lake A, Rezaie B, Beyerlein S. Review of district heating and cooling systems for a sustainable future. *Renew Sustain Energy Rev* 2017;67:417–25. <https://doi.org/10.1016/j.rser.2016.09.061>.
- [9] Yuan M, Zinck Thellufsen J, Sorknaes P, Lund H, Liang Y. District heating in 100% renewable energy systems: combining industrial excess heat and heat pumps. *Energy Convers Manag* 2021;244(18):114527. <https://doi.org/10.1016/j.enconman.2021.114527>.
- [10] Li H, Svendsen S. Energy and exergy analysis of low temperature district heating network. *Energy* 2012;45(1):237–46. <https://doi.org/10.1016/j.energy.2012.03.056>.
- [11] Vivian J, Emmi G, Zarrella A, Jobard X, Pietruschka D, De Carli M. Evaluating the cost of heat for end users in ultra low temperature district heating networks with booster heat pumps. *Energy* 2018;153:788–800. <https://doi.org/10.1016/j.energy.2018.04.081>.
- [12] Buffa S, Cozzini M, D'Antoni M, Baratieri M, Fedrizzi R. 5th generation district heating and cooling systems: a review of existing cases in Europe. *Renew Sustain Energy Rev* 2019;104(December 2018):504–22. <https://doi.org/10.1016/j.rser.2018.12.059>.
- [13] Yang X, Svendsen S. Ultra-low temperature district heating system with central heat pump and local boosters for low-heat-density area: analyses on a real case in Denmark. *Energy* 2018;159:243–51. <https://doi.org/10.1016/j.energy.2018.06.068>.
- [14] Østergaard D, Svendsen S. Space heating with ultra-low-temperature district heating - a case study of four single-family houses from the 1980s. *Energy Proc* 2017;116:226–35. <https://doi.org/10.1016/j.egypro.2017.05.070>.
- [15] Ziemele J, Cilinskis E, Blumberga D. Pathway and restriction in district heating systems development towards 4th generation district heating. *Energy* 2018;152: 108–18. <https://doi.org/10.1016/j.energy.2018.03.122>.
- [16] Kaarup Olsen P, Christiansen CH, Hofmeister M, Svendsen S, Thorsen J-E. Guidelines for low-temperature district heating : a deliverable in the project financially supported by the Danish energy agency in the R&D programme EUDP. *Energiteknologisk Udv. og Demonstr. Progr* 2014;(April):43.
- [17] Manz P, Kermeli K, Persson U, Neuwirth M, Fleiter T, Crijns-graus W. Decarbonizing district heating in EU-27 + UK: how much excess heat is available from industrial sites? *Sustain Times* 2021;13(3):1–31. <https://doi.org/10.3390/su13031439>.
- [18] Benakopoulos T, Salenbien R, Vanhoudt D, Svendsen S. Improved control of radiator heating systems with. *Energies* 2019;12(17).
- [19] Averfalk H, et al. Annex TS2 implementation of low-temperature district heating systems. 2021. p. 201.
- [20] Geyer R, Krail J, Leitner B, Schmidt R-R, Leoni P. Energy-economic assessment of reduced district heating system temperatures. *Smart Energy* 2021;2:100011. <https://doi.org/10.1016/j.segy.2021.100011>.
- [21] Dalla Rosa A, Christensen JE. Low-energy district heating in energy-efficient building areas. *Energy* 2011;36(12):6890–9. <https://doi.org/10.1016/j.energy.2011.10.001>.
- [22] Lund R, Østergaard DS, Yang X, Mathiesen BV. Comparison of low-temperature district heating concepts in a long-term energy system perspective. *Int. J. Sustain. Energy Plan. Manag.* 2017;12:5–18. <https://doi.org/10.5278/ijsepm.2017.12.2>.
- [23] W S, Frederiksen S. District heating and cooling. 2013.
- [24] Li H, Nord N. Transition to the 4th generation district heating - possibilities, bottlenecks, and challenges. *Energy Proc* 2018;149:483–98. <https://doi.org/10.1016/j.egypro.2018.08.213>.
- [25] Rämä M, Sipilä K. Transition to low temperature distribution in existing systems. *Energy Proc* 2017;116:58–68. <https://doi.org/10.1016/j.egypro.2017.05.055>.
- [26] Oyewunmi OA, Kirmse CJW, Pantaleo AM, Markides CN. Performance of working-fluid mixtures in ORC-CHP systems for different heat-demand segments and heat-recovery temperature levels. *Energy Convers Manag* 2017;148:1508–24. <https://doi.org/10.1016/j.enconman.2017.05.078>.
- [27] Flores JFC, Lacarrière B, Chiu JNW, Martin V. Assessing the techno-economic impact of low-temperature subnets in conventional district heating networks. *Energy Proc* 2017;116:260–72. <https://doi.org/10.1016/j.egypro.2017.05.073>.
- [28] Dalla Rosa A, et al. Toward 4 th generation district heating: experience and potential of low-temperature district heating - IEA DHC Annex X report. 2014.
- [29] Arpagaus C, Bless F, Uhlmann M, Schiffmann J, Bertsch SS. High temperature heat pumps: market overview, state of the art, research status, refrigerants, and application potentials. *Energy* 2018;152:985–1010, Jun. <https://doi.org/10.1016/j.energy.2018.03.166>.
- [30] Wahlroos M, Pärssinen M, Manner J, Syri S. Utilizing data center waste heat in district heating – impacts on energy efficiency and prospects for low-temperature district heating networks. *Energy* 2017;140(2017):1228–38. <https://doi.org/10.1016/j.energy.2017.08.078>.
- [31] Averfalk H, Werner S. Efficient heat distribution in solar district heating systems. 2018 [Online]. Available: <https://hh.diva-portal.org/smash/get/diva2:1204231/FULLTEXT01.pdf>.
- [32] Averfalk H, Werner S. Economic benefits of fourth generation district heating. *Energy* 2020;193:116727. <https://doi.org/10.1016/j.energy.2019.116727>.
- [33] H. S. A. Müller, R. Heimrath, P. Leoni, “How much to invest? Balancing investment costs and economic benefits of reducing the temperature levels in existing district heating networks.”.
- [34] Li H, et al. Future low temperature district heating design guidebook - final report of IEA DHC Annex TS1. Technology Collaboration Programme by IEA; 2017.
- [35] Schmidt D. Low temperature district heating for future energy systems, vol. 149; 2018.
- [36] Li H, Wang SJ. Challenges in smart low-T emperature district heating development. *Energy Proc* 2014;61:1472–5. <https://doi.org/10.1016/j.egypro.2014.12.150>.
- [37] Østergaard DS, Svendsen S. Experience from a practical test of low-temperature district heating for space heating in five Danish single-family houses from the 1930s. *Energy* 2018;159:569–78. <https://doi.org/10.1016/j.energy.2018.06.142>.
- [38] Nord N, Love Nielsen EK, Kauko H, Tereshchenko T. Challenges and potentials for low-temperature district heating implementation in Norway. *Energy* 2018;151: 889–902. <https://doi.org/10.1016/j.energy.2018.03.094>.
- [39] Cenian A, Dzierzowski M, Pietrzykowski B. On the road to low temperature district heating. *J. Phys. Conf. Ser.* 2019;1398(1). <https://doi.org/10.1088/1742-6596/1398/1/012002>.
- [40] Schmidt D, et al. Low temperature district heating for future energy systems. *Energy Proc* 2017;116:26–38. <https://doi.org/10.1016/j.egypro.2017.05.052>.
- [41] H. İ. Topal, H. İ. Tol, M. Kopaç, and A. Arabkoohsar, “Energy, exergy and economic investigation of operating temperature impacts on district heating systems: transition from high to low-temperature networks,” *Energy*, vol. 251, 2022, doi: 10.1016/j.energy.2022.123845.
- [42] Brange L, Englund J, Serhned K, Thern M, Lauenburg P. Bottlenecks in district heating systems and how to address them. *Energy Proc* 2017;116:249–59. <https://doi.org/10.1016/j.egypro.2017.05.072>.

- [43] Brange L, Sernhed K, Thern M. Decision-making process for addressing bottleneck problems in district heating networks, vol. 20; 2019. p. 37–50.
- [44] Guelpa E, Mutani G, Todeschi V, Verda V. Reduction of CO2 emissions in urban areas through optimal expansion of existing district heating networks. *J Clean Prod* 2018;204:117–29. <https://doi.org/10.1016/j.jclepro.2018.08.272>.
- [45] Brange L, Lauenburg P, Sernhed K, Thern M. Bottlenecks in district heating networks and how to eliminate them – a simulation and cost study. *Energy* 2017; 137:607–16. <https://doi.org/10.1016/j.energy.2017.04.097>.
- [46] NetSim website. <https://www.vitescsoftware.com/en/product-areas/energy/products/netsim-grid-simulation/>.
- [47] <https://www.imp.gda.pl/lowtemp/conference/lectures/Lomza.pdf>.
- [48] Peng Y, Wenju H, Deying L, Xiaoyu L, Xiping Z. Application and economic analysis of water jet pump in new district heating system. *Procedia Eng* 2017;205: 996–1003. <https://doi.org/10.1016/j.proeng.2017.10.158>.
- [49] Gong E, Wang N, You S, Wang Y, Zhang H, Wei S. Optimal operation of novel hybrid district heating system driven by central and distributed variable speed pumps. *Energy Convers Manag* 2019;196(June):211–26. <https://doi.org/10.1016/j.enconman.2019.06.004>.
- [50] Wang N, et al. Hydraulic resistance identification and optimal pressure control of district heating network. *Energy Build* 2018;170:83–94. <https://doi.org/10.1016/j.enbuild.2018.04.003>.
- [51] Bastida H, Ugalde-Loo CE, Abysekera M, Qadrdan M. Modelling and control of district heating networks with reduced pump utilisation. *IET Energy Syst. Integr.* 2021;3(1):13–25. <https://doi.org/10.1049/esi2.12001>.
- [52] Guelpa E, Toro C, Sciacovelli A, Melli R, Sciubba E, Verda V. Optimal operation of large district heating networks through fast fluid-dynamic simulation. *Energy* 2016;102. <https://doi.org/10.1016/j.energy.2016.02.058>.
- [53] Guelpa E, Verda V. Model for optimal malfunction management in extended district heating networks. *Appl Energy* 2018;230(April):519–30. <https://doi.org/10.1016/j.apenergy.2018.08.024>.
- [54] Sciacovelli A, Verda V. Topology optimization of robust district heating networks, vol. 140; 2018. p. 1–9. <https://doi.org/10.1115/1.4038312>. February.
- [55] Egberts P, Tümer C, Loh K, Octaviano R. Challenges in heat network design optimization. *Energy* 2020;203:117688. <https://doi.org/10.1016/j.energy.2020.117688>.
- [56] Jamssek M, Dobersek D, Goricanec D, Kroppe J. Determination of Optimal District Heating Pipe Network Configuration 2010;5(3):165–74.
- [57] Kalinci Y, Hepbasli A, Tavman I. Determination of optimum pipe diameter along with energetic and exergetic evaluation of geothermal district heating systems. *Model. Appl* 2008;40:742–55. <https://doi.org/10.1016/j.enbuild.2007.05.009>.
- [58] Olsen PK. International guidelines for low-temperature district heating. 2014. <https://www.imp.gda.pl/lowtemp/conference/lectures/Wprowadzenie.pdf>.
- [59] Fabre A, Thomas R, Duplessis B, Tran C, Stabat P. Dynamic modeling for evaluation of triple-pipe configuration potential in geothermal district heating networks. *Energy Convers Manag* 2018;173(February):461–9. <https://doi.org/10.1016/j.enconman.2018.07.087>.
- [60] Xu Q, et al. A new type of two-supply, one-return, triple pipe-structured heat loss model based on a low temperature district heating system. *Energy* 2021;218: 119569. <https://doi.org/10.1016/j.energy.2020.119569>.
- [61] Guelpa E, Sciacovelli A, Verda V. Thermo-fluid dynamic model of large district heating networks for the analysis of primary energy savings. *Energy* 2019;184: 34–44. <https://doi.org/10.1016/j.energy.2017.07.177>.
- [62] Giraud L, Bavière R, Paulus C, Vallée M, Robin J-F. Dynamic modelling, experimental validation and simulation of a virtual district heating network. In: 28th int. Conf. Effic. Cost. optim. Simul. Environ. Impact energy syst.; 2015. p. 2845–56.
- [63] Guelpa E, Capone M, Verda V. The challenge of reducing supply temperature in existing district heating networks. 2021.
- [64] Brand M, Svendsen S. Renewable-based low-temperature district heating for existing buildings in various stages of refurbishment. *Energy* 2013;62:311–9. <https://doi.org/10.1016/j.energy.2013.09.027>.
- [65] Wang Q, Plošić A, Holmberg S. Retrofitting with low-temperature heating to achieve energy-demand savings and thermal comfort. *Energy Build* 2015;109: 217–29. <https://doi.org/10.1016/j.enbuild.2015.09.047>.
- [66] Sarbu I, Valea ES. Energy savings potential for pumping water in district heating stations. 2015. p. 5705–19. <https://doi.org/10.3390/su7055705>.
- [67] Vesterlund M, Toffolo A. Applied sciences design optimization of a district heating network expansion. a Case Study for the Town of Kiruna; 2017. <https://doi.org/10.3390/app7050488>.
- [68] Guelpa E, Verda V. Thermal energy storage in district heating and cooling systems: a review. *Appl Energy* 2019;252. <https://doi.org/10.1016/j.apenergy.2019.113474>.
- [69] Brand L, Calvén A, Englund J, Landersjö H, Lauenburg P. Smart district heating networks – a simulation study of prosumers' impact on technical parameters in distribution networks. *Appl Energy* 2014;129:39–48. <https://doi.org/10.1016/j.apenergy.2014.04.079>.
- [70] Guelpa E, Verda V. Demand response and other demand side management techniques for district heating : a review. *Energy* 2021;219:119440. <https://doi.org/10.1016/j.energy.2020.119440>.
- [71] Britz R. Evaluation of sensors for monitoring temperatures in district heating pipes. 2016. p. 5.
- [72] E. Guelpa and V. Verda, "Automatic fouling detection in district heating substations: methodology and tests," *Appl Energy*, vol. 258, 2020, doi: 10.1016/j.apenergy.2019.114059.
- [73] Kim R, Hong Y, Choi Y, Yoon S. System-level fouling detection of district heating substations using virtual-sensor-assisted building automation system. *Energy* 2021;227:120515. <https://doi.org/10.1016/j.energy.2021.120515>.
- [74] Babak T. Improvement of the heat substitution design for district heating supply systems, vol. 1. Springer International Publishing; 2020.
- [75] Volkova A, Krupenski I, Ledvanov A, Hlebnikov A. Energy cascade connection of a low-temperature district heating network to the return line of a high-temperature district heating network, vol. 198; 2020. <https://doi.org/10.1016/j.energy.2020.117304>.
- [76] Østergaard DS. Heating of existing buildings by low-temperature district heating. Technical University of Denmark, Department of Civil Engineering; 2018.
- [77] Tunzi M, Østergaard DS, Svendsen S, Boukhanouf R, Cooper E. Method to investigate and plan the application of low temperature district heating to existing hydraulic radiator systems in existing buildings. *Energy* 2016;113: 413–21. <https://doi.org/10.1016/j.energy.2016.07.033>.
- [78] Somogyi V, Sebestyén V, Domokos E. Assessment of wastewater heat potential for district heating in Hungary. *Energy* 2018;163:712–21. <https://doi.org/10.1016/j.energy.2018.07.157>.
- [79] Gadd H. To analyse measurements is to know! Lund University; 2014.
- [80] Aminian J SS. Evaluation of ANN modeling for prediction of crude oil fouling behavior. *Appl. Therm. Eng. Therm Eng.* 2008;28:668–74.
- [81] Müller-Steinhagen H, Malayeri MR, Watkinson AP. Heat exchanger fouling: mitigation and cleaning strategies. *Heat Transf. Eng.* 2011;32(3–4).
- [82] Mohanty DK, Singru PM. Use of C-factor for monitoring of fouling in a shell and tube heat exchanger. *Energy* 2011;36(5):2899–904. <https://doi.org/10.1016/j.energy.2011.02.032>.
- [83] P. D. Genić Sb, Jačimović BM, Mandić D, "Experimental determination of fouling factor on plate heat exchangers in district heating system,," *Energy Build.*, vol. 50, no. 204–211.
- [84] Zinko M, H, Hoon L, Bong-Kyun K, Youn-Hong K, Lindkvist H, Loewen A, Seungkyu H, Walleetun H, Wigbels. Improvement of operational temperature differences in district heating systems. 2005.
- [85] Köfing M, Basciotti D, Schmidt RR. Reduction of return temperatures in urban district heating systems by the implementation of energy-cascades. *Energy Proc* 2017;116:438–51. <https://doi.org/10.1016/j.egypro.2017.05.091>.
- [86] Gadd H, Werner S. Fault detection in district heating substations. *Appl Energy* 2015;157:51–9. <https://doi.org/10.1016/j.apenergy.2015.07.061>.
- [87] Zimmerman N, Dahlquist E, Kyprianidis K. Towards on-line fault detection and diagnostics in district heating systems. *Energy Proc* 2017;105:1960–6. <https://doi.org/10.1016/j.egypro.2017.03.567>.
- [88] Mauthner F, Herkel S. Technical report substak C – Part C1 IEA SHC task 52, vol. 2017; 2016. p. 1–31. no. January.
- [89] [https://thermafex.greenenergylab.at/e4a\\_demonstrator/demo-4/](https://thermafex.greenenergylab.at/e4a_demonstrator/demo-4/).
- [90] Li H, et al. Annex X final report toward 4 th generation district heating : experience and potential of low-temperature district heating. IEA Annex X; 2014. p. 205 [Online]. Available: <http://www.iea-dhc.org/the-research/annexes/2011-2014-annex-x/annex-x-project-03.html>.
- [91] Brand M, Thorsen JE, Svendsen S, Christiansen CH. A direct Heat Exchanger Unit used for domestic hot water supply in a single-family house supplied by Low Energy District Heating. In: 12th international symposium on district heating and cooling; 2010. p. 60–8.
- [92] Yang X, Li H, Svendsen S. Energy, economy and exergy evaluations of the solutions for supplying domestic hot water from low-temperature district heating in Denmark. *Energy Convers Manag* 2016;122:142–52. <https://doi.org/10.1016/j.enconman.2016.05.057>.
- [93] Yang X, Li H, Svendsen S. Alternative solutions for inhibiting Legionella in domestic hot water systems based on low-temperature district heating. *Build Serv Eng Technol* 2016;37(4):468–78. <https://doi.org/10.1177/0143624415613945>.
- [94] <https://celciuscity.eu/case-studies-low-temperature-district-heating-systems/>.
- [95] Elmegaard B, Schmidt T, Markussen M, Iversen J. Integration of space heating and hot water supply in low temperature district heating. *Energy Build* 2016;124: 255–64. <https://doi.org/10.1016/j.enbuild.2015.09.003>.
- [96] Benakopoulos T, Tunzi M, Salenbien R, Svendsen S. Strategy for low-temperature operation of radiator systems using data from existing digital heat cost allocators. *Energy* 2021;231:120928. <https://doi.org/10.1016/j.energy.2021.120928>.
- [97] Østergaard DS, Svendsen S. Theoretical overview of heating power and necessary heating supply temperatures in typical Danish single-family houses from the 1900s. *Energy Build* 2016;126:375–83. <https://doi.org/10.1016/j.enbuild.2016.05.034>.
- [98] Svendsen S. Effects of boosting the supply temperature on pipe dimensions of low-energy district heating networks : a case study in Gladsaxe , Denmark, vol. 88; 2015. p. 324–34. <https://doi.org/10.1016/j.enbuild.2014.10.067>.
- [99] Ljunggren P, Wollerstrand J. Optimum performance of radiator space heating systems connected to achieve lowest possible district heating return temperature. In: 10th Int. Symp. Dist. Heat. Cool., no. September; 2006. p. 10 [Online]. Available: <http://www.lsta.it/files/events/ljunggren.pdf>.
- [100] Jangsten M, Kensby J, Dalenbäck JO, Trüschel A. Survey of radiator temperatures in buildings supplied by district heating. *Energy* 2017;137:292–301. <https://doi.org/10.1016/j.energy.2017.07.017>.
- [101] Østergaard DS, Svendsen S. Costs and benefits of preparing existing Danish buildings for low-temperature district heating. *Energy* 2019;176:718–27. <https://doi.org/10.1016/j.energy.2019.03.186>.
- [102] <https://facilities.ok.ubc.ca/geoexchange/des-operation/>.
- [103] <https://sites.ontariotechu.ca/gogreen/initiatives/on-campus/energy.php>.
- [104] <https://www.ethz.ch/en/the-eth-zurich/sustainability/campus/environment/energy/energy-grid.html>.
- [105]



- [106] Dzierzgowski M. Verification and improving the heat transfer model in radiators in the wide change operating parameters. *Energies* 2021;14(20). <https://doi.org/10.3390/en14206543>.
- [107] Siano P. Demand response and smart grids - a survey. *Renew Sustain Energy Rev* 2014;30:461–78. <https://doi.org/10.1016/j.rser.2013.10.022>.
- [108] Gelazanskas L, Gamage KAA. Demand side management in smart grid: a review and proposals for future direction. *Sustain Cities Soc* 2014;11:22–30. <https://doi.org/10.1016/j.scs.2013.11.001>.
- [109] Aoun N, Arousseau A, Sandou G. Load shifting of space-heating demand in DHSs based on a building model identifiable at substation level Context Space-heating demand management. November 2018:13–4.
- [110] Monsalvete Álvarez de Urbarrí P, Eicker U, Robinson D. Energy performance of decentralized solar thermal feed-in to district heating networks. *Energy Proc* 2017;116:285–96. <https://doi.org/10.1016/j.egypro.2017.05.075>.
- [111] Guelpa E, Barbero G, Sciacovelli A, Verda V. Peak-shaving in district heating systems through optimal management of the thermal request of buildings. *Energy* 2017;137. <https://doi.org/10.1016/j.energy.2017.06.107>.
- [112] Goy S, Ashouri A, Maréchal F, Finn D. Estimating the potential for thermal load management in buildings at a large scale: overcoming challenges towards a replicable methodology. *Energy Proc* 2017;111(September 2016):740–9. <https://doi.org/10.1016/j.egypro.2017.03.236>.
- [113] Li H, Wang SJ. Load management in district heating operation. *Energy Proc* 2015; 75:1202–7. <https://doi.org/10.1016/j.egypro.2015.07.155>.
- [114] Basciotti RR, D, Köfinger M, Marguerite C, Terreros O, Agugiario G, Schmidt. Methodology for the assessment of temperature reduction potentials in district heating networks by demand side measures and cascading solutions. In: 12th REHVA world congress CLIMA; 2016. p. 10.
- [115] Kärkkäinen S, Sipilä K, Pirvola L, Esterinen J, Eriksson E, Soikkeli S. Demand side management of the district heating systems. 2003. p. 104 [Online]. Available: <http://www.vtt.fi/inf/pdf/>.
- [116] Guelpa E, et al. Demand side management in district heating networks: a real application. *Energy* 2019;182. <https://doi.org/10.1016/j.energy.2019.05.131>.
- [117] Djuri D. Classification of measures for dealing with district heating load variations — a systematic review. 2021.
- [118] Mishra AK, et al. Demand response events in district heating: results from field tests in a university building. *Sustain Cities Soc* 2019;47(February):101481. <https://doi.org/10.1016/j.scs.2019.101481>.
- [119] Guelpa E, Marincioni L. Demand side management in district heating systems by innovative control. *Energy* 2019;188. <https://doi.org/10.1016/j.energy.2019.116037>.
- [120] Kensby J, Trüschel A, Dalenbäck JO. Potential of residential buildings as thermal energy storage in district heating systems - results from a pilot test. *Appl Energy* 2015;137:773–81. <https://doi.org/10.1016/j.apenergy.2014.07.026>.
- [121] Sweetnam T, Spataru C, Barrett M, Carter E. Domestic demand-side response on district heating networks. *Build Res Inf* 2019;47(4):330–43. <https://doi.org/10.1080/09613218.2018.1426314>.
- [122] Aoun N, Bavière R, Vallée M, Arousseau A, Sandou G. Modelling and flexible predictive control of buildings space-heating demand in district heating systems. *Energy* 2019;188. <https://doi.org/10.1016/j.energy.2019.116042>.
- [123] Aoun N, Bavière R, Vallée M, Brun A, Sandou G. Dynamic simulation of residential buildings supporting the development of flexible control in district heating systems. In: Proc. 13th int. Model. Conf. Regensburg, ger. March 4–6, 2019. vol. 157; 2019. p. 129–38. <https://doi.org/10.3384/ecp19157129>.
- [124] Frayssinet L, Merlier L, Kuznik F, Hubert JL, Milliez M, Roux JJ. Modeling the heating and cooling energy demand of urban buildings at city scale. *Renew Sustain Energy Rev* 2018;81(June 2017):2318–27. <https://doi.org/10.1016/j.rser.2017.06.040>.
- [125] Saletti C, Zimmerman N, Morini M, Kyprianidis K, Gambarotta A. Enabling smart control by optimally managing the State of Charge of district heating networks. *Appl Energy* 2021;283(July 2020):116286. <https://doi.org/10.1016/j.apenergy.2020.116286>.
- [126] Wang D, Carmeliet J, Orehounig K. Design and assessment of district heating systems with solar thermal prosumers and thermal storage. 2021. p. 1–27.
- [127] Mbayer M, Abunku, Wim JC. Modelling of a CHP system with electrical and thermal storage. 2015.
- [128] Nuytten T, Claessens B, Paredis K, Van Bael J, Six D. Flexibility of a combined heat and power system with thermal energy storage for district heating. *Appl Energy* 2013;104:583–91. <https://doi.org/10.1016/j.apenergy.2012.11.029>.
- [129] Ommen T, Markussen WB, Elmegaard B. Heat pumps in combined heat and power systems. *Energy* 2014;76:989–1000. <https://doi.org/10.1016/j.energy.2014.09.016>.
- [130] Postnikov I, Fournier J, Lacarrière B, Le Corre O. Prosumer in the district heating systems : operating and reliability modeling operating and reliability modeling assessing the feasibility of using the heat demand-outdoor postnikov for temperature function a district demand forecast prosumer in the distr. *Energy Proc* 2019;158:2530–5. <https://doi.org/10.1016/j.egypro.2019.01.411>.
- [131] Ancona MA, et al. In fl uence of the prosumer allocation and heat production on a district heating network, vol. 7; 2021. p. 1–11. <https://doi.org/10.3389/fmech.2021.623932>. April.
- [132] Pipiciello M, Caldera M, Cozzini M, Ancona MA, Melino F, Di B. Experimental characterization of a prototype of bidirectional substation for district heating with thermal prosumers. *Energy* 2021;223:120036. <https://doi.org/10.1016/j.energy.2021.120036>.
- [133] Puschnigg S, Jauschnik G, Moser S, Volkova A, Linhart M. A review of low-temperature sub-networks in existing district heating networks: examples, conditions, replicability. *Energy Rep* 2021;7:18–26. <https://doi.org/10.1016/j.egypr.2021.09.044>.
- [134] [https://www.imp.gda.pl/ee\\_cities/prezentacje/pierwszy/2\\_Christian\\_Oxenvad.pdf](https://www.imp.gda.pl/ee_cities/prezentacje/pierwszy/2_Christian_Oxenvad.pdf).
- [135] Thorsen JE, Christiansen CH, Brand M, Olesen PK, Larsen CT. Experiences on low-temperature district heating in Lystrup - Denmark. *Proc. Int. Conf. Dist. Energy* 2011:(pp. 1-10).
- [136] Ringården Boligforening. Very-low-temperature district heating for low- energy buildings in small communities showcase larch garden II , Lystrup , Denmark district energy awards 2011 : very-low-temperature district heating for low-energy buildings - small community larch garden I. *Int Dist Energy Clim Award* 2011.
- [137] Benakopoulos T, Vergo W, Tunzi M, Salenbien R, Kolarik J, Svendsen S. Energy and cost savings with continuous low temperature heating versus intermittent heating of an office building with district heating. *Energy* 2022;252:124071. <https://doi.org/10.1016/j.energy.2022.124071>.
- [138] Tom Diget. Motivation tariff – the key to a low temperature district heating network - hot cool, international magazine on district heating and cooling. 2019.
- [139] Abildgaard M. Data centers and 4GDH in practice - the case of Viborg. In: Paper presented at the 3rd international conference on smart energy systems and 4th generation district heating, 12-13 september, copenhagen; 2017. [https://www.4dh.eu/images/VF\\_-\\_Data\\_Centers\\_and\\_4](https://www.4dh.eu/images/VF_-_Data_Centers_and_4).
- [140] Schmidt A, Dietrich. Kallert, *Low temperature district heating for future energy systems, Final report*. IEA DHC Annex TS1; 2016.
- [141] IEA-DHC Annex XIII- project 7 - website. <https://www.iea-dhc.org/the-research/annexes/annex-xiii/annex-xiii-project-07>. [Accessed 16 May 2021]. accessed.
- [142] IEA-DHC Annex XIII - project 1 - website. <https://www.iea-dhc.org/the-research/annexes/annex-xiii/annex-xiii-project-01>. [Accessed 12 May 2021]. accessed.
- [143] <https://www.lowtemp.eu/#:~:text=The%20project%20E2%80%9CLOW%20Temperature%20District%20Heating%20for%20the,installation%20of%20so-called%204th%20generation%20district%20heating%20networks>.
- [144] IEA-DHC Annex XI- project 1- website. <https://www.iea-dhc.org/the-research/annexes/2014-2017-annex-xi/annex-xi-project-01>. [Accessed 19 May 2021]. accessed.
- [145] TEMPO project website. <http://www.tempo-dhc.eu/>. [Accessed 16 June 2021]. accessed.
- [146] TEMPO Projct - EC wbsite. <https://cordis.europa.eu/project/id/768936/it>. [Accessed 17 May 2021]. accessed.
- [147] Flexynets website. <http://www.flexynets.eu/en/>. [Accessed 30 May 2021]. accessed.
- [148] Schmidt D, Kallert A. International energy agency technology collaboration Program on district heating and cooling including combined heat and power ANNEX TS1 low temperature district heating for future energy systems FUTURE LOW TEMPERATURE DISTRICT HEATING DESIGN GUIDEBOOK. 2019.
- [149] IEA-DHC Annex XII - project 4 - website. <https://www.iea-dhc.org/the-research/annexes/annex-xii/annex-xii-project-04>. [Accessed 12 May 2021]. accessed.
- [150] IEA-DHC Annex XIII - project 5 - website. <https://www.iea-dhc.org/the-research/annexes/annex-xiii/annex-xiii-project-05>. [Accessed 12 May 2021]. accessed.
- [151] RES DHC Project website. <https://www.res-dhc.com/it/>. [Accessed 12 June 2021]. accessed.
- [152] RES-DHC Project EC website. <https://cordis.europa.eu/project/id/952873/it>. [Accessed 12 June 2021]. accessed.
- [153] Markussen JE, Michael, Elmegaard Brian, Ommen Torben Schmidt, Brand Marek, Thorsen. Heat pumps for domestic hot water preparation in connection with low temperature district heating. 2013.