

6-30-1972

Computer simulation of a Linde "double column"

John A. Bazan
New Jersey Institute of Technology

Follow this and additional works at: <https://digitalcommons.njit.edu/theses>



Part of the [Chemical Engineering Commons](#)

Recommended Citation

Bazan, John A., "Computer simulation of a Linde "double column"" (1972). *Theses*. 2036.
<https://digitalcommons.njit.edu/theses/2036>

This Thesis is brought to you for free and open access by the Electronic Theses and Dissertations at Digital Commons @ NJIT. It has been accepted for inclusion in Theses by an authorized administrator of Digital Commons @ NJIT. For more information, please contact digitalcommons@njit.edu.

Copyright Warning & Restrictions

The copyright law of the United States (Title 17, United States Code) governs the making of photocopies or other reproductions of copyrighted material.

Under certain conditions specified in the law, libraries and archives are authorized to furnish a photocopy or other reproduction. One of these specified conditions is that the photocopy or reproduction is not to be “used for any purpose other than private study, scholarship, or research.” If a user makes a request for, or later uses, a photocopy or reproduction for purposes in excess of “fair use” that user may be liable for copyright infringement,

This institution reserves the right to refuse to accept a copying order if, in its judgment, fulfillment of the order would involve violation of copyright law.

Please Note: The author retains the copyright while the New Jersey Institute of Technology reserves the right to distribute this thesis or dissertation

Printing note: If you do not wish to print this page, then select “Pages from: first page # to: last page #” on the print dialog screen

The Van Houten library has removed some of the personal information and all signatures from the approval page and biographical sketches of theses and dissertations in order to protect the identity of NJIT graduates and faculty.

ABSTRACT

LINDE "DOUBLE COLUMN" SIMULATION by John A. Bazan

June, 1972

The purpose of this thesis is to develop a Fortran Computer Program to simulate the operation of a Linde "Double Column" for the separation of air into oxygen and nitrogen. The model outputs the number of contact stages required, the reflux ratio, the heat loads (condenser and reboiler, and the five profiles of temperature, pressure, vapor flow rate, liquid flow rate, and light component composition. From this data, the proposed design can be evaluated, and the effect of varying operating conditions explored.

APPROVAL OF THESIS
COMPUTER SIMULATION OF A
LINDE "DOUBLE COLUMN"

by
John A. Bazan
FOR

DEPARTMENT OF CHEMICAL ENGINEERING
NEWARK COLLEGE OF ENGINEERING
BY
FACULTY COMMITTEE

APPROVED:

NEWARK, NEW JERSEY

JUNE, 1972

COMPUTER SIMULATION OF A
LINDE "DOUBLE COLUMN"

by ..

John A. Bazan

A THESIS PRESENTED IN PARTIAL FULFILLMENT
OF
THE REQUIREMENTS FOR THE DEGREE
OF
MASTER OF SCIENCE IN CHEMICAL ENGINEERING
AT
NEWARK COLLEGE OF ENGINEERING

This thesis is to be used only with due regard to the rights of the author. Bibliographical references may be noted, but passages must not be copied without permission of the College and without credit being given in subsequent written or published work.

NEWARK, NEW JERSEY

1972

ACKNOWLEDGMENTS

The author wishes to express his appreciation to Dr. Edward C. Roche, Jr. for his advice and assistance in the completion of this thesis.

TABLE OF CONTENTS

<u>CHAPTER</u>	<u>SUBJECT</u>	<u>PAGE</u>
I	Theory Behind the "Double Column"	1
II	Approach and Methods Used in Developing the Model	13
III	Convergence Problem	36
IV	Example Problems	40
	A. Example No. 1	41
	B. Example No. 2	102
	C. Example No. 3	113
	Appendix A	
	Input Data Sheet	131
	Appendix B	
	Program Listing	135
	Bibliography	168

LIST OF ILLUSTRATIONS

<u>FIGURE</u>		<u>PAGE</u>
1.	Simple Linde Air Column	3
2.	Linde "Double Column"-Stage I	7
3.	Linde "Double Column"-Stage II	11
4.	Linde "Double Column"-Complete	12
5.	Condenser and First Contact Stage-Top Down Calculations	21
6.	Rectifying Section-Top Down Calculational Sequence	23
7.	Feed Zone-Top Down Calculational Sequence	25
8.	Stripping Section-Top Down Calculational Sequence	27
9.	Stripping Section-Bottom Up Calculational Sequence	29
10.	Representation of "Double Column" on (h,x) Diagram	38

CHAPTER I

THEORY BEHIND THE "DOUBLE COLUMN"

Air separation is an important commercial enterprise in today's world. From production as a laboratory curiosity in the late nineteenth century, the production of oxygen and nitrogen rose in 1966 to 256 and 91 billion standard cubic feet respectively.¹ Predominant among separation techniques employed is fractional distillation utilizing the Linde "Double Column" first developed by Carl Linde in 1910. Actually consisting of a distillation column surmounted by a dual feed reboiled absorber, the "Double Column" when combined with a Joule-Thompson cycle is essential for the high purity separation of air's bulk constituents; oxygen, nitrogen and argon. Therefore, the purpose of this thesis project is to present a mathematical model to simulate the operation of the "Double Column" for design purposes. To understand how the model works, however, it is necessary to describe the evolution of the "Double Column" design. For clarity, air will be treated as a binary mixture of oxygen and nitrogen in this discussion.

1. Simpson, C.H., Chemicals from the Atmosphere, New York: Doubleday, Inc., 1969, p.136.

The first major use for pure oxygen occurred in 1895 when Henri Louis Le Chatelier demonstrated the oxyacetylene flame's cutting and welding abilities. The steel industry, which remains today the largest user of oxygen, began with the introduction of this essential tool. As the demand increased for larger and larger amounts of oxygen, a commercially feasible means of supply had to be developed. To this end, Carl Linde began operation of his simplest cycle for air separation in 1902.² This simple cycle, illustrated in Figure 1, consists of a heat exchanger, a stripping column and an expansion valve. Clean, dry, carbon dioxide free air is compressed to between 30 and 200 atmospheres, and introduced into the heat exchanger at point B', where it is cooled by the returning cold products at A and D. After passing through the sump coil at E, the compressed air is expanded isenthalpically in the expansion valve, V, to atmospheric pressure. The resulting stream, mostly liquid, enters the top of the stripper at point L. As the liquid descends it becomes oxygen enriched until it is finally evaporated by thermal contact with the compressed air in the coil, E. At steady state, pure oxygen is withdrawn at A and impure nitrogen, containing approximately seven to ten percent oxygen, is withdrawn at D. If both products are

2. Ruhemann, M., The Separation of Gases, Second Edition, London: Oxford University Press, 1952, p.141.

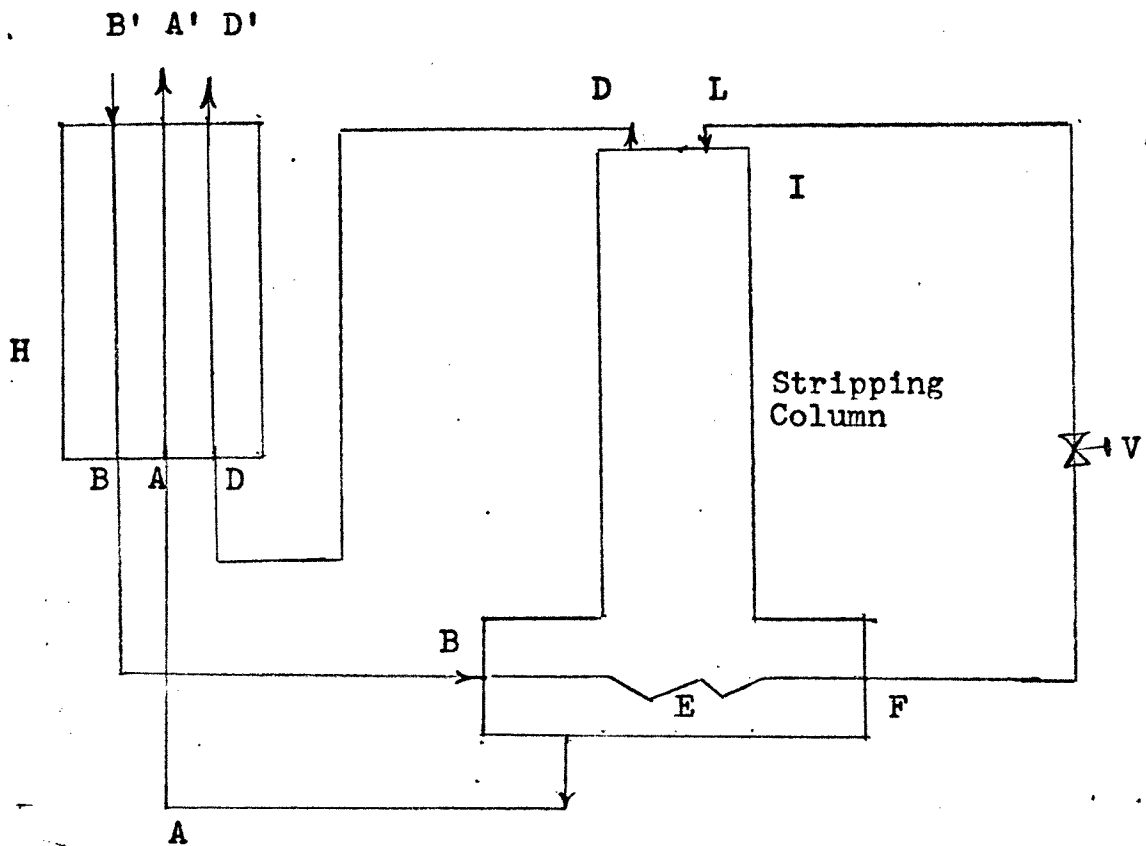

FIGURE 1

- H = The heat exchanger
- V = The expansion valve
- B', B = Inlet feed air
- A', A = Oxygen product
- D', D = Nitrogen product
- E = Evaporator

to be gaseous, both product streams return through the heat exchanger precooling the incoming air. If, however, a liquid oxygen product is desired, only the nitrogen is used to cool the feed air. To compensate for the loss of the refrigeration provided by the returning liquid oxygen stream, the entering air must now be compressed to a higher pressure since the incoming air must be cooled to the same temperature as when both returning products are used for cooling. It is essential that the entering air be dry and free of carbon dioxide because at the extremely low temperatures used, the water and carbon dioxide will freeze on the cold surfaces in the plant, "seriously impairing the efficiency or in extreme case causing blockages."³ Removal of carbon dioxide is usually achieved by scrubbing with an 8 percent caustic soda solution. Water vapor is removed at each compression stage in catchpots and removed by adsorption on specially prepared alumina.⁴ In the latest air separation plants, two exchangers are used whereby the two stream flow paths can be interchanged by means of "reversing valves" thus permitting the solid deposits of carbon dioxide and water to be purged with the exhaust stream as it is heated via indirect heat transfer with the incoming feed.

3. Din, F. and A. H. Cockett, Low Temperature Techniques
New York: Interscience Publishers, Inc., 1960, p.161.

4. Ibid.

The simple Linde cycle is inefficient because it has two essential disadvantages. First, while 99+ percent oxygen can be produced, only 90 to 93 percent nitrogen can be obtained. Since nitrogen had no commercial value in 1902, this particular problem was of little consequence. Today, however, large quantities of nitrogen are used for "blanketing" purposes, i.e. use as an inert atmosphere, in the electronics and other industries. Nitrogen is also used extensively in the production of ammonia and fertilizers and for its cryogenic characteristics.⁵ However, in 1902 the loss of almost twenty percent of the valuable oxygen with the nitrogen prompted an improvement in design.

To recover the oxygen, the rising nitrogen vapors should be contacted with a liquid stream which is richer in nitrogen. To this end, the basic stripping column of Figure 1 must be extended above point I, and a rectifying section complete with its associated reflux generating equipment added. Theoretically, the tower which is now symmetrical and complete should negate both drawbacks of the stripping section of Figure 1. Unfortunately, the inhibiting factor in the design is the low temperature that would be necessary in the condenser. Fractional distillation above room temperature utilizes cooling water as the heat sink to provide the reflux stream;

5. Simpson, C.H., Chemicals from the Atmosphere, New York: Doubleday, Inc., 1969, p. 139.

but in air separation a heat sink colder than ambient-pressure boiling nitrogen would be needed, colder than -320°F . (140°R .)! The only convenient refrigerating fluids available are air and its products oxygen and nitrogen. Liquid nitrogen boiling at a reduced pressure could be used, but the nitrogen reaches the condenser as a vapor and would first have to be condensed. The only refrigerant available is the liquid oxygen boiling in the reboiler. The boiling point of oxygen is 162°R ., and nitrogen 139°R . Therefore, the vapor pressure of the oxygen would have to be reduced to approximately 90 mm. of mercury (1.741 psia) to lower its temperature to 133°R . The oxygen at this temperature could easily condense the nitrogen boiling at 139°R . Since such a low pressure is difficult to maintain, the alternative is to raise the reflux temperature by increasing the column pressure to 5 atmospheres. The boiling point of nitrogen is now 169°R ., above the 162°R . of oxygen at one atmosphere. The column, as shown in Figure 2, utilizes the oxygen at A" to condense the nitrogen in the condenser at D.

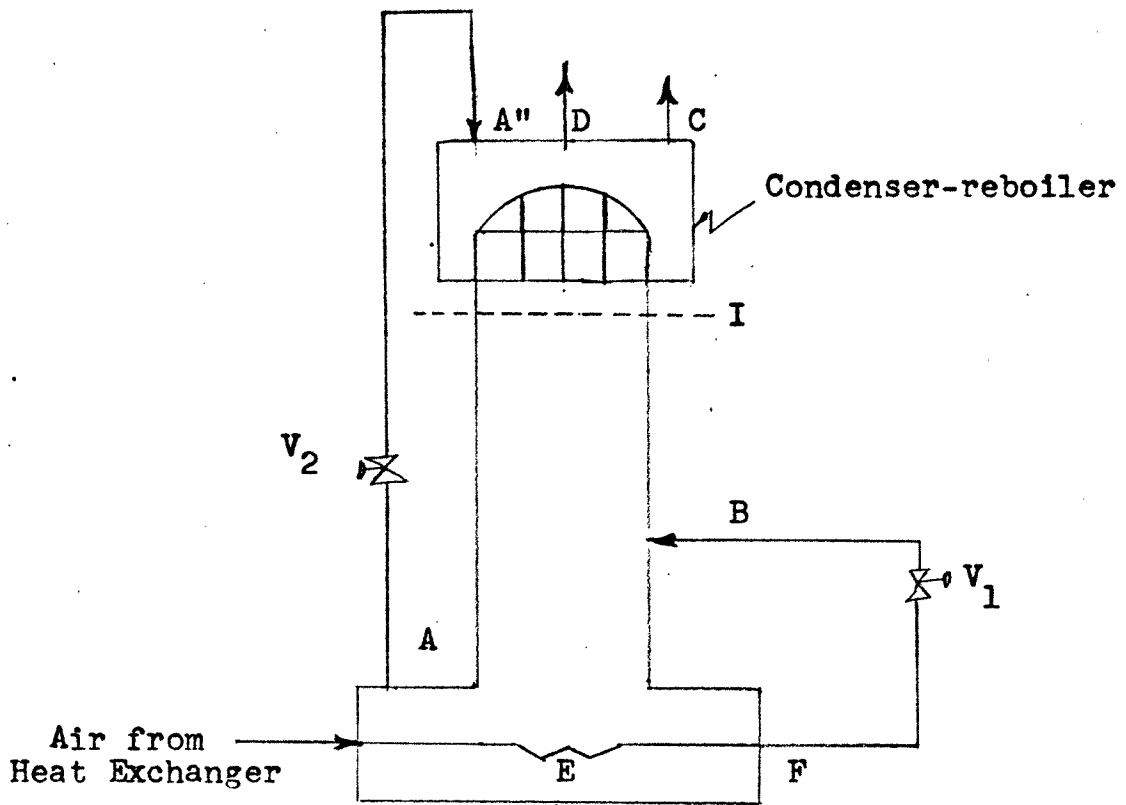

FIGURE 2

B= Air at 5 atmospheres

D= Nitrogen at 5 atmospheres

I= Point where rectifying section was added.

A= Oxygen at 5 atmospheres

A''= Oxygen at 1 atmosphere

C= Bottoms product

Though the problem of condensing the nitrogen has been solved, a column as described in Figure 2 will not produce simultaneously both products in the pure state. Assuming complete separation of the air into oxygen and nitrogen,⁶ and assuming a bubble point feed, an enthalpy concentration diagram gives the amount of heat which must be withdrawn from the condenser per mole of nitrogen product as 873 g-calories per g-mole of N₂ produced. Since the product is pure nitrogen, one mole of entering air produces 0.79 moles of nitrogen product and the condenser duty is therefore 79 per cent of 873, or 690 g-calories. To absorb this heat there exists the latent heat of oxygen at one atmosphere, $\lambda = 1632$ g-calories per g-mole of oxygen. Since every mole of entering air produces 0.21 moles of oxygen, the refrigerating capacity is therefore twenty-one percent of the latent heat or 343 g-calories. From this heat balance it can be shown⁷ that the maximum oxygen purity obtainable, assuming a 100 percent nitrogen product, with a column as in Figure 2 is 60 percent oxygen.

To obtain both pure products simultaneously, the impure oxygen at A must be further purified before entering the

6. Ruhemann, M., The Separation of Gases, Second Edition, London: Oxford University Press, 1952, p. 156.

7. Ibid., p. 157.

condenser. Referring to Figure 3, a set of plates between the condenser-reboiler and A" will purify the impure oxygen stream. Pure nitrogen and oxygen of 99+ percent purity may be simultaneously withdrawn at D and C respectively, however, valuable oxygen, at least the equilibrium vapor at point A", will be lost at E. Again a refrigerant is needed to provide a nitrogen rich stream to absorb the oxygen in the vapor at E. If the column is extended at point E, and liquid nitrogen withdrawn at D is expanded to one atmosphere pressure in a valve, and reintroduced at the top of the column extension, it will absorb the oxygen from stream E which is recovered as part of stream C.

The final result (Figure 4) is the Linde "Double Column" as evolved by Carl Linde in 1910. The column consists of a distillation column operating at 5 atmospheres pressure surmounted by a dual feed reboiled absorber operating at one atmosphere. The final cycle is as described by Ruhemann:⁸

"Compressed air, precooled in a heat exchanger enters the evaporator coil at P, is expanded to 5 atm. pressure in the valve V and delivered to the middle of the lower column at B. Here it is separated into pure liquid nitrogen and a liquid containing about 38 per cent of oxygen. The latter is withdrawn from the lower column at A,

8. Ruhemann, M., The Separation of Gases, Second Edition, London: Oxford University Press, 1952, p.158.

expanded to essentially atmospheric pressure in the valve V_O , and admitted in the middle of the upper column at (A"). The liquid nitrogen collects in the trough below the condenser, whence it is removed at E, expanded to atmospheric pressure in the valve V_N , and admitted at the top of the upper column at E'. Finally gaseous oxygen is withdrawn immediately above the condenser at C and gaseous nitrogen at D. "

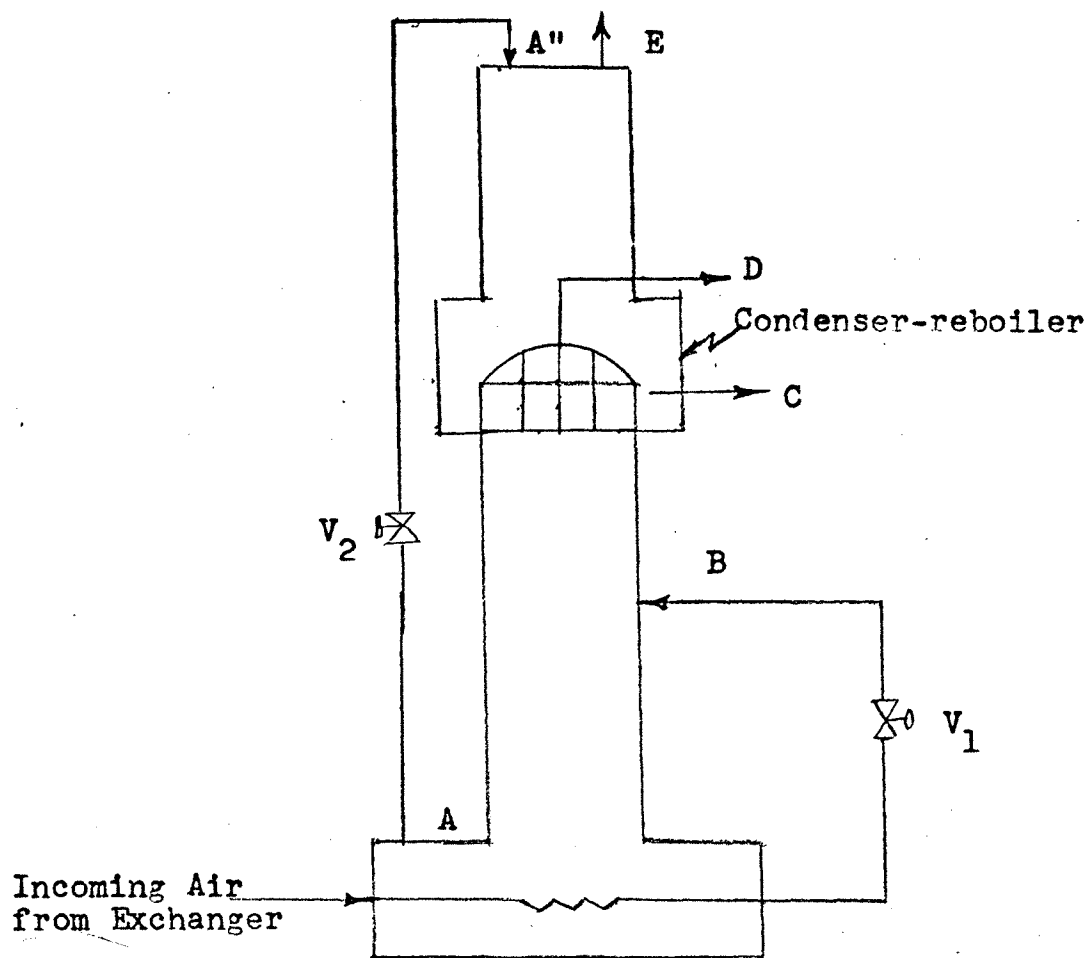

FIGURE 3

B = Air at 5 atmospheres

A''= Oxygen at 1 atmosphere

D= Nitrogen product from lower column

C= Oxygen product

E= Nitrogen product

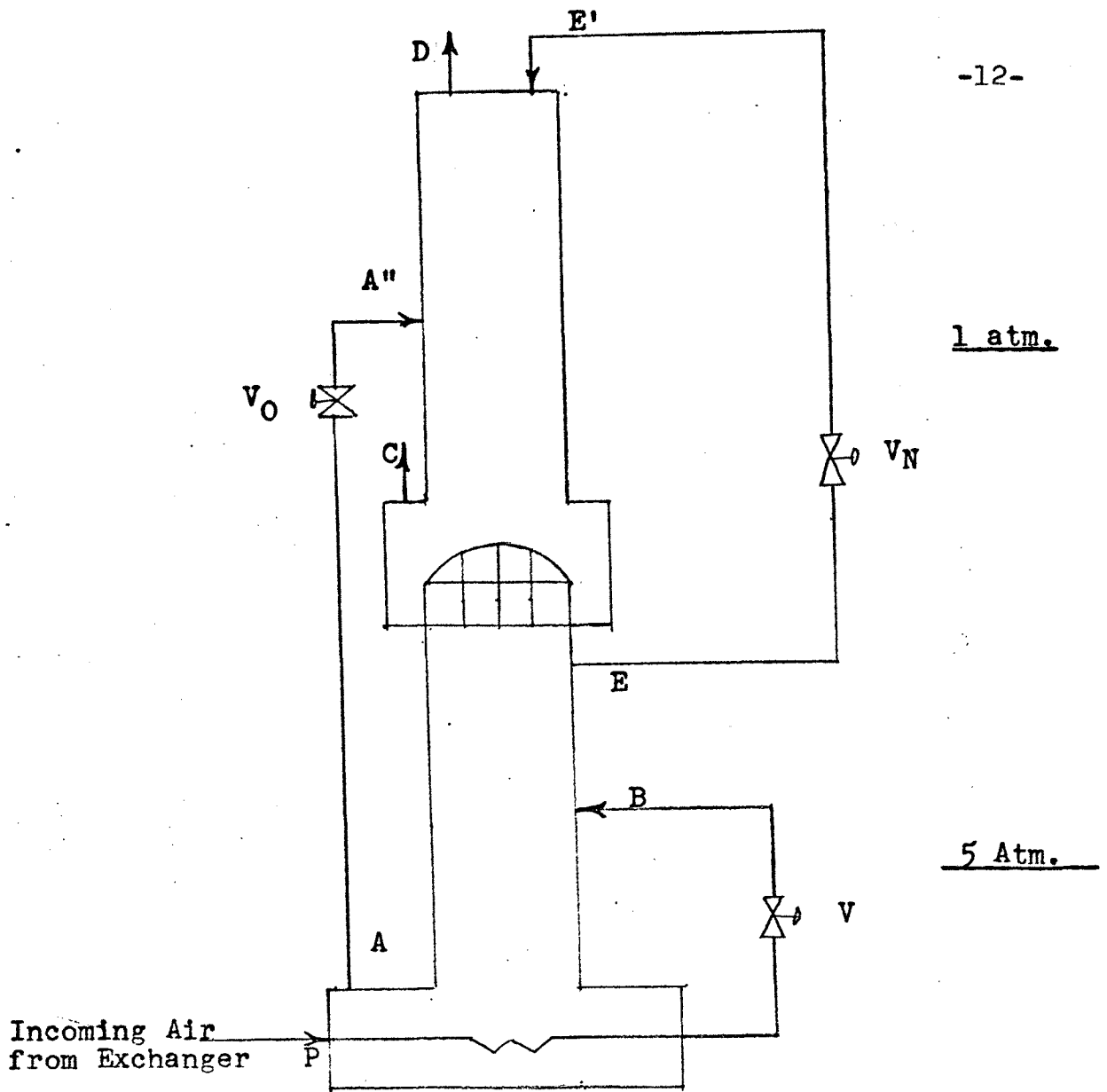

FIGURE 4

A'' = Impure oxygen at 1 atmosphere

B = Air at 5 atmospheres

C= Pure Oxygen product at 1 atmosphere

D= Pure Nitrogen product at 1 atmosphere

E= liquid nitrogen stream at 5 atmospheres

E'= absorber "lean oil feed" stream at 1 atmosphere

CHAPTER II

APPROACH AND METHODS USED

IN DEVELOPING THE MODEL

The purpose of the model is to provide design information; such as, the number of theoretical plates, temperatures, stream rates and compositional profiles for the Linde "Double Column." Since more than 99 percent of the air consists of oxygen and nitrogen, it is considered to be a binary mixture of these compounds in the model. In reality, the approximately 1 percent argon in the air does not allow absolutely pure products to be produced, but for 99 percent pure oxygen and nitrogen the assumption of a binary is adequate. If all the argon is collected with the oxygen, the latter cannot exceed 95 percent in purity; if it is extracted with the nitrogen and the oxygen is pure, the purity of the nitrogen cannot exceed 98.7 percent. Distributed argon will allow approximately 99 percent pure oxygen and nitrogen to be produced. Future work could incorporate the effect of argon into the model and allow for a more accurate design. Further, assumption of a binary mixture allows use of the Sorel¹ method of calculation which is a rigorous plate to plate method utilizing

1. Sorel, M., "La Rectification de l'alcool," Paris, 1893.

alternating material and enthalpy balances, coupled with the equilibrium vapor-liquid relationships. The method has been extended by Lewis and Matheson to multicomponent systems and a simplified version has been used in a graphical representation by McCabe and Thiele.

The model itself consists of three sections:

(1) input and preliminary calculations, (2) iterative calculations in each column, and (3) output.

Input and Preliminary Calculations

Input to the model comprises three categories:

(1) system options, (2) tower parameters, and (3) basic data.

1. System options. The system options are a set of three codes which specify the distillate and feed thermal conditions, and the tower configuration used. All thermal conditions from a subcooled liquid to a superheated vapor are allowed in the feed. Only a superheated vapor distillate, which is physically impossible, is prohibited as a distillate thermal condition. Three tower configurations are possible within the framework of the model: a single tower, a double distillation tower with either product stream of the first tower becoming a feed stream to the second tower, and the Linde "Double Column."

2. Tower parameters. Twelve tower parameters are required to define the problem for each tower:

- A. Feed rate, lb-moles/hour.
- B. Feed composition, mole fraction light component.
- C. Reflux factor, $R(\text{actual})/R(\text{min})$, dimensionless.
- D. Pressure drops across condenser, each plate and the reboiler, psi.
- E. Equilibrium data reference pressure, psia.
- F. Tolerances on bubble-dew point component summations and overall tolerance on composition, lb-moles.
- G. Initial temperature and pressure estimates at top and bottom of column, $^{\circ}\text{F}$. and psia.
- H. Minimum product purities distillate and bottoms, mole fraction light component.

Note: If the thermal conditions of the feed and distillate are other than saturated liquid or vapor, the appropriate feed and/or condenser temperatures must be given as input. If a partial condenser is used, the fraction vapor distillate must be input to the model. A complete input form appears in Appendix A.

3. Basic data. The final block of input data consists of the vapor-liquid equilibrium data and the enthalpy data. The equilibrium constant for each component is computed

from the equation:

$$\ln(KP) = A + B/T$$

where, K = equilibrium constant, dimensionless.

P = stage pressure, psia.

T = temperature, °R.

A & B = correlation constants defined by:

$$B = \ln(K_1/K_2) * (T_1 T_2 / (T_2 - T_1))$$

and
$$A = \ln(K_1 P_{ref}) - B/T_1$$

where the subscripts (1) and (2) refer to two different temperatures and P_{ref} is the equilibrium reference pressure.

This correlation pressure corrects the equilibrium constant to the pressure at each plate in the column.

Enthalpy values are calculated from the linear equations:

$$h = a_h + b_h T$$

and

$$H = A_H + B_H T$$

where, h, H = liquid and vapor component enthalpies,
Btu/lb-mole.

T = temperature, °R.

a_h, b_h, A_H, B_H = correlation constants.

For each component two vapor-liquid equilibrium values and four enthalpy points (two liquid, two vapor) are required as input. Enthalpy values are combined using Kay's rule to

obtain the mixture values:

$$h_{avg} = \sum x_i h_i$$

or,

$$H_{avg} = \sum y_i H_i$$

where, h_{avg} , H_{avg} = average enthalpy (liquid or vapor),
Btu/lb-mole.

h_i , H_i = component liquid or vapor enthalpies,
Btu/lb-mole.

x_i , y_i = light component mole fraction (liquid
and vapor).

Preliminary Calculations.

Before the iterative procedure can be implemented, three preliminary calculations are made; namely, (1) feed condition evaluation, (2) minimum reflux determination, and (3) condenser duty evaluation.

1. Feed condition evaluation. Based on the feed code entered, the feed temperature is determined by a bubble or dew point calculation. If a flashed, subcooled, or superheated feed is specified, the feed temperature must be supplied. At this temperature and the average tower pressure, the feed vapor and liquid compositions, and the fraction

vaporized are determined as follows:

$$x = (1-K_2)/(K_1-K_2)$$

$$y = K_1 x$$

$$\text{Fraction vapor} = (z-x)/(y-x)$$

where, K_1 and K_2 are the equilibrium constants of components (1) and (2) at the feed temperature and pressure.

z = the bulk feed composition for the light component.

Using the feed compositions, temperature, and the fraction vapor, the feed enthalpy is computed.

2. Minimum reflux determination. The minimum reflux ratio is determined by linear interpolation between the minimum reflux based upon a dew and bubble point feed condition using the fraction feed vaporized as the correlating factor. Utilizing a concept from the McCabe-Thiele graphical method for binary systems, the operating line slope is related to the reflux ratio by:²

$$\text{Slope} = (x_D - y)/(x_D - x_F) = R/(R+1) \quad (1)$$

where, x_D = distillate composition of light component.

y = point where operating line intersects feed locus line.

x_F = feed composition of light component.

2. Smith, Buford D., Design of Equilibrium Stage Processes, New York: McGraw-Hill Book Co., 1963, p. 130.

If the point of intersection of the operating line and the feed locus line, y , is taken at the intersection of the operating line and the equilibrium curve, the minimum reflux ratio can be evaluated by an equation similar to (1):

$$\text{Slope}(\min) = R_{\min} / R_{\min} + 1.$$

For a bubble point feed, the slope is given by:

$$\text{Slope}_L = (x_D - Kx_F) / (x_D - x_F) = (R_{\min} / (R_{\min} + 1.))_L$$

where, K = the equilibrium constant at the feed temperature and pressure .

For a dew point feed, the slope is given by:

$$\text{Slope}_V = (x_D - x_F) / (x_D - (x_F / K)) = (R_{\min} / (R_{\min} + 1.))_V$$

From the above equations, the minimum reflux ratios for a bubble and dew point feed are evaluated, and the composite minimum reflux obtained from the equation:

$$R_{\min} = f \cdot R_{\min V} + (1.-f) \cdot R_{\min L}$$

where, f = fraction feed vaporized

$R_{\min V}$, $R_{\min L}$ = the vapor and liquid minimum refluxes respectively.

Finally, the operating reflux ratio is calculated as the product of the reflux factor and the minimum reflux ratio.

3. Condenser duty evaluation. The distillate drum pressure equals the column top pressure minus the condenser pressure drop. The distillate rate is fixed for

the column by the equation:

$$D = F * (x_F - x_B) / (z_D - x_B)$$

where, F = feed rate, lb-moles/hr.

x_F = feed composition, light component

x_B = bottoms composition, light component

z_D = distillate composition, light component

Based on the distillate code chosen, the condenser temperature is obtained by a bubble or dew point calculation. For a subcooled distillate, this temperature must be supplied. For a partial condenser, the liquid-vapor split must be specified so that the flash temperature can be calculated. With the temperature and pressure specified, equations similar to those used in the feed evaluation section are used to evaluate the vapor and liquid compositions of the distillate, and the fraction distillate vaporized.

Referring to Figure 5, the following procedure is followed:

- A. The composition of the vapor and liquid from plate 1 are determined:

$$y_1 = (D_V y_D + D_L x_D + L_0 x_D) / V_1$$

where, $L_0 = RD$

$$V_1 = L_0 + D$$

T_1 = dew point temperature of V_1

$$x_1 = y_1 / K_1$$

- B. The distillate enthalpy is evaluated:

$$DH = D_L h_{D_L} + D_V H_{D_V}$$

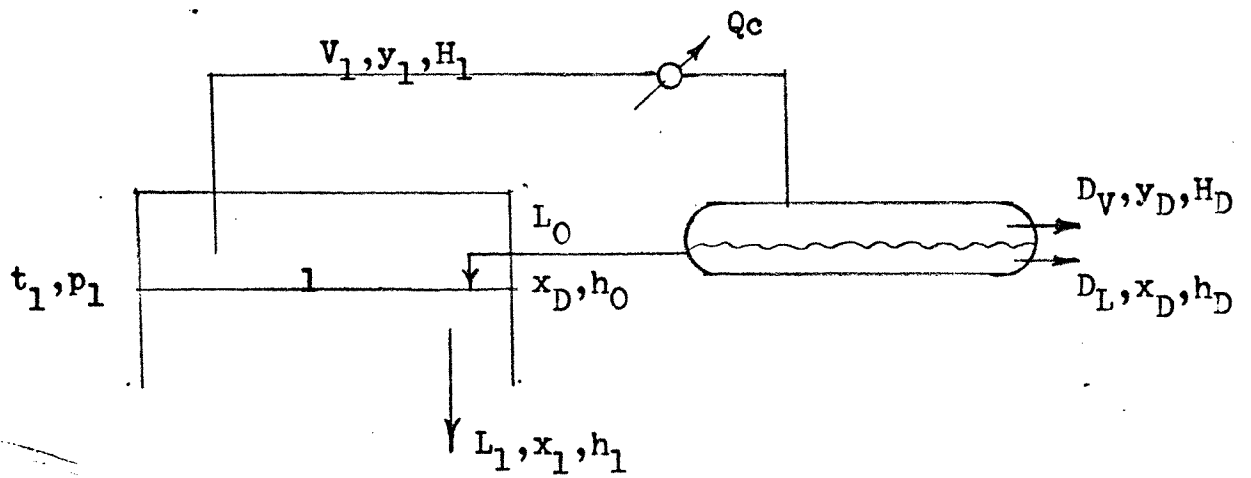

FIGURE 5

and by a heat balance, the condenser duty is:

$$Q_c = L_0 h_0 + D H - V_1 H_1$$

Iterative Calculations

The iterative calculations for each column are divided into three sections; the rectifying section, the feed zone and the stripping section.

1. High pressure tower-rectifying section. Calculations for the high pressure tower begin at the condenser and proceed toward the reboiler. Referring to Figure 6, the following procedure is followed:

- A. The composition of x_1 is determined by equilibrium; $x_1 = y_1/K_1$
- B. The composition of y_2 is assumed.
- C. A dew point calculation determines t_2 .
- D. L_1 and V_2 are calculated by material balance (envelope).

$$L_1 = (D_L x_D - D_L y_2 + D_V y_D - D_V y_2) / (y_2 - x_1)$$

$$V_2 = (D_L x_D - D_L x_1 + D_V y_D - D_V x_1) / (y_2 - x_1)$$

an energy balance determines the criteria for convergence:

- E. $Eqn = V_2 H_2 - L_1 h_1 + Q_c$
- F. The value of Eqn is compared with the distillate enthalpy, and steps A to E repeated until converged.

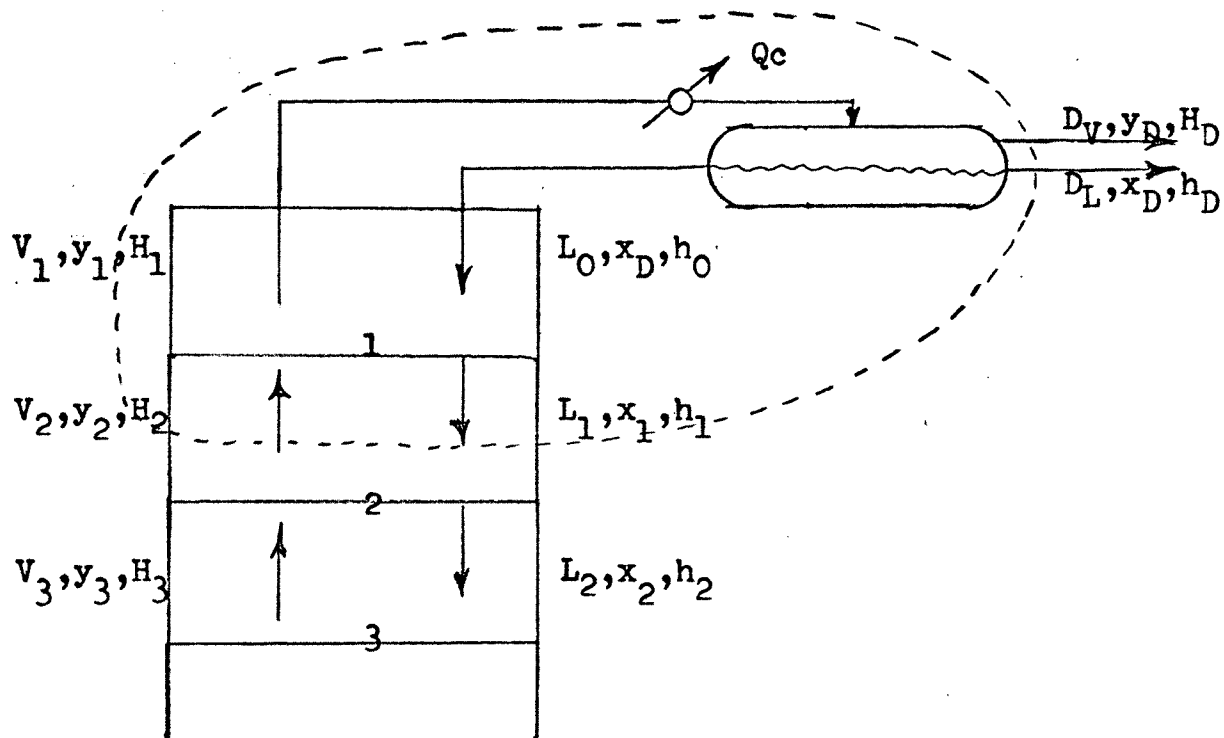

FIGURE 6

2. High pressure tower-feed zone. The feed zone refers to that area of the tower where the computed compositions of the vapor and liquid approximate those obtained from the feed flash calculation. The calculations in this region differ from those in the rectifying section in that the material and enthalpy balances are performed between stages and not around the condenser. At the feed zone, the following procedure is followed (Figure 7):

- A. The composition of x_f is calculated by equilibrium; $x_f = y_f/K_f$
- B. The composition of y_{f+1} is assumed.
- C. A dew point calculation determines t_{f+1} .
- D. V_{f+1} is determined by a material balance around stages $f-1$ and f (envelope I).

$$\text{Eqn}_1 = V_{f+1} = (V_f y_f - V_{\text{feed}} y_{\text{feed}} - L_{f-1} x_{f-1} + (V_{\text{feed}} + L_{f-1} - V_f) x_f) / (y_{f+1} - x_f)$$

- E. V_{f+1} is also determined by an enthalpy balance around stages $f-1$ and f (envelope I).

$$\text{Eqn}_2 = V_{f+1} = (V_f H_f - V_{\text{feed}} H_{\text{feed}} - L_{f-1} h_{f-1} + (L_{f-1} + V_{\text{feed}} - V_f) h_f) / (H_{f+1} - h_f)$$

- F. The values of Eqn_1 and Eqn_2 are compared until converged.

Steps A to F are repeated for stages f and $f+1$ (envelope II), with the liquid feed being added to the system.

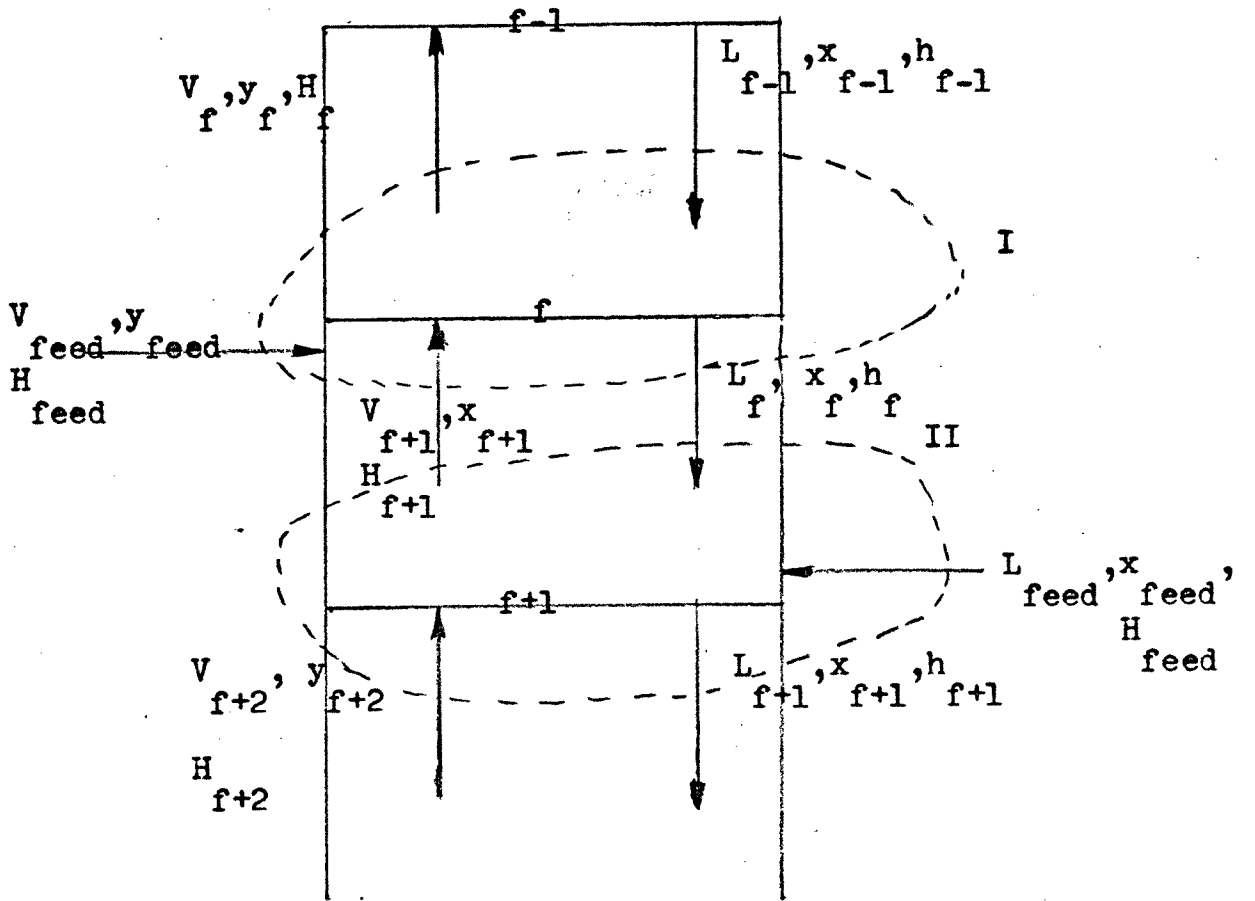

FIGURE 7

3. High pressure tower-stripping section. The stripping section calculations correspond to those used in the rectifying section, with only a modification in the material and enthalpy balances to reflect the addition of the feed stream to the tower. Referring to Figure 8, the procedure is as follows:

- A. The composition of x_{f+3} is determined by equilibrium; $x_{f+3} = y_{f+3}/K_{f+3}$
- B. The value of y_{f+4} is assumed.
- C. A dew point calculation fixes t_{f+4} .
- D. L_{f+3} and V_{f+4} are computed from a material balance around the condenser (envelope):

$$L_{f+3} = (D_L x_D - D_L y_{f+4} + D_V y_D - D_V y_{f+4} + F y_{f+4} - F z_F) / (y_{f+4} - x_{f+3})$$

$$V_{f+4} = (D_L x_D - D_L x_{f+3} + D_V y_D - D_V x_{f+3} + F x_{f+3} - F z_F) / (y_{f+4} - x_{f+3})$$

an energy balance determines the criteria for convergence:

$$E. \quad Eqn = V_{f+4} H_{f+4} - L_{f+3} h_{f+3} + Q_c + H_{Feed_{TOT}}$$

The value of Eqn is compared with the distillate enthalpy, and steps A to E repeated until converged.

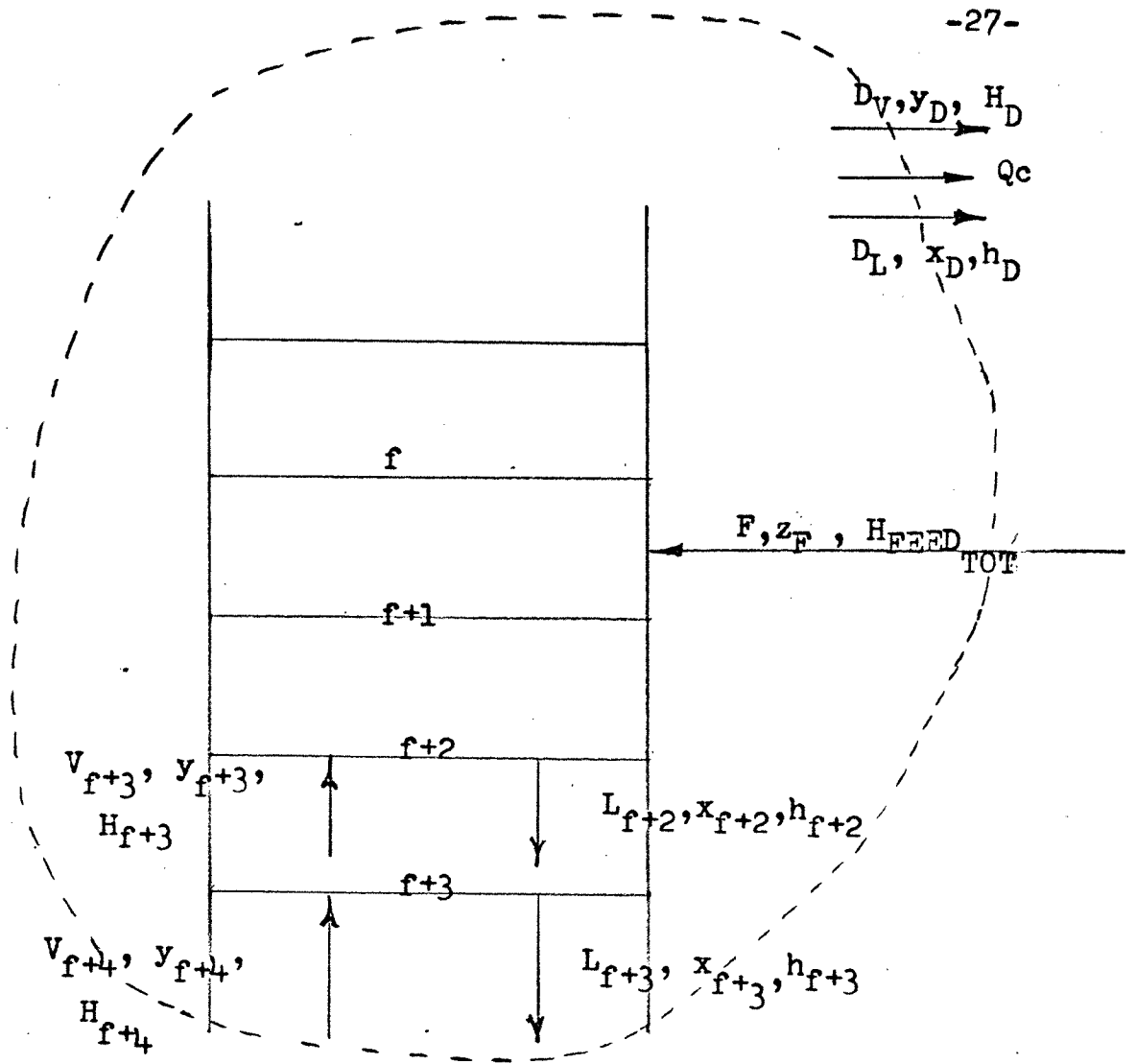

FIGURE 8

Iterative Calculations- Overall Program Logic

The overall program logic consists of three separate calculational blocks: (1) the high pressure tower, (2) the two isenthalpic valves between columns, and (3) the second distillation tower or the absorber section. Each column computational block is further subdivided into two separate routines; an initialization routine, and a convergence routine.

1(a) . High pressure column-initialization routine.

Calculation begins at the condenser and proceeds downward by repetitive application of the rectifying section procedure previously outlined. Computations continue until the computed liquid composition equals or becomes less than the feed liquid composition. The calculations now shift to the reboiler, and a procedure similar to that used in the rectifying section is employed except that the material and enthalpy balances are performed around the bottoms product stream and calculations are made from the reboiler upward.

Referring to Figure 9, the procedure is :

- A. The composition of y_2 is calculated by equilibrium; $y_2 = K_2 x_2$
- B. The composition of x_3 is assumed.
- C. A bubble point calculation determines the temperature t_3 .

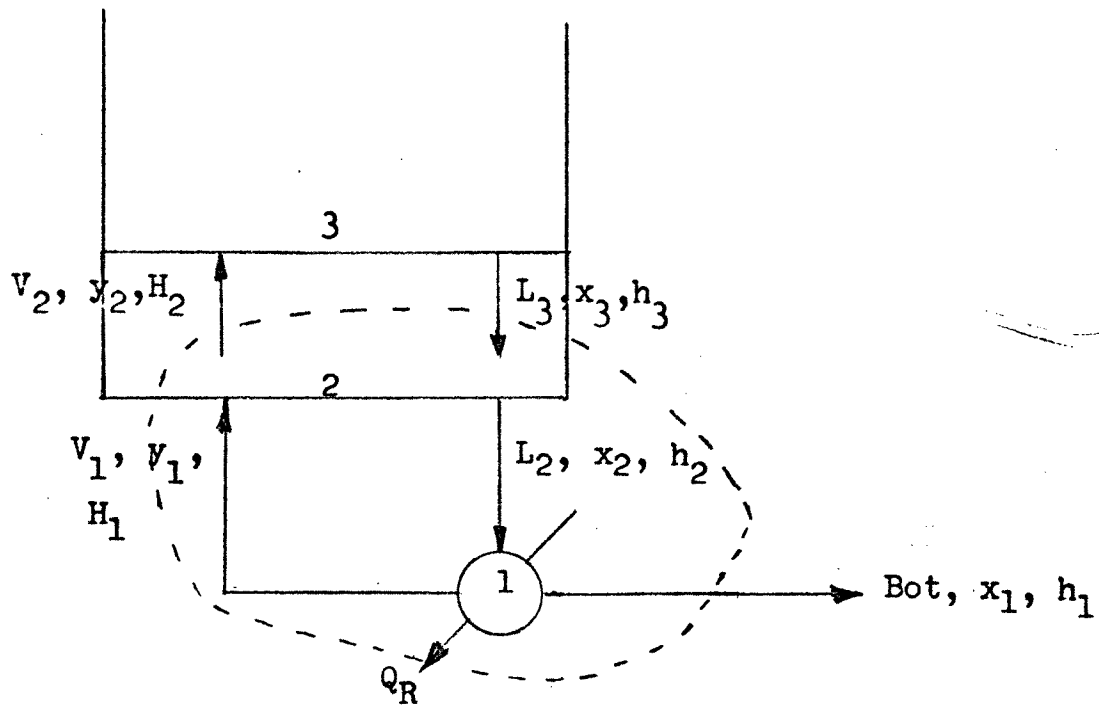

FIGURE 9

D. L_3 and V_2 are determined by material balance (envelope) :

$$L_3 = \text{Bot} \cdot (x_1 - y_2) / (x_3 - y_2)$$

$$V_2 = \text{Bot} \cdot (x_1 - x_3) / (x_3 - y_2)$$

an energy balance determines the criteria for convergence:

E.
$$\text{Eqn} = L_3 h_3 - V_2 H_2 + Q_R$$

The value of Eqn is compared with the bottoms enthalpy, and steps A to E repeated until converged.

Calculation in the stripping section continues until the computed vapor composition exceeds the feed vapor composition. At the conclusion of the first pass, the number of stages and the feed stage location are fixed.

1(b) . High pressure column-convergence routine. After pressure corrections have been made to reflect the true number of stages in the column, the calculations are repeated starting at the condenser. As before, the rectifying region series of calculations is repeated until the feed zone is reached. Computations now proceed through the feed stage using the feed zone procedure, and then continue with the stripping section procedure described for Figure 8. The reflux ratio is now adjusted and the entire calculational block repeated until the desired bottoms composition is attained.

2. Isenthalpic valves. If only a single tower is to be solved, the calculations cease. However, if a second tower exists, the product streams from the high pressure tower must be reduced to approximately atmospheric pressure. Equilibrium and enthalpy data at the lower pressure are input, and depending upon the tower configuration either one or both valves are simulated. The valve simulation is a trial and error procedure wherein the constant enthalpy across the valve is the criteria for convergence. The procedure used is as follows:

- A. A temperature is assumed between the bubble and dew points at the lower pressure.
- B. A feed flash at this temperature yields the liquid and vapor compositions.
- C. The combined enthalpy of the product liquid and vapor streams is calculated.
- D. The composite enthalpy computed above is compared with the enthalpy of the stream before the valve.
- E. Steps A to D are repeated until convergence is achieved.

If a double distillation tower configuration is used, only the bottoms or distillate product is pressure reduced. If the Linde "Double Column" is used, both product streams undergo pressure reduction.

3. Second distillation tower or absorber. If the second tower is a distillation column, the pressure reduced product stream (bottoms or distillate) becomes the feed stream to this low pressure column. The calculational scheme is exactly the same as in the high pressure column, and after the second column bottoms composition is converged calculations cease. If, however, the second tower is an absorber, the calculations are somewhat more involved. As in the high pressure tower, the computational block is subdivided into an initialization routine and a convergence routine.

3(a) . Absorber-initialization routine. Since a condenser does not exist in the reboiled absorber, calculations cannot begin at the condenser. Because the heat to the reboiler is supplied by the condenser of column one, it is logical to begin the calculations at this point. Pursuant to the fact that the vapor products are required, the reboiler is assumed to be a total reboiler, and the appropriate adjustment to the enthalpy balance for the reboiler calculation is made. Proceeding up the absorber, calculations similar to those described for the "stripping section," Figure 9, are performed. Calculations proceed until the computed vapor composition becomes equal to or less than the feed vapor composition.

Proceeding through the feed stage, a computational

approach that is similar to the feed zone calculation of the high pressure tower is utilized except that calculations are from the bottom up and the liquid composition rather than the vapor composition is unknown.

After the feed zone, calculations follow the procedure of the high pressure stripping section with a shift to bottom up and unknown liquid composition as in the feed zone calculations above. Calculations continue until the computed liquid composition equals or exceeds the value of the "lean oil" feed composition determined by the valve calculation.

3(b) . Absorber-convergence routine. Even though the liquid composition computed now equals or exceeds the required value, the computed rate of flow of the "lean oil" feed stream will, in general, not match the required value. Two adjustments must be made for the absorber to be independently balanced. First, the variations in the pressure of the feed stage must be dampened out, and second, the computed "lean oil" feed rate must be adjusted to the value obtained from the valve calculation.

To achieve the first objective, the initialization procedure for the absorber is repeated until there is no variation in the feed stage location. Unfortunately the second problem is more involved. Since there is no condenser, the reflux ratio does not exist, and another means of adjusting the "lean oil" flow rate must be devised. To

meet the "lean oil" requirement, the reboiler duty of the absorber is adjusted until the required rate is obtained. The absorber is now independently but unfortunately also arbitrarily converged.

Iterative Calculations-Overall Convergence

The arbitrary value of the reboiler duty as set in the previous section is now practically approached by adjusting the number of contact stages in the high pressure tower by means of the bottoms composition. The bottoms composition is adjusted, and the entire calculational loop is repeated until no further adjustment of the absorber reboiler duty is required. An elaboration of the problems encountered in this type of convergence will be made in the next chapter.

Output

The computer output generated incorporates all the information necessary to design the Linde "Double Column." Output is generated as each tower is independently converged, and intermediate trials indicate only the convergence trend. The tower parameters and calculated constants are printed and act as a check on the input data. The initialization routine, which determines the number of stages required, is printed in entirety. The first convergence routine pass is also printed in entirety so that the method of calculation

can be illustrated. Subsequent passes are suppressed, and only the direction of convergence is indicated. The final converged trial is printed in its entirety, including the five profiles of temperature, pressure, vapor flow rate, liquid flow rate and light component composition. Lastly, an enthalpy balance is presented incorporating all tower input and output streams. A sample of the output is presented with the examples of Chapter IV.

CHAPTER III

CONVERGENCE PROBLEM

As indicated in the previous chapter, the problem of convergence in a Linde "Double Column " involves ramifications which are nonexistent in an ordinary dual column fractional distillation complex. Whereas in a distillation plant operating above the ambient temperature, the reflux ratio, and hence the condenser and reboiler heat loads can be varied within wide limits, the lack of a condenser on the absorber negates the use of a simple "key" to control convergence. Unlike the ambient temperature columns, the heat loads of the high pressure column's condenser and the absorber's reboiler are interdependent and the entire high pressure tower must be adjusted to achieve convergence. The method used to adjust the high pressure column's condenser duty is to adjust the bottoms composition. Initially this procedure has the effect of changing the number of contact stages and therefore increasing or decreasing the condenser duty. A fine adjustment is achieved as the number of stages remains constant and only the bottoms enthalpy varies.

Unlike the reflux ratio which can vary from minimum to infinity, the variation of the high pressure column bottoms composition, x_{B1} , is set between narrow theoretical

and even tighter practical limits. Figure 10 illustrates the "Double Column" construction on an enthalpy concentration diagram.¹ Line Z'AR' represents the "lean oil" feed in the absorber, and at a value of x_{B_1} approximately equal to 0.67, it coincides with the "tie line" through A, i.e. the minimum reflux ratio the absorber would theoretically have.

Similarly, line RBZ corresponds to the reflux ratio in the high pressure column, and at a value of x_{B_1} equal to approximately 0.57, the line coincides with the "tie line" through B, i.e. the minimum reflux ratio for the high pressure column. The theoretical limits for the light key bottoms composition are therefore 0.57 and 0.67. As Ruhemann states: "Practically x_A (x_{B_1}) can vary between 60 and 64 per cent."² This is a small margin indeed and indicates just how sensitive the convergence problem can be.

During development of the model, another convergence problem emerged. Unlike the first convergence problem which is a physical limitation of the system, this problem results from the method of calculation used. The Sorel method was originally developed by Sorel in 1896, before the age of computers. Utilizing graphs of the equilibrium and enthalpy

1. Ruhemann, M., The Separation of Gases, Second Edition, London: Oxford University Press, 1952, p. 159.

2. Ibid., p. 160.

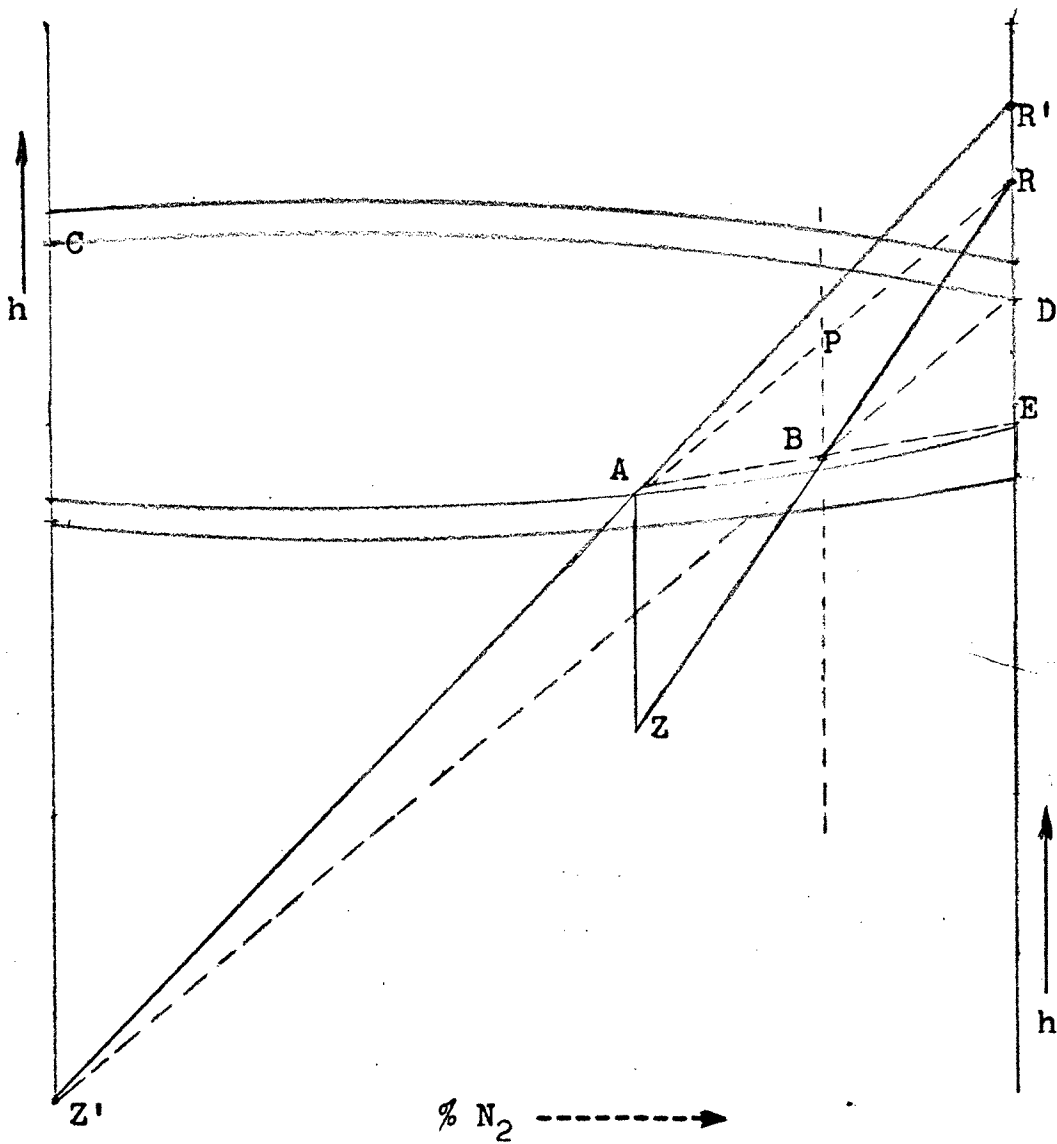

FIGURE 10

functions, and designed for hand calculation, the tolerances for convergence were extremely loose. The feed stage calculation, especially, was solved by the addition of the feed stream between two stages with no attempt made to add the feed liquid to one plate and the feed vapor to another stage. When the former method was applied to a computer with a tolerance on composition of 10^{-4} or tighter, the discrepancy caused the enthalpy balance to fail to converge and a zone of constant composition appeared. No solution to the problem was possible since the "pinch point" could not be passed. Subsequently, the feed zone equations were rewritten to incorporate the effect of separate addition of the feed liquid and feed vapor plus a much more restrictive tolerance on the appropriate equilibrium calculations. The result of these modifications to the computational algorithm resulted in a converged solution to the set of material-equilibrium-enthalpy equations.

CHAPTER IV

EXAMPLE PROBLEMS

This chapter contains three example problems chosen to illustrate the model's ability to solve problems of varying complexity.

Example No. 1 : The design of a Linde "Double Column" for the separation of air into oxygen and nitrogen.

Example No. 2 : The design of a single fractional distillation column separating benzene and toluene.

Example No. 3 : The design of a dual fractional distillation complex for the separation of benzene and toluene.

A. Example No. 1 - Linde "Double Column."

The purpose of this example is to solve the problem for which the model was developed, the design of a Linde "Double Column." The necessary input data are:

1 (A) Select system options

(a) Tower type code = 4

Linde "Double Column."

(b) Feed thermal code = 3

A bubble point feed is the most advantageous condition.¹

(c) Distillate thermal code = 3

A bubble point distillate will be the best "lean oil" feed to the absorber.

2 (A) Set tower parameters

(a) Feed rate = 100 lb-moles/hour

A convenient number was chosen to simplify the calculational check. The feed rate should not exceed 100,000 lb-moles/hour so as to avoid an output format error.

(b) Feed composition light key = 0.79

Air is considered as a binary containing 79 percent nitrogen.

1. Ruhemann, M., The Separation of Gases, Second Edition, London: Oxford University Press, 1952, p. 156.

(c) Reflux factor = 1.1

Air plants normally operate close to minimum reflux.

(d) Pressure drops--stage=0.1 psi., condenser= 0.3 psi., reboiler= 0.1 psi. Pressure drops per stage range from 0.07 to 0.15 psi.² Condenser and reboiler pressure drops are generally higher due to the increased piping associated with these sections.

(e) Equilibrium reference pressure= 73.5 psia. The suggested pressure for the distillation tower is 5 atmospheres absolute.

(f) Tolerances = 10^{-6} and 10^{-4}
 The tolerance on the bubble or dew points (component summations) = 10^{-6} ; i.e. $\sum Kx$ or $\sum y/K = 1.0 \pm 10^{-6}$. The overall tolerance, 10^{-4} , is on the bottoms composition of the light component (x_{B1}).

(g) Initial temperature and pressure estimates:

	<u>TOP</u>	<u>BOTTOM</u>
T, °F.	-280.3	-274.0
P, psia	73.8	78.8

2. Peters, M.S. and K.D. Timmerhaus, Plant Design and Economics for Chemical Engineers, Second Edition, New York: Mc Graw-Hill Book Co., 1968, p. 622.

The initial temperature estimates are used only for initialization and need not be very accurate. The pressure estimates are used in the determination of the number of stages, and therefore can have an effect on the tower convergence.

(h) Product purities, light component:

overhead= 0.98 : bottoms= 0.60

The bottoms composition is within the practical limits discussed in chapter III.

3 (A) Basic data

(a) Enthalpy data

Liquid and vapor enthalpy values for both components at -289°F . and -266.1°F . were estimated from an "Esso Blue Book" graph supplied by Dr. Edward C. Roche, Jr., and input in the order: (1) temperature($^{\circ}\text{F}$.), (2) liquid enthalpies (Btu/lb-mole), and (3) vapor enthalpies(Btu/lb-mole).

(b) Equilibrium data

Vapor-liquid equilibrium data for each component³ were entered at temperatures of -289°F . and -266.1°F . The values were

3. Van Winkle, M., Distillation, New York: Mc Graw-Hill Book Company, 1967, p.284.

input in the following order:

- (1) temperature ($^{\circ}\text{F.}$), (2) light component equilibrium constant, and
- (3) heavy component equilibrium constant.

2 (B) Absorber tower parameters

- (d) Pressure drops--stage=0.1 psi., condenser=0.3 psi., reboiler=0.1 psi.
The same values as were used in the high pressure column.
- (e) Equilibrium reference pressure=14.7 psia.
- (f) Tolerances = 10^{-6} and 10^{-4}

The same values as were used in the high pressure column.

- (g) Initial temperature and pressure estimates:

	<u>TOP</u>	<u>BOTTOM</u>
T, $^{\circ}\text{F.}$	-310.9	-307.7
P, psia.	15.0	20.0

- (h) Product purities, light component:
overhead= 0.99 : bottoms= 0.01

3 (B) Absorber basic data

- (a) Enthalpy data

As in the high pressure column, enthalpy data at -319.7°F. and -300.0°F. were supplied to the model from the "Esso Blue Book" graph previously mentioned.

(b) Equilibrium data

As before, vapor-liquid equilibrium data⁴ for each component were supplied to the model at -319.7°F . and -300.0°F .

The above data were inserted into the model and the results are that the high pressure tower requires 7 stages plus a reboiler and a condenser, the bottoms composition of the light key is 0.61, and the reflux ratio is 0.98649. The condenser and reboiler duties are 203,940 and 204,195 Btu/hour, respectively. The absorber requires 13 stages plus a total reboiler (see attached printout). The high pressure column was checked using DISTL, a rigorous distillation program developed by Dr. Edward C. Roche, Jr. The solution checks favorably within the tolerance limits. A check on the absorber using ABSR, a rigorous absorber program developed by Mr. Robert Lukach and Dr. Edward C. Roche, Jr. also gave favorable results.

4. Van Winkle, M., Distillation, New York: McGraw-Hill Book Company, 1967, p. 284.

---COLUMN_NUMBER---1-----PROBLEM NUMBER

-----TOTAL CONDENSER===ALL LIQUID DISTILLATE-----

INPUT DATA USED IN CALCULATIONS

FEED RATE XF(1) XB(1) DIST.RATE DIST.SPLIT ZD(1)
MOLS/HOUR MOLS/HOUR

100.00000 .790000 .600000 49.99995 0.00000 .980000

PRESSURE DROP/STAGE=0.1000 CONDENSER PRESSURE DROP=0.3000 REBOILER PRESSURE DROP=0.1000

-----*****CONSTANTS*****-----TOWER_NUMBER_1-----

	EQUILIBRIUM	PRESSURE	ENTHALPY-LIQUID	ENTHALPY-VAPOR
A1	11.41600	73.50000	-743.70459	4259.03900
B1	-1206.56730	73.50000	17.13020	0.00000
A2	10.15647	73.50000	-213.52954	4339.14060
B2	-1151.48900	73.50000	13.97386	4.19216

BUBBLE POINT FEED

THE FRACTION FEED VAPORIZED= 0.0001

XFEED= 0.78999 YFEED= 0.90614 HFEED= 0.22290438E 06 TFEED=-286.24707

MINIMUM REFLUX = 0.63588 REFLUX RATIO= 0.69947

THE FRACTION DISTILLATE VAPORIZED= 0.0007

TEMPERATURES---DEGREES FAHRENHEIT

TOP	BOTTOM	FEED	CONDENSER
-280.30005	-274.00000	-286.24707	-290.21606

PRESSURES---PSIA

PTOP= 73.80000	PBOTTOM= 78.80000
----------------	-------------------

FIRST PASS---DETERMINATION OF NUMBER OF STAGES

RECTIFYING SECTION

STAGE	TEMPERATURE DEGREES F	LIQUID RATE MOLES/HR.	VAPOR RATE MOLES/HR.	PRESSURE PSIA
COND.	-290.21606	49.99995	0.00000	73.50000
1	-289.67944	34.83177	84.97330	73.80000
2	-289.21021	34.46559	84.83192	73.89999
3	-288.76343	34.31805	84.46524	73.99998
4	-288.35132	34.11691	84.31810	74.09998
5	-287.98462	33.95007	84.11673	74.19997
6	-287.66724	33.87671	83.94994	74.29996
7	-287.39648	33.61829	83.87653	74.39995
8	-287.17651	33.56702	83.61823	74.49994
9	-286.99365	33.39804	83.56694	74.59993
10	-286.84790	33.47160	83.39790	74.69992

THE NET VAPOR ENTERING THE RECTIFYING SECTION IS 83.47151

STAGE	X(1)	Y(1)
1	0.9505086	0.9799908
2	0.9219195	0.9678856
3	0.8954541	0.9562954
4	0.8717471	0.9455838
5	0.8513058	0.9360884
6	0.8341948	0.9279497
7	0.8201004	0.9211059
8	0.8091582	0.9157078
9	0.8004780	0.9113712
10	0.7940014	0.9081022

THE NUMBER OF STAGES IN THE RECTIFYING SECTION ARE 10

STRIPPING SECTION

STAGE	TEMPERATURE DEGREES F	LIQUID RATE MOLES/HR.	VAPOR RATE MOLES/HR.	PRESSURE PSIA
11	-285.48438	134.21709	84.33714	78.59998
12	-285.30298	133.99014	84.21704	78.69998
13	-284.82056	133.04175	83.99010	78.79999
REB. 14	-281.67847	50.00005	83.04169	78.89999

THE NET LIQUID ENTERING THE STRIPPING SECTION IS 134.33719

STAGE	X(1)	Y(1)
11	0.7892518	0.9058817
12	0.7809044	0.9016114
13	0.7560924	0.8885984
REB. 14	0.6000000	0.8500769

THE NUMBER OF STAGES IN THE STRIPPING SECTION ARE 4

THE TOTAL NUMBER OF STAGES IN TOWER ARE 14

PASS NUMBER 1 IS COMPLETE

REVISED VALUES BASED ON TRUE PRESSURE PROFILE

BUBBLE POINT FEED

THE FRACTION FEED VAPORIZED= 0.0001

XFEED= 0.78999 YFEED= 0.90603 HFEED= 0.22172456E 06 TFEED=-286.96240

MINIMUM REFLUX = 0.63745 REFLUX RATIO= 0.70120

THE FRACTION DISTILLATE VAPORIZED= 0.0007

TEMPERATURES---DEGREES FAHRENHEIT

TOP	BOTTOM	FEED	CONDENSER
-289.67944	-284.82056	-286.96240	-290.21606

PRESSURES---PSIA

PTOP= 73.80000 PBOTTOM= 75.00000

PASS NUMBER 2

THE VALUE OF THE REFLUX RATIO= 0.70120

STAGE	TEMPERATURE DEGREES F	LIQUID RATE MOLES/HR.	VAPOR RATE MOLES/HR.	PRESSURE PSIA
COND.	-290.21606	85.05971	0.00000	73.50000
1	-289.67944	34.90472	85.05971	73.80000
2	-289.20972	34.52682	84.90474	73.89999
3	-288.76196	34.39322	84.52681	73.99998
4	-288.34839	34.19337	84.39325	74.09998
5	-287.97998	34.02261	84.19322	74.19997
6	-287.66113	33.94830	84.02267	74.29996
7	-287.38867	33.69162	83.94812	74.39995
8	-287.16724	33.64117	83.69150	74.49994
9	-286.98315	33.47137	83.64120	74.59993
10	-286.83618	33.54501	83.47134	74.69992
11	-286.70947	33.48264	83.54491	74.79991
12	-286.60547	133.55978	83.47589	74.89990
13	-286.26709	133.10303	83.55968	74.99989
REB. 14	-285.32739	50.00005	83.10312	75.09988

STAGE	X(1)	Y(1)
1	0.9505087	0.9799909
2	0.9218869	0.9678707
3	0.8953639	0.9562570
4	0.8715686	0.9455024
5	0.8510251	0.9359576
6	0.8338265	0.9277697
7	0.8196422	0.9208828
8	0.8086179	0.9154395
9	0.7998692	0.9110632
10	0.7933309	0.9077635
11	0.7879876	0.9050432
12	0.7839639	0.9029832
13	0.7667707	0.8940374
REB. 14	0.7173544	0.8671048

PASS	REFLUX RATIO	BOTTOMS COMP.
3	0.63108	0.8147993
4	0.77132	0.4868704
5	0.71207	0.6760574
6	0.73879	0.5804196
7	0.72937	0.6110585
8	0.73343	0.5988229
9	0.73222	0.6027896
10	0.73294	0.6000825

FINAL CONVERGENCE ACHIEVED ON BOTTOMS

COMPOSITION ---TOWER NUMBER 1

THE FEED IS INTRODUCED BETWEEN STAGES 11 AND 12

RLQW= 0.63108 R= 0.73294 RHIGH= 0.77132

STAGE	TEMPERATURE DEGREES F	PRESSURE PSIA	LIQUID RATE MOLES/HR.	VAPOR RATE MOLES/HR.	X(COMP.1)	Y(COMP.1)
COND.	-290.21606	73.50000	49.99995	0.00000	0.97999	0.99205
1	-289.67944	73.80000	36.44078	86.64709	0.95051	0.97999
2	-289.19873	73.89999	36.22591	86.44073	0.92117	0.96756
3	-288.72729	73.99998	35.78514	86.22601	0.89318	0.95528
4	-288.28735	74.09998	35.61053	85.78525	0.86781	0.94378
5	-287.88794	74.19997	35.36249	85.61038	0.84546	0.93333
6	-287.53906	74.29996	35.25792	85.36230	0.82656	0.92426
7	-287.23877	74.39995	35.04657	85.25792	0.81085	0.91654
8	-286.99023	74.49994	35.15302	85.04649	0.79835	0.91029
9	-286.77539	74.59993	35.06006	85.15292	0.78793	0.90500
10	-286.59912	74.69992	34.90157	85.06000	0.77981	0.90083
11	-286.45898	74.79991	34.81210	84.90155	0.77378	0.89770
12	-286.34521	74.89990	134.46739	84.80545	0.76927	0.89535
13	-285.43994	74.99989	132.94766	84.46738	0.72155	0.86946
REB. 14	-282.98364	75.09988	50.00005	82.94757	0.60008	0.79482

ENTHALPY BALANCE (BTU/HR.)

FEED ENTHALPY= 0.22172456E 06 REBILIER DUTY= 0.18321863E 06

TOTAL ENTHALPY IN = 0.40494319E 06

DISTILLATE ENTHALPY = 0.10823056E 06 BOTTOMS ENTHALPY = 0.11386025E 06 CONDENSER DUTY =-0.18285238E 06

TOTAL ENTHALPY OUT = 0.40494319E 06

TOWER NUMBER 1 IS COMPLETE

_COLUMN_NUMBER_---2-----PROBLEM NUMBER

AIR PLANT---D(1)=REFLUX(2)

-----*****CONSTIANIS*****-----IQWB_NUMBER_2-----

	EQUILIBRIUM	PRESSURE	ENTHALPY-LIQUID	ENTHALPY-VAPOR
A1	12.24675	14.70000	-3444.33690	2182.85660
B1	-1330.35910	14.70000	34.13612	12.80102
A2	10.54674	14.70000	-3149.98040	2393.01070
B2	-1279.70550	14.70000	32.48738	16.24368

INPUT DATA USED IN CALCULATIONS

FEED RATE MOLS/HOUR	XF(1)	XB(1)	DIST.RATE MOLS/HOUR	DIST.SPLIT	ZD(1)
50.00003	.600082	.010000	30.10622	0.00000	.990000

PRESSURE DROP/STAGE=0.1000 CONDENSER PRESSURE DROP=0.3000 REBOILER PRESSURE DROP=0.1000

FLASHED FEED

THE FRACTION FEED VAPORIZED= 0.2438

XFEED= 0.53082 YFEED= 0.81494 HFEED= 0.11378713E 06 TFEED=-311.45361

AIR PLANT---SECOND COLUMN---ABSORBER SECTION

STAGE	TEMPERATURE DEGREES F	PRESSURE PSIA	LIQUID RATE MOLES/HR.	VAPOR RATE MOLES/HR.	X(COMP.1)	Y(COMP.1)
REB.	-290.58301	20.09999	20.45335	44.77570	0.01000	0.01000
2	-291.19800	20.00000	65.22905	44.16626	0.01000	0.03935
3	-292.57813	19.89999	64.61961	43.36884	0.03006	0.11139
4	-295.40796	19.79999	63.82219	42.54596	0.07889	0.25632
5	-299.82837	19.69998	62.99931	42.25026	0.17635	0.46070
6	-304.44556	19.59998	62.70361	42.97437	0.31369	0.64370
7	-307.70435	19.49997	63.42772	43.57489	0.43936	0.75466
8	-309.43457	19.39996	64.02824	43.16164	0.51679	0.80702
9	-310.72705	19.29996	25.80382	55.62257	0.57999	0.84336
10	-312.13257	19.19995	26.07591	55.94418	0.65617	0.88120
11	-313.50903	19.09995	26.39746	56.47319	0.73864	0.91631
12	-314.68335	18.99994	26.92656	56.94569	0.81509	0.94455
13	-315.56641	18.89993	27.39900	57.39355	0.87552	0.96443
14	-316.17676	18.79993	27.84702	57.47720	0.91760	0.97720
15	-316.57935	18.69992	27.93033	57.58319	0.94403	0.98483
16	-316.84912	18.59991	28.03665	57.65257	0.95981	0.98922
TOP 17	-317.03809	18.49991	28.10562	57.82990	0.96890	0.99173

REVISED VALUES BASED ON TRUE PRESSURE PROFILE

TRIAL NUMBER 2
THE FEED IS INTRODUCED BETWEEN STAGES 8 AND 9

INPUT DATA USED IN CALCULATIONS

FEED RATE MOLS/HOUR	XF(1)	XB(1)	DIST.RATE MOLS/HOUR	DIST.SPLIT	Z0(1)
50.00002	.600082	.010000	30.10620	0.00000	.990000

FLASHED FEED

THE FRACTION FEED VAPORIZED= 0.2258

XFEED= 0.53631 YFEED= 0.81880 HFEED= 0.11379119E 06 TFEED=-309.81860

AIR PLANT---SECOND COLUMN---ABSORBER SECTION

STAGE	TEMPERATURE DEGREES F	PRESSURE PSIA	LIQUID RATE MOLES/HR.	VAPOR RATE MOLES/HR.	X(COMP.1)	Y(COMP.1)
REB.	-290.58301	20.09999	20.45212	44.77692	0.01000	0.01000
2	-291.19800	20.00000	65.22903	44.16626	0.01000	0.03935
3	-292.57813	19.89999	64.61838	43.36945	0.03006	0.11139
4	-295.40796	19.79999	63.82159	42.54588	0.07890	0.25632
5	-299.82886	19.69998	62.99802	42.25092	0.17636	0.46071
6	-304.44604	19.59998	62.70303	42.97536	0.31370	0.64372
7	-307.70483	19.49997	63.42747	43.57590	0.43938	0.75468
8	-309.43506	19.39996	64.02802	43.95508	0.51681	0.80703
9	-310.73633	19.29996	25.69504	55.61357	0.58051	0.84364
10	-312.14209	19.19995	26.06569	55.94432	0.65674	0.88145
11	-313.51758	19.09995	26.39638	56.46870	0.73922	0.91655
12	-314.69067	18.99994	26.92081	56.94894	0.81561	0.94472
13	-315.57129	18.89993	27.40129	57.39001	0.87592	0.96457
14	-316.18066	18.79993	27.84200	57.47438	0.91792	0.97730
15	-316.58228	18.69992	27.92639	57.58716	0.94427	0.98489
16	-316.85107	18.59991	28.03926	57.65076	0.95999	0.98928
17	-317.04004	18.49991	28.10318	57.84618	0.96905	0.99175
TOP 18	-317.18359	18.39990	28.29810	57.69617	0.97425	0.99316

PRESSURE VARIATIONS HAVE BEEN DAMPED

TRIAL	OVERHEAD FEED REQUIRED	OVERHEAD FEED ACTUAL	CONDENSER DUTY(1)	REBOILER DUTY(2)
2	35,8200070	28,1484060	0,1828524E 06	0,1828524E 06
3	35,8200070	40,1277160	0,1828524E 06	0,2136609E 06
4	35,8200070	35,1592100	0,1828524E 06	0,2007569E 06
5	35,8200070	36,8414610	0,1828524E 06	0,2051918E 06
6	35,8200070	36,1804650	0,1828524E 06	0,2030937E 06

THE SECOND TOWER IS INDEPENDENTLY CLOSED

THE FEED IS INTRODUCED BETWEEN STAGES 8 AND 9

STAGE	TEMPERATURE DEGREES F	PRESSURE PSIA	LIQUID RATE MOLES/HR.	VAPOR RATE MOLES/HR.	X(COMP.1)	Y(COMP.1)
REB.	-290.58301	20.09999	20.45212	51.99762	0.01000	0.01000
2	-291.19800	20.00000	72.44974	51.42238	0.01000	0.03935
3	-292.63477	19.89999	71.87450	50.43419	0.03100	0.11455
4	-295.68652	19.79999	70.88632	49.31038	0.08439	0.27043
5	-300.49683	19.69998	69.76250	49.42889	0.19408	0.48969
6	-305.41821	19.59998	69.88101	50.32549	0.34930	0.67923
7	-308.71362	19.49997	70.77760	51.23323	0.48585	0.78727
8	-310.37329	19.39996	71.68533	45.03790	0.56551	0.83549
9	-311.73584	19.29996	26.77785	56.81207	0.63753	0.87249
10	-313.22046	19.19995	27.26418	64.09064	0.72506	0.91090
11	-314.76733	19.09995	34.54268	64.64423	0.82740	0.94876
12	-315.77393	18.99994	35.09659	65.08287	0.89845	0.97151
13	-316.37500	18.89993	35.53482	65.50285	0.94074	0.98390
14	-316.72949	18.79993	35.95555	65.51746	0.96368	0.99029
15	-316.94751	18.69992	35.96947	65.42711	0.97532	0.99346
16	-317.09619	18.59991	35.87918	65.48859	0.98107	0.99501
17	-317.21143	18.49991	35.94066	65.57368	0.98391	0.99578
TOP 18	-317.31104	18.39990	36.02478	65.72682	0.98533	0.99614

----- ENTHALPY BALANCE (BTU/HR.) -----

FEED ENTHALPY= 0.11386025E 06 REBOILER DUTY= 0.20309369E 06 REFLUX ENTHALPY= 0.51528977E 05

TOTAL ENTHALPY IN = 0.36848288E 06

BOTTOMS ENTHALPY 0.10506306E 06 TOP PRODUCT ENTHALPY 0.26370438E 06

TOTAL ENTHALPY OUT = 0.36876744E 06

----- TOWER NUMBER TWO IS COMPLETE -----

----- COLUMN NUMBER 1 ===== PROBLEM NUMBER 1 -----

FEED RATE MOLS/HOUR	XF(1)	XB(1)	DIST.RATE MOLS/HOUR	DIST.SPLIT	ZD(1)
100.00000	.790000	.600000	49.99995	0.00000	.980000

PRESSURE DROP/STAGE=0.1000 CONDENSER PRESSURE DROP=0.3000 REBOILER PRESSURE DROP=0.1000

BUBBLE POINT FEED

THE FRACTION FEED VAPORIZED= 0.0001

XFEED= 0.78999 YFEED= 0.90604 HFEED= 0.22186631E 06 TFEED=-286.87842

MINIMUM REFLUX = 0.63727 REFLUX RATIO= 0.92451

THE FRACTION DISTILLATE VAPORIZED= 0.0007

TEMPERATURES---DEGREES FAHRENHEIT

TOP	BOTTOM	FEED	CONDENSER
-289.67944	-284.62056	-286.87842	-290.21606

PRESSURES---PSIA

PTOP= 73.80000 PBOTTOM= 75.00000

FIRST PASS---DETERMINATION OF NUMBER OF STAGES

RECTIFYING SECTION

STAGE	TEMPERATURE DEGREES F	LIQUID RATE MOLES/HR.	VAPOR RATE MOLES/HR.	PRESSURE PSIA
COND.	-290.21606	49.99995	0.00000	73.50000
1	-289.67944	46.03233	96.22549	73.80000
2	-289.13745	45.50606	96.03291	73.89999
3	-288.54321	45.20465	95.50630	73.99998
4	-287.91992	44.75742	95.20457	74.09998
5	-287.30127	44.41364	94.75739	74.19997

THE NET VAPOR ENTERING THE RECTIFYING SECTION IS 94.41357

STAGE	X(1)	Y(1)
1	0.9505087	0.9799909
2	0.9172261	0.9658588
3	0.8816244	0.9500852
4	0.8453791	0.9332849
5	0.8105946	0.9164088

THE NUMBER OF STAGES IN THE RECTIFYING SECTION ARE 5

STRIPPING SECTION

STAGE	TEMPERATURE DEGREES F	LIQUID RATE MOLES/HR.	VAPOR RATE MOLES/HR.	PRESSURE PSIA
6	-286.55273	144.08479	94.50697	74.89998
7	-285.69678	142.24242	94.08473	74.99998
REB. 8	-282.98193	50.00005	92.24237	75.09999

THE NET LIQUID ENTERING THE STRIPPING SECTION IS 144.50702

STAGE	X(1)	Y(1)
6	0.7809684	0.9014373
7	0.7353791	0.8771416
REB. 8	0.6000000	0.8087614

THE NUMBER OF STAGES IN THE STRIPPING SECTION ARE 3

THE TOTAL NUMBER OF STAGES IN TOWER ARE 8

PASS NUMBER 1 IS COMPLETE

REVISED VALUES BASED ON TRUE PRESSURE PROFILE

BUBBLE POINT FEED

THE FRACTION FEED VAPORIZED= 0.0000

XFEED= 0.79000 YFEED= 0.90603 HFEED= 0.22166063E 06 TFEED=-286,99609

MINIMUM REFLUX = 0.63752 REFLUX RATIO= 0.92487

THE FRACTION DISTILLATE VAPORIZED= 0.0007

TEMPERATURES---DEGREES FAHRENHEIT

TOP	BOTTOM	FEED	CONDENSER
-289.67944	-285.69678	-286.99609	-290.21606

PRESSURES---PSIA

PTOP= 73.80000	PBOTTOM= 74.39999
----------------	-------------------

PASS NUMBER 2

THE VALUE OF THE REFLUX RATIO= 0.92487

STAGE	TEMPERATURE DEGREES F	LIQUID RATE MOLES/HR.	VAPOR RATE MOLES/HR.	PRESSURE PSIA
COND.	-290.21606	96.24353	0.00000	73.50000
1	-289.67944	46.04573	96.24353	73.80000
2	-289.13745	45.52342	96.04535	73.89999
3	-288.54297	45.21733	95.52313	73.99998
4	-287.91943	44.77368	95.21741	74.09998
5	-287.30054	44.42981	94.77353	74.19997
6	-286.71509	44.08714	94.42984	74.29996
7	-286.18823	142.92807	94.08455	74.39995
REB. 8	-284.39893	50.00005	92.92810	74.49994

STAGE	X(1)	Y(1)
1	0.9505087	0.9799910
2	0.9172242	0.9658567
3	0.8816087	0.9500784
4	0.8453494	0.9332706
5	0.8105475	0.9163826
6	0.7787657	0.9002667
7	0.7511740	0.8857007
REB. 8	0.6587275	0.8325084

-----PASS NUMBER 2 IS COMPLETE-----

PASS	REFLUX RATIO	BOTTOMS COMP.
3	0.83239	0.7420707
4	1.01736	0.5885121
5	0.96420	0.6281107
6	0.99636	0.6051644
7	1.00486	0.5989576
8	1.00202	0.6006418
9	1.00327	0.5998993
10	1.00287	0.6001325
11	1.00309	0.6000246

FINAL CONVERGENCE ACHIEVED ON BOTTOMS

COMPOSITION ---TOWER NUMBER 1

THE FEED IS INTRODUCED BETWEEN STAGES 6 AND 7

RLOW= 0.83239 R= 1.00309 RHIGH= 1.01736

STAGE	TEMPERATURE DEGREES F	PRESSURE PSIA	LIQUID RATE MOLES/HR.	VAPOR RATE MOLES/HR.	X(COMP.1)	Y(COMP.1)
COND.	-290.21606	73.50000	49.99995	0.00000	0.97999	0.99205
1	-289.67944	73.80000	49.78699	100.15421	0.95051	0.97999
2	-289.11694	73.89999	49.42500	99.78674	0.91590	0.96528
3	-288.47412	73.99998	48.93660	99.42522	0.87732	0.94813
4	-287.77783	74.09998	48.53621	98.93628	0.83683	0.92921
5	-287.06323	74.19997	47.82237	98.53607	0.79676	0.90947
6	-286.38135	74.29996	47.40067	97.82228	0.76000	0.89042
7	-285.76050	74.39995	145.56458	97.39795	0.72784	0.87293
REB. 8	-283.19263	74.49994	50.00005	95.56448	0.60002	0.79471

ENTHALPY BALANCE (BTU/HR.)

FEED ENTHALPY= 0.22166063E 06 REBOILER DUTY= 0.21162094E 06

TOTAL ENTHALPY IN = 0.43328156E 06

DISTILLATE ENTHALPY = 0.10823056E 06 BOTTOMS ENTHALPY = 0.11369438E 06 CONDENSER DUTY =-0.21135663E 06

TOTAL ENTHALPY OUT = 0.43328156E 06

TOWER NUMBER 1 IS COMPLETE

_COLUMN_NUMBER_...2-----PROBLEM NUMBER

INPUT DATA USED IN CALCULATIONS

FEED RATE MOLS/HOUR	XF(1)	XB(1)	DIST.RATE MOLS/HOUR	DIST.SPLIT	ZD(1)
50.00005	.600024	.010000	30.10329	0.00000	.990000

PRESSURE DROP/STAGE=0.1000 CONDENSER PRESSURE DROP=0.3000 REBOILER PRESSURE DROP=0.1000

FLASHED FEED

THE FRACTION FEED VAPORIZED= 0.2259

XFEED= 0.53620 YFEED= 0.81869 HFEED= 0.11362550E 06 TFEED=-309.94897

AIR PLANT---SECOND COLUMN---ABSORBER SECTION

STAGE	TEMPERATURE DEGREES F	PRESSURE PSIA	LIQUID RATE MOLES/HR.	VAPOR RATE MOLES/HR.	X(COMP.1)	Y(COMP.1)
REB.	-290.58301	20.09999	20.45505	54.94234	0.01000	0.01000
2	-291.19800	20.00000	75.39738	54.33238	0.01000	0.03935
3	-292.65454	19.89999	74.78745	53.28462	0.03132	0.11564
4	-295.78418	19.79999	73.73965	52.19554	0.08634	0.27535
5	-300.73657	19.69998	72.65059	52.27937	0.20064	0.49992
6	-305.75342	19.59998	72.73444	53.44038	0.36214	0.69116
7	-309.05981	19.49997	73.89543	54.31499	0.50260	0.79817
8	-311.56104	19.39996	36.06630	66.58156	0.63228	0.86998
9	-313.64771	19.29996	37.03658	67.38399	0.75947	0.92441
10	-315.10083	19.19995	37.83922	68.15723	0.85873	0.95912
11	-315.97559	19.09995	38.61220	68.33130	0.92132	0.97832
12	-316.46704	18.99994	38.78647	68.53201	0.95531	0.98800
TOP 13	-316.75000	18.89993	38.98763	68.74455	0.97244	0.99269

REVISED VALUES BASED ON TRUE PRESSURE PROFILE

TRIAL NUMBER 2
THE FEED IS INTRODUCED BETWEEN STAGES 7 AND 8

INPUT DATA USED IN CALCULATIONS

FEED RATE MOLS/HOUR	XF(1)	XB(1)	DIST.RATE MOLS/HOUR	DIST.SPLIT	ZD(1)
50.00003	.600024	.010000	30.10327	0.00000	.990000

FLASHED FEED

THE FRACTION FEED VAPORIZED= 0.2238

XFEED= 0.53686 YFEED= 0.81915 HFEED= 0.11364594E 06 TFEED=-309.74146

AIR PLANT---SECOND COLUMN---ABSORBER SECTION

STAGE	TEMPERATURE DEGREES F	PRESSURE PSIA	LIQUID RATE MOLES/HR.	VAPOR RATE MOLES/HR.	X(COMP.1)	Y(COMP.1)
REB.	-290.58301	20.09999	20.45482	54.94257	0.01000	0.01000
2	-291.19800	20.00000	75.39738	54.33247	0.01000	0.03935
3	-292.65454	19.89999	74.78729	53.28482	0.03132	0.11564
4	-295.78418	19.79999	73.73964	52.19566	0.08634	0.27536
5	-300.73682	19.69998	72.65048	52.27979	0.20064	0.49992
6	-305.75342	19.59998	72.73460	53.44037	0.36214	0.69116
7	-309.06006	19.49997	73.89519	54.41493	0.50261	0.79816
8	-311.56177	19.39996	36.05775	66.58514	0.63232	0.87000
9	-313.64819	19.29996	37.03995	67.38974	0.75951	0.92442
10	-315.10132	19.19995	37.84465	68.15680	0.85877	0.95914
11	-315.97607	19.09995	38.61174	68.33745	0.92136	0.97832
12	-316.46729	18.99994	38.79172	68.53700	0.95533	0.98800
TOP 13	-316.75024	18.89993	38.99133	68.75125	0.97246	0.99270

PRESSURE VARIATIONS HAVE BEEN DAMPED

TRIAL	OVERHEAD FEED REQUIRED	OVERHEAD FEED ACTUAL	CONDENSER DUTY(1)	REBOILER DUTY(2)
2	36.0231470	39.2046660	0.2113566E 06	0.2113566E 06
3	36.0231470	33.9294730	0.2113566E 06	0.1985559E 06
4	36.0231470	36.3501890	0.2113566E 06	0.2042268E 06

THE SECOND TOWER IS INDEPENDENTLY CLOSED

THE FEED IS INTRODUCED BETWEEN STAGES 7 AND 8

STAGE	TEMPERATURE DEGREES F	PRESSURE PSIA	LIQUID RATE MOLES/HR.	VAPOR RATE MOLES/HR.	X(COMP.1)	Y(COMP.1)
REB.	-290.58301	20.09999	20.45482	52.39912	0.01000	0.01000
2	-291.19800	20.00000	72.85394	51.78123	0.01000	0.03935
3	-292.63745	19.89999	72.23605	50.74197	0.03104	0.11469
4	-295.69775	19.79999	71.19678	49.62656	0.08461	0.27100
5	-300.52417	19.69998	70.08138	49.79440	0.19482	0.49085
6	-305.45898	19.59998	70.24922	50.69958	0.35084	0.68068
7	-308.75610	19.49997	71.15440	44.67940	0.48788	0.78862
8	-310.17188	19.39996	26.32222	56.22177	0.55478	0.82949
9	-311.62891	19.29996	26.67657	63.86600	0.63122	0.86945
10	-313.58911	19.19995	34.32079	64.74648	0.74974	0.92065
11	-315.02808	19.09995	35.20125	65.28133	0.84691	0.95526
12	-315.93335	18.99994	35.73651	65.51003	0.91124	0.97534
TOP 13	-316.46289	18.89993	35.96489	65.89551	0.94808	0.98597

-----ENTHALPY BALANCE (BTU/HR.)-----

FEED ENTHALPY= 0.11369438E 06 REBOILER DUTY= 0.20422675E 06 REFLUX ENTHALPY= 0.52586332E 05

TOTAL ENTHALPY IN = 0.37050744E 06

BOTTOMS ENTHALPY 0.10507694E 06 TOP PRODUCT ENTHALPY 0.26556913E 06

TOTAL ENTHALPY OUT = 0.37064606E 06

-----TOWER_NUMBER_IWD_IS_COMPLETE-----

-----COLUMN_NUMBER-----1=====PROBLEM_NUMBER-----1-----

FEED RATE MOLS/HOUR	XF(1)	XB(1)	DIST.RATE MOLS/HOUR	DIST.SPLIT	ZD(1)
100.00000	.790000	.610000	48.64864	0.00000	.980000

PRESSURE DROP/STAGE=0.1000 CONDENSER PRESSURE DROP=0.3000 REBOILER PRESSURE DROP=0.1000

BUBBLE POINT FEED

THE FRACTION FEED VAPORIZED= 0.0000

XFEED= 0.79000 YFEED= 0.90603 HFEED= 0.22169163E 06 TFEED=-286.97925

MINIMUM REFLUX = 0.63748 REFLUX RATIO= 0.92482

THE FRACTION DISTILLATE VAPORIZED= 0.0007

TEMPERATURES---DEGREES FAHRENHEIT

TOP	BOTTOM	FEED	CONDENSER
-289.67944	-285.69678	-286.97925	-290.21606

PRESSURES---PSIA

PTOP= 73.80000 PBOTTOM= 74.39999

FIRST PASS---DETERMINATION OF NUMBER OF STAGES

RECTIFYING SECTION

STAGE	TEMPERATURE DEGREES F	LIQUID RATE MOLES/HR.	VAPOR RATE MOLES/HR.	PRESSURE PSIA
COND.	-290.21606	48.64864	0.00000	73.50000
1	-289.67944	44.80084	93.64000	73.80000
2	-289.13721	44.28928	93.44917	73.89999
3	-288.54297	43.99583	92.93791	73.99998
4	-287.91943	43.56161	92.64436	74.09998
5	-287.30054	43.22647	92.21024	74.19997

THE NET VAPOR ENTERING THE RECTIFYING SECTION IS 91.87506

STAGE	X(1)	Y(1)
1	0.9505087	0.9799910
2	0.9172151	0.9658568
3	0.8816059	0.9500753
4	0.8453479	0.9332690
5	0.8105482	0.9163834

THE NUMBER OF STAGES IN THE RECTIFYING SECTION ARE 5

STRIPPING SECTION

STAGE	TEMPERATURE DEGREES F	LIQUID RATE MOLES/HR.	VAPOR RATE MOLES/HR.	PRESSURE PSIA
6	-286.76025	142.62903	91.90302	74.29997
7	-285.92139	141.06412	91.27766	74.39998
REB. 8	-283.40308	51.35136	89.71275	74.49998

THE NET LIQUID ENTERING THE STRIPPING SECTION IS 143,25438

STAGE	X(1)	Y(1)
6	0.7813481	0.9016141
7	0.7365482	0.8777458
REB. 8	0.6100000	0.8089840

THE NUMBER OF STAGES IN THE STRIPPING SECTION ARE 3

THE TOTAL NUMBER OF STAGES IN TOWER ARE 8

PASS NUMBER 1 IS COMPLETE

REVISED VALUES BASED ON TRUE PRESSURE PROFILE

BUBBLE POINT FEED

THE FRACTION FEED VAPORIZED= 0.0000

XFEED= 0.79000 YFEED= 0.90603 HFEED= 0.22166063E 06 TFEED=-286.99609

MINIMUM REFLUX = 0.63752 REFLUX RATIO= 0.92487

THE FRACTION DISTILLATE VAPORIZED= 0.0007

TEMPERATURES---DEGREES FAHRENHEIT

TOP	BOTTOM	FEED	CONDENSER
-289.67944	-285.92139	-286.99609	-290.21606

PRESSURES---PSIA

PTOP= 73.80000 PBOTTOM= 74.39999

PASS NUMBER 2

THE VALUE OF THE REFLUX RATIO= 0.92487

STAGE	TEMPERATURE DEGREES F	LIQUID RATE MOLES/HR.	VAPOR RATE MOLES/HR.	PRESSURE PSIA
COND.	-290.21606	93.64241	0.00000	73.50000
1	-289.67944	44.80200	93.64241	73.80000
2	-289.13745	44.29147	93.45053	73.89999
3	-288.54297	43.99529	92.94026	73.99998
4	-287.91943	43.56296	92.64397	74.09998
5	-287.30054	43.22844	92.21156	74.19997
6	-286.71509	42.89503	91.87708	74.29996
7	-286.18848	141.75359	91.54105	74.39995
REB. 8	-284.36206	51.35136	90.40222	74.49994

STAGE	X(1)	Y(1)
1	0.9505086	0.9799908
2	0.9172240	0.9658566
3	0.8816091	0.9500788
4	0.8453496	0.9332709
5	0.8105480	0.9163832
6	0.7787664	0.9002675
7	0.7511820	0.8857015
REB. 8	0.6568806	0.8313727

-----PASS NUMBER 2 IS COMPLETE-----

PASS REFLUX RATIO BOTTOMS COMP.

3 0.83239 0.7413213

4 1.01736 0.5858468

5 0.95675 0.6324053

6 0.98648 0.6099548

FINAL CONVERGENCE ACHIEVED ON BOTTOMS

COMPOSITION ---TOWER NUMBER 1

THE FEED IS INTRODUCED BETWEEN STAGES 6 AND 7

RLOW= 0.83239 R= 0.98648 RHIGH= 1.01736

STAGE	TEMPERATURE DEGREES F	PRESSURE PSIA	LIQUID RATE MOLES/HR.	VAPOR RATE MOLES/HR.	X(COMP.1)	Y(COMP.1)
COND.	-290.21606	73.50000	48.64864	0.00000	0.97999	0.99205
1	-289.67944	73.80000	47.62366	96.63976	0.95051	0.97999
2	-289.12134	73.89999	47.16379	96.27255	0.91619	0.96541
3	-288.48999	73.99998	46.78523	95.81218	0.87831	0.94858
4	-287.81030	74.09998	46.31546	95.43393	0.83878	0.93014
5	-287.11963	74.19997	45.83182	94.96405	0.80002	0.91112
6	-286.45801	74.29996	45.46831	94.48053	0.76429	0.89269
7	-285.85571	74.39995	143.71130	94.11440	0.73298	0.87578
REB.	-283.40210	74.49994	51.35136	92.36002	0.60995	0.80135

ENTHALPY BALANCE (BIU/HR.)

FEED ENTHALPY= 0.22166063E 06 REBOILER DUTY= 0.20419519E 06

TOTAL ENTHALPY IN = 0.42585581E 06

DISTILLATE ENTHALPY = 0.10530550E 06 BOTTOMS ENTHALPY = 0.11661031E 06 CONDENSER DUTY = -0.20394000E 06

TOTAL ENTHALPY OUT = 0.42585581E 06

TOWER NUMBER 1 IS COMPLETE

_COLUMN_NUMBER_ _2_-----PROBLEM NUMBER

INPUT DATA USED IN CALCULATIONS

FEED RATE MOLS/HOUR	XF(1)	XB(1)	DIST.RATE MOLS/HOUR	DIST.SPLIT	ZD(1)
51.35135	.609954	.010000	31.43719	0.00000	.990000

PRESSURE DROP/STAGE=0.1000 CONDENSER PRESSURE DROP=0.3000 REBILER PRESSURE DROP=0.1000

FLASHED FEED

THE FRACTION FEED VAPORIZED= 0.2261

XFEED= 0.54709 YFEED= 0.82510 HFEED= 0.11660025E 06 TFEED=-309.98218

AIR PLANT---SECOND COLUMN---ABSORBER SECTION

STAGE	TEMPERATURE DEGREES F	PRESSURE PSIA	LIQUID RATE MOLES/HR.	VAPOR RATE MOLES/HR.	X(COMP.1)	Y(COMP.1)
REB, 2	-290.58301	20.09999	20.45711	52.29456	0.01000	0.01000
3	-291.19800	20.00000	72.75166	51.68851	0.01000	0.03935
4	-292.63672	19.89999	72.14561	50.66341	0.03103	0.11465
5	-295.69458	19.79999	71.12050	49.54535	0.08455	0.27084
6	-300.51660	19.69998	70.00246	49.69952	0.19462	0.49053
7	-305.44775	19.59998	70.15663	50.60262	0.35041	0.68027
8	-308.74414	19.49997	71.05972	51.48041	0.48731	0.78824
9	-310.84692	19.39996	32.19862	63.77982	0.59143	0.84945
10	-312.76953	19.29996	32.88557	64.68266	0.70123	0.90107
11	-314.36401	19.19995	33.78835	65.23837	0.80401	0.94070
12	-315.46899	19.09995	34.34436	65.70796	0.88085	0.96612
13	-316.15894	18.99994	34.81355	65.95804	0.92964	0.98073
14	-316.57324	18.89993	35.06271	66.23790	0.95738	0.98857
TOP 14	-316.82983	18.79993	35.34328	66.30322	0.97226	0.99264

REVISED VALUES BASED ON TRUE PRESSURE PROFILE

TRIAL NUMBER 2
THE FEED IS INTRODUCED BETWEEN STAGES 7 AND 8

INPUT DATA USED IN CALCULATIONS

FEED RATE MOLS/HOUR	XF(1)	XB(1)	DIST.RATE MOLS/HOUR	DIST.SPLIT	ZD(1)
51.35133	.609954	.010000	31.43718	0.00000	.990000

FLASHED FEED

THE FRACTION FEED VAPORIZED= 0.2257

XFEED= 0.54723 YFEED= 0.82519 HFEED= 0.11659838E 06 TFEED=-309.94116

AIR PLANT---SECOND COLUMN---ABSORBER SECTION

STAGE	TEMPERATURE DEGREES F	PRESSURE PSIA	LIQUID RATE MOLES/HR.	VAPOR RATE MOLES/HR.	X(COMP.1)	Y(COMP.1)
REB.	-290.58301	20.09999	20.45718	52.29448	0.01000	0.01000
2	-291.19800	20.00000	72.75166	51.68848	0.01000	0.03935
3	-292.63672	19.89999	72.14566	50.66336	0.03103	0.11465
4	-295.69458	19.79999	71.12056	49.54538	0.08455	0.27084
5	-300.51636	19.69998	70.00256	49.69934	0.19462	0.49053
6	-305.44775	19.59998	70.15652	50.60252	0.35041	0.68028
7	-308.74414	19.49997	71.05971	51.50160	0.48731	0.78825
8	-310.84668	19.39996	32.19557	63.77882	0.59142	0.84945
9	-312.76953	19.29996	32.88469	64.68185	0.70123	0.90107
10	-314.36426	19.19995	33.78783	65.23860	0.80401	0.94069
11	-315.46899	19.09995	34.34456	65.71259	0.88084	0.96610
12	-316.15862	18.99994	34.81844	65.95798	0.92962	0.98072
13	-316.57300	18.89993	35.06387	66.23743	0.95736	0.98856
TOP 14	-316.82959	18.79993	35.34352	66.30034	0.97224	0.99263

PRESSURE VARIATIONS HAVE BEEN DAMPED

TRIAL	OVERHEAD FEED REQUIRED	OVERHEAD FEED ACTUAL	CONDENSER DUTY(1)	REBOILER DUTY(2)
2	35.0033720	35.4070580	0.2039400E 06	0.2039400E 06

THE SECOND TOWER IS INDEPENDENTLY CLOSED

THE FEED IS INTRODUCED BETWEEN STAGES 7 AND 8

STAGE	TEMPERATURE DEGREES F	PRESSURE PSIA	LIQUID RATE MOLES/HR.	VAPOR RATE MOLES/HR.	X(COMP.1)	Y(COMP.1)
REB.	-290.58301	20.09999	20.45718	52.29448	0.01000	0.01000
2	-291.19800	20.00000	72.75166	51.68848	0.01000	0.03935
3	-292.63672	19.89999	72.14566	50.66336	0.03103	0.11465
4	-295.69458	19.79999	71.12056	49.54538	0.08455	0.27084
5	-300.51636	19.69998	70.00256	49.69934	0.19462	0.49053
6	-305.44775	19.59998	70.15652	50.60252	0.35041	0.68028
7	-308.74414	19.49997	71.05971	51.50160	0.48731	0.78825
8	-310.84668	19.39996	32.19557	63.77882	0.59142	0.84945
9	-312.76953	19.29996	32.88469	64.68185	0.70123	0.90107
10	-314.36426	19.19995	33.78783	65.23860	0.80401	0.94069
11	-315.46899	19.09995	34.34456	65.71259	0.88084	0.96610
12	-316.15869	18.99994	34.81844	65.95798	0.92962	0.98072
13	-316.57300	18.89993	35.06387	66.23743	0.95736	0.98856
TOP 14	-316.82959	18.79993	35.34352	66.30034	0.97224	0.99263

-----ENTHALPY BALANCE (BTU/HR.)-----

FEED ENTHALPY= 0.11661031E 06 REBILIER DUTY= 0.20394000E 06 REFLUX ENTHALPY= 0.50925895E 05

TOTAL ENTHALPY IN = 0.37147619E 06

BOTTOMS ENTHALPY 0.10508906E 06 TOP PRODUCT ENTHALPY 0.26657800E 06

TOTAL ENTHALPY OUT = 0.37166706E 06

-----TOWER NUMBER TWO IS COMPLETE-----

FINAL CONVERGENCE HAS BEEN ACHIEVED FOR BOTH TOWERS

----- COLUMN NUMBER --- 1 ----- PROBLEM NUMBER -----

FEED RATE MOLS/HOUR	XF(1)	XB(1)	DIST,RATE MOLS/HOUR	DIST,SPLIT	ZD(1)
100.00000	.790000	.610000	48.64864	0.00000	.980000

PRESSURE DROP/STAGE=0.1000 CONDENSER PRESSURE DROP=0.3000 REBOILER PRESSURE DROP=0.1000

BUBBLE POINT FEED

THE FRACTION FEED VAPORIZED= 0.0002

XFEED= 0.78998 YFEED= 0.90602 HFEED= 0.22171769E 06 TFEED=-286.97900

MINIMUM REFLUX = 0.63751 REFLUX RATIO= 0.92486

THE FRACTION DISTILLATE VAPORIZED= 0.0007

TEMPERATURES---DEGREES FAHRENHEIT

TOP	BOTTOM	FEED	CONDENSER
-289.67944	-285.92139	-286.97900	-290.21606

PRESSURES---PSIA

PTOP= 73.80000 PBOTTOM= 74.39999

FIRST PASS---DETERMINATION OF NUMBER OF STAGES

RECTIFYING SECTION

STAGE	TEMPERATURE DEGREES F	LIQUID RATE MOLES/HR.	VAPOR RATE MOLES/HR.	PRESSURE PSIA
COND.	-290.21606	48.64864	0.00000	73.50000
1	-289.67944	44.80200	93.64157	73.80000
2	-289.13745	44.29053	93.45053	73.89999
3	-288.54297	43.99449	92.93924	73.99998
4	-287.91943	43.56206	92.64325	74.09998
5	-287.30054	43.22775	92.21059	74.19997

THE NET VAPOR ENTERING THE RECTIFYING SECTION IS 91.87637

STAGE	X(1)	Y(1)
1	0.9505086	0.9799908
2	0.9172240	0.9658566
3	0.8816094	0.9500791
4	0.8453500	0.9332714
5	0.8105488	0.9163841

THE NUMBER OF STAGES IN THE RECTIFYING SECTION ARE 5

STRIPPING SECTION

STAGE	TEMPERATURE DEGREES F	LIQUID RATE MOLES/HR.	VAPOR RATE MOLES/HR.	PRESSURE PSIA
6	-286.76050	142.61810	91.89395	74.29997
7	-285.92114	141.05507	91.26672	74.39998
REB. 8	-283.40308	51.35136	89.70370	74.49998

THE NET LIQUID ENTERING THE STRIPPING SECTION IS 143.24532

STAGE	X(1)	Y(1)
6	0.7813430	0.9015993
7	0.7365435	0.8777494
REB. 8	0.6100000	0.8089840

THE NUMBER OF STAGES IN THE STRIPPING SECTION ARE 3

THE TOTAL NUMBER OF STAGES IN TOWER ARE 8

PASS NUMBER 1 IS COMPLETE

REVISED VALUES BASED ON TRUE PRESSURE PROFILE

BUBBLE POINT FEED

THE FRACTION FEED VAPORIZED= 0.0000

XFEED= 0.79000 YFEED= 0.90603 HFEED= 0.22166063E 06 TFEED=-286.99609

MINIMUM REFLUX = 0.63752 REFLUX RATIO= 0.92487

THE FRACTION DISTILLATE VAPORIZED= 0.0007

TEMPERATURES---DEGREES FAHRENHEIT

TOP	BOTTOM	FEED	CONDENSER
-289.67944	-285.92114	-286.99609	-290.21606

PRESSURES---PSIA

PTOP= 73.80000 PBOTTOM= 74.39999

PASS NUMBER 2

THE VALUE OF THE REFLUX RATIO= 0.92487

STAGE	TEMPERATURE DEGREES F	LIQUID RATE MOLES/HR.	VAPOR RATE MOLES/HR.	PRESSURE PSIA
COND.	-290.21606	93.64241	0.00000	73.50000
1	-289.67944	44.80200	93.64241	73.80000
2	-289.13745	44.29147	93.45053	73.89999
3	-288.54297	43.99529	92.94026	73.99998
4	-287.91943	43.56296	92.64397	74.09998
5	-287.30054	43.22844	92.21156	74.19997
6	-286.71509	42.89503	91.87708	74.29996
7	-286.18848	141.75359	91.54105	74.39995
REB. 8	-284.36206	51.35136	90.40222	74.49994

STAGE	X(1)	Y(1)
1	0.9505086	0.9799908
2	0.9172240	0.9658566
3	0.8816091	0.9500788
4	0.8453496	0.9332709
5	0.8105480	0.9163832
6	0.7787664	0.9002675
7	0.7511820	0.8857015
REB. 8	0.6568806	0.8313727

-----PASS NUMBER 2 IS COMPLETE-----

PASS	REFLUX RATIO	BOTTOMS COMP.
------	--------------	---------------

3	0.83239	0.7413213
---	---------	-----------

4	1.01736	0.5858468
---	---------	-----------

5	0.95675	0.6324053
---	---------	-----------

6	0.98648	0.6099548
---	---------	-----------

FINAL CONVERGENCE ACHIEVED ON BOTTOMS

COMPOSITION ---TOWER NUMBER 1

THE FEED IS INTRODUCED BETWEEN STAGES 6 AND 7

RLOW= 0.83239 R= 0.98648 RHIGH= 1.01736

STAGE	TEMPERATURE DEGREES F	PRESSURE PSIA	LIQUID RATE MOLES/HR.	VAPOR RATE MOLES/HR.	X(COMP.1)	Y(COMP.1)
COND.	-290.21606	73.50000	48.64864	0.00000	0.97999	0.99205
1	-289.67944	73.80000	47.62366	96.63976	0.95051	0.97999
2	-289.12134	73.89999	47.16379	96.27255	0.91619	0.96541
3	-288.48999	73.99998	46.78523	95.81218	0.87831	0.94858
4	-287.81030	74.09998	46.31546	95.43393	0.83878	0.93014
5	-287.11963	74.19997	45.83182	94.96405	0.80002	0.91112
6	-286.45801	74.29996	45.46831	94.48053	0.76429	0.89269
7	-285.85571	74.39995	143.71130	94.11440	0.73298	0.87576
REB. 8	-283.40210	74.49994	51.35136	92.36002	0.60995	0.80135

ENTHALPY BALANCE (BTU/HR.)

FEED ENTHALPY= 0.22166063E 06 REBOILER DUTY= 0.20419519E 06

TOTAL ENTHALPY IN = 0.42585581E 06

DISTILLATE ENTHALPY = 0.10530550E 06 BOTTOMS ENTHALPY = 0.11661031E 06 CONDENSER DUTY = -0.20394000E 06

TOTAL ENTHALPY OUT = 0.42585581E 06

TOWER NUMBER 1 IS COMPLETE

_COLUMN_NUMBER_ 2-----PROBLEM NUMBER

INPUT DATA USED IN CALCULATIONS

FEED RATE XF(1) XB(1) DIST.RATE DIST.SPLIT ZD(1)
MOLS/HOUR
51.35136 .609954 .010000 31.43719 0.00000 .990000

PRESSURE DROP/STAGE=0.1000 CONDENSER PRESSURE DROP=0.3000 REBOILER PRESSURE DROP=0.1000

FLASHED FEED

THE FRACTION FEED VAPORIZED= 0.2265

XFEED= 0.54696 YFEED= 0.82501 HFEED= 0.11659275E 06 TFEED=-310.02368

AIR PLANT---SECOND COLUMN---ABSORBER SECTION

STAGE	TEMPERATURE DEGREES F	PRESSURE PSIA	LIQUID RATE MOLES/HR.	VAPOR RATE MOLES/HR.	X(COMP.1)	Y(COMP.1)
REB.	-290.58301	20.09999	20.45718	52.29448	0.01000	0.01000
2	-291.19800	20.00000	72.75166	51.68848	0.01000	0.03935
3	-292.63672	19.89999	72.14566	50.66336	0.03103	0.11465
4	-295.69458	19.79999	71.12056	49.54538	0.08455	0.27084
5	-300.51636	19.69998	70.00256	49.69934	0.19462	0.49053
6	-305.44775	19.59998	70.15652	50.60252	0.35041	0.68028
7	-308.74414	19.49997	71.05971	51.45917	0.48731	0.78825
8	-310.84668	19.39996	32.19836	63.77678	0.59142	0.84946
9	-312.76953	19.29996	32.88261	64.67992	0.70124	0.90108
10	-314.36426	19.19995	33.78568	65.23689	0.80401	0.94069
11	-315.46875	19.09995	34.34291	65.70618	0.88084	0.96611
12	-316.15894	18.99994	34.81168	65.95792	0.92963	0.98072
13	-316.57300	18.89993	35.06361	66.23381	0.95736	0.98856
TOP 14	-316.82959	18.79993	35.33998	66.29770	0.97225	0.99263

REVISED VALUES BASED ON TRUE PRESSURE PROFILE

TRIAL NUMBER 2
THE FEED IS INTRODUCED BETWEEN STAGES 7 AND 8

INPUT DATA USED IN CALCULATIONS

FEED RATE MOLS/HOUR	XF(1)	XB(1)	DIST.RATE MOLS/HOUR	DIST.SPLIT	ZD(1)
51.35135	.609954	.010000	31.43716	0.00000	.990000

FLASHED FEED

THE FRACTION FEED VAPORIZED= 0.2257

XFEED= 0.54723 YFEED= 0.82519 HFEED= 0.11659819E 06 TFEED=-309.94116

AIR PLANT---SECOND COLUMN---ABSORBER SECTION

STAGE	TEMPERATURE DEGREES F	PRESSURE PSIA	LIQUID RATE MOLES/HR.	VAPOR RATE MOLES/HR.	X(COMP.1)	Y(COMP.1)
REB.	-290.58301	20.09999	20.45720	52.29445	0.01000	0.01000
2	-291.19800	20.00000	72.75165	51.68845	0.01000	0.03935
3	-292.63672	19.89999	72.14565	50.66342	0.03103	0.11465
4	-295.69458	19.79999	71.12062	49.54532	0.08455	0.27084
5	-300.51636	19.69998	70.00250	49.69937	0.19462	0.49053
6	-305.44775	19.59998	70.15657	50.60242	0.35041	0.68028
7	-308.74414	19.49997	71.05963	51.50163	0.48731	0.78825
8	-310.84668	19.39996	32.19554	63.77888	0.59142	0.84945
9	-312.76953	19.29996	32.88477	64.68240	0.70123	0.90107
10	-314.36401	19.19995	33.78828	65.23833	0.80400	0.94069
11	-315.46875	19.09995	34.34425	65.70795	0.88083	0.96611
12	-316.15894	18.99994	34.81401	65.95979	0.92963	0.98071
13	-316.57300	18.89993	35.06610	66.23701	0.95736	0.98856
TOP 14	-316.82959	18.79993	35.34268	66.30185	0.97224	0.99263

PRESSURE VARIATIONS HAVE BEEN DAMPED

TRIAL	OVERHEAD FEED REQUIRED	OVERHEAD FEED ACTUAL	CONDENSER DUTY(1)	REBOILER DUTY(2)
2	35.0025780	35.4087520	0.2039400E 06	0.2039400E 06

THE SECOND TOWER IS INDEPENDENTLY CLOSED

THE FEED IS INTRODUCED BETWEEN STAGES 7 AND 8

STAGE	TEMPERATURE DEGREES F	PRESSURE PSIA	LIQUID RATE MOLES/HR.	VAPOR RATE MOLES/HR.	X(COMP.1)	Y(COMP.1)
REB.	-290.58301	20.09999	20.45720	52.29445	0.01000	0.01000
2	-291.19800	20.00000	72.75165	51.68845	0.01000	0.03935
3	-292.63672	19.89999	72.14565	50.66342	0.03103	0.11465
4	-295.69458	19.79999	71.12062	49.54532	0.08455	0.27084
5	-300.51636	19.69998	70.00250	49.69937	0.19462	0.49053
6	-305.44775	19.59998	70.15657	50.60242	0.35041	0.68028
7	-308.74414	19.49997	71.05963	51.50163	0.48731	0.78825
8	-310.84668	19.39996	32.19554	63.77888	0.59142	0.84945
9	-312.76953	19.29996	32.88477	64.68240	0.70123	0.90107
10	-314.36401	19.19995	33.78828	65.23833	0.80400	0.94069
11	-315.46875	19.09995	34.34425	65.70795	0.88083	0.96611
12	-316.15894	18.99994	34.81401	65.95979	0.92963	0.98071
13	-316.57300	18.89993	35.06610	66.23701	0.95736	0.98856
TOP 14	-316.82959	18.79993	35.34268	66.30185	0.97224	0.99263

-----ENTHALPY BALANCE (BIU/HR.)-----

FEED ENTHALPY= 0.11661031E 06 REBILIER DUTY= 0.20394000E 06 REFLUX ENTHALPY= 0.50928340E 05

TOTAL ENTHALPY IN = 0.37147863E 06

BOTTOMS ENTHALPY 0.10508919E 06 TOP PRODUCT ENTHALPY 0.26658419E 06

TOTAL ENTHALPY OUT = 0.37167338E 06

-----TOWER NUMBER TWO IS COMPLETE-----

FINAL CONVERGENCE HAS BEEN ACHIEVED FOR BOTH TOWERS

**FORTRAN ** STOP

Q3RT 00:16:56

- (d) Pressure drops--stage=0.1 psi.,
condenser=0.3 psi., reboiler=0.1 psi.
Same values as in example number 1.
- (e) Equilibrium reference pressure=14.7 psia.
- (f) Tolerances = 10^{-6} and 10^{-4}
Same values as in example number 1.
- (g) Initial temperature and pressure estimates.

	<u>TOP</u>	<u>BOTTOM</u>
T, °F.	190.0	220.0
P, psia.	14.7	16.9
- (h) Product purities, light key:
overhead =0.98 : bottoms = 0.10

(3) Basic data

- (a) Enthalpy data
Enthalpy data ⁵ at 176°F. and 230.72°F.
were supplied to the model in the same
order as in example number 1.
- (b) Equilibrium data
Vapor-liquid equilibrium data calculated
from vapor pressure data ⁶ were entered at
176°F. and 230.72°F in the same order as
in example number 1.

5. Maxwell, J.B., Data Book on Hydrocarbons, First Edition, Princeton, N.J., D. Van Nostrand Company, 1958.

6. Perry, J.H., Chemical Engineers' Handbook, Fourth Edition New York: Mc Graw-Hill Book Co., 1963, Table 13-1.

The results of the calculation are that the number of stages equals 12 plus a condenser and a reboiler. The feed enters between stages 8 and 9, and the condenser and reboiler duties are approximately 1,880,000 Btu/hour each. The reflux ratio is 2.07455 (see attached printout). As before, DISTL was used to check the solution with favorable results.

_COLUMN_NUMBER_--1-----PROBLEM NUMBER 2

-----TOTAL CONDENSER==ALL LIQUID DISTILLATE-----

INPUT DATA USED IN CALCULATIONS

FEEED RATE XF(1) XB(1) DIST.RATE DIST.SPLIT ZD(1)
MOLS/HOUR
100.00000 .500000 .100000 45.45451 0.00000 .980000

PRESSURE DROP/STAGE=0.1000 CONDENSER PRESSURE DROP=0.3000 REBOILER PRESSURE DROP=0.1000

-----*****CONSTANTIS*****-----IQWEB_NUMBER_1-----

	EQUILIBRIUM	PRESSURE	ENTHALPY-LIQUID	ENTHALPY-VAPOR
A1	13.20149	14.70000	-14482.75300	7871.65620
B1	-6686.67960	14.70000	39.96346	25.69080
A2	13.49274	14.70000	-17539.39400	7759.37500
B2	-7463.15620	14.70000	47.12720	31.83479

BUBBLE POINT FEED

THE FRACTION FEED VAPORIZED=-0,0000

XFEED= 0,50000

YFEED= 0,70703

HFEED= 0,12832080E 07

TFEED= 202,37442

MINIMUM REFLUX = 1,31846

REFLUX RATIO= 1,97769

THE FRACTION DISTILLATE VAPORIZED= 0,0001

TEMPERATURES---DEGREES FAHRENHEIT

TOP	BOTTOM	FEED	CONDENSER
190,00000	220,00000	202,37442	175,49054

PRESSURES---PSIA

PTOP= 14,70000	PBOTTOM= 16,89999
----------------	-------------------

FIRST PASS---DETERMINATION OF NUMBER OF STAGES

RECTIFYING SECTION

STAGE	TEMPERATURE DEGREES F	LIQUID RATE MOLES/HR.	VAPOR RATE MOLES/HR.	PRESSURE PSIA
COND.	175.49054	45.45451	0.00000	14.40000
1	177.82257	89.55740	135.34966	14.70000
2	179.92676	88.63678	135.01279	14.80000
3	182.79744	87.52528	134.09134	14.90000
4	186.45186	86.22510	132.98007	15.00000
5	190.64641	85.15283	131.67961	15.10000
6	194.91656	84.03835	130.60725	15.20000
7	198.75598	83.38620	129.49283	15.30000

THE NET VAPOR ENTERING THE RECTIFYING SECTION IS 128.84074

STAGE	X(1)	Y(1)
1	0.9509960	0.9799982
2	0.9068618	0.9607602
3	0.8449672	0.9316537
4	0.7671662	0.8911228
5	0.6815289	0.8406337
6	0.5994257	0.7854034
7	0.5305905	0.7330140

THE NUMBER OF STAGES IN THE RECTIFYING SECTION ARE 7

STRIPPING SECTION

STAGE	TEMPERATURE DEGREES F	LIQUID RATE MOLES/HR.	VAPOR RATE MOLES/HR.	PRESSURE PSIA
8	205.98503	183.67444	129.63266	16.49995
9	209.11475	182.78584	129.12891	16.59996
10	213.47939	181.71730	128.24037	16.69997
11	218.99167	180.93781	127.17192	16.79997
12	225.09351	179.84297	126.39232	16.89998
REB. 13	232.23511	54.54549	125.29747	16.99998

THE NET LIQUID ENTERING THE STRIPPING SECTION IS 184.17822

STAGE	X(1)	Y(1)
8	0.4840097	0.6922545
9	0.4337068	0.6462196
10	0.3642951	0.5756449
11	0.2805433	0.4776542
12	0.1940030	0.3584580
REB. 13	0.1000000	0.2349251

THE NUMBER OF STAGES IN THE STRIPPING SECTION ARE 6

THE TOTAL NUMBER OF STAGES IN TOWER ARE 13

PASS NUMBER 1 IS COMPLETE

REVISED VALUES BASED ON TRUE PRESSURE PROFILE

BUBBLE POINT FEED

THE FRACTION FEED VAPORIZED=0.0000

XFEED= 0.50000 YFEED= 0.70786 HFEED= 0.12734510E 07 TFEED= 200.13374

MINIMUM REFLUX = 1.30928 REFLUX RATIO= 1.96392

THE FRACTION DISTILLATE VAPORIZED= 0.0001

TEMPERATURES---DEGREES FAHRENHEIT

TOP	BOTTOM	FEED	CONDENSER
177.82257	225.09351	200.13374	175.49057

PRESSURES---PSIA

PTOP= 14.70000 PBOTTOM= 15.80000

PASS NUMBER 2

THE VALUE OF THE REFLUX RATIO= 1.96392

STAGE	TEMPERATURE DEGREES F	LIQUID RATE MOLES/HR.	VAPOR RATE MOLES/HR.	PRESSURE PSIA
COND.	175.49057	134.72343	0.00000	14.40000
1	177.82260	89.00259	134.72343	14.70000
2	179.92345	88.10017	134.45793	14.80000
3	182.78441	87.00748	133.55486	14.90000
4	186.42134	85.69516	132.46196	15.00000
5	190.59105	84.61742	131.14963	15.10000
6	194.83398	83.51653	130.07191	15.20000
7	198.65125	82.86130	128.97098	15.30000
8	201.76521	82.42809	128.31586	15.40000
9	204.13220	181.83028	127.88359	15.50000
10	208.28995	180.56090	127.28484	15.59999
11	213.65233	179.56866	126.01543	15.69999
12	219.74643	179.25330	125.02295	15.79999
REB. 13	225.72311	54.54549	124.70741	15.89999

STAGE	X(1)	Y(1)
1	0.9509960	0.9799982
2	0.9069512	0.9608005
3	0.8452916	0.9318123
4	0.7678801	0.8915163
5	0.6827453	0.8413970
6	0.6011286	0.7866223
7	0.5326386	0.7346573
8	0.4808152	0.6911110
9	0.4446200	0.6582447
10	0.3782091	0.5922993
11	0.2959069	0.4986304
12	0.2083721	0.3813768
REB. 13	0.1290751	0.2557716

PASS	REFLUX RATIO	BOTTOMS COMP.
3	1.76753	0.2336791
4	2.16031	0.0828395
5	2.03977	0.1079320
6	2.08895	0.0959463
7	2.06834	0.1012725
8	2.07596	0.0989923
9	2.07237	0.1004747
10	2.07384	0.1002142
11	2.07455	0.1000913

FINAL CONVERGENCE ACHIEVED ON BOTTOMS

COMPOSITION ---TOWER NUMBER 1

THE FEED IS INTRODUCED BETWEEN STAGES 8 AND 9

RLOW= 1.76753 R= 2.07455 RHIGH= 2.16031

STAGE	TEMPERATURE DEGREES F	PRESSURE PSIA	LIQUID RATE MOLES/HR.	VAPOR RATE MOLES/HR.	X(COMP.1)	Y(COMP.1)
COND.	175.49057	14.40000	45.45451	0.00000	0.98000	0.99202
1	177.82260	14.70000	93.95271	139.75229	0.95100	0.98000
2	179.95355	14.80000	93.04195	139.40825	0.90618	0.96045
3	182.90051	14.90000	91.75182	138.49698	0.84243	0.93041
4	186.69380	15.00000	90.48480	137.20638	0.76153	0.88800
5	191.08351	15.10000	89.08070	135.93921	0.67197	0.83458
6	195.54637	15.20000	87.91554	134.53520	0.58650	0.77604
7	199.54027	15.30000	87.09859	133.37007	0.51535	0.72061
8	202.75594	15.40000	86.58336	132.55310	0.46235	0.67469
9	205.16382	15.50000	185.84456	132.03882	0.42597	0.64055
10	209.97350	15.59999	184.81569	131.29907	0.34957	0.56138
11	215.87860	15.69999	183.94048	130.26993	0.26079	0.45406
12	222.15012	15.79999	183.45955	129.39510	0.17340	0.32857
REB.-13	227.86775	15.89999	54.54542	128.21383	0.10009	0.20446

ENTHALPY BALANCE (BTU/HR.)

FEED ENTHALPY= 0.12734510E 07 REBILDER DUTY= 0.18966280E 07

TOTAL ENTHALPY IN = 0.31700790E 07

DISTILLATE ENTHALPY = 0.49743413E 06 BOTTOMS ENTHALPY = 0.80130600E 06 CONDENSER DUTY =-0.18713390E 07

TOTAL ENTHALPY OUT = 0.31700790E 07

TOWER NUMBER 1 IS COMPLETE

C. Example No. 3 - Dual Distillation Column Complex

The purpose of this example is to illustrate the additional feature of the model to solve multiple column arrangements. Benzene and toluene are again separated, but the first column light component purities are set at 0.80 distillate and 0.20 bottoms. The second column, which uses the distillate of the first column as its feed stream, duplicates the separation obtained in example number 2, i.e. 0.98 distillate and 0.10 bottoms (light key composition). The data for the first column of the complex is the same as in example number 2 except that the operating pressure of the column is 5 psi. higher, and a dew point distillate is specified. The higher operating pressure is necessary for this column so that a pressure inversion at the feed inlet to the second tower is avoided. The input data to the second column follows the data for the first column but deletes the type and feed thermal codes since the former need be set only once, and the latter is calculated by the program. The distillate code for the second tower was set for a dew point distillate, and all the subsequent data matches the data supplied for example number 2. The results of the calculation appear on the next page.

	<u>TOWER 1</u>	<u>TOWER 2</u>
Stages*	5	10
Reflux Ratio	0.77999	1.07018
Condenser Duty (Btu/hr.)	547,018	575,062
Reboiler Duty (Btu/hr.)	1,224,696	1,120,673

* Excluding the condenser and reboiler

Please see the attached printout for further information.

Both columns were checked using DISTL, with favorable results.

_COLUMN_NUMBER_ 1-----PROBLEM NUMBER 3

-----PARTIAL CONDENSED==ALL VAPOR DISTILLATE-----

INPUT DATA USED IN CALCULATIONS

FEED RATE XF(1) XB(1) DIST.RATE DIST.SPLIT ZD(1)
MOLS/HOUR
100.00000 .500000 .200000 49.99998 1.00000 .800000

PRESSURE DROP/STAGE=0.1000 CONDENSER PRESSURE DROP=0.3000 REBOILER PRESSURE DROP=0.1000

-----*****CONSTANTS*****-----TOWER_NUMBER_1-----

	EQUILIBRIUM	PRESSURE	ENTHALPY-LIQUID	ENTHALPY-VAPOR
A1	13.20149	14.70000	-14482.75300	7871.65620
B1	-6686.67960	14.70000	39.96346	25.69080
A2	13.49274	14.70000	-17539.39400	7759.37500
B2	-7463.15620	14.70000	47.12720	31.83479

BUBBLE POINT FEED

THE FRACTION FEED VAPORIZED= 0.0000

XFEED= 0.50000 YFEED= 0.70170 HFEED= 0.13476670E 07 TFEED= 217.17380

MINIMUM REFLUX = 0.48737 REFLUX RATIO= 0.73106

THE FRACTION DISTILLATE VAPORIZED= 1.0000

TEMPERATURES---DEGREES FAHRENHEIT

TOP	BOTTOM	FEED	CONDENSER
190.00000	220.00000	217.17380	209.21852

PRESSURES---PSIA

PTOP= 19.70000	PBOTTOM= 20.00000
----------------	-------------------

FIRST PASS---DETERMINATION OF NUMBER OF STAGES

RECTIFYING SECTION

STAGE	TEMPERATURE DEGREES F	LIQUID RATE MOLES/HR.	VAPOR RATE MOLES/HR.	PRESSURE PSIA
COND.	209.21852	0.00000	49.99998	19.39999
1	215.09871	36.02991	86.55287	19.70000

THE NET VAPOR ENTERING THE RECTIFYING SECTION IS 86.02997

STAGE	X(1)	Y(1)
1	0.5297618	0.7267326

THE NUMBER OF STAGES IN THE RECTIFYING SECTION ARE 1

STRIPPING SECTION

STAGE	TEMPERATURE DEGREES F	LIQUID RATE MOLES/HR.	VAPOR RATE MOLES/HR.	PRESSURE PSIA
2	217.21938	135.63994	85.94817	19.69997
3	219.62123	135.22533	85.63994	19.79997
4	223.38692	134.55545	85.22531	19.89998
5	228.85904	133.73505	84.55545	19.99998
REB. 6	236.19579	50.00002	83.73503	20.09999

THE NET LIQUID ENTERING THE STRIPPING SECTION IS 135.94818

STAGE	X(1)	Y(1)
2	0.4897830	0.6930556
3	0.4520080	0.6589699
4	0.3917152	0.5998561
5	0.3066942	0.5050818
REB. 6	0.2000000	0.3704036

THE NUMBER OF STAGES IN THE STRIPPING SECTION ARE 5

THE TOTAL NUMBER OF STAGES IN TOWER ARE 6

PASS NUMBER 1 IS COMPLETE

REVISED VALUES BASED ON TRUE PRESSURE PROFILE

BUBBLE POINT FEED

THE FRACTION FEED VAPORIZED==0.0000

XFEED= 0.50000 YFEED= 0.70146 HFEED= 0.13505580E 07 TFEED= 217.83864

MINIMUM REFLUX = 0.48911 REFLUX RATIO= 0.73366

THE FRACTION DISTILLATE VAPORIZED= 1.0000

TEMPERATURES---DEGREES FAHRENHEIT

TOP	BOTTOM	FEED	CONDENSER
215.09871	228.85904	217.83864	209.21852

PRESSURES---PSIA

PTOP= 19.70000 PBDTOM= 20.09999

PASS NUMBER 2

THE VALUE OF THE REFLUX RATIO= 0.73366

STAGE	TEMPERATURE DEGREES F	LIQUID RATE MOLES/HR.	VAPOR RATE MOLES/HR.	PRESSURE PSIA
COND.	209.21852	86.68300	49.99998	19.39999
1	215.10840	36.30380	86.68300	19.70000
2	217.96738	36.16454	86.30386	19.79999
3	219.49060	135.49129	86.16489	19.89998
4	222.98116	134.59044	85.49135	19.99997
5	228.12146	133.80042	84.59035	20.09996
REB. 6	234.87349	50.00002	83.80057	20.19995

STAGE	X(1)	Y(1)
1	0.5295762	0.7265821
2	0.4821521	0.6862466
3	0.4604177	0.6665953
4	0.4044735	0.6127251
5	0.3239396	0.5253351
REB. 6	0.2243565	0.3978894

-----PASS NUMBER 2 IS COMPLETE-----

PASS REFLUX RATIO BOTTOMS COMP.

3	0.66030	0.2834946
4	0.80703	0.1840401
5	0.75857	0.2088265
6	0.77931	0.1975552
7	0.77188	0.2018718
8	0.77535	0.2003850
9	0.77661	0.1999303

FINAL CONVERGENCE ACHIEVED ON BOTTOMS

COMPOSITION ---TOWER NUMBER 1

THE FEED IS INTRODUCED BETWEEN STAGES 2 AND 3

RLDW= 0.66030 R= 0.77661 RHIGH= 0.80703

STAGE	TEMPERATURE DEGREES F	PRESSURE PSIA	LIQUID RATE MOLES/HR.	VAPOR RATE MOLES/HR.	X(COMP.1)	Y(COMP.1)
COND.	209.21852	19.39999	0.00000	49.99998	0.62651	0.80000
1	215.26318	19.70000	38.41827	88.83038	0.52662	0.72416
2	218.27600	19.79999	38.10402	88.41820	0.47647	0.68121
3	219.88206	19.89998	137.37163	88.10423	0.45334	0.66008
4	223.80052	19.99997	136.54755	87.37155	0.39036	0.59832
5	229.43332	20.09996	135.82042	86.54761	0.30287	0.50033
REB. 6	236.53537	20.19295	50.00002	85.82036	0.19993	0.36281

ENTHALPY BALANCE (BTU/HR.)

FEED ENTHALPY= 0.13505580E 07 REBOILER DUTY= 0.12322970E 07

TOTAL ENTHALPY IN = 0.25828550E 07

DISTILLATE ENTHALPY = 0.12932130E 07 BOTTOMS ENTHALPY = 0.74499275E 06 CONDENSER DUTY = -0.54465000E 06

TOTAL ENTHALPY OUT = 0.25828550E 07

TOWER NUMBER 1 IS COMPLETE

_COLUMN_NUMBER_ 2-----PROBLEM NUMBER 3

DOUBLE COLUMN--DISTILLATE(1)=FEED(2)

-----PABIAL CONDENSER==ALL VAPOR DISTILLATE.-----

-----*****CONSTIANIS***** TOWER NUMBER 2-----

	EQUILIBRIUM	PRESSURE	ENTHALPY-LIQUID	ENTHALPY-VAPOR
A1	13.20149	14.70000	-14482.75300	7871.65620
B1	-6686.67960	14.70000	39.96346	25.69080
A2	13.49274	14.70000	-17539.39400	7759.37500
B2	-7463.15620	14.70000	47.12720	31.83479

INPUT DATA USED IN CALCULATIONS

FEED RATE MOLS/HOUR	XF(1)	XB(1)	DIST.RATE MOLS/HOUR	DIST.SPLIT	ZD(1)
50,00000	.800000	.100000	39,77271	1,00000	.980000

PRESSURE DROP/STAGE=0,1000 CONDENSER PRESSURE DROP=0,3000 REBOILER PRESSURE DROP=0,1000

SUBCOOLED FEED

THE FRACTION FEED VAPORIZED= 0,0000

XFEED= 0,80000 YFEED= 0,90828 HFEED= 0,57080150E 06 TFEED= 180,39543

MINIMUM REFLUX = 0,66237 REFLUX RATIO= 0,99356

THE FRACTION DISTILLATE VAPORIZED= 1,0000

TEMPERATURES---DEGREES FAHRENHEIT

TOP	BOTTOM	FEED	CONDENSER
190,00000	220,00000	180,39543	176,57759

PRESSURES---PSIA

PTOP= 14,70000 PBOTTOM= 16,89999

FIRST PASS---DETERMINATION OF NUMBER OF STAGES

RECTIFYING SECTION

STAGE	TEMPERATURE DEGREES F	LIQUID RATE MOLES/HR.	VAPOR RATE MOLES/HR.	PRESSURE PSIA
COND.	176.57759	0.00000	39.77271	14.40000
1	179.10501	39.36841	79.28918	14.70000
2	180.94701	39.08357	79.14143	14.80000
3	182.86255	38.65633	78.85622	14.90000
4	184.75107	38.34421	78.42892	15.00000

THE NET VAPOR ENTERING THE RECTIFYING SECTION IS 78.11685

STAGE	X(1)	Y(1)
1	0.9174139	0.9654914
2	0.8808656	0.9488668
3	0.8433629	0.9308660
4	0.8074348	0.9126540

THE NUMBER OF STAGES IN THE RECTIFYING SECTION ARE 4

STRIPPING SECTION

STAGE	TEMPERATURE DEGREES F	LIQUID RATE MOLES/HR.	VAPOR RATE MOLES/HR.	PRESSURE PSIA
5	191.35066	89.39986	79.59860	16.39995
6	193.88474	88.63200	79.17258	16.49995
7	198.27934	87.52306	78.40471	16.59996
8	205.18433	86.09061	77.29576	16.69997
9	214.18745	84.96010	75.86333	16.79997
10	223.42778	84.14328	74.73280	16.89998
REB. 11	232.23511	10.22729	73.91599	16.99998

THE NET LIQUID ENTERING THE STRIPPING SECTION IS 89.82590

STAGE	X(1)	Y(1)
5	0.7824071	0.8984956
6	0.7329554	0.8705586
7	0.6451916	0.8155196
8	0.5137916	0.7173279
9	0.3588517	0.5695757
10	0.2185255	0.3942760
REB. 11	0.1000000	0.2349251

THE NUMBER OF STAGES IN THE STRIPPING SECTION ARE 7

THE TOTAL NUMBER OF STAGES IN TOWER ARE 11

PASS NUMBER 1 IS COMPLETE

REVISED VALUES BASED ON TRUE PRESSURE PROFILE

SUBCOOLED FEED

THE FRACTION FEED VAPORIZED= 0.0000

XFEED= 0.80000 YFEED= 0.90778 HFEED= 0.57080156E 06 TFEED= 180.39543

MINIMUM REFLUX = 0.67013 REFLUX RATIO= 1.00519

THE FRACTION DISTILLATE VAPORIZED= 1.0000

TEMPERATURES---DEGREES FAHRENHEIT

TOP	BOTTOM	FEED	CONDENSER
179.10501	223.42778	180.39543	176.57747

PRESSURES---PSIA

PTOP= 14.70000 PBOTTOM= 15.60000

PASS NUMBER 2

THE VALUE OF THE REFLUX RATIO= 1.00519

STAGE	TEMPERATURE DEGREES F	LIQUID RATE MOLES/HR.	VAPOR RATE MOLES/HR.	PRESSURE PSIA
COND.	176.57747	79.75182	39.77271	14.40000
1	179.11238	39.78780	79.75182	14.70000
2	180.96912	39.46754	79.56053	14.80000
3	182.90559	39.06155	79.24034	14.90000
4	184.82182	38.75809	78.83434	15.00000
5	186.63271	38.52681	78.53072	15.10000
6	188.27635	88.59364	78.29874	15.20000
7	192.36449	87.47702	78.36627	15.30000
8	198.94359	86.14452	77.24968	15.40000
9	207.82092	84.77040	75.91710	15.50000
10	217.24182	84.10313	74.54292	15.59999
REB. 11	225.07204	10.22729	73.87541	15.69999

STAGE	X(1)	Y(1)
1	0.9172238	0.9654067
2	0.8803047	0.9486059
3	0.8423044	0.9303444
4	0.8057379	0.9117733
5	0.7725309	0.8939947
6	0.7439999	0.8779156
7	0.6619615	0.8279324
8	0.5349498	0.7363611
9	0.3792302	0.5935447
10	0.2335880	0.4175403
REB. 11	0.1267819	0.2520816

-----PASS NUMBER 2 IS COMPLETE-----

PASS	REFLUX RATIO	BOTTOMS COMP.
3	0.90467	0.2018217
4	1.10571	0.0892121
5	1.04582	0.1088366
6	1.07427	0.0988522
7	1.06552	0.1014912
8	1.07018	0.0999271

FINAL CONVERGENCE ACHIEVED ON BOTTOMS

COMPOSITION ---TOWER NUMBER 2

THE FEED IS INTRODUCED BETWEEN STAGES 5 AND 6

RLDW= 0.90467 R= 1.07018 RHIGH= 1.10571

STAGE	TEMPERATURE DEGREES F	PRESSURE PSIA	LIQUID RATE MOLES/HR.	VAPOR RATE MOLES/HR.	X(COMP.1)	Y(COMP.1)
COND.	176.57747	14.40000	0.00000	39.77271	0.95089	0.98000
1	179.15225	14.70000	42.37041	82.33676	0.91619	0.96495
2	181.09787	14.80000	42.04416	82.14288	0.87706	0.94709
3	183.17255	14.90000	41.64676	81.81699	0.83575	0.92710
4	185.26540	15.00000	41.22600	81.41951	0.79514	0.90622
5	187.26007	15.10000	40.96257	80.99861	0.75791	0.88591
6	189.07933	15.20000	90.83267	80.73448	0.72560	0.86732
7	193.97829	15.30000	89.72934	80.60529	0.62753	0.80498
8	201.50391	15.40000	88.24966	79.50211	0.48573	0.69539
9	210.90388	15.50000	87.02844	78.02222	0.32724	0.53629
10	220.03810	15.59999	86.52809	76.80130	0.19204	0.35750
REB. 11	227.06107	15.69999	10.22722	76.30081	0.09993	0.20438

ENTHALPY BALANCE (BTU/HR.)

FEED ENTHALPY= 0.57080156E 06 REBOILER DUTY= 0.11206730E 07

TOTAL ENTHALPY IN = 0.16914740E 07

DISTILLATE ENTHALPY = 0.96654863E 06 BOTTOMS ENTHALPY = 0.14986531E 06 CONDENSER DUTY =-0.57506200E 06

TOTAL ENTHALPY OUT = 0.16914750E 07

TOWER NUMBER 2 IS COMPLETE

APPENDIX A

INPUT DATA SHEET

<u>Card No.</u>	<u>Input</u>	<u>Column No.</u>
1.	Tower Configuration code(integer) 1- Single column 2- Two columns-bottoms(1)= feed(2) 3- Two columns-distillate(1)= feed(2) 4- Linde "Double Column".	2
2.	Feed thermal code(integer) 0- Superheated feed 1- Dew point feed 2- Flashed feed 3- Bubble point feed 4- Subcooled feed	2
3.	Distillate thermal code (integer) 1- All vapor distillate 2- Liquid-vapor distillate 3- All liquid distillate 4- Subcooled distillate	2
4.	Fraction vapor distillate (optional) Value between (0-1)--input only when distillate code=2.	1-12

<u>Card No.</u>	<u>Input</u>	<u>Column No.</u>
5.	A. Feed rate, lb-moles/hr.	1-12
	B. Feed composition, mole frac.	13-24
6.	Reflux factor Rfactor= Ractual/Rmin	1-12
7.	Pressure drops, psi.	
	A. Stage pressure drop	1-12
	B. Condenser pressure drop	13-24
	C. Reboiler pressure drop	25-36
8.	Equilibrium reference pressure	1-12
9.	Tolerances	
	A. Bubble-dew point component summations	1-12
	B. Overall bottoms composition	13-24
	10.	Initial temperature and pressure estimates
	A. Temperature (top), °F.	1-12
	B. Pressure (top), psia	13-24
	C. Temperature (bottom), °F.	25-36
	D. Pressure (bottom), psia	37-48

<u>Card No.</u>	<u>Input</u>	<u>Column No.</u>
11.	Product purities, light component	
	A. Distillate composition	1-12
	B. Bottoms composition	13-24
12.	Enthalpy data (temperature 1), Btu/lb-mole	
	A. Temperature (1), °F.	1-12
	B. Liquid enthalpy-comp.(1)	13-24
	C. Liquid enthalpy-comp.(2)	25-36
	D. Vapor enthalpy-comp.(1)	37-48
	E. Vapor enthalpy-comp.(2)	49-56
13.	Enthalpy data (temperature 2), Btu/lb-mole	
	A. Temperature (2), °F.	1-12
	B. Liquid enthalpy-comp.(1)	13-24
	C. Liquid enthalpy-comp.(2)	25-36
	D. Vapor enthalpy-comp.(1)	37-48
	E. Vapor enthalpy-comp.(2)	49-56

<u>Card No.</u>	<u>Input</u>	<u>Column No.</u>
14.	Vapor-liquid equilibrium data (temperature 1)	
	A. Temperature (1), °F.	1-12
	B. Equilibrium constant-comp.1	13-24
	C. Equilibrium constant-comp.2	25-36
15.	Vapor-liquid equilibrium data (temperature 2)	
	A. Temperature (2), °F.	1-12
	B. Equilibrium constant-comp.1	13-24
	C. Equilibrium constant-comp.2	25-36
16.	Feed temperature, °F. (optional) Required with a flashed, subcooled or superheated feed.	1-12
17.	Distillate drum temperature, °F. (optional) Required with a subcooled distillate.	1-12

* This completes the data for tower configuration code (1). For a code of (2) or (3), the data for the second tower follows card number 17, beginning with the distillate thermal code card, and the feed rate, feed composition card is deleted. All other cards follow in the order outlined above. For a Linde "Double Column", the absorber data begins with the pressure drop card (card 7), deleting cards 1 to 6.

```

// JOB CC305/DC18,SOREL,3000,50000,J.A.BAZAN
// PARAM LTST=YES,DEBUG=YES,MAP=NO
// FORTRN
PROGRAM SOREL
COMMON F,VAP
COMMON A(2),P(2),PCDN(2),FRATE,RFACTR,DIST
COMMON DELTA2,TTOP,TRUT
COMMON APL(2),BHL(2),AMV(2),BMV(2)
COMMON /TDLTDL/TDL,TDLB,TDLGA
COMMON/VARPLS/ X(100),Y(100),T(100),PATEL(100),RATEV(100)
COMMON/VARPLS/ P(100)
COMMON/CONREP/ DL,DV,XD,YD,QC,QK,DISTH,BOTTH,XP1,XF1,TFEED
COMMON/CONREP/ TOLND,XFEED,YFEED,HFEED,VV,BUT
COMMON/PRSSR/ CUMDPD,REBPD,CORRECT
DIMENSION HL(2,2),EK(2,2),TEMP(2),TEO(2),HV(2,2)
DIMENSION S(2,30)
C
C-----
C INPUT SECTION
C READ 529,NPROB
C NPROB IS THE NUMBER OF PROBLEMS TO BE SOLVED.
C TPROB=1
1605 TPRESS=1
C IND=0
C INDEY=0
C ITOWER=1
C TTRY=0
C TDBL=0
C TCONV=0
C READ 529,ITCODE
C READ 529,IFCODE
3175 READ 529,ITCODE
C IF(ITOWER.EQ.2) GO TO 900
C PRINT 405
C PRINT 566,ITOWER,IPROB
C PRINT 567
900 CONTINUE
C ITCODE IS A DISTILLATE CODE.
C ITCODE=1 FOR AN ALL VAPOR DISTILLATE
C ITCODE=2 FOR A LIQUID-VAPOR DISTILLATE
C ITCODE=3 FOR AN ALL LIQUID DISTILLATE
C ITCODE=4 FOR A SUBCOOLED LIQUID DISTILLATE
C-----
C IFCODE IS A FEED CODE
C IFCODE=0 FOR A SUPERHEATED FEED
C IFCODE=1 FOR A DEW POINT FEED
C IFCODE=2 FOR A FLASHED FEED
C IFCODE=3 FOR A BUBBLE POINT FEED
C IFCODE=4 FOR A SUBCOOLED FEED
C-----
C ITCODE IS A TYPE CODE
C ITCODE= 1 FOR A SINGLE COLUMN---SOLVED BY SOREL
C ITCODE=2 FOR A NORMAL DOUBLE COLUMN-B(1)=F(2)
C ITCODE=3 FOR A NORMAL DOUBLE COLUMN-D(1)=F(2)
C ITCODE=4 FOR LIMB"DOUBLE COLUMN"-D(1)=REFLUX(2)
C-----
C GO TO (301,302,303,304),ITCODE
301 PRINT 531
C PRINT 800
C DSPLIT=1.0
C GO TO 305

```



```

302 PRINT 532
PRINT 800
READ 530,DSPLIT
C DSPLIT=DV/DIST=FACTION VAPOR DISTILLATE
GO TO 305
303 PRINT 533
PRINT 800
DSPLIT=0.0
GO TO 305
304 PRINT 534
PRINT 800
DSPLIT=0.0
GO TO 305
305 CONTINUE
IF(ITOWER.EQ.2) GO TO P15
C
C -----
C ***** BASIC PARAMETERS*****
READ 501,FRATE,XF1
C FRATE IN LB.-MOLE/HR. UNITS ONLY!!!
P15 READ 530,REACTR
P16 READ 502,DELTA P,CONDPR,REBPR
READ 530,PREF
C PREF= REFERENCE PRESSURE FOR EQUILIBRIUM DATA
C DELTA P=PRESSURE DROP/STAGE; REACTR=REFLUX FACTOR--R=REACTR*RMIN
C CONDPR AND REBPR ARE CONDENSER AND REBOILER PRESSURE DROPS
C RESPECTIVELY
C
C -----
C ***** ALL PRESSURE DROPS SHOULD BE EXPRESSED AS POSITIVE
C NUMBERS---PSTIA; ALL TEMPERATURES IN DEGREES FAHRENHEIT
C *****AVERAGE PRESSURE IN SECOND COLUMN (PTOP+PBOT)/2. MUST
C BE LESS THAN CONDENSER PRESSURE OF FIRST COLUMN*****
C
C -----
READ 501,TOL,TOLCA
C **** TOL= TOLERANCE--BUBBLE, DEW PTS.---COMPONENT SUMMATION=1
C ***** TOLCA=TOLERANCE ON COMPOSITION---MOLE FRACTION
TOLH=0.001
READ 503,TTOP,PTOP,TBOT,PBOT
READ 501,ZD1,XB1
PFEED=(PTOP+PBOT)/2.
XTRA=XB1
IF(ITOWER.EQ.2) GO TO 5656
DIST=FRATE*(YF1-XB1)/(ZD1-XB1)
BOT=FRATE-DIST
BOTV=0
C
C -----
C INPUT OF BASIC DATA
C ENTHALPY INPUT IN BTU/LB-MOLE UNITS ONLY !!!
5656 READ 504,(TEMP(I),HL(1,I),HL(2,I),HV(1,I),HV(2,I)),I=1,2)
READ 505,(TEQ(I),EK(1,I),EK(2,I)),I=1,2)
C HL AND HV ARE FOR BOTH COMPONENTS AT TEMP(1) AND TEMP(2);
C EK(1) AND EK(2) AT TEQ(1) AND TEQ(2).
C
C -----
C ***** INPUT DATA PRINT OUT*****
IF(ITOWER.EQ.2) GO TO 3475
3475 PRINT 506
DIST=FRATE*(YF1-XB1)/(ZD1-XB1)
BOT=FRATE-DIST
BOTV=0

```

```

PRINT 800
PRINT 527
PRINT 400
PRINT 529,FRATE,XF1,YB1,DIST,DSPLIT,7D1
IF(IPRESS.GT.1) GO TO 2100
PRINT 507,DELTA P,CONDPP,REBPP
IF(ITOWER.EQ.2) GO TO 3575
C
-----
C
C      CALCULATION OF EQUILIBRIUM CONSTANTS
3275  DO 2 I=1,2
      R(I)=LOG(EK(I,1)/EK(I,2))*(TEQ(1)+460.)*(TEQ(2)+460.)/
      % (TEQ(2)-TEQ(1))
      A(I)=LOG(EK(I,1)*PREF)-R(I)/(TEQ(1)+460.)
2     CONTINUE
C
-----
C
C      CALCULATION OF ENTHALPY CONSTANTS
DO 3 I=1,2
PHL(I)=(HL(I,2)-HL(I,1))/(TEMP(2)-TEMP(1))
AHL(I)=HI(I,1)-BPL(I)*(TEMP(1)+460.)
BHV(I)=(HV(I,2)-HV(I,1))/(TEMP(2)-TEMP(1))
AHV(I)=HV(I,1)-BHV(I)*(TEMP(1)+460.)
3     CONTINUE
PRINT 513,ITOWER
PRINT 800
PRINT 514
DO 1000 I=1,2
PRINT 515,I,A(I),PREF,AHL(I),AHV(I)
PRINT 516,I,R(I),PREF,BHL(I),BHV(I)
1000  CONTINUE
PRINT 800
PRINT 400
IF(ITOWER.EQ.2) GO TO 3375
C
-----
C
C      CALCULATION OF FEED CONDITION AND REFLUX
3575  IPASS=1
C
C      IPASS IS A VARIABLE TO DETERMINE CALCULATIONAL CONTROL.
C      PFEED=(PTOP+PBOT)/2.
2100  CONTINUE
IF(ITOWER.EQ.1) GO TO 637
CALL BUDBPLE(PFEED,XF1,TOL,TLO)
CALL DEWPT(PFEED,XF1,TOL,TH1)
IF(TH1-TFEED) 621,622,623
623  IF(TLO-TFEED) 624,625,627
621  IFCODE=0
      GO TO 637
622  IFCODE=1
      GO TO 637
624  IFCODE=2
      GO TO 637
625  IFCODE=3
      GO TO 637
627  IFCODE=4
      GO TO 637
637  CONTINUE
IF(IFCODE.EQ.0) GO TO 610
CONTINUE
GO TO (611,612,613,614),IFCODE
610  CALL DEWPT(PFEED,XF1,TOL,TFSUDP)
CALL FDFLSH(TFSUDP,PFEED,XF1,XFEED,YFEED)
IF(IPASS.GT.1 .OR. ITOWER.EQ.2) GO TO 630

```

```
READ 530,TFEED
GO TO 630
611 CALL DEWPT(PFEED,XF1,TOL,TFDEW)
    TFEED=TFDEW
    GO TO 625
612 CONTINUE
    IF(IPASS.GT.1 .OR. ITOWER.EQ.2) GO TO 625
    READ 530,TFEED
    GO TO 625
613 CALL BUBBLE(PFEED,XF1,TOL,TFBUB)
    TFEED=TFBUB
    GO TO 625
614 CALL BUBBLE(PFEED,XF1,TOL,TFSUDD)
    CALL FDFLSH(TFSUDD,PFEED,XF1,XFEED,YFEED)
    IF(IPASS.GT.1 .OR. ITOWER.EQ.2) GO TO 630
    READ 530,TFEED
    GO TO 630
625 CALL FDFLSH(TFEED,PFEED,XF1,XFEED,YFEED)
630 VV=((XF1-XFEED)/(YFEED-XFEED))*FRATE
    HFEED=VV*HVAVG(YFEED,TFEED)+(FRATE-VV)*HLAVG(XFEED,TFEED)
    HFLIQ=(FRATE-VV)*HLAVG(XFEED,TFEED)
    HFVAP=VV*HVAVG(YFEED,TFEED)
    IF(IFCODE.EQ.0) GO TO 640
    CONTINUE
    GO TO (641,642,643,644),IFCODE
640 PRINT 650
    GO TO 660
641 PRINT 651
    GO TO 660
642 PRINT 652
    GO TO 660
643 PRINT 653
    GO TO 660
644 PRINT 654
660 CONTINUE
    PRINT 552,FRVAP
    PRINT 400,XFEED,YFEED,HFEED,TFEED
```

C-----
C STORAGE OF CONSTANTS FOR TOWER

```
S(ITOWER,1)=FRATE
S(ITOWER,2)=XF1
S(ITOWER,3)=DELTA P
S(ITOWER,4)=CONDPD
S(ITOWER,5)=REBPD
S(ITOWER,6)=PREF
S(ITOWER,7)=TOL
S(ITOWER,8)=TOLDA
S(ITOWER,9)=TOLH
S(ITOWER,10)=TTUP
S(ITOWER,11)=PTUP
S(ITOWER,12)=TRBT
S(ITOWER,13)=PRBT
S(ITOWER,14)=ZD1
S(ITOWER,15)=XB1
S(ITOWER,16)=A(1)
S(ITOWER,17)=A(2)
S(ITOWER,18)=B(1)
S(ITOWER,19)=B(2)
S(ITOWER,20)=AHL(1)
S(ITOWER,21)=AHL(2)
```

```

S(ITOWER,22)=BHL(1)
S(ITOWER,23)=BHL(2)
S(ITOWER,24)=AHV(1)
S(ITOWER,25)=AHV(2)
S(ITOWER,26)=BHV(1)
S(ITOWER,27)=BHV(2)
S(ITOWER,28)=TFEED
S(ITOWER,29)=IFCODE
IF(ITCODE.EQ.4.AND.ITOWER.EQ.2) GO TO 620
CONTINUE
IF(IFCODE.EQ.0 .OR. IFCODE.EQ.4) GO TO 635
CALL KEFLUX(XF1,ZD1,RMIN,R,TFEED,PFEED)
GO TO 630
635 CALL KEFLUX(XF1,ZD1,RMIN,R,TFEED,PFEED)
630 CONTINUE
PRINT 517,RMIN,R
PLRW=0.9*R
PHIGH=1.1*R
C
-----
C CALCULATION ---CONDENSER AND TOP STAGE
PCOND=PTOP-CONDPD
55 CONTINUE
DIST=FRATE*(YF1-XB1)/(ZD1-XB1)
RDT=FRATE-DIST
RUTV=0
GO TO (51,52,53,54),TDCODE
51 DV=DIST
DL=0
CALL DEWPT(PCOND,ZD1,TCL,TCOND)
GO TO 50
52 DV=DTST*DSPLIT
DL=DTST-DV
CALL FLASH(DSPLIT,PCOND,ZD1,TCOND)
GO TO 50
53 DL=DTST
DV=0
CALL BUBBLE(PCOND,ZD1,TUL,TCOND)
GO TO 50
54 DV=0
DL=DTST
CALL BUBBLE(PCOND,ZD1,TUL,TSEUDU)
CALL FFFLASH(TSEUDU,PCOND,ZD1,XD,YD)
IF(IPASS.GT.1) GO TO 65
READ 530,TCOND
GO TO 65
50 CALL FFFLASH(TCOND,PCOND,ZD1,XD,YD)
65 CONTINUE
PRINT 553,FRVAP
PRINT 800
PRINT 500
PRINT 500
PRINT 510,TTOP,TRUT,TFEED,TCOND
PRINT 511
PRINT 512,PTOP,PRUT
PRINT 800
1600 CONTINUE
YY=(YD*(P*DIST+DL)+DV*YD)/(DIST+P*DIST)
N=1
Y(N)=YY
CALL DEWPT(PTOP,YY,TOL,TD)

```

```

T(N)=TDP
Y(N)=YY/FQK(TDP,PTDP,1)
DIST=PL*HLAVG(XD,TCUND)+DV*HVAVG(YD,TCUND)
OC=R*DIST*HLAVG(XD,TCUND)+DISTH-DIST*(R+1.)*HVAVG(YY,TDP)
RATEV(N)=DIST*(R+1.)
P(N)=PTDP

```

```

821 CONTINUE
IF(IPASS.GT.1) GO TO 1400

```

C -----
C PLATE TO PLATE CALCULATION IN RECTIFYING SECTION---(TOP DOWN)

```

8 N=N+1
  CORECT=0
  CALL RTPDOWN(N)
  IF(X(N)-YFEED) 9,9,8
9 CONTINUE
  NRECT=N-1
  NFD=NRECT+1
  NFD1=NFD+1
  VPLACE=RATEV(NRECT+1)
  PLACE1=VPLACE
  TPLACE=T(NRECT+1)
  YPLACE=Y(NRECT+1)
  XPLACE=X(NRECT+1)
  PPLACE=P(NRECT+1)
  IF(IPASS.EQ.1) GO TO 700
1400 CONTINUE
  NPLACE=NRECT+1
  DO 1090 N=2,NPLACE
  CORECT=0
1090 CALL RTPDOWN(N)
  N=NPLACE
1500 CONTINUE
  CALL FTPDOWN(N,YFEED,VV,HFVAP)
  N=N+1
  CALL FTPDOWN(N,XFEED,FRATE-VV,HFLIQ)
  N=N+2
  NN=N
  IF(NN=NTOTAL) 3876,3878,3879
3879 CONTINUE
  CORECT=RCBPD-DELTAP
  CALL FTPDOWN(N-2,XFEED,FRATE-VV,HFLIQ)
  GO TO 3877
3876 CORECT=0
  NP=NTOTAL-1
  DO 1070 N=NN,NP
1070 CALL STPDWN(N)
3878 N=NTOTAL
  CORECT=RCBPD-DELTAP
  CALL STPDWN(N)
3877 CORECT=0
  RATEI(NTOTAL)=FRATE-DIST
  IF(IPASS.EQ.3) GO TO 700
  CONTINUE
  IF(IPASS.GT.3) GO TO 1351
  PRINT 409
  PRINT 564,IPASS
  GO TO 705
706 PRINT 409
  PRINT 412
1351 PRINT 413,IPASS,N,X(NTOTAL)

```

```

705  CU TO 137
    PRINT 2000,R
    IF(IPASS.GF.3) GO TO 1350
    PRINT 510
    PRINT 503
    PRINT 502,TCOND,PATEV(1),UV,PCOND
    DO 1071 N=1,NTOTAL
1071  PRINT 520,N,T(N),RATEL(N),RATEV(N),P(N)
    PRINT 501
    PRINT 521
    DO 1072 N=1,NTOTAL
1072  PRINT 522,N,Y(N),Y(N)
    PRINT 501
    PRINT 526,IPASS
    GO TO 150
1350 PRINT 508,X(NTOTAL)
    GO TO 150
700  CONTINUE

```

```

C
C -----
C  CALCULATION OF REBOILER DUTY.
    PP=PBUT+REBPD
    CALL BUBBLE(PP,XB1,TOL,TREB)
    DDT=FRATE-DIST
    CR=DDT*(1+(FRATE-DIST)*HLAVG(XB1,TREB))-HFEEB-OC
    RDTM=(FRATE-DIST)*HLAVG(XB1,TREB)
    M=NRECT+1
    MM=NRECT+1
    T(M)=TREB
    X(M)=XB1
    Y(M)=EQN(TREB,P,1)*X(M)
    RATEL(M)=FRATE-DIST
    P(M)=PP
    CORRECT=REBPD-DELTAP

```

```

C
C -----
C  PLATE TO PLATE CALCULATIONS IN STRIPPING SECTION---(BOTTOM UP)
12  M=M+1
    CALL SBOTUP(K)
    CORRECT=0
    IF(YFEEB-Y(M)) 13,13,12
13  CONTINUE
    NSTRIP=A-NRECT-1
    NTOTAL=NRECT+NSTRIP
    PLACF2=RATEL(NTOTAL+1)
    NREV=NTOTAL
    J=NSTRIP
    K=MM
    KK=1
1005  EXTRA1=RATEL(K)
    EXTRA2=RATEV(K)
    EXTRA3=T(K)
    EXTRA4=X(K)
    EXTRA5=Y(K)
    EXTRA6=P(K)
    RATEL(K)=RATEL(NREV)
    RATEV(K)=RATEV(NREV)
    T(K)=T(NREV)
    X(K)=X(NREV)
    Y(K)=Y(NREV)
    P(K)=P(NREV)
    RATEL(NREV)=EXTRA1

```

```
RATEV(NKREV)=EXTRA2
T(NREV)=EXTRA3
X(NREV)=EXTRA4
Y(NREV)=EXTRA5
P(NREV)=EXTRA6
K=K+1
KK=KK+1
NREV=NREV-1
IF(KK-(J/2)) 1005,1005,1006
1006 PRINT 400
PRINT 510
PRINT 410
PRINT 510
PRINT 500
PRINT 500,TCOND,DL,DV,PCOND
DO 1001 N=1,NRECT
1001 PRINT 520,N,T(N),RATEL(N),RATEV(N),P(N)
PRINT 600,PLACE1
PRINT 521
DO 1002 N=1,NRECT
1002 PRINT 520,N,X(N),Y(N)
PRINT 520,N,NRECT
PRINT 400
PRINT 411
PRINT 510
PRINT 500
DO 1003 M=MM,NTOTAL
1003 PRINT 520,M,T(M),RATEL(M),RATEV(M),P(M)
PRINT 501
PRINT 600,PLACE2
PRINT 521
DO 1004 M=MM,NTOTAL
1004 PRINT 520,M,X(M),Y(M)
PRINT 501
PRINT 524,NSTRIP
PRINT 525,NTOTAL
PRINT 526,IPASS
IPASS=IPASS+1
PDRDP=NTOTAL-2
PBDP=PTOP+DELTAP*PDRDP
PRINT 400
PRINT 600
TTOP=T(1)
TBDP=T(NTOTAL-1)
PFFDP=(2.*P(NTOTAL)+DELTAP)/2.
GO TO 2100
150 PRINT 800
157 IPASS=IPASS+1
YXX=Y(NTOTAL)
IF(IPASS.GT.3) GO TO 1091
P=PLPW
GO TO 1600
1091 IF(WAYA(YXX,YB1,TULUA,P,RHIGH,3)) 1600,1000,9999
1900 PRINT 800
RR=R
PRINT 400
PRINT 1100,ITOWER
PRINT 2007,NFD,NFDL
PRINT 2001,RLW,P,RHIGH
PRINT 1101
```

```

PRINT 565
PRINT 1103,TCUND,PCUND,DL,DV,XD,YD
DO 1901 N=1,NTOTAL
1901 PRINT 1102,N,T(N),P(N),RATEL(N),RATEV(N),X(N),Y(N)
PRINT 561
PRINT 800
PRINT 1105
PRINT 1073
TRFB=T(NTOTAL)
XB1=Y(NTOTAL)
YB1=Y(NTOTAL)
ZB1=XB1
RPTIM=(PFRATE-DIST)*HLAVG(XB1,TRFB)
TRFB1=TRFB
RPTIM1=BOTTH
RPT1=BOT
RPTV1=BOTV
QR=DISTH+BOTTH-HFEED-QC
PRINT 1106,HFEED,QR
SUMIN=HFEED+QR
PRINT 1107,SUMIN
PRINT 1108,DISTH,BOTTH,QC
SUMOUT=DISTH+BOTTH+ABS(QC)
PRINT 1109,SUMOUT
PRINT 1079,ITOWER
IF(ITCODE.EQ.1) GO TO 190
QC1=ABS(QC)
IPASS=1
9713 ITOWER=ITOWER+1
IF(ITOWER.EQ.3) GO TO 190
PRINT 400
PRINT 566,ITOWER,IPKPB
PRINT 567
IF(IMD.GT.0) GO TO 4000
4001 PFEED=(PTOP+PBOT)/2.
CONTINUE
IF(IMD.GT.0) GO TO 3375
CONTINUE
GO TO (190,572,573,574),ITCODE
572 PRINT 582
GO TO 575
573 PRINT 583
GO TO 575
574 PRINT 584
575 CONTINUE
GO TO (190,3175,3175,816),ITCODE
3375 CONTINUE
C
C VALVE CALCULATIONS
GO TO (190,810,811,810),ITCODE
810 CALL VALVE(PFEED,TRFB1,BOTTH1,RPT1,BOTV1,ZB1,YB1)
FRATE=RPT1+BOTV1
XF1=(BOT1*ZB1+BOTV1*YB1)/FRATE
XB1=YTRA
TFEED=TRFB1
HFEED=BOTTH1
HFIN=HFEED
IF(ITCODE.EQ.2) GO TO 3475
3675 CALL VALVE(PTOP,TCUND,DISTH,DL,DV,XD,YD)
RTLO=DL

```



```

      PD=DI*HLAVG(XD,TCUND)
      YD=XD
      GO TO 3475
811  CALL VALVE(FFEED,TCUND,DISTH,DL,DV,XD,YD)
      FRATE=DL+DV
      YF1=(DL*XD+DV*YD)/(DL+DV)
      TFEED=TCUND
      HFEED=DISTH
      GO TO 3475

```

```

C
-----
9999  PRINT 99999
      PRINT 2001,KLOW,P,RHIGH
      IF(XXX-XF1) 9888,1900,9889
9888  P=RLOW
      RLOW=0.9*R
      RHIGH=1.1*R
      P=RLOW
      IF(IPASS.LT.30) GO TO 1600
      CONTINUE
      GO TO 190
9889  P=RHIGH
      RLOW=0.9*R
      RHIGH=1.1*R
      P=RLOW
      IF(IPASS.LT.30) GO TO 1600
      CONTINUE
      GO TO 190

```

```

C
-----
C  CALCULATIONS IN THE ABSORBER SECTION
820  OR=QCI
827  BDT=(FRATE*(ZD1-YF1)+KTLO*(ZD1-XC))/(ZD1-XF1)
823  PP=BDT+PERPD
      CALL DEWPT(PP,XB1,TOL,TREB)
      BDTTH=BDT*HVAVG(XB1,TREB)
      T(1)=TREB
      Y(1)=XB1
      P(1)=PP
      Y(2)=XB1
      CALL BU&PLE(PBDT,XB1,TOL,TT)
      T(2)=TT
      RATEV(1)=(BDTTH-OR-BDT*HLAVG(XB1,TT))/(HLAVG(XB1,TT)-HVAVG(XB1,
% TREB))
      RATEI(2)=BDT+KATEV(1)
      P(2)=PBDT
      Y(2)=EOK(TT,PBDT,1)*Y(2)
      M=2
      IF(INDEX.GF.1) GO TO 8719
2500  M=M+1
      CORRECT=0
      CALL SRDTUP(M)
      IF(X(M).EQ.X(M-1).AND.Y(M-1).EQ.Y(M-2)) GO TO 2504
      CONTINUE
      IF(YFEED-Y(M)) 2501,2501,2500
2501  CONTINUE
      M=M-1
      M=M+2
2504  M=M-2
      MFD=M
      MFDI=MFD+1
      CALL FPDUP(M,XFEED,FRATE-VV,HFLTQ)

```

```

M=M+1
CALL FROTOP(M,YFEED,VV,HFVAP)
M=M+1
2502 M=M+1
CALL RROTOP(M)
IF(M.GT.99) GO TO 190
IF(X(M)-Y0) 2502,2503,2503
2503 CONTINUE
MTOT=M-1
PRINT 409
8735 PRINT 608
405 CALL RROTOP(MTOT+1)
VOVHDDQ=RATEV(MTOT)*HVAVG(Y(MTOT),T(MTOT))
ZLIQQ=PATEL(MTOT+1)*HLAVG(X(MTOT+1),T(MTOT+1))
QVALIH=FRATE+RATEL(MTOT+1)-BPT-RATEV(MTOT)
QVALIC=FRATE*XF1+RATEL(MTOT+1)*X(MTOT+1)-BPT*XB1-RATEV(MTOT)*
%Y(MTOT)
IF(INDEX.GE.1) GO TO 8991
8993 PRINT 1101
PRINT 565
IF(INDEX.GE.1) GO TO 8994
PRINT 609,TRCB,P(1),RDT,RATEV(1),XP1,Y(1)
DO 873 M=2,MTOT
873 PRINT 1102,M,T(M),P(M),RATEL(M),RATEV(M),X(M),Y(M)
PRINT 402
IF(INDEX.GE.1) GO TO 8994
CONTINUE
IF(IPBL.FQ.1) GO TO 8994
IPRESS=IPRESS+1
IF(INDEX.GE.1) GO TO 8737
PF1=PFEED
PBPT=P(2)
PTOP=P(MTOT)
PFEED=P(MFD)
DIFF=ABS(PF1-PFEED)
IF(DIFF.IT,0.01) GO TO 8737
PRINT 402
PRINT 605
PRINT 2005,IPRESS
PRINT 2007,MFD,MFD1
IF(IPRESS.GT.30) GO TO 190
CONTINUE
IF(DIFF.GT.0.01) GO TO 810
8737 CONTINUE
ICOR=IPRESS-1
ISUM=INDEX+ICOR
PRINT 402
GO TO 8991
8994 PRINT 1105
PRINT 800
PRINT 2002,HFIN,QR,ZLIQQ
SUMIN=HFIN+QR+ZLIQQ
PRINT 1107,SUMIN
PRINT 2003,BPTTH,VOVHDDQ
SUMOUT=BPTTH+VOVHDDQ
PRINT 1109,SUMOUT
PRINT 800
PRINT 1059
PRINT 1060
GO TO 8725

```

```

8991 CONTINUE
    ISUM=INDEX+ICUP
    IF(INDEX.GE.1) GO TO 8992
    PRINT 409
    PRINT 590
    PRINT 591
8992 PRINT 592,ISUM,RTLO,RATEL(MTOT+1),OK1,OK
8990 CONTINUE
    DELTAH=((RTLO+FRATE-PUT)*HVAVG(Y(MTOT),T(MTOT))-VOVHDQ)
    OHIGH=OK+DELTAH
    INDEX=INDEX+1
8717 IF(WAYA(HO-ZLIQ,0.,HO/100.,OR,OHIGH,3)) 827,8718,9173
8719 DO 8720 M=3,MFD
8720 CALL SUBTOP(M)
    CONTINUE
    CALL FROTUP(MFD,XFEED,FRATE-VV,HFVAR)
    M=MFD
    M=M+1
    CALL FROTUP(M,YFEED,VV,HFVAR)
    M=M+2
    DO 8730 N=M,MTOT
8730 CALL RBOTUP(N)
    CONTINUE
    GO TO 405
9173 PRINT 9115
    GO TO 190
8718 CONTINUE
    IDBL=1
    INDEX=0
    PRINT 403
    PRINT 404
    PRINT 2007,MFD,MFD1
    GO TO 8993
8725 CONTINUE
    ITOWER=ITOWER-1
    OR2=OR
    IDBL=0
    IPRESS=1
    INDEX=0

```

C

C-----RESTORATION OF CONSTANTS

```

4000 GRATE=S(ITOWER,1)
    XE1=S(ITOWER,2)
    DELTAP=S(ITOWER,3)
    CONDPD=S(ITOWER,4)
    REBPD=S(ITOWER,5)
    PRFF=S(ITOWER,6)
    TOL=S(ITOWER,7)
    TOLDA=S(ITOWER,8)
    TULH=S(ITOWER,9)
    TTOP=S(ITOWER,10)
    RTOP=S(ITOWER,11)
    TBNP=S(ITOWER,12)
    PBNP=S(ITOWER,13)
    ZDI=S(ITOWER,14)
    YBI=S(ITOWER,15)
    A(1)=S(ITOWER,16)
    A(2)=S(ITOWER,17)
    B(1)=S(ITOWER,18)
    B(2)=S(ITOWER,19)

```

AHL(1)=S(ITOWER,20)
AHL(2)=S(ITOWER,21)
RHL(1)=S(ITOWER,22)
RHL(2)=S(ITOWER,23)
AHV(1)=S(ITOWER,24)
AHV(2)=S(ITOWER,25)
RHV(1)=S(ITOWER,26)
RHV(2)=S(ITOWER,27)
TFEED=S(ITOWER,28)
TFCODE=S(ITOWER,29)

C
C INTER-COLUMN CONVERGENCE
IF(ITOWER.EQ.2) GO TO 4001
CONTINUE
IF(IND.GT.0) GO TO 20
RFACTR=((BR+1.)*QR/QC1)-1./RMIN
GO TO 58
20 CONTINUE
IF(ITRY.EQ.3) GO TO 23
CONTINUE
IF(ITRY.EQ.4) GO TO 24
CONTINUE
IF(QR2-QC1) 21,59,22
21 CONTINUE
IF(ITRY.EQ.2) GO TO 23
ITRY=1
XB1H=XB1+.01
XB1L=XB1
XB1=XB1H
GO TO 58
22 CONTINUE
IF(ITRY.EQ.1) GO TO 24
ITRY=2
XB1L=XB1-.01
XB1H=XB1
XB1=XB1L
GO TO 58
23 CONTINUE
ITRY=3
IF(WAYA(QC1,QR2,TULH*ABS(QR2),XB1,XB1H,4)) 58,59,190
24 CONTINUE
ITRY=4
IF(WAYA(QC1,QR2,TULH*ABS(QR2),XB1,XB1L,4)) 58,59,190
58 IND=IND+1
IF(IND.GT.10) GO TO 190
CONTINUE
GO TO 3576
59 PRINT 409
PRINT 407
IF(ICNV.EQ.1) GO TO 190
ICNV=1

C
C DATA PRINTOUT---SECOND COLUMN
3576 DIST=FRATE*(XF1-XB1)/(Z01-XB1)
PDT=FRATE-DIST
PDTV=0
PRINT 400
PRINT 506,ITOWER,IPKQB
PRINT 800
PRINT 527

PRINT 400
PRINT 528,FRATE,XF1,XB1,DIST,DSPLIT,ZD1
PRINT 507,DELTA P,CONDPR,REBPR
GO TO 3575

```

C-----0
C ***** FORMAT SECTION *****
400  FORMAT(1+1,5X,'MOLS/HOUR',21X,'MOLS/HOUR',/)
402  FORMAT(1+1,1X,'TOP')
403  FORMAT(101,20X,'PRESSURE VARIATIONS HAVE BEEN DAMPED',/)
406  FORMAT(1X,20X,'THE SECOND TOWER IS INDEPENDENTLY CLOSED',/)
407  FORMAT(21X,'FINAL CONVERGENCE HAS BEEN ACHIEVED FOR BOTH TOWERS',
%/,/)
408  FORMAT(11,15X,'XFEED=',F9.5,5X,'YFEED=',F9.5,5X,'HFEED=',E15.8,
%5X,'TFEED=',F10.5,/)
409  FORMAT(111,6(/),80X)
410  FORMAT(15X,'RECTIFYING SECTION',/)
411  FORMAT(15X,'STRIPPING SECTION',/)
412  FORMAT(5X,'PASS',3X,'REFLUX RATIO',3X,'BOTTOMS COMP.',/)
413  FORMAT(7X,I2,5X,F10.5,5X,F10.7)
501  FORMAT(2F12.5)
502  FORMAT(3F12.5)
503  FORMAT(4F12.5)
504  FORMAT(5F12.5)
505  FORMAT(3F12.5)
506  FORMAT(101,20X,'INPUT DATA USED IN CALCULATIONS',/)
507  FORMAT(5X,'PRESSURE DROP/STAGE=',F6.4,5X,
% 'CONDENSER PRESSURE DROP=',F6.4,5X,
% 'REBOILER PRESSURE DROP=',F6.4,/)
508  FORMAT(101,25X,'TEMPERATURES---DEGREES FAHRENHEIT',/)
509  FORMAT(9X,'TOP',9X,'BOTTOM',6X,'FEED',8X,'CONDENSER',/)
510  FORMAT(5X,4(F11.5,1X),/)
511  FORMAT(20X,'PRESSURES---PSIA',/)
512  FORMAT(5X,'PTOP=',F12.5,5X,'PBOTTOM=',F12.5,/)
513  FORMAT(101,35X,'*****CONSTANTS***** TOWER NUMBER',I2)
514  FORMAT(5X,'EQUILIBRIUM',15X,'PRESSURE',14X,'ENTHALPY-LIQUID',
%7X,'ENTHALPY-VAPOR',/)
515  FORMAT(1X,'A',I1,2X,4(F12.5,9X),/)
516  FORMAT(1X,'B',I1,2X,4(F12.5,9X),/)
517  FORMAT(/,2X,'MINIMUM REFLUX =',F12.5,10X,'REFLUX RATIO=',F12.5,
%/)
518  FORMAT(1X,5X,'FIRST PASS---DETERMINATION OF NUMBER OF STAGES',
%/)
519  FORMAT(5X,'STAGE',5X,'TEMPERATURE',5X,'LIQUID RATE',5X,
% 'VAPOR RATE',9X,'PRESSURE')
520  FORMAT(5X,I3,7X,4(F11.5,5X))
521  FORMAT(101,5X,'STAGE',5X,'X(1)',12X,'Y(1)',/)
522  FORMAT(5X,I3,7X,2(F10.7,6X))
523  FORMAT(101,5X,'THE NUMBER OF STAGES IN THE RECTIFYING SECTION',
%ARE',I3,/)
524  FORMAT(101,5X,'THE NUMBER OF STAGES IN THE STRIPPING SECTION',
%ARE',I3,/)
525  FORMAT(101,5X,'THE TOTAL NUMBER OF STAGES IN TOWER ARE',I5,/)
526  FORMAT(101,5X,'PASS NUMBER',I3,' IS COMPLETE')
527  FORMAT(101,5X,'FEED RATE',3X,'XF(1)',4X,'XB(1)',4X,'DIST.RATE',
%2X,'DIST.SPLIT',2X,'ZD(1)',/)
528  FORMAT(5X,F10.5,2(2X,F7.6),2(2X,F10.5),2X,F7.6,/)
529  FORMAT(I2)
530  FORMAT(F12.5)
531  FORMAT(15X,'PARTIAL CONDENSER---ALL VAPOR DISTILLATE.')
532  FORMAT(15X,'TOTAL CONDENSER---ALL LIQUID DISTILLATE!')

```

```

534 FORMAT(15X,'TOTAL CONDENSER---SUBCOOLED DISTILLATE')
552 FORMAT(15X,'THE FRACTION FEED VAPORIZED=' ,F7.4,/)
553 FORMAT(15X,'THE FRACTION DISTILLATE VAPORIZED=' ,F7.4,/)
561 FORMAT(1+1,'RER.')
```

562 FORMAT(3X,'COND. ',5X,4(F11.5,5X))

563 FORMAT(15X,'DEGREES F',7X,'MOLES/HR.',7X,'MOLES/HR.',12X,'PSTA'
%,//)

564 FORMAT(1X,30X,'PASS NUMBER',2X,I2)

565 FORMAT(15X,'DEGREES F',9X,'PSIA',9X,'MOLES/HR.',9X,'MOLES/HR.',
%,//)

566 FORMAT(1X,35X,'COLUMN NUMBER',14,'-----PROBLEM NUMBER',I4)

567 FORMAT(1+1,34X,17('_ '),//)

568 FORMAT(15X,'THE BOTTOMS MOLE FRACTION LIQUID FOR THIS PASS IS',
%F10.7,//)

569 FORMAT(30X,'PASS NUMBER',2X,I2)

582 FORMAT(30X,'DOUBLE COLUMN---BOTTOMS(1)=FEED(2)',//)

583 FORMAT(30X,'DOUBLE COLUMN---DISTILLATE(1)=FEED(2)',//)

584 FORMAT(30X,'AIR PLANT---D(1)=REFLUX(2)',//)

590 FORMAT(1X,15X,'TRIAL',5X,'OVERHEAD FEED',5X,'OVERHEAD FEED',5X,
% 'CONDENSER DUTY(1)',5X,'REBILIER DUTY(2)')

591 FORMAT(28X,'REQUIREDF',11X,'ACTUAL',//)

592 FORMAT(15X,I3,7X,2(F13.7,5X),5X,2(E17.7,5X))

602 FORMAT(10,'THE NET VAPOR ENTERING THE RECTIFYING SECTION IS',
%F11.5,//)

603 FORMAT(10,'THE NET LIQUID ENTERING THE STRIPPING SECTION IS',
%F11.5,//)

605 FORMAT(1X,15X,'REVISED VALUES BASED ON TRUE PRESSURE PROFILE',
%,//)

608 FORMAT(10,30X,'AIR PLANT---SECOND COLUMN---ABSORBER SECTION',//)

609 FORMAT(5X,'KFB. ',5X,6(F11.5,5X))

650 FORMAT(15X,'SUPERHEATED FEED',//)

651 FORMAT(15X,'DEW POINT FEED',//)

652 FORMAT(15X,'FLASHED FEED',//)

653 FORMAT(15X,'BURBLE POINT FEED',//)

654 FORMAT(15X,'SUBCOOLED FEED',//)

800 FORMAT(1+1,80('_ '),//)

1059 FORMAT(30X,'TOWER NUMBER TWO IS COMPLETE')

1060 FORMAT(1+1,30X,28('_ '),//)

1078 FORMAT(1+1,30X,26('_ '))

1079 FORMAT(30X,'TOWER NUMBER',I2,' IS COMPLETE')

1080 FORMAT(1+1,30X,28('_ '),//)

1100 FORMAT(1X,10X,'FINAL CONVERGENCE ACHIEVED ON BOTTOMS
%COMPOSITION ---TOWER NUMBER',I2,//)

1101 FORMAT(5X,'STAGE',5X,'TEMPERATURE',5X,' PRESSURE ',5X,
% 'LIQUID RATE',5X,'VAPOR RATE',5X,' X(COMP.1) ',5X,' Y(COMP.1)')

1102 FORMAT(5X,I3,7X,6(F11.5,5X))

1103 FORMAT(5X,'COND. ',5X,6(F11.5,5X))

1105 FORMAT(30X,'ENTHALPY BALANCE (BTU/HR.)')

1106 FORMAT(5X,'FEED ENTHALPY=' ,E15.8,10X,'REBILIER DUTY=' ,E15.8,//)

1107 FORMAT(25X,'TOTAL ENTHALPY IN =',E15.8,//)

1108 FORMAT(2X,'DISTILLATE ENTHALPY =',E15.8,2X,'BOTTOMS ENTHALPY =',
%F15.8,2X,'CONDENSER DUTY =',E15.8,//)

1109 FORMAT(25X,'TOTAL ENTHALPY OUT =',E15.8,//)

2000 FORMAT(10,10X,'THE VALUE OF THE REFLUX RATIO=' ,F10.5,//)

2001 FORMAT(10,15X,'RLOW=' ,F9.5,5X,' R=' ,F9.5,5X,' RHIGH=' ,F9.5,//)

2002 FORMAT(2X,'FEED ENTHALPY=' ,E15.8, 5X,'REBILIER DUTY=' ,E15.8, 5X,
% 'REFLUX ENTHALPY=' ,E15.8,//)

2003 FORMAT(5X,'BOTTOMS ENTHALPY',E15.8,10X,'TOP PRODUCT ENTHALPY',
%F15.8,//)

2005 FORMAT(30X,'TRIAL NUMBER',I2)

```
2007  FORMAT(20X,'THE FEED IS INTRODUCED BETWEEN STAGES',  
%T2,' AND ',I2,')  
8899  FORMAT(30X,'NO CONVERGENCE',///)  
9115  FORMAT(30X,'NO CONVERGENCE IN SECOND TOWER',//)  
99999  FORMAT(5X,'NO CONVERGENCE-BOTTOMS COMP.-PHIGH,RLW REVISED')  
C
```

```
-----  
190  IPRUB=IPROB+1  
     IF(IPROB.LE.NPROB) GO TO 1605  
     STOP  
     END
```

```

SUBROUTINE VALVE(PRESS,TTT,ENTLPHY,ZLIQ,VAP,XV,YV)
COMMON /PVAP
COMMON A(2),B(2),PCON(2),FRATE,REACTR,DIST
COMMON DELTAP,TTOP,TPUT
COMMON APL(2),BHI(2),AHV(2),BHV(2)
COMMON /TDLTOL/TOL,TOLR,TOLRA
COMMON/VARBL5/ X(100),Y(100),T(100),PAEL(100),RATEV(100)
COMMON/VARPL5/ P(100)
COMMON/CONREP/ DI,DV,XP,YD,QC,QR,DISTH,BOTTH,XP1,XF1,TFEED
COMMON/CONPER/ TCOND,XFEED,YFEED,HFEED,VV,PUT
COMMON/PSSR/ CONDDP,REBPD,CORRECT
C SUBROUTINE TO CALCULATE TEMPERATURE AND COMPOSITION ON UNKNOWN
C SIDE OF EXPANSION VALVE (CONSTANT ENTHALPY ASSUMED ACROSS VALVE).
C
-----
I VALVE=1
RATE=ZLIQ+VAP
Z=(ZLIQ*XV+VAP*YV)/RATE
C PRINT 541,PRESS,TTT,ENTLPHY,ZLIQ,VAP
C PRINT 541,XV,YV,RATE,Z,ENTLPHY
541 FORMAT(5X,'I VALVE',3X,'SE20.7')
CALL BUBBLEF(PRESS,Z,TOL,TLOW)
CALL DEWPT(PRESS,Z,TOL,THIGH)
4 TTT=TLOW
1 CALL FDFLSH(TTT,PRESS,Z,XV,YV)
VAP=RATE*(Z-XV)/(YV-XV)
ZLIQ=RATE-VAP
HTDT=(RATE-VAP)*HLAVG(XV,TTT)+VAP*HVAVG(YV,TTT)
IF(WAYA(HTDT,ENTLPHY,TOLH*ABS(ENTLPHY),TTI,THIGH,1)) 1,2,3
2 RETURN
3 TLOW=0.9*TLOW
THIGH=1.1*THIGH
I VALVE=I VALVE+1
IF(I VALVE-30) 4,4,5
5 PRINT 6,TTT,XV,YV,HTDT
6 FORMAT(30X,'THE VALVE WILL NOT CONVERGE---T='F12.5,2X,'X='F9.5,
%2X,'Y='F9.5,2X,'H='F14.7,/)
RETURN
END

```



```
SUBROUTINE RTRPDWN(N)
COMMON FRVAP
COMMON A(2),B(2),PCUM(2),FRATE,KFACTR,DIST
COMMON DELTAP,TTOP,TRUT
COMMON APL(2),BHL(2),AHV(2),BHV(2)
COMMON /TOL/ TOL,TOLH,TOLUA
COMMON/VARBL/ X(100),Y(100),T(100),RATEL(100),RATEV(100)
COMMON/VARBL/ P(100)
COMMON/CONPER/ DL,DV,XD,YD,QC,QK,DISTH,BOTTH,XB1,XF1,TFEED
COMMON/CONPER/ TCUMD,XFEED,YFEED,HFEED,VV,BUT
COMMON/PRSSK/ CUMPD,KEBPD,CORRECT
C PLATE TO PLATE CALCULATION IN RECTIFYING SECTION---(TOP DOWN)
C -----
7 XX=X(N-1)
  YLIN=X(N-1)+.0002
  YY=Y(N-1)
  TT=T(N-1)
  PP=P(N-1)+DELTAP+CORRECT
4 CONTINUE
  CALL DEFWPT(PP,YY,TOL,TRP)
  RATEL(N)=(DL*XD-DL*YY+DV*YD-DV*YY)/(YY-X(N-1))
  RATEV(N)=(DL*XD-DL*X(N-1)+DV*YD-DV*X(N-1))/(YY-X(N-1))
  EQN=RATEV(N)*HVAVG(YY,TRP)-RATEL(N)*HLAVG(XX,TT)+QC
  TOLTI=TOLH*(ABS(QC)+ABS(DISTH))
  IF(WAYA(EQN,DISTH,TOLTI,YY,YLIM,2)) 4,5,9999
5 Y(N)=YY
  T(N)=TRP
  Y(N)=Y(N)/EQK(TRP,PP,1)
  P(N)=PP
  GO TO 2230
9999 PRINT 99999,N,DISTH,EQN,TOLTI
99990 FORMAT(5X,'ERR-RTRPDWN',3X,'STAGE=',I2,'TRUF VALUE=',
  /F15.7,'CALC. VALUE=',F15.7,'TOL=',F10.5,/)
  GO TO 5
2230 RETURN
END
```

```

SUBROUTINE FTPDOWN(N,XYZ,FEED,HF)
COMMON PRVAP
COMMON A(2),B(2),PCUN(2),FRATE,KFACTR,DIST
COMMON DELTAP,TTTP,TBOT
COMMON APL(2),BHL(2),APV(2),PHV(2)
COMMON /TOL/TL/TOL,TOLH,TOLDA
COMMON/VARBL/ X(100),Y(100),T(100),RATEI(100),RATEV(100)
COMMON/VARBL/ P(100)
COMMON/CONREP/ DL,DV,XD,YD,QC,OR,DISTH,BOTTH,XP1,XF1,TFEED
COMMON/CONREP/ TCUNO,XFEED,YFEED,HFEED,VV,BUT
COMMON/PRSSR/ CONDPD,RFBDP,CORRECT
FEED ZONE---TOP DOWN

```

C
C

```

YPLACE=Y(N)
TPLACE=T(N)
VPLACE=RATEV(N)
HPLACE=RATEV(N)*HVAVG(YPLACE,TPLACE)
PPLACE=P(N)
XSTRIP=X(N-1)
STRIPL=RATEI(N-1)
TSTRIP=T(N-1)
HSTRIP=STRIPL*HLAVG(XSTRIP,TSTRIP)
XX=YPLACE/EQK(TPLACE,PPLACE,1)
PP=PPLACE+DELTAP+CORRECT
YY=YPLACE
YLIM=XX+0.0002
710 CONTINUE
CALL DEWPT(PP,YY,TOL,TT)
EQN1=(VPLACE*YPLACE-FEED*XYZ-STRIPL*XSTRIP+(FEED+STRIPL-VPLACE)
%*XX)/(YY-XX)
EQN2=(HPLACE-HF-HSTRIP+(STRIPL+FEED-VPLACE)*HLAVG(XX,TPLACE))
%/(HVAVG(YY,TT)-HLAVG(XX,TPLACE))
DIFF=EQN1-EQN2
C PRINT 540,PP,TT,EQN1,EQN2,DIFF,YY
540 FORMAT(G(F12.6,3X))
IF(WAYA(DIFF,0.,TOLH*ABS(EQN1),YY,YLIM,2)) 710,711,9999
711 T(N)=TPLACE
Y(N+1)=YY
X(N+1)=YY/EQK(TT,PP,1)
T(N+1)=TT
P(N+1)=PP
X(N)=XX
RATEV(N+1)=EQN1
RATEI(N)=RATEI(N-1)-RATEV(N)+FEED+RATEV(N+1)
GO TO 2220
9999 TOLF=TOLH*ABS(EQN1)
PRINT 99990,EQN1,EQN2,DIFF,TOLF
99990 FORMAT(5X,'EOK-FTPDOWN',3X,'EQN1=',E15.7,'EQN2=',F15.7,
%3X,'DIFF=',F10.5,5X,'TOLF=',F10.5,/)
GO TO 711
2220 RETURN
END

```

```

SUBROUTINE STPDWN(N)
COMMON FPVAP
COMMON A(2),P(2),PCON(2),FRATE,REACTR,DIST
COMMON DELTAP,TTOP,TRDT
COMMON AHL(2),BHL(2),AHV(2),PHV(2)
COMMON /TOLTOL/TOL,TOLH,TOLGA
COMMON/VARBL5/ X(100),Y(100),T(100),RATEL(100),RATEV(100)
COMMON/VARBL6/ P(100)
COMMON/CONRES/ DL,DV,XD,YD,QC,QR,DISTH,BOTTH,XB1,XF1,TFEED
COMMON/CONRES/ TCOND,XFEED,YFEED,HFEED,VV,BUT
COMMON/PRSSR/ CUMDPD,REBPD,CORRECT
C PLATE TO PLATE CALCULATION IN STRIPPING SECTION---(TOP DOWN)
C
7 YX=X(N-1)
  YLIM=X(N-1)+.0002
  YY=Y(N-1)
  TT=T(N-1)
  PP=P(N-1)+DELTAP+CORRECT
4 CONTINUE
  CALL DEWPT(PP,YY,TOL,TRDT)
  RATEL(N-1)=(DL*XD-DL*YY+DV*YD-DV*YY+FRATE*YY-FRATE*XF1)/(YY-X(N-1))
  RATEV(N)=(DL*XD-DL*X(N-1)+DV*YD-DV*X(N-1)+FRATE*X(N-1)-FRATE*XF1)
  %/(YY-X(N-1))
  EQN=RATEV(N)*HVAVG(YY,TRDT)-RATEL(N-1)*HLAVG(XX,TT)+QC+HFEED
  TOLT2=TOLH*(ABS(QC)+ABS(DISTH)+ABS(HFEED))
  IF(WAYA(EQN,DISTH,TOLT2,YY,YLIM,2)) 4,5,9999
5 Y(N)=YY
  T(N)=TRDT
  X(N)=Y(N)/EQN(TOP,PP,1)
  P(N)=PP
  GO TO 2230
9999 PRINT 99999,N,DISTH,EQN,TOLT2
99999 FORMAT(5Y,'EPR-STPDWN',3X,'STAGE=',12,'TRUE VALUE=',
  %F15.7,'CALC. VALUE=',F15.7,'TOL=',F10.5,/)
  GO TO 5
2230 RETURN
      END

```

```

SUBROUTINE SROTUP(M)
COMMON FRVAP
COMMON A(2),R(2),PCOH(2),FRATE,KFACTR,DIST
COMMON DELTAP,TTOP,TBOT
COMMON AML(2),BHL(2),AMV(2),BMV(2)
COMMON /TOL/ TOL,TOLH,TOLDA
COMMON/VARPLS/ X(100),Y(100),T(100),RATEL(100),RATEV(100)
COMMON/VARPLS/ P(100)
COMMON/CONREP/ DL,DV,XP,YD,QC,QK,DISTH,BOTTH,XB1,XF1,TFEED
COMMON/CONREP/ TCOND,XFEED,YFEED,HFEED,VM,BOT
COMMON/PSSR/ CUNDPD,REFPD,CORRECT
C PLATE TO PLATE CALCULATIONS IN STRIPPING SECTION-(BOTTOM UP)
C
15  YY=Y(M-1)
    XLIM=Y(M-1)-.0002
    YX=X(M-1)
    TT=T(M-1)
    PP=P(M-1)-DELTAP-CORRECT
10  CONTINUE
    CALL BUUPLE(PP,XX,TUL,TBP)
    RATEL(M)=(BOT)*(XB1-Y(M-1))/(XX-Y(M-1))
    RATEV(M-1)=BOT*(YB1-XX)/(XX-Y(M-1))
    EQN=RATEL(M)*HLAVG(XX,TBP)-RATEV(M-1)*HVAVG(YY,TT)+QP
    TULB1=TULH*(ABS(QK)+ABS(BOTTH))
C   PRINT 540,M,TBP,PP,XX,EQN,BOTTH
540  FORMAT(5X,'SROTUP',3X,I2,2X,5E20.5)
541  FORMAT(5X,F10.5)
    IF(WAYA(EQN,BOTTH,TULB1,XX,XLIM,2)) 10,11,9999
11  X(M)=XX
C   PRINT 541,TULB1
    T(M)=TBP
    Y(M)=EQK(TBP,PP,1)*X(M)
    P(M)=PP
    GO TO 2230
9999 PRINT 99999,M,BOTTH,EQN,TULB1
99999 FORMAT(5X,'ERR-SROTUP',3X,'STAGE=',I2,'TRUE VALUE=',
&F15.7,'CALC. VALUE=',F15.7,'TOL=',F10.5,/)
    GO TO 11
2230 RETURN
END

```

```

SUBROUTINE FRUTUP(M,XYZ,FEED,HF)
COMMON FRVAP
COMMON A(2),B(2),PCOM(2),FRATE,KFACTR,DIST
COMMON DELTAP,TTTP,TBUT
COMMON AHL(2),BHL(2),APV(2),PHV(2)
COMMON /TDLTDL/TDL,TDLH,TDLDA
COMMON/VARPLS/ X(100),Y(100),T(100),RATEL(100),RATEV(100)
COMMON/VARPLS/ P(100)
COMMON/CNTRB/ DL,DV,XD,YD,OC,OK,DISTR,BOTTH,XB1,XF1,TFEED
COMMON/CNTRB/ TCOND,XFEED,YFEED,HFEED,VV,PUT
COMMON/PSSTR/ CONDPO,REBPO,CORRECT
C FEED ZONE---BUTTON UP
C -----
YPLACE=Y(M-1)
TPLACE=T(M-1)
VPLACE=RATEV(M-1)
HPLACE=VPLACE*HVAVG(YPLACE,TPLACE)
XSTRIP=X(M)
STRIPL=RATEL(M)
TSTRIP=T(M)
HSTRIP=STRIPL*HLAVG(XSTRIP,TSTRIP)
PSTRIP=P(M)
YY=EOK(TSTRIP,PSTRIP,1)*XSTRIP
PP=PSTRIP-DELTAP
XX=XSTRIP
XLIM=YY-.0002
C PRINT 540,YPLACE,TPLACE,VPLACE,HPLACE,XYZ,FEED
C PRINT 540,XSTRIP,STRIPL,TSTRIP,HSTRIP,PSTRIP,YY
C PRINT 540,HF,XX,XLIM,XYZ,FEED,HF
710 CONTINUE
CALL DUBPLF(PP,XX,TDL,TT)
EQN1=(STRIPL*XSTRIP-FEED*XYZ -VPLACE*YPLACE+(FEED +VPLACE-STRIP
%L)*YY)/(XX-YY)
EQN2=(HSTRIP-HF -HPLACE+(FEED +VPLACE-STRIPL)*HVAVG(YY,TSTRIP
%)))/(HLAVG(XX,TT)-HVAVG(YY,TSTRIP))
DIFF=EQN1-EQN2
C PRINT 540,PP,TT,EQN1,EQN2,DIFF,XX
540 FORMAT(6(F12.6,3X))
TF(WAYA(DIFF,0.,TDLH*ABS(EQN1),XX,XLIM,2)) 710,711,9999
711 T(M)=TSTRIP
X(M+1)=XX
Y(M+1)=EOK(TT,PP,1)*XX
T(M+1)=TT
P(M+1)=PP
V(M)=YY
RATEL(M+1)=EQN1
RATEV(M)=RATEL(M+1)+FEED +RATEV(M-1)-RATEL(M)
GO TO 2230
9999 TDLF=TDL*ABS(EQN1)
PRINT 9999,EQN1,EQN2,DIFF,TDLF
9999 FORMAT(5X,'ERR-FRUTUP',3X,'EQN1=',E15.7,'EQN2=',E15.7,
%3X,'DIFF=',E10.5,5X,'TDL=',E10.5,/)
GO TO 711
2230 RETURN
END

```

```

SUBROUTINE RBUTUP(M)
COMMON F0VAP
COMMON A(2),P(2),PCDN(2),FRATE,KFACTR,DIST
COMMON DELTAP,TRPP,TRPT
COMMON AHL(2),BHL(2),AHV(2),BHV(2)
COMMON /TOL/ TOL,TOLH,TOLUA
COMMON /VARBLS/ X(100),Y(100),T(100),RATEL(100),RATEV(100)
COMMON /VARBLS/ P(100)
COMMON /CONREP/ DI,DV,XD,YD,QC,QR,DISTH,BOTTH,XB1,XF1,TFEED
COMMON /CONREP/ TOUND,XFEED,YFEED,HFEED,VV,PUT
COMMON /PSSR/ CONDPO,REBPO,CORFCT
C PLATE TO PLATE CALCULATIONS IN RECTIFYING SECTION-(BOTTOM UP)
C
15 YY=Y(M-1)
   YLIM=Y(M-1)-.0002
   YX=X(M-1)
   TT=T(M-1)
   PP=P(M-1)-DELTAP-CORFCT
10 CONTINUE
   CALL BUBBLE(PP,XY,TOL,TBP)
   RATEL(M)=(PUT*(XB1-Y(M-1))+FRATE*(Y(M-1)-XF1))/(XX-Y(M-1))
   RATEV(M-1)=(PUT*(XB1-XX)+FRATE*(YX-XF1))/(XX-Y(M-1))
   EQN=RATEL(M)*HLAVG(XX,TBP)-RATEV(M-1)*HVAVG(YY,TT)+QR+HFEED
   TOLB2=TOLH*(ABS(QR)+ABS(HFEED)+ABS(BOTTH))
C PRINT 540,M,TBP,PP,XY,EQN,BOTTH
C PRINT 540,M,TBP,QR,RATEL(M),RATEV(M-1),HFEED
540 FORMAT(5X,'RBUTUP',3X,I2,2X,5E20.5)
541 FORMAT(5X,F10.5)
   IF(WAYA(EQN,BOTTH,TOLB2,XX,XLIM,2)) 10,11,9999
11 X(M)=XX
C PRINT 541,TOLB2
   T(M)=TRPP
   Y(M)=EQK(TBP,PP,1)*X(M)
   P(M)=PP
   GO TO 2230
9999 PRINT 99999,M,BOTTH,EQN,TOLB2
99999 FORMAT(5X,'EPR-RBUTUP',3X,'STAGE=',I2,'TRUE VALUE=',
%F15.7,'CALC. VALUE=',F15.7,'TOL=',F10.5,/)
   GO TO 11
2230 RETURN
END

```

SUBROUTINE FDFLSH(T,P,Z,X,Y)

COMMON FVAP

C FEED FLASH ROUTINE

C

F1=EQK(T,P,1)

F2=EQK(T,P,2)

X=(1.-F2)/(E1-E2)

Y=E1*X

FVAP=(Z-X)/(Y-X)

RETURN

END

SUBROUTINE REFLOX(ZF1,ZD1,PMIN,R,TFEED,PFEED)

COMMON FRVAP

COMMON A(2),B(2),PCUN(2),PRATE,RFACTR,DIST

C REFLEX RATIO CALCULATION

C

F1=EK(TFEED,PFEED,1)

F2=EK(TFEED,PFEED,2)

SLOPEL=(ZD1-F1*ZF1)/(ZD1-ZF1)

SLOPEV=(ZD1-F2*ZF1)/(ZD1-ZF1/E1)

RMINL=SLOPEL/(1.-SLOPEL)

RMINV=SLOPEV/(1.-SLOPEV)

RMIN=((1.-FRVAP)*RMINL)+(FRVAP*RMINV)

R=RFACTR*RMIN

RETURN

END

```
SUBROUTINE FLASH(SPLIT,P,Z,T)
COMMON /TOL/TOL/TOL
FLASH CALCULATION
C-----
CALL DEWPT(P,Z,TOL,T1)
CALL BUBBLE(P,Z,TOL,T2)
T=T2+0.05
TBIG=T1-0.05
1  F1=EQK(T,P,1)
   F2=EQK(T,P,2)
   A=((7*(F1-F2)/(1.0-F2))-1.0)/(F1-1.0)
   IF(WAYA(A,SPLIT,TOL,T,TBIG,1)) 1,2,3
2  RETURN
3  PRINT 999,T
999  FORMAT(15X,'ERROR IN FLASH CALCULATION---THE LAST TEMPERATURE
      %MASI=F12.7)
      PRINT 99999
99999  FORMAT(10X,'THIS TEMPERATURE GIVES LEAST ERROR AND WILL BE USED
      %TO CONTINUE THE CALCULATIONS')
      RETURN
      END
```

```
SUBROUTINE DEWPT(P,Y,TOL,T)
COMMON SLOP(11),TTOP,TRBT
C DEW POINT CALCULATION
C-----
DT=AMAX1(TRBT-TTOP,50.)
T=TTOP-DT
TRIG=TRBT+DT
1  F1=EQK(T,P,1)
   F2=EQK(T,P,2)
   A=(Y/E1)+(1./E2)-(Y/E2)
   IF(WAYA(A,1.,TOL,T,TRIG,1)) 1,2,3
2  RETURN
3  PRINT 999,T
999  FORMAT(15X,'ERROR IN DEW POINT CALCULATION-THE LAST TEMPERATURE
% WAS',3X,F12.7)
    PRINT 99999
99999 FORMAT(10X,'THIS TEMPERATURE GIVES LEAST ERROR AND WILL BE USED
%TO CONTINUE THE CALCULATIONS')
    RETURN
END
```

```
SUBROUTINE BUBBLE(P,X,TOL,T)
COMMON STOP(11),TTOP,TRBT
C BUBBLE POINT CALCULATION
C -----
DT=AMAX1(TRBT-TTOP,50.)
T=TTOP-DT
TRIG=TRBT+DT
1  E1=EQK(T,P,1)
  E2=EQK(T,P,2)
  A=X*(E1-E2)+E2
  IF(WAYA(A,1.,TOL,1,TRIG,1)) 1,2,3
2  RETURN
3  PRINT 999,T
999  FORMAT(15X,'ERROR IN BUBBLE POINT CALCULATION-THE LAST TEMP. WAS'
%3X,F12.7)
  PRINT 99999
99999 FORMAT(10X,'THIS TEMPERATURE GIVES LEAST ERROR AND WILL BE USED
%TO CONTINUE THE CALCULATIONS!')
  RETURN
  END
```

```
FUNCTION EQK(T,P,J)  
COMMON FRVAP  
COMMON A(2),B(2),PCUM(2)  
CALCULATION OF EQUILIBRIUM CONSTANT
```

C
C

```
-----  
EQK=EXP(A(J)+B(J)/(T+460.))/P  
RETURN  
END
```

FUNCTION HLAVG(X,T)
C CALCULATION OF LIQUID MOLAL AVERAGE ENTHALPY.
C

```
-----  
COMMON FSVAP  
COMMON A(2),B(2),PCDH(2),FRATE,KFACTOR,DIST  
COMMON DELTAP,TTOP,TRBT  
COMMON AHL(2),BHL(2),AHV(2),BHV(2)  
DIMENSION HLIQ(2)  
DO 1 I=1,2  
1 HLIQ(I)=AHL(I)+BHL(I)*(1+460.)  
HLAVG=X*(HLIQ(1)-HLIQ(2))+HLIQ(2)  
RETURN  
END
```

FUNCTION HVAVG(Y,T)
CALCULATION OF VAPOR MOLAL AVERAGE ENTHALPY.

C
C

COMMON FVVAR
COMMON A(2),B(2),PCUN(2),FRATE,KFACTR,DIST
COMMON DELTAR,TTOP,TRDT
COMMON AHU(2),BHI(2),AHV(2),BHV(2)
DIMENSION HVAR(2)
DO 1 I=1,2
1 HVAR(I)=AHV(I)+BHV(I)*(T+460.)
HVAVG=Y*(HVAR(1)-HVAR(2))+HVAR(2)
RETURN
END

```

FUNCTION WAYA(A,ANS,TOL,START,STOP,LEVEL)
C  ROUTINE TO CONVERGE ON SINGLEVALUED FUNCTION
C  A=CURRENT VALUE OF DEPENDENT VARIABLE
C  ANS=DESIED VALUE OF DEPENDENT VARIABLE
C  TOL=TOLERANCE
C  START=CURRENT VALUE OF INDEPENDENT VARIABLE
C  A BETTER VALUE RETURNED
C  STOP=LIMIT OF INDEPENDENT VARIABLE. ANSWER BETWEEN START AND
C  STOP.
C  LEVEL=1,2,OR 3 AS AN INDEX FOR MULTILEVEL USE.
C
C  WAYA WILL VARY START BETWEEN ITS INITIAL VALUE AND STOP UNTIL
C  ABS(ANS-A).LE.TOL OR 30 TRIALS TAKEN
C  ON EXIT WAYA IS:
C      -FOR NOT CONVERGED. REPEAT CALCS. WITH NEW VALUE IN START.
C      0  FOR CONVERGED IN LIMITS OR 30 TRIALS TAKEN.
C      + FOR CANNOT CONVERGE.START=INITIAL VALUE OR STOP
C  ---WHICHEVER GIVES LESSER ERROR, OR ITS INITIAL VALUE IF LEVEL
C  IS NEGATIVE.
C
-----
C
C  DIMENSION X1(4),X2(4),Y1(4),Y2(4),KOUNT(4)
C  DATA KOUNT/4*0/
C  SET X,Y,AND LEVEL
C  X=START
C  Y=ANS-A
C  I=IABS(LEVEL)
C  WAYA=1.0
C  SEE IF CONVERGED
C  IF(ABS(Y).LE.TOL) GO TO 70
C  NOT CONVERGED.SEE WHICH CALL.
C  IF(KOUNT(I)) 80,30,10
C  SECOND OR HIGHER CALL. SEE IF Y AND Y1(I) BRACKET ANSWER.
10 IF(Y*Y1(I).LT.0.0) GO TO 20
C  NO Y-Y1 BRACKET. SEE IF SECOND OR HIGHER CALL
C  IF(KOUNT(I).GT.1) GO TO 30
C  NO BRACKET AT ALL. RE-UP AT START IF THAT LIMIT IS CLOSER OR IF
C  LEVEL IS MINUS.
C  IF(ABS(Y).LE.ABS(Y1(I)).AND.LEVEL.GT.0) GO TO 80
C  X=X1(I)
C  KOUNT(I)=-1.
C  GO TO 60
C  Y-Y1 BRACKET. STORE X&Y IN X2(I) AND Y2(I).
20 X2(I)=X
C  Y2(I)=Y
C  GO TO 40
C  FIRST CALL OR CONVERGING Y-Y2 BRACKET CALL. STORE X&Y IN X1 & Y1.
30 X1(I)=X
C  Y1(I)=Y
C  X=STOP
C  IF(KOUNT(I).EQ.0) GO TO 50
C  INTERPOLATE NEW X AND CONTINUE OR QUIT DEPENDING ON KOUNT(I).
40 X=(X1(I)*(3.*Y2(I)-Y1(I))+X2(I)*(Y2(I)-3.*Y1(I)))/(4.*(Y2(I)-
%Y1(I)))
C  IF(KOUNT(I).GE.30) GO TO 70
50 KOUNT(I)=KOUNT(I)+1
60 WAYA=-1.0
C  GO TO 90
C  CONVERGED OR TOO MANY TRIALS
70 WAYA=0.0

```

```
80 KOUNT(L)=0
C   SET NEW VALUE OF INDEPENDENT VARIABLE.
90 START=X
   RETURN
   END
```

BIBLIOGRAPHY

1. Din, F. and Cockett, A.H., Low-Temperature Techniques, New York: Interscience Publishers, Inc., 1960.
2. Maxwell, J.B., Data Book on Hydrocarbons, First Edition, Princeton, N.J.: D. Van Nostrand Company, Inc., 1958.
3. Perry, J.H., Chemical Engineers' Handbook, Fourth Edition, New York: McGraw-Hill Book Company, 1963.
4. Peters, M.S. and Timmerhaus, K.D., Plant Design and Economics for Chemical Engineers, Second Edition, New York: McGraw-Hill Book Company, 1968.
5. Ruhemann, M., The Separation of Gases, Second Edition, London: Oxford University Press, 1949.
6. Simpson, C.H., Chemicals from the Atmosphere, New York: Doubleday and Company, Inc., 1969.
7. Smith, B.D., Design of Equilibrium Stage Processes, New York: McGraw-Hill Book Company, 1963.
8. Sorel, M., La Rectification de l'Alcohol, Paris, 1893.
9. Van Winkle, M., Distillation, New York: McGraw-Hill Book Company, 1967.