



# Effect of cenosphere and specimen crack lengths on the fracture toughness of Al6061-SiC composites

E. Ashoka

*Department of Mechanical Engineering, Bapuji Institute of Engineering and Technology, Davangere, India.*  
ashokamech06@gmail.com, <http://orcid.org/0000-0002-3062-5883>

C. M. Sharanaprabhu

*PES Institute of Technology and Management, Shivamogga, India.*  
cmsharanaprabhu@gmail.com, <https://orcid.org/0000-0002-4257-039X>

G Kodancha Krishnaraja

*Department of Mechanical Engineering, KLE Technological University, Hubli, India.*  
krishnaraja@kletech.ac.in, <https://orcid.org/0000-0002-9402-0189>

**ABSTRACT.** Main aim of this work is to investigate the influences of addition of cenosphere and specimen crack length on the fracture toughness of Al6061-SiC composites. The experimental analysis was carried out for 3, 6 and 9 wt% proportions of cenosphere with 3 wt% of SiC as reinforcements in the aluminum 6061 matrix for various crack lengths. The fracture toughness of Al6061-SiC-Cenosphere hybrid composites was estimated using compact tension (CT) specimen for the said compositions. The CT specimens were prepared, according ASTM E399 standard, for different crack length to width ( $a/W=0.3-0.6$ ) ratios. From the experimental outcomes, it is identified that the fracture toughness of the hybrid composite increases upto the 6wt% of cenosphere and further increment in the cenosphere causes the decrement in the values. It is also found that the load bearing capacity and fracture toughness of the hybrid composite decreases with increment in  $a/W$  ratios of the CT specimen.

**KEYWORDS.** Cenosphere, fracture toughness, CT specimens,  $a/W$  ratios, hybrid composites



**Citation:** Ashoka E., Sharanaprabhu, C. M., Krishnaraja, G. K., Effect of cenosphere and specimen crack lengths on the fracture toughness of Al6061-SiC composites, *Frattura ed Integrità Strutturale*, 61 (2022) 473-486.

**Received:** 22.05.2022  
**Accepted:** 13.06.2022  
**Online first:** 17.06.2022  
**Published:** 01.07.2022

**Copyright:** © 2022 This is an open access article under the terms of the CC-BY 4.0, which permits unrestricted use, distribution, and reproduction in any medium, provided the original author and source are credited.

## INTRODUCTION

The properties of monolithic alloys used for commercial applications can be improved by metal matrix composites which are nearly isotropic in nature [1]. Investigators [2-4] proved that the Al alloy matrices along with ceramics as reinforcement exhibits high strength and low coefficient of thermal expansion as compared to various alloy



matrices. Aluminium 6061 alloy is widely utilized as matrix material for MMCs reinforced with different fibres, particles and whiskers due to its fluidity, castability and good bonding between them [5-7]. Accordingly, there requires an information about casting process of Aluminium 6061 alloy MMCs by several methods which is related to capacity of production based on the marketable applications. Different casting process techniques have been utilized for Aluminium 6061 alloy MMCs such as: powder metallurgy [8], mechanical alloying [9], stir casting [10], squeeze casting [11], comocasting [12] and spray deposition [13]. The various casting process techniques will changes the mechanical characterization of Aluminium 6061 alloy MMCs [14]. Investigators [15-17] analyzed and predicted that the liquid metallurgy method of casting process is applicable for mass production, simplicity and easy adoption. Stir casting technique is widely used liquid casting technique due to its low cost and ease way of processing, and even at higher weight percentages, this will also give the uniform distribution of the particle in matrix materials [18].

Furthermore, during casting of Aluminum 6061 alloy MMCs, the reinforced particulate particles must be easily available and economic for processing technique. SiC, TiC, Al<sub>2</sub>O<sub>3</sub>, B<sub>4</sub>C, and graphite were most used reinforcements in aluminum matrix [19]. Lei and Ledbetter [20] showed that the variation of micro structural reinforcement parameters such as: shape, size, volume fraction will affect the properties of metal matrix composites under elastic conditions. Researchers [21-23] conducted experiments on effects of SiC reinforcements on Al matrix composites and recommended that the addition of SiC particulate particles to Al matrix up to certain limit will improve some mechanical properties such as: yield strength, modulus of elasticity, hardness etc. The major limitation of Al 6061 alloy MMCs is the manufacturing cost; this can be overcome with the usage of lower cost of reinforcement particulate particles such as flyash and natural minerals. In thermal power plants the waste byproduct of coal is fly ash or cenosphere which is available in abundant [24]. Dung [25], Rao [26] carried out investigation on fly ash particles reinforcement with Al alloy matrix using stir casting route. They [25, 26] suggested that the fly ash form good bonding with Al alloy matrices, and it will enhance the mechanical properties based on the requirement for marketing applications. Also, addition of fly ash reinforcement with Al alloy matrix will increase the wear resistance property there by increasing the service life of the component [27].

In most of the cases the addition of cenosphere reduces the strength of the aluminum matrix composite [28]. This can be overcome by using hybrid metal matrix composites (HMMS) which enhance its mechanical properties. Moreover, the performance for hybrid materials can be improved by selecting appropriate reinforcements which are easily wettability with matrix [29]. Moorthy et.al.[30] studied the mechanical properties for graphite and fly ash particles reinforced with Al6061 by keeping 3wt% of graphite and varying fly ash content form 3wt% to 9wt% with an increment of 3wt%. Viney et. al. [31] carried out work on two hybrid composites viz., Al6061-4%Mg/flyash and Al6061-4%Graphite/flyash and concluded that addition of flyash increases the tensile strength of the hybrid composites. Mahendra [32] showed that the enhancement of SiC and fly ash reinforced with Al metal matrix particulates will improve the strength of the material as compare to conventional metal. It is seen from the researchers [33-35] that the analyses for fly ash hybrid composites were carried out by varying 3-9 wt% of flyash and fixing 3 wt% of Graphite, Mg and SiC. In our earlier investigation [36] evaluation of tensile properties was carried out for Al6061-SiC/Cenosphere hybrid MMCs. The results [36] clearly demonstrates that the nature of true stress-strain for various composition of Al6061-SiC-Cenosphere hybrid MMCs will almost matches with the pure Al6061 alloy and bearing more strength. Hence, Al6061-SiC/Cenosphere hybrid MMCs can be used for pressure vessel applications. For pressure vessel analysis fracture toughness is the parameter to estimate the strength of the material. The fracture toughness of the metallic material can be estimated by single edge notch bend (SENB) and compact tension (CT) specimens according to American society for testing and materials (ASTM) standards. Researchers [37-42] analyzed that the fracture toughness estimated by ASTM standard specimens depends on the thickness and crack length of the specimen. Hence, in this paper an effort is made to analyze the influence of addition of cenosphere and specimen crack lengths on the fracture toughness for Al-SiC composites.

## MATERIALS AND PREPARATION

From the literature, it is seen that the adding of the high weight fraction of SiC in the aluminum leads to no significant increments in the hardness. Further the addition of SiC as reinforcement in the aluminum matrix increases the weight of the composites since its density is 3.22 g/cc which is higher than the Al6061. Thus, the low weight fraction will give the better strength and hardness, reduced weight and avoids the clustering of the reinforcement in the composite. Thus, in the present work, the composition of the SiC is considered as 3wt%.

Also, addition of cenosphere in the aluminum matrix reduces the weight of the composites [24]. Thus, the composite can be utilized in the automobile industries, where the requirement is the decreased weight [25]. However, the increase of cenosphere in aluminum matrix increases the strength and hardness of composites up to 7wt%. Further increment causes



the decrement in the properties has been observed. Thus, in this work the 3, 6 and 9 wt% of cenosphere is considered as second reinforcement. Also, literature [43] recommends having cenosphere as reinforcements due to the high content of the oxides. Hence, addition of this into the aluminum enhances the properties of the hybrid composite. Fig. 1 (a & c) shows the EDX analysis of the cenosphere and the silicon carbide. Fig. 1 (b & d) shows the particle size of the cenosphere and the silicon carbide. The average particle size of cenosphere and silicon carbide is 15 $\mu\text{m}$  and 30 $\mu\text{m}$  respectively.

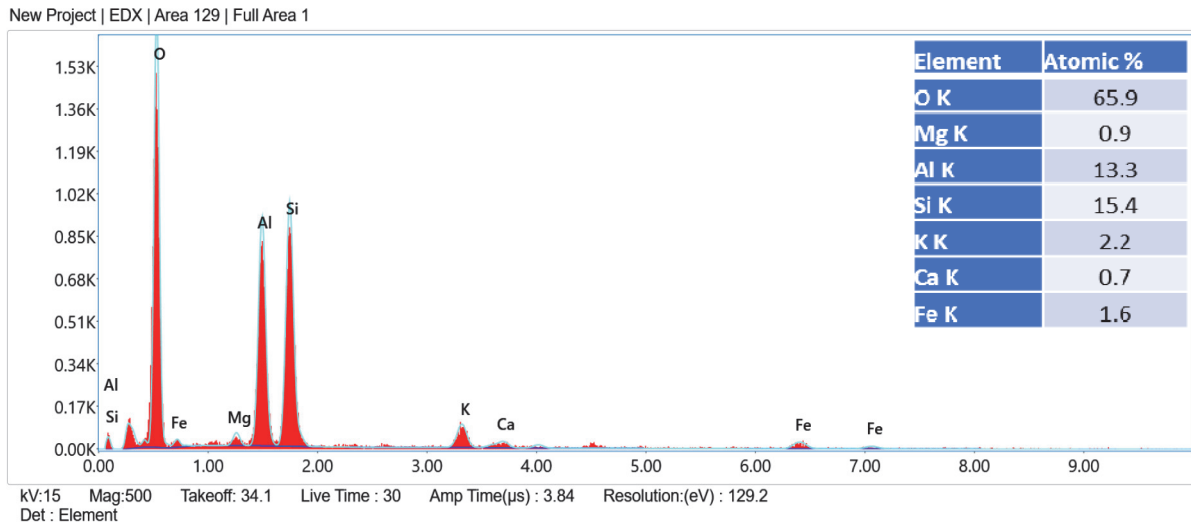

Figure 1(a): Composition of Cenosphere

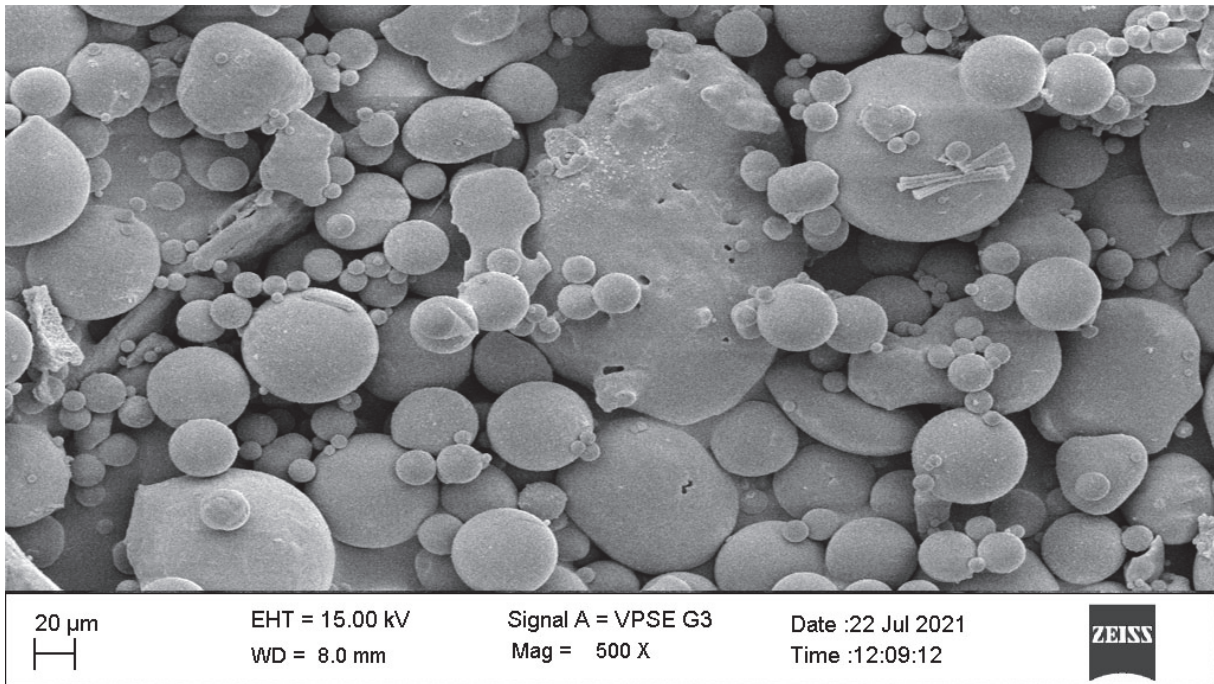

Figure 1(b): Particle size of Cenosphere.

The composite is prepared using stir casting route for 3 wt% of SiC and 3, 6 and 9 wt% of cenosphere. The Al6061 is super-heated to the temperature 720 $^{\circ}\text{C}$  in a graphite crucible. While stirring at 500rpm the required quantity of SiC and cenosphere particles were added to the liquid aluminum. The degasifier and flux has been introduced to remove the gases from the molten metal. The liquid melt is poured to the graphite mold and allowed to solidify. The bars taken from the mold were machined to prepare the CT specimens.

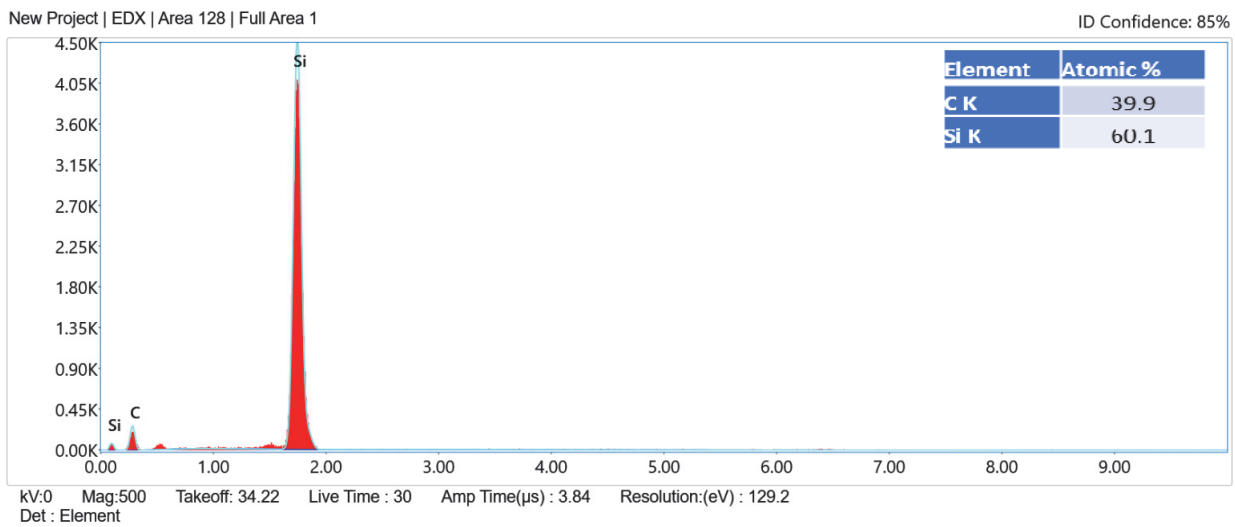

Figure 1(c): Composition of SiC

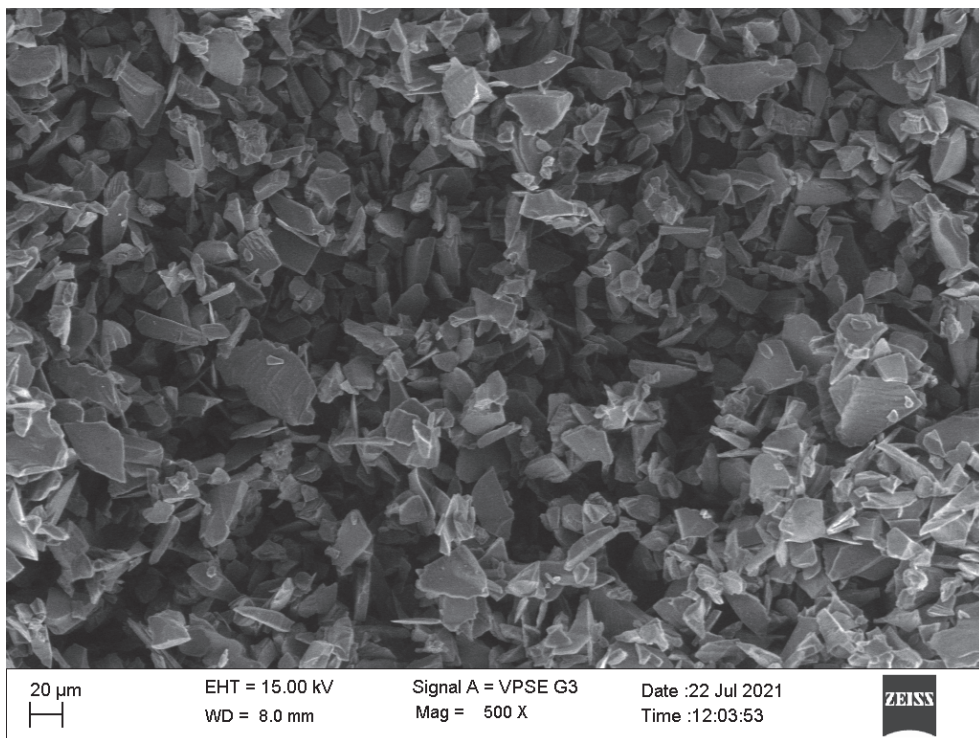

Figure 1(d): Particle size of SiC

Fig. 2 shows the energy dispersive x-ray (EDX) analysis of the Al-SiC/cenosphere composites prepared for the various compositions. Through this method the confirmation of the presence of reinforcing elements in the prepared composites can be quantified. Fig 2(a-c) shows the EDX analysis of Al6061-3wt%SiC+3,6,9 wt% cenosphere showing the presence of carbide, oxide, magnesium, silicon and iron. By the increase of the weight percentage cenosphere, the increases in the carbide, oxides, iron, which confirms the presence of cenosphere. The other elements Mg, Si confirms the presence aluminum 6061.

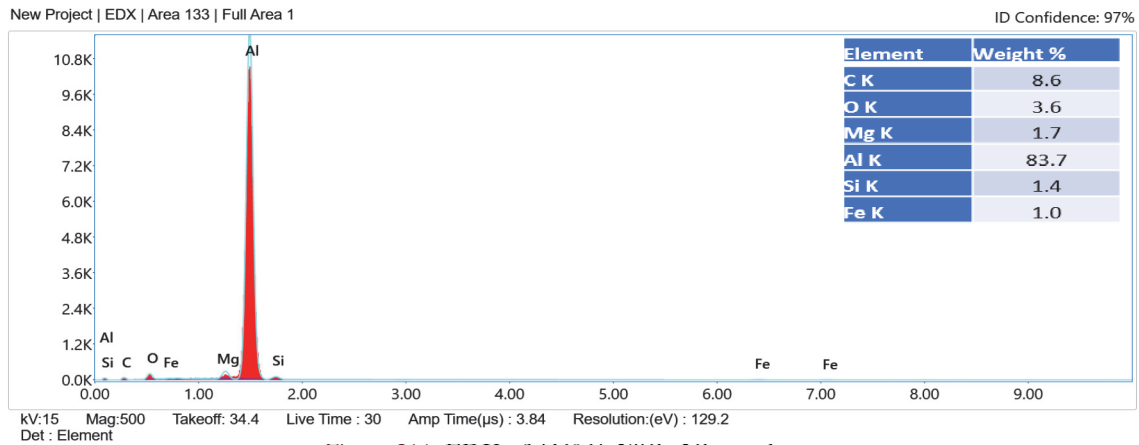

Figure 2(a): EDX of Al6061-3SiC+3Cenosphere.

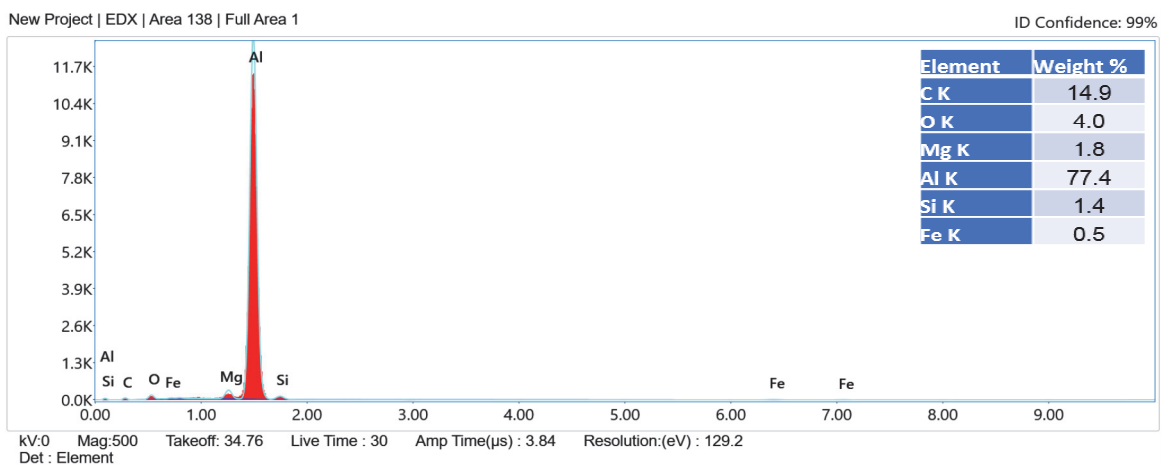

Figure 2(b): EDX of Al6061-3SiC+6Cenosphere.

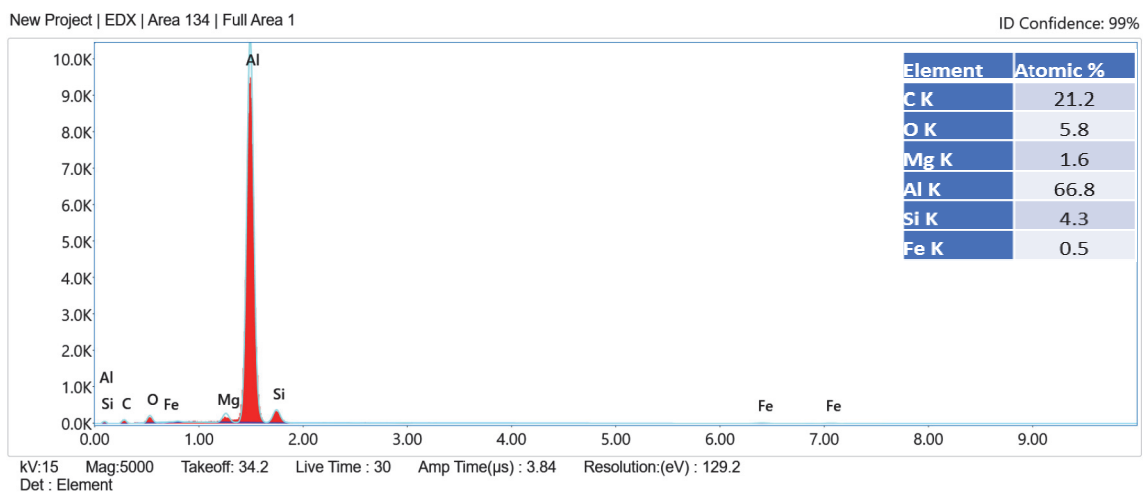

Figure 2(c): EDX of Al6061-3SiC+9Cenosphere.

Energy dispersive spectroscopy (EDS) micrographs, Fig3(a-i), shows the mapping of composites and their reinforcements. Fig. 3 shows the mapping of elements in the prepared Al-SiC/cenosphere composites. The notations used are Al for aluminum, Si for silicon carbide and O for cenosphere as it contains most of oxides.



The EDS micrograph shows the three different areas in the composites viz., Fig 3(a,d,g) shows the mapping distribution of the reinforcements in the mentioned hybrid composites, Fig 3(b,e,h) shows SiC particle mapping and Fig 3(c,d,i) shows cenosphere particle mapping. From Fig. 3 it is confirmed that the distribution of the SiC and cenosphere particles is uniform in the Aluminum matrix. Fig 3(c,d,i) it can be observed the increased cenosphere particles in the matrix.

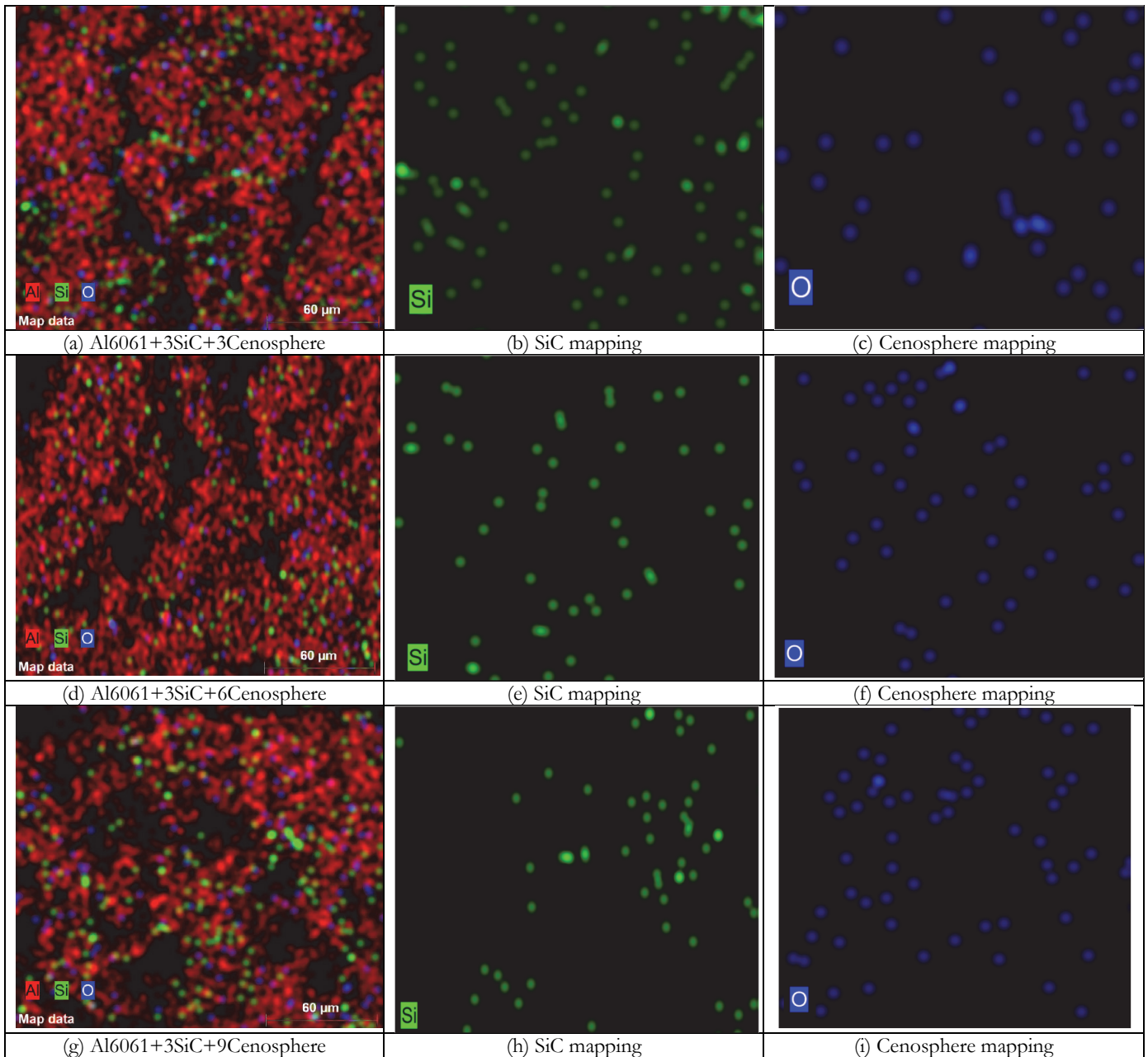

Figure 3: EDS Images showing the mapping of composites and reinforcements.

## EXPERIMENTATION

The CT specimens were prepared to the geometry as shown in the Fig.4. The notch of size 3mm x 7mm, 3mm x 9.50mm, 3mm x 12mm and 3mm x 14.5mm is prepared using wire cut EDM, a fatigue crack of length 0.62mm, 0.66mm, 0.7mm and 0.74mm for the a/W ratios 0.3, 0.4, 0.5 and 0.6 respectively.

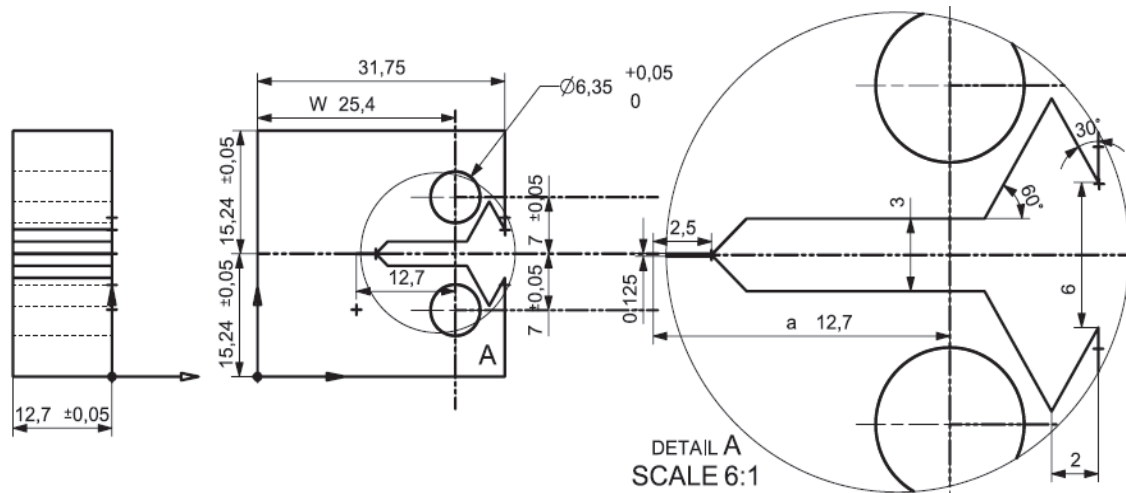

Figure 4(a): Geometry of CT specimen.

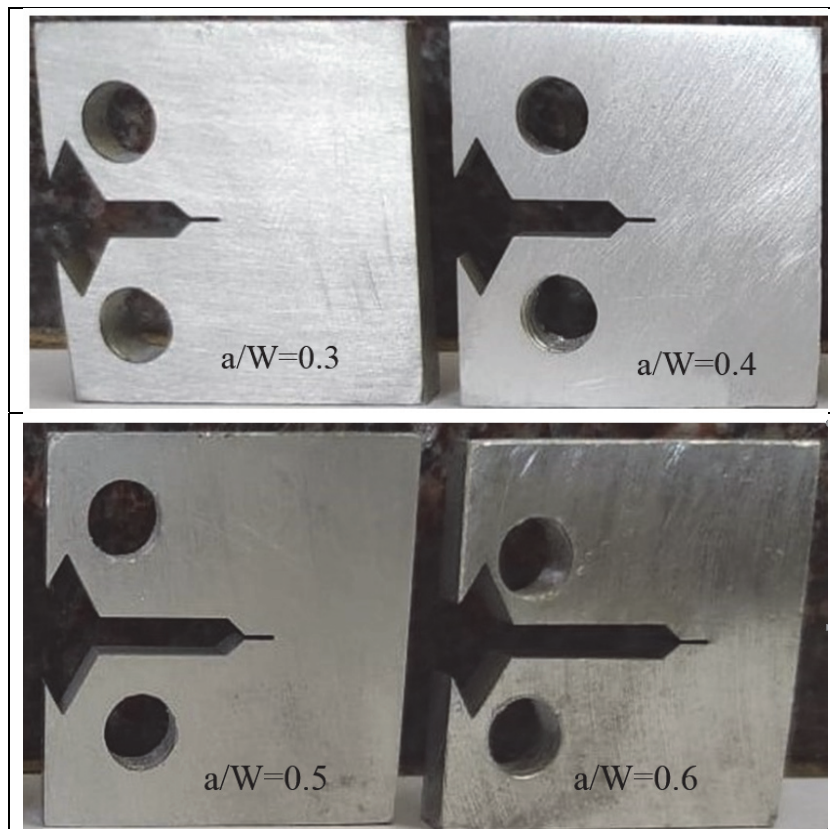

Figure 4(b): CT specimen specifications.

The CT specimens of different  $a/W$  ratios with constant thickness of  $B=10\text{mm}$  are subjected to fracture toughness testing as per the standard testing procedure prescribed by the ASTM E399. While testing CT specimens, the displacement rate maintained is  $1\text{mm}/\text{min}$ , load ratio considered is 0.1 and cyclic load applied at  $5\text{Hz}$  frequency. During the experimentation, the critical load  $P_Q$  and the crack mouth opening displacement (CMOD) is recorded for each CT specimen. The provisional fracture toughness ( $K_Q$ ) can be determined for the value  $P_Q$  using the empirical equation available [37-38]. If the values of the geometry of CT specimens, such as crack length ( $a$ ), width ( $W$ ) and thickness ( $B$ ) of the specimen, satisfies the conditions [44] of the plain strain fracture toughness, the calculated  $K_Q$  can be considered as fracture toughness ( $K_{Ic}$ ).



## RESULTS AND DISCUSSIONS

The CT specimens of different  $a/W$  ratios and compositions of Al6061-SiC/Cenosphere composites were subjected to tensile testing to evaluate the critical load ( $P_Q$ ) by plotting load vs. CMOD. For each experimentation, three identical CT specimens were utilized, and the average values were taken to plot load vs. CMOD. Fig. 5 to 7 shows the variation of load vs. CMOD for all the compositions of said composites and  $a/W$  ratio = 0.3 to 0.6. From the Figs.5 to 7 it is observed that the load vs CMOD curves follows the type III curve [44], that shows the maximum load itself is the critical load [45]. Hence the  $P_Q$  is considered to evaluate the fracture toughness ( $K_{Ic}$ ) of the composites.

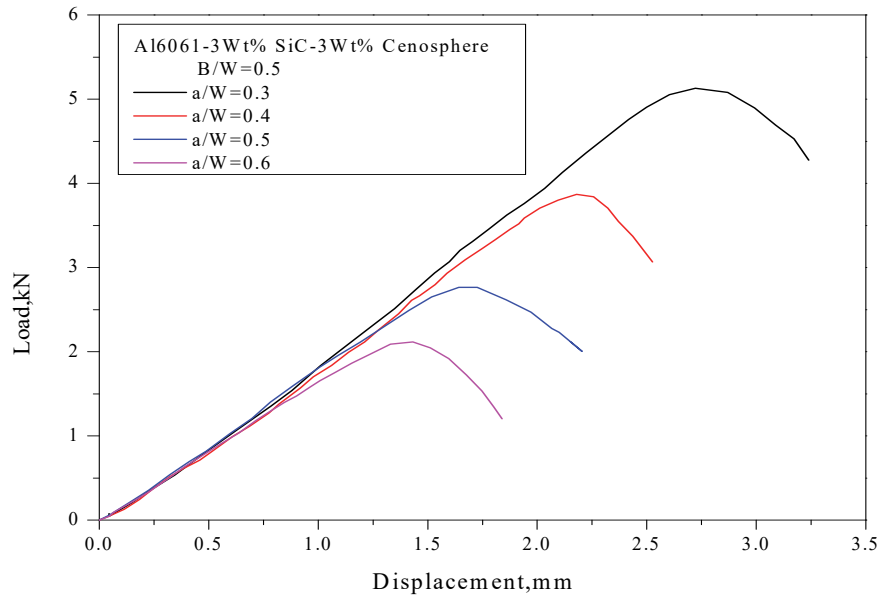

Figure 5: Load vs. CMOD curves for Al6061+3wt% SiC+ 3wt% Cenosphere.

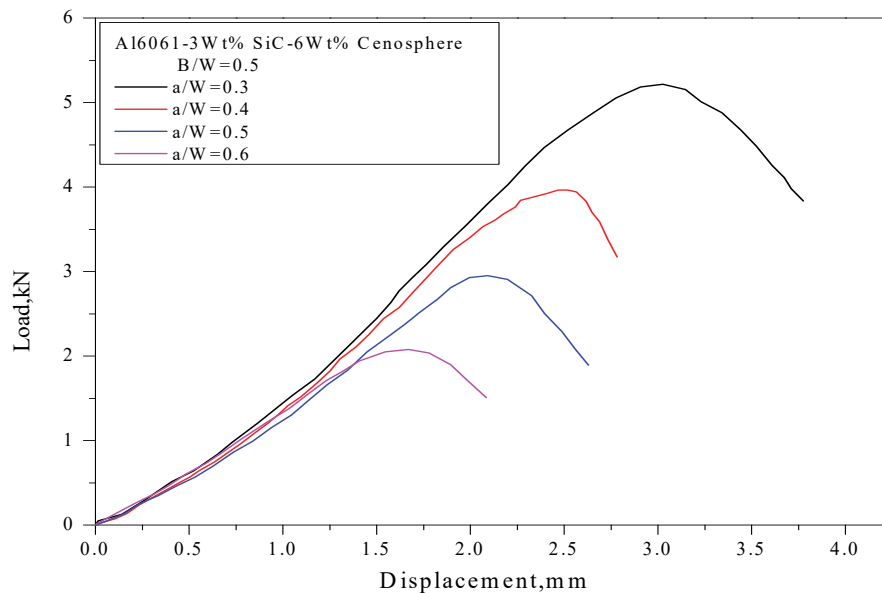

Figure 6: Load vs. CMOD curves for Al6061+3wt% SiC+ 6wt% Cenosphere.



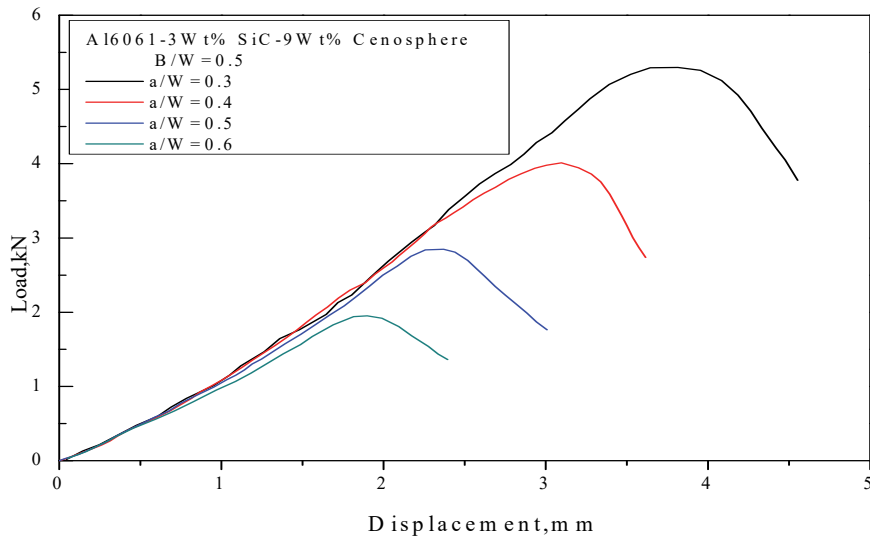

Figure 7: Load vs. CMOD curves for Al6061+3wt% SiC+ 9wt% Cenosphere.

Figs. 5 to 7 reveals that the load carrying capacity of the said hybrid composite decreases with increase in  $a/W$  ratios for all the compositions. For the said Al6061-SiC/Cenosphere composites and  $a/W$  ratios, the provisional fracture toughness  $K_Q$  has been determined using the empirical equations [37-40] by considering the values of critical load ( $P_Q$ ) and dimensions of CT specimens.

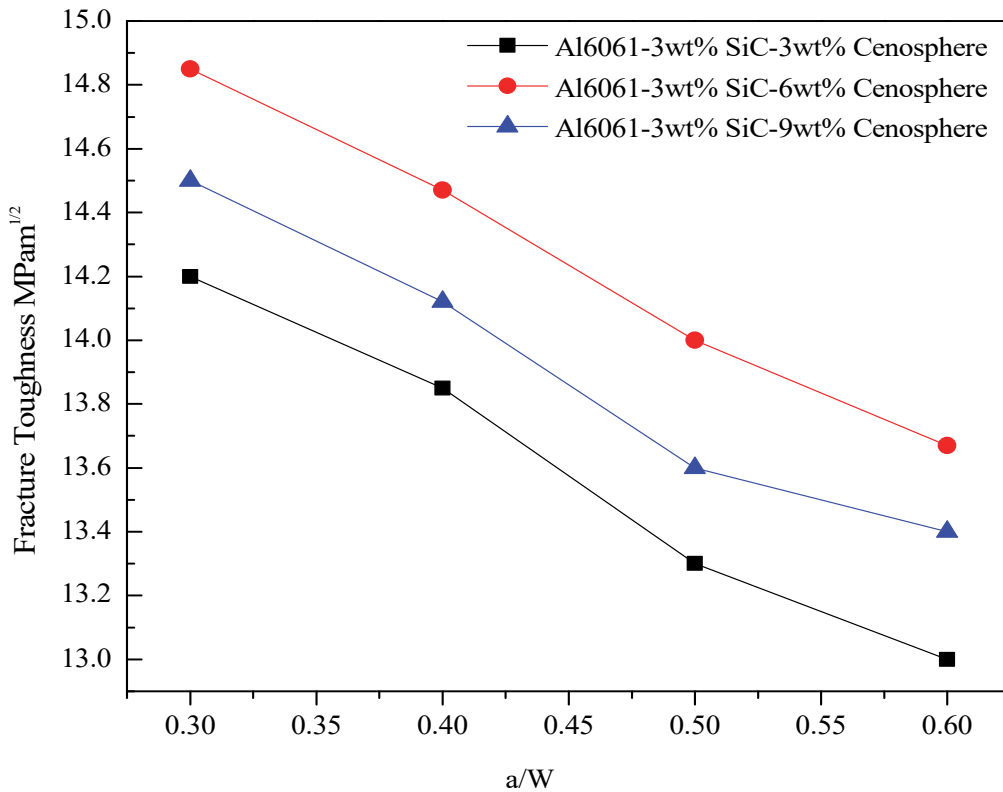
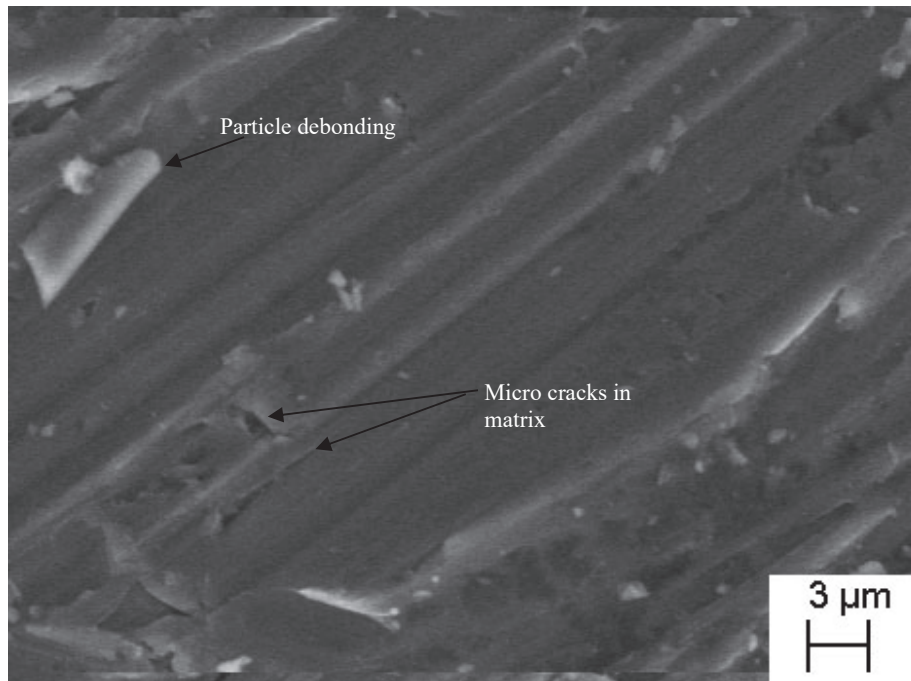

Figure 8: Variation of fracture toughness vs.  $a/W$  ratio .

Fig.8 shows the fracture toughness of Al6061-SiC/Cenosphere hybrid composite with increasing  $a/W$  ratio. From the Fig.8 it is observed that increment in the crack length to width ratio reduces the fracture toughness of the Al6061-

SiC/Cenosphere composites. It is noticeable that as crack length increases in the material, which decreases the load carrying capacity which in turn causes reduction in fracture toughness. It is also observed that, at a/W ratio 0.3 to 0.6, the composite with 6 wt% of cenosphere shows highest fracture toughness which is around 6% higher than the 3wt% of cenosphere. It is clear that as the composition of the cenosphere increases fracture toughness of the composite increases up to 6wt%.



(a) Al6061+3wt%SiC+ 3wt% Cenosphere.

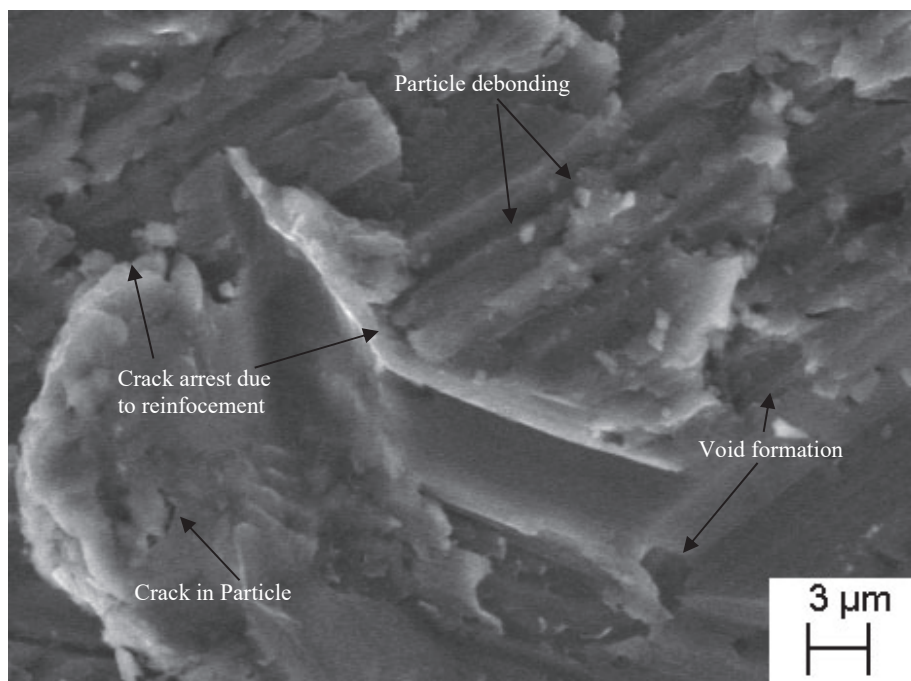

(b) Al6061+3wt%SiC+ 6wt% Cenosphere

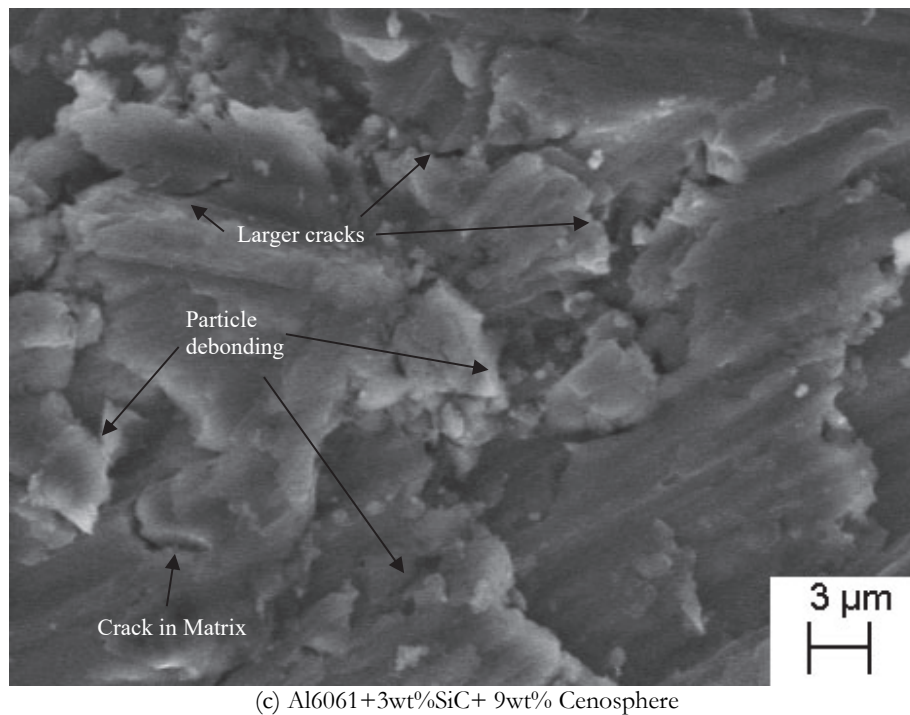

Figure 9: Fractographic images of hybrid composites

Fig 9 shows the fracture surfaces of the hybrid reinforced composites which reveals the failure mechanism between the particle (brittle fracture appeared in bright surfaces) and matrix (ductile fracture). From the graphs it observed that all the compositions failed due to the particle debonding. However, in 3wt% Cenosphere composite, micro cracks have developed in the matrix, and due to less particles crack propagation rate is more (Fig 9(a)). Thus, decreases in fracture toughness has been observed. Fig 9(a) shows the purely ductile fracture for the composite with smaller number of reinforced (6wt%) particles have small sized particles. The SiC and cenosphere particles here must act as barricade to the crack propagation in aluminum matrix (Fig 9(b)), causes the crack path deviation so the crack propagates around the reinforcing particles and also reduces the induced stresses as shown in Fig 9(c). This barricade due to SiC and cenosphere particles in turn increases the limiting value for crack propagation. From the Fig 9(a-c), it can be observed that the cracks in the matrix propagates early and at particle intersection crack propagation changes its direction. Thus, the crack propagation rate increases in turn increases the fracture toughness of the composite. However, Fig 9(c) shows the several cracks (marked by arrow) arises due to the increased number of large sized particles, came from 12wt% of reinforcement, since large sized particles tend to crack easily [46].

## CONCLUSIONS

The fracture toughness of the Al6061-SiC/Cenosphere has been studied for the two parameters composition and a/W ratio. The influence of addition of different percentages of cenosphere and the various a/W ratios has been investigated experimentally on the fracture toughness of the said hybrid composite.

The liquid metallurgy method used to prepare the hybrid composite leads to the uniform distribution of the reinforcements in Al6061 matrix. The EDX confirms the presence of the reinforcing elements in the Al6061-SiC/Cenosphere hybrid composite.

Results of the fracture toughness test shows, the increment in the a/W ratio reduces the fracture toughness of the said hybrid composite. Also, the increment in the cenosphere composition leads to increment in fracture toughness up to 6wt%, and further increment in the cenosphere reduces the fracture toughness. The fracture toughness of the 6wt% of cenosphere is nearly 6% higher than the 3wt% of cenosphere.



## FUNDING

This research received no specific grant from any funding agency in the public, commercial, or not-for-profit sectors.

## CONFLICT OF INTEREST

The authors declare that they have no conflict of interest.

## REFERENCES

- [1] Doddamani, S., Kaleemulla, M., Fracture toughness investigations of Al6061- Graphite particulate composite using compact specimens, *Frattura ed Integrità Strutturale*, Vol 11, 41 (2017) 484-490. DOI:10.3221/IGF-ESIS.41.61.
- [2] Onat A., Akbulut H, Yilmaz F. Production and characterization of silicon carbide particulate reinforced aluminium–copper alloy matrix composites by direct squeeze casting method. *J Alloys Compounds*, 2007; P. 436.
- [3] Md. Habibur Rahmana., H. M. Mamun Al Rashedb., Characterization of silicon carbide reinforced aluminum matrix composites 10th International Conference on Mechanical Engineering, ICME 2013 Vol 90 (2014) 103-109.
- [4] Adiamak M., Selected properties of aluminium base composites reinforced with intermetallic particles, *Journal of Achievements in Materials and Manufacturing Engineering*, Vol.14(1-2), (2006) 43–47.
- [5] Jebeen Moses.,I Dinaharan.,S. Joseph Sekhar., Characterization of Silicon carbide Particulate reinforced AA6061 aluminum alloy composites produced via stir casting, *International Conference on Advances in Manufacturing and Materials Engineering AMME 2014 Vol. 21(2)*, (2005) 143-152.
- [6] T R Mohan., C M Sharanaprabhu., Shashidhar K Kudari., Study on the Effects of Sic Particles on Tensile Properties For Al/Sic Composites. *International journal of Science, Technology & Management*, 4(1), (2015) 1477-1483.
- [7] A. Chennakesava Reddy, “Mechanical Properties And Fracture Behavior of 6061/Sicp Metal Matrix Composites Cast By Low Pressure Die Casting Process”, *Journal of Manufacturing Technology Research*, 1(3/4), (2009) 273-286.
- [8] Dhar Sudeshna, Jena Asutosh, S.C. Patnaik, S.K. Sahoo, Tripathy Omkar, A study on microstructure and mechanical properties of aluminium matrix composites with micro-sized iron fillers produced by powder metallurgy route, *2nd ICPCM Materials Today: Proceedings (2020)*. <https://doi.org/10.1016/j.matpr.2020.03.733>.
- [9] Chen Chun-Liang, Lin Chen-Han, In-situ dispersed La oxides of Al6061 composites by mechanical alloying, *Journal of Alloys and Compounds*, 775, (2019) 1156-1163. <https://doi.org/10.1016/j.jallcom.2018.10.093>
- [10] M. S. Raviraj, M Sharanaprabhu, G. C. Mohankumar, Experimental Analysis on Processing and Properties of Al-TiC Metal Matrix Composites, *Procedia Materials Science*, 5, (2014), 2032-2038. <https://doi.org/10.1016/j.mspro.2014.07.536>
- [11] M. Dhanashekar, V.S. Senthil Kumar, Squeeze Casting of Aluminium Metal Matrix Composites-An Overview, *Procedia Engineering*, 97, (2014) 412-420. <https://doi.org/10.1016/j.proeng.2014.12.265>
- [12] J David Raja Selvam, D.S Robinson Smart, I Dinaharan, Synthesis and Characterization of Al6061-Fly Ashp-SiCp Composites by Stir Casting and Compocasting Methods, *Energy Procedia*, 34, (2013) 637-646. <https://doi.org/10.1016/j.egypro.2013.06.795>
- [13] Sabard Alexandre, McNutt Philip, Begg Henry, Hussain Tanvir, Cold spray deposition of solution heat treated, artificially aged and naturally aged Al 7075 powder, *Surface and Coatings Technology*, 385, (2020) 125367, <https://doi.org/10.1016/j.surfcoat.2020.125367>
- [14] Samal Priyaranjan, R.Vundavilli Pandu, Meher Arabinda, M.Mahapatra Manas, Recent progress in aluminum metal matrix composites: A review on processing, mechanical and wear properties, *Journal of Manufacturing Processes*, 59, (2020) 131-152, <https://doi.org/10.1016/j.jmapro.2020.09.010>.
- [15] Ramanathan Arunachalam, Krishnan Pradeep Kumar, Muraliraja Rajaraman, A review on the production of metal matrix composites through stir casting – Furnace design, properties, challenges, and research opportunities, *Journal of Manufacturing Processes*, 42, (2019) 213-245. <https://doi.org/10.1016/j.jmapro.2019.04.017>



- [16] K. S. Lakshmi Narayana, M. M. Benal, H. K. Shivanand, Effect of graphite on aluminium matrix composites fabricated by stir casting route – A review, *Materials today: Proceedings*, (2020). <https://doi.org/10.1016/j.matpr.2020.11.051>
- [17] S. Sivananthan, K. Ravi, C. Samson Jerold Samuel, Effect of SiC particles reinforcement on mechanical properties of aluminium 6061 alloy processed using stir casting route *Materials Today: Proceedings*, 21(1) (2020) 968-970. <https://doi.org/10.1016/j.matpr.2019.09.068>
- [18] Maurya Nagendra Kumar, Maurya Manish, Srivastava Ashish Kumar, Dwivedi Shashi Prakash, Kumar Abdhesh, Chauhan Sandeep, Investigation of mechanical properties of Al6061/SiC composite prepared through stir casting technique *Materials Today: Proceedings* 25(4) (2020) 755-758. <https://doi.org/10.1016/j.matpr.2019.09.003>
- [19] Moorthy A. Anandha, N. Natarajan, R. Siva Kumar, M. Manoj Kumar, M. Suresh, Dry Sliding Wear and Mechanical Behaviour of Aluminium/Fly ash/Graphite Hybrid Metal Matrix Composite Using Taguchi Method, *IJMER*, 2012, 2(3) (2012)1224-1230.
- [20] Lei, M., Ledbetter, H. Elastic constants of SiCp/Al: Measurements and modeling. *Metall Mater Trans A* 25, (1994) 2832–2835. <https://doi.org/10.1007/BF02649234>
- [21] Chennakesava Reddy, Mechanical Properties And Fracture Behavior Of 6061/SiCp Metal Matrix Composites Cast By Low Pressure Die Casting Process, *Journal of Manufacturing Technology Research*, 1, (3/4), (2009) 273-286.
- [22] Singla Manoj, Dwivedi D. Deepak, Singh Lakhvir, Chawla Vikas, Development of aluminium based silicon carbide particulate metal matrix composite, *Journal of Minerals & Materials Characterization & Engineering*, Vol. 8(6) (2009) 455-467.
- [23] Gosavi V Swapnil, M.D. Jaybhaye, Microstructural studies on aluminium metal matrix composite (Al7075-SiC) fabricated through stir casting process *Materials Today: Proceedings*, (2020) <https://doi.org/10.1016/j.matpr.2020.05.094>
- [24] P K Rohatgi, A Daoud, BF Schultz, T Puri, Microstructure and mechanical behavior of die casting AZ91D-Fly ash cenosphere composites, *Composites (Part-A) Applied Science and Manufacturing*, Vol. 40(6-7), (2009) 883-896.
- [25] D Dung, Gupta N, A Daoud, & P K Rohatgi, High strain rate compressive characterization of aluminum alloy/fly ash cenosphere composites, *JOM*, 63(2), (2011) 53–56.
- [26] J Babu Rao, D Venkata Rao and N R M R Bhargava, Development of light weight ALFA composites, *International Journal of Engineering, Science and Technology*, Vol. 2(11), (2010) 50-59.
- [27] J Babu Rao, D Venkata Rao, K N Siva Prasad, N R M R. Bhargava, Dry sliding wear behaviour of fly ash particles reinforced AA 2024 composites. *Mater Sci-Pol* 30, (2012) 204–211. <https://doi.org/10.2478/s13536-012-0026-z>
- [28] O E Gikunoo & I N A Oguocha, Effect of fly ash particles on the mechanical properties of aluminium casting alloy A535, *Materials Science and Technology*, 21:2, (2005) 143-152, DOI: 10.1179/174328405X18601
- [29] M Y Zhou, L B Ren, L L Fan, Y W X Zhang, T H Lu, G F Quan, M Gupta, Progress in research on hybrid metal matrix composites, *Journal of Alloys and Compounds*, 838, (2020) 155274. <https://doi.org/10.1016/j.jallcom.2020.155274>
- [30] N Natarajan, A Anandha Moorthy, R Sivakumar, M Manojkumar, M Suresh, Dry Sliding Wear and Mechanical Behavior of Aluminium/Fly ash/Graphite Hybrid Metal Matrix Composite Using Taguchi Method, *International Journal of Modern Engineering Research*, 2(3), (2012) 1224-1230.
- [31] Kumar Viney, Gupta Rahul Dev, N K Batra, Comparison of Mechanical Properties and Effect of Sliding Velocity on Wear Properties of Al 6061, Mg 4%, Fly Ash and Al 6061, Mg 4%, Graphite 4%, Fly Ash Hybrid Metal Matrix Composite, *Procedia Materials Science*, 6, (2014) 1365-1375. <https://doi.org/10.1016/j.mspro.2014.07.116>
- [32] Haider, U., Bittnar, Z., Kopecky, L., Bittnar, P., Němeček, J., Ali, A., Pokorný, J., Mechanical behaviour and durability of high volume fly ash cementitious composites, *Frattura ed Integrità Strutturale*, 38 (2016) 289-302.
- [33] S Venkat Prasad, R Subramanian, Tribological properties of AlSi10Mg/fly ash/graphite hybrid metal matrix composites, *Industrial Lubrication & Tribology*, Vol. 65(6), (2013) 399-408.
- [34] N Balaje Krishna, Unnikrishnan Parvathy, S Ilangovan, Synthesis and Characterization of Zircon/Graphite and Flyash/Graphite Reinforced Aluminium7075 Alloy: A Comparative Study, *Journal of Materials and Environmental Sciences*, 9, (1), (2018) 26-31.
- [35] Wasekar, M. K., Khond, M. P., Analysis of the influence of reinforcements on the microstructure and mechanical characterization of the Al-Flyash composites, *Frattura ed Integrità Strutturale*, 56 (2021) 217-228.
- [36] E Ashoka, C M Sharanaprabhu, Kodancha G Krishnaraja, S K Kudari, Experimental processing and the effects of cenosphere on some mechanical properties of Al6061-SiC composites, *AIP Conference Proceedings*, 1943(1), (2018) 020103. <https://doi.org/10.1063/1.5029679>



- [37] M S Raviraj, C M Sharanaprabhu, G C Mohankumar, Experimental investigation of effect of specimen thickness on fracture toughness of Al-TiC composites, *Frattura ed Integrità Strutturale*, 37 (2016) 360-368.
- [38] Doddamani Saleemsab, K Mohammed Kaleemulla, Effect of graphite on fracture toughness of 6061Al-Graphite, *Strength, Fracture and Complexity*, Vol. 11 (4) (2018) 295-308. DOI: 10.3233/SFC-180230.
- [39] A B Pandey, Effects of Thickness and Pre cracking on the Fracture Toughness of Particle-Reinforced Al-Alloy Composites, *Metallurgical and Materials Transactions A*, 29 (4), (1998) 1237-1243.
- [40] Yasmin Begum, K N Bharath, Doddamani Saleemsab, A M Rajesh, K Mohamed Kaleemulla, Optimization of process parameters of fracture toughness using simulation technique considering aluminum-graphite composites, *Transactions of the Indian Institute of Metals, Springer*, Vol. 73(12) (2020), 3095 – 3103. DOI: 10.1007/s12666-020-02113-5.
- [41] Dhummansure Vishalkumar, Ambad Amol Kalyanrao, Doddamani Saleemsab, Optimization of process parameters for fracture toughness of Al6061-graphite composites, *Structural Integrity and Life*, Vol. 20(1) (2020) 51–55.
- [42] M S Raviraj, C M Sharanaprabhu, G C Mohankumar, Experimental and 3D FE Evaluation of Crack Initiation Energy J 1C in Al6061-TiC Composites. *Strength, Fracture and Complexity*, vol. 11(1), (2018) 63-72. DOI: 10.3233/SFC-180213
- [43] Sudarshan, M K Surappa, Synthesis of fly ash particle reinforced A356 Al composites and their characterization, *Materials Science and Engineering A* 480 (2008) 117–124. doi:10.1016/j.msea.2007.06.068.
- [44] Doddamani Saleemsab, K Mohammed Kaleemulla, J O Kiran, Fracture toughness testing of 6061Al-graphite composites using SENB specimens, *Journal of The Institute of Engineers (India)-series D, Springer*, 100(2), (2019) 195-201. DOI: 10.1007/s40033-019-00188-z.
- [45] Doddamani, S., Kaleemulla, M., Experimental investigation on fracture toughness of Al6061-graphite by using Circumferential Notched Tensile Specimens, *Frattura ed Integrità Strutturale*, 39 (2017) 274-281. DOI: 10.3221/IGF-ESIS.39.25.
- [46] Chaubey Anil K, Gokuldoss Prashanth Konda, Wang Zhi, Scudino Sergio, Mukhopadhyay Nilay K. and Eckert Jürgen, Effect of Particle Size on Microstructure and Mechanical Properties of Al-Based Composite Reinforced with 10 Vol.% Mechanically Alloyed Mg-7.4%Al Particles, *Technologies*, 4(37) (2016) 1-8; doi:10.3390/technologies4040037