

High-Temperature Electrochemistry of Calcium

Yuriy Zaikov^{ab}, Victor Batukhtin^a, Nikolay Shurov^a, and Andrey Suzdaltsev^{ab*}

Received: 12 July 2022
Accepted: 03 September 2022

DOI: 10.15726/elmattech.2022.1.007

Electrolytically produced calcium is one of the most demanded materials in obtaining pure materials. At the same time, the existing technologies and devices for the electrolytic production of calcium were developed in the last century, and at present there are practically no works aimed at optimizing them. However, increasing the capacity and efficiency of existing devices for the production of calcium is in demand. To analyze possible ways to improve calcium production, a comprehensive understanding of the processes occurring at the electrodes and in the electrolyte during electrolytic production of calcium is required.

This review briefly outlines the main points concerning the electrolytic production of calcium: from a brief history of the development of methods for the electrolytic production of calcium and established ideas about its physicochemical processes to information about new developments using the electrolysis of CaCl₂-based melts. Review content: brief history of process development; base electrolyte for calcium production, including preparation of CaCl₂ and influence of additions on its physicochemical properties; data on calcium solubility in CaCl₂; information about alternative electrolytes for calcium production; short description of electrode processes in the CaCl₂-based melts; proposed technologies and devices for the electrolytic production of calcium.

keywords: calcium, calcium chloride, ion-electron liquid, Cu–Ca alloy, molten salt, calcium solubility, electrode processes, inert anode, electrolysis, current efficiency, electrolyzer

© 2022, the Authors. This article is published in open access under the terms and conditions of the Creative Commons Attribution (CC BY) license <http://creativecommons.org/licenses/by/4.0/>.

1. Introduction

Due to its physicochemical properties, abundance in the earth's crust, and low toxicity, calcium is one of the most demanded elements for the production and processing of materials in various industries [1–8]. The main areas of stable consumption of calcium and its alloys are calcium-thermal production of metals (Ni, Cu, Fe, Cr, Th, U, REM, etc.) [9–11] and steel deoxidation [12–14]. Along with this,

the possibility of using calcium in calcium-ion, calcium-air and calcium-sulphur batteries, which can replace more expensive lithium-ion batteries [15–20], as well as in hydrogen storage [21], is being actively studied. All this indicates the relevance of research aimed at optimizing existing technologies and increasing the capacity of reactors for calcium production.

At present, the following methods of calcium production are implemented in industry: electrolysis of CaCl₂ halide melt with additions of KCl, NaCl, or CaF₂ at a temperature of 750–850°C [22–24], as well as aluminothermic reduction of CaO at a temperature of 1170–1250°C [25–

a: Institute of High-Temperature Electrochemistry UB RAS, Ekaterinburg 620137, Russia

b: Institute of Chemical Engineering, Ural Federal University, Ekaterinburg 620009, Russia

* Corresponding author: suzdaltsev_av@ihte.uran.ru

28]. During the electrolysis of the CaCl₂ melt, calcium is released on the cathode, the purity of which after separation from the cathode and electrolyte is 99.9 wt% and higher. Despite the simplicity of execution and relatively low temperature, electrolytic methods imply a thorough purification of hygroscopic CaCl₂ from crystallization moisture and CaO. The chlorine released at the carbon anode is used for chlorination of Ca(OH)₂ and is captured by aqueous solutions. Aluminothermic reduction also requires preliminary purification of CaO from CaCO₃, while the main disadvantages of the method are the relatively high process temperature and the low purity of the resulting calcium (98.0–99.5 wt%, mainly due to the presence of aluminum and inclusions of calcium aluminates). As a result, aluminothermically obtained calcium cannot be used, in particular, for the production of highly pure metals.

Today, the main producers of calcium are the enterprises of China, USA, Russia, India, Canada, France, while the technologies and devices developed in the last century are used in the electrolytic production. Scientific and practical research aimed at optimizing existing and developing new more efficient technologies for the electrolytic production of calcium is extremely limited. First of all, this is due to increased requirements for the purity of calcium chloride as well as the culture of research.

This review provides basic ideas about the high-temperature electrochemistry of calcium, including:

- a brief history of the development of a method for the electrolytic production of calcium;
- data on the nature and properties of melts based on CaCl₂;
- patterns of electrode processes in melts based on CaCl₂ in the production of calcium, Cu-Ca alloy, as well as in the production of other metals and alloys;
- brief data on the development of new technologies and devices for the electrolytic production of calcium.

2. Brief history of process development

For the first time, the electrolytic production of metallic calcium by electrolysis of its alkali on a mercury cathode was mentioned by Davy in 1808 [29]. Later, in 1855, calcium was obtained by Bunsen and Mathissen by electrolysis of molten CaCl₂. At the same time, the authors noted the "sputtering" of calcium in CaCl₂,

leading to a decrease in the cathodic current efficiency (to zero for barium). To reduce this negative effect, the authors used high cathodic current densities and for the first time obtained calcium of technical purity [3].

In 1893, Borches and Stochem used a cooled contact cathode and obtained calcium in the form of a sponge. In 1902, Ruff and Plato were the first to use for electrolysis a CaCl₂-CaF₂ eutectic mixture with a lower melting point and lower calcium solubility. This electrolyte was later used in the "touch cathode" electrolysis technology [3].

From 1886 to 1903 in Germany, Zutter and Redlich developed a method and an electrolyzer for calcium production using a cooled touch iron cathode that slowly rose from a salt melt [30]. In 1904, a plant in Bitterfeld (Germany) started operating using this technology, which worked until 1945.

This technology has now been superseded by the more productive and economical liquid copper cathode electrolysis technology. Nevertheless, the experience of long-term operation of such electrolyzers made it possible to accumulate and analyze data on the negative effect of various factors on the course of electrolysis and on the current efficiency. In particular, a harmful effect on the course of electrolysis was shown:

- residual moisture in CaCl₂ loaded into electrolyzers;
- high air humidity;
- the presence of iron impurities in the electrolyte, which is a catalyst for the high-temperature hydrolysis of CaCl₂;
- the appearance of CaO in the electrolyte both in the form of a dissolved oxide and in the form of a suspension (increase in viscosity and decrease in the electrical conductivity of the electrolyte, anodic oxidation of carbon anodes, electrolyte slagging, etc.).

In 1902 Borhes and Stochem, and in 1909 Wöhler and Rodewold put forward the first hypothesis that calcium dissolved in the CaCl₂ melt exists in the form of CaCl subchloride [3], which is oxidized at the anode with chlorine to CaCl₂, and at the cathode it is reformed by the reaction:



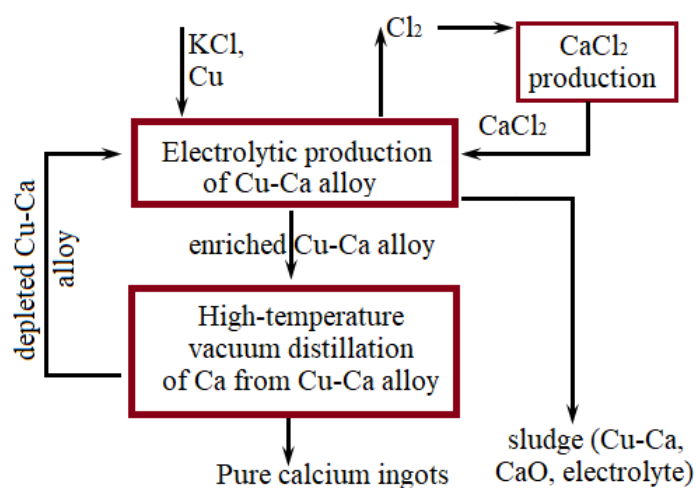

Figure 1 Scheme for the production of calcium by the electrolytic method.

Thus, a part of the electrolysis current is spent on recharging the $\text{Ca}^{2+} \leftrightarrow \text{Ca}^+$ ions, reducing the current output of calcium.

Based on these hypotheses, it was proposed to reduce the activity of CaCl in the electrolyte by lowering the activity of calcium, i.e. use the Ca–Me liquid cathode.

Taking into account the above observations, in 1946 Mikulinsky, Ioffe and Anglin developed a method for the electrolytic production of calcium on a Cu–Ca liquid-metal cathode in a CaCl_2 –KCl melt at 650 – 715°C [31]. Upon reaching the concentration of calcium in the cathode up to 65–75 wt% of it is removed from the cell, calcium is distilled off by vacuum distillation to a residual concentration of 20–30 wt% and returned to the cell. The main operations of this process are shown in Fig. 1.

3. Electrolyte for calcium production

3.1. Preparation of CaCl_2

The main electrolyte component in the electrolytic production of calcium is calcium chloride CaCl_2 (melting point 772°C [1–3]), to which KCl [32, 33], CaF_2 [34, 35] or NaCl [36, 37] is added to reduce process temperature, decrease in calcium solubility, increase in electrical conductivity, and modify other properties. The position of calcium in the electrochemical series of voltages of the elements necessitates the use of high purity CaCl_2 during electrolysis, which can be obtained in the following ways [1–3]:

1) Dissolution of limestone (more than 96.5 wt% CaCO_3) in dilute HCl, followed by purification of the

solution from impurities (MgSO_4 , MgCl_2 , FeCl_3 and AlCl_3) by converting them into insoluble hydroxides. After filtration, the solution containing 450 – 500 g l^{-1} CaCl_2 is sent for evaporation and drying.

2) Chlorination of milk of lime with anode gases to form CaCl_2 and $\text{Ca}(\text{ClO})_2$. The latter is converted into chloride using catalysts from a mixture of $\text{Ni}(\text{OH})_2$, $\text{Cu}(\text{OH})_2$, and $\text{Fe}(\text{OH})_3$ hydroxides in a weakly alkaline medium. After filtration, the CaCl_2 solution is evaporated into salt and dried with hot air at 300 – 320°C .

For additional purification of CaCl_2 , the hydrochlorination method can be used, which consists in the stage-by-stage heating of a mixture of calcium chloride with NH_4Cl to a temperature of 450 – 500°C [38, 39]. When heated, NH_4Cl decomposes into ammonia and gaseous HCl, which chlorinates CaO and $\text{Ca}(\text{OH})_2$ to CaCl_2 and water.

To obtain high-purity CaCl_2 in laboratory practice, chlorination of the melt is used by bubbling dried gaseous HCl and/or Cl_2 (preferably CCl_4) through it [40]. For the final stage of salt purification, the method of zone recrystallization in an argon atmosphere is increasingly used [41–44]. All further operations with anhydrous salt (grinding, weighing, loading into the reactor et al.) are carried out in a sealed glove box in an argon or nitrogen atmosphere.

The purity of the prepared CaCl_2 is checked by the magnitude of the "residual" current in the initial section of the cathode polarization curve obtained on an inert cathode [45].

3.2. Influence of CaO

The influence of CaO on the physicochemical properties of CaCl_2 is of interest, since the oxide can enter the electrolyzer together with underpurified CaCl_2 . Also, the CaCl_2 –CaO system seems promising for the developed methods for producing calcium, metals and alloys from the corresponding oxides: on a hypothetical inert anode, pure oxygen is supposed to be released instead of chlorine, which makes the process of electrochemical production of calcium one of the environmentally friendly technologies [46, 47].

The CaCl_2 –CaO phase diagram has been extensively studied by various authors in [3, 46–51], and the diagram

obtained in [51] is considered the most reliable. According to it, the solubility of CaO in CaCl₂ at 770°C is about 7.8 mol%. Despite the high solubility, all researchers noted a low CaO dissolution rate associated with complexation processes [52, 53]. Thus, to determine the electrolysis parameters of the CaCl₂-CaO melt, reliable data on the rate of CaO dissolution are needed, which are currently not available. To perform thermodynamic estimates, an expression was obtained in [49] for calculating the CaO activity coefficient ($\ln\gamma_{\text{CaO}}$) in a homogeneous CaCl₂-CaO melt in the temperature range 1123–1223 K: $\ln\gamma_{\text{CaO}} = 0.6064 + 840$.

There are practically no data on the effect of CaO on the physicochemical properties of CaCl₂ in the literature. According to [54], the appearance of CaO leads to an increase in the density of the CaCl₂ melt (see Table 1). Based on the concepts of halide oxide melts, it can be assumed that with the addition of CaO, the electrical conductivity and surface tension of the melt will decrease, while the viscosity will increase. Thus, the appearance and accumulation of CaO in the electrolyte of the current production will lead to:

- increasing the density of the electrolyte and reducing the allowable maximum concentration of calcium in the cathode alloy;

Table 1 – Physicochemical properties of the CaCl₂ melt with the addition of CaO

Property	CaCl ₂	CaCl ₂ - 2 mol% CaO	CaCl ₂ - 5 mol% CaO	CaCl ₂ - 9 mol% CaO
Density at 800°C, g cm ⁻³ [54]	2.055	2.070	2.091	2.121
Calcium solubility at 850°C, mol% [55, 56]	2.6	1.9	1.6	1.5
Electrical conductivity at 800°C, Ohm ⁻¹ cm ⁻¹	2.116 [54]	decreases with addition of CaO		
Viscosity at 800°C, mN·s m ⁻²	3.07 [54]	increases with addition of CaO		
Surface tension at 800°C, N m ⁻¹	146.9 [54]	decreases with addition of CaO		

- decrease in electrical conductivity and increase the voltage on the cell;

- decrease in the solubility of calcium and increase the cathodic output of calcium by current.

Experimental data on the effect of CaO on the technical and economic indicators of the process of electrolytic calcium production are also practically absent in the literature.

3.3. Alternative electrolytes

3.3.1. Chloride electrolytes

As noted above, binary and multicomponent mixtures of CaCl₂ with chlorides of alkali and alkaline earth metals are potential electrolytes for calcium production [32–37, 58–60]. When studying the solubility of CaO in such systems, the following regularities were revealed:

- The solubility of CaO decreases in a series of melts with the same concentration of components: CaCl₂ > CaCl₂-LiCl > CaCl₂-NaCl > CaCl₂-KCl.
- With an increase in the concentration of alkali metal chloride, the solubility decreases, and non-linearly.
- As the temperature of chloride mixtures rises, the solubility of CaO in them increases.

Thus, the transition to electrolytes with reduced CaO solubility and lowering the electrolysis temperature increase the tendency for undissolved CaO suspension to appear.

At the same conditions the addition of LiCl, NaCl, and KCl to the CaCl₂ melt leads to a decrease in its density, surface tension, and viscosity [54], which makes it possible to increase the maximum calcium content in the cathode Cu-Ca alloy [61–65].

3.3.2. CaCl₂-CaF₂-CaO system

A potential electrolyte for obtaining calcium from its oxide is the CaCl₂-CaF₂-CaO system, studied in detail in [34, 35, 66–68]. The phase diagram of the CaCl₂-CaF₂-CaO system has a eutectic point with parameters of 625°C and liquid phase composition (mol %): 79CaCl₂-17CaF₂-4CaO and a peritectic point at 660°C and composition (mol%): 67CaCl₂-23CaF₂-10CaO. At 700°C, there is a fairly large area of the liquid state (mol%): CaCl₂-(10–30)CaF₂-(10–

15)CaO. This system in the studied part is lower melting than $\text{CaCl}_2\text{-CaO}$, therefore it is of even greater interest for studying the processes of electrochemical production of calcium and developing new technologies.

In [66], there are data on the temperature dependence of the density of $\text{CaCl}_2\text{-CaF}_2\text{-CaO}$ melts containing 13.4, 25.8, and 37.4 mol.% CaO. The density of melts of the ternary system varies from 2.15 to 2.29 g cm^{-3} depending on temperature and CaO concentration. This is higher than the density of $\text{CaCl}_2\text{-CaO}$ and $\text{CaCl}_2\text{-KCl}$ systems. As well as for the $\text{CaCl}_2\text{-CaO}$ system, the main problem is the effective separation of the phase layers of the salt melt and the liquid calcium alloy.

According to calculations [52], all O^{2-} anions introduced into the chloride-fluoride melt in the form of CaO, after its dissolution, are in the composition of $[\text{Ca}_2\text{OF}_4]^{2-}$ and $[\text{Ca}_2\text{OF}_6]^{4-}$ complexes. In our opinion, the existence of mixed anionic $[\text{Ca}_2\text{OF}_2\text{Cl}_2]^{2-}$ complexes are possible in melts diluted with CaF_2 . Accordingly, the CaO activity coefficient in such melts should be less than unity.

3.4. Calcium solubility in CaCl_2

From a scientific point of view, interest in the phenomenon of the solubility of metals in their own molten salts was initiated as early as the beginning of the 19th century, when Davy in 1807 discovered the appearance of a red-brown coloration of the melt near the iron cathode during the electrolysis of KOH [69]. Subsequently, active research in this direction was due to the need for the development of electrochemical technologies for the production of alkali and alkaline earth metals and their alloys in terms of elucidating the reasons for the low current efficiency of metals during the electrolysis of the corresponding molten salts [3].

The solubility of calcium in CaCl_2 has been studied by many authors in different countries, but the numerical data differ significantly due to the use of different methods for preparing chloride and analyzing calcium in it [3, 55, 56, 71–77]. These works are described in detail in the monograph [3], and the measured values of calcium solubility are shown in Fig. 2.

In our opinion, the most reliable are the data on the solubility of calcium in CaCl_2 (C_{Ca} , mol.%) from [76];

depending on the reciprocal temperature, they can be described by the expression:

$$\lg C_{\text{Ca}}(t) = 2.29 - 0,21 \cdot 10^4 \cdot (t+273)^{-1}; (800-940^\circ\text{C}) \quad (2)$$

The average deviation of the experimental values from those calculated using Eq. (2) does not exceed 6 %.

As noted above, electrolytes for calcium production may contain CaO and additions of alkali metal chlorides, so the solubility of calcium in such systems has also been well studied [3, 56, 67, 75]. Calcium solubility values are shown in Fig. 3. As can be seen from Fig. 3, the addition of KCl and CaO reduces the solubility of calcium, while the addition of CaF_2 increases it. This may be due to the different energy states of the complex ions formed in the melt.

It is noteworthy that the solubility of calcium in $\text{CaCl}_2\text{-NaCl}$ melts is an order of magnitude higher than in the $\text{CaCl}_2\text{-KCl}$ system. In addition, the solubility of calcium in pure NaCl at 800°C is 9.67 mol% [3]. Apparently, the reason for such values is due to the exchange reaction $2\text{Ca} + 2\text{Na}^+ \leftrightarrow \text{Ca}^{2+} + 2\text{Na}$.

According to a number of works [8, 55, 56, 70, 76, 78], the dissolution of calcium in CaCl_2 occurs by reactions with heat absorption:

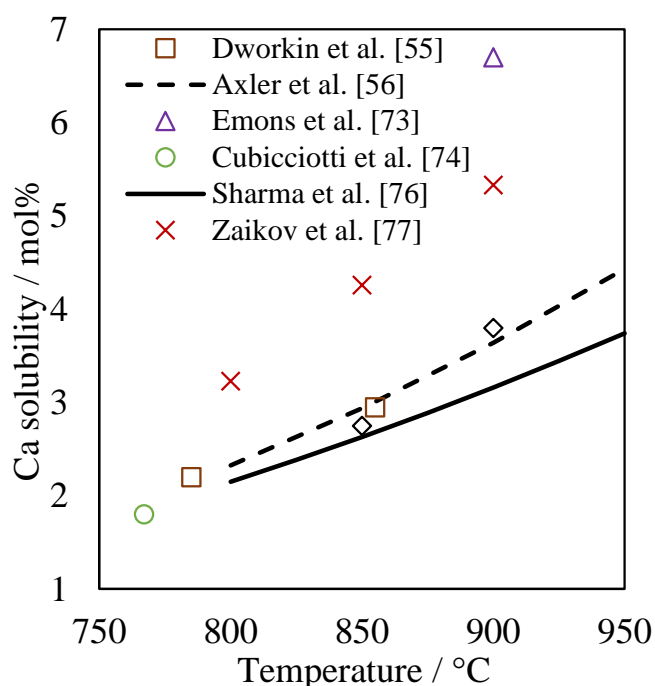

Figure 2 Calcium solubility in CaCl_2 as a function of temperature.

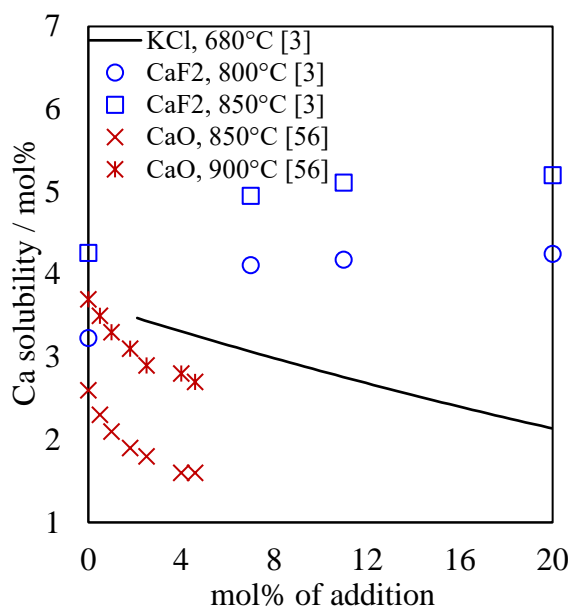
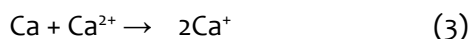

Figure 3 Effect of additives on calcium solubility in CaCl_2 melt.



This dissolution mechanism is indicated by the results of measurements of the specific electrical conductivity of CaCl_2 -Ca solutions at 855°C [55], according to which the electrical conductivity of solutions in the range of dissolved calcium concentrations up to 2.9 mol% increases only by 17.2%. Such an insignificant contribution of the electronic conductivity against the background of the ionic one (at a constant temperature) is due to the high degree of electron localization on the Ca^+ or Ca_2^{2+} ions. Also, according to cryoscopic studies, the freezing point of the CaCl_2 -Ca mixture is lower than the solidus temperature of pure salt [55, 78]. This refutes the hypothesis of atomic dissolution of calcium in its chloride.

4. Cathode processes in melts based on CaCl_2

Earlier it was noted that it was not possible to obtain calcium by electrolysis of melts with satisfactory technological parameters due to its high solubility in salt. The two-stage process turned out to be the most acceptable, when a Cu-Ca alloy is obtained by electrolysis, from which calcium is then extracted. In this case, the activity of calcium as a result of alloy formation can be reduced, thereby reducing the effect of side processes and using the electrolysis of melts with an acceptable yield of calcium into the alloy. Nevertheless, to understand the laws governing the electrolysis of CaCl_2

melts, it is of interest to study the cathode process both on indifferent and interacting electrodes.

It should be noted that reliable information on the regularities of the cathodic process in CaCl_2 melts is extremely limited due to the hygroscopicity of the salt and the neglect of the presence of calcium subions in the electrolyte.

4.1. Cathode process on indifferent cathodes

At the CaCl_2 -based melt electrolysis the near cathode layer acquires the properties of ion-electron liquid as the result of the Ca^{2+} ion reduction and metal dissolution according to reaction (3) [55, 78-80]. Due to the fact that such melts have both ionic and electronic conductivities, there is of interest how it will influence the kinetics and mechanism of cathode processes.

Fig. 4a demonstrated the stationary polarization dependencies obtained on the indifferent cathodes (W, Mo, Fe) at 800°C in the CaCl_2 melt [81]. Even in the thoroughly purified (especially from moisture) melt the mixture reduction currents are significant (to $10^{-2} \text{ A cm}^{-2}$). The polarization character of calcium-indifferent cathode made of different materials is the same. The linear area with a constant slope up to the calcium extraction potential ($\approx 3.28 \text{ V}$ at 800°C), is described by Tafel equation $\eta = a + b \ln i$. The calculations demonstrated that the calcium cation discharge at this area proceeds with one electron. Increasing electrolysis temperature leads to the cathode potential shift to the positive area and discharge current growth, which can exceed 0.3 A cm^{-2} at 800°C [81]. Thus, the cathode process at the CaCl_2 electrolysis takes place at diffusion regime. It can be represented in general form. At the initial moment at current load the calcium ion reduction process takes place according to reaction:



It will proceed until the Ca^+ ion concentration equal to its solubility is reached in the near cathode layer of the melt. Then two processes, which lead to calcium formation, take place at the cathode:



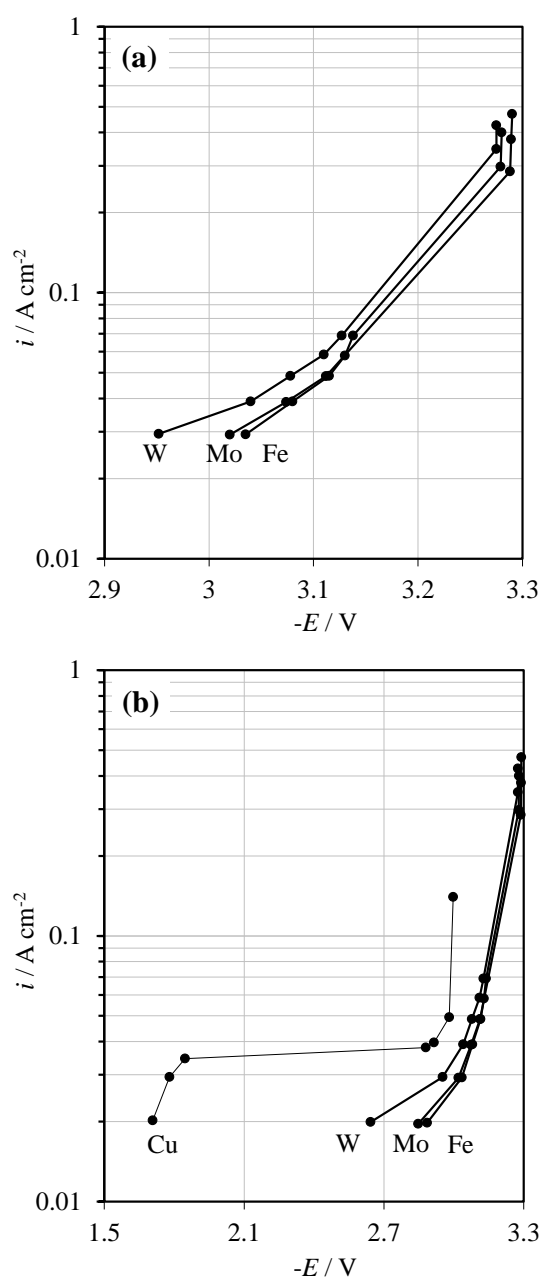

Figure 4 Stationary polarization dependencies for Cu, W, Mo, and Fe cathodes in molten CaCl_2 at 800°C [81]. Chlorine reference electrode.

A fraction of each process in the cathode process is defined by kinetic factors. The potential of the indifferent cathode during reaction [19] acquires the value of the melt redox potential:

$$E = E_{\text{Ca}^{2+}/\text{Ca}^+}^* - \frac{RT}{zF} \ln\left\{\frac{[\text{Ca}^{2+}]_s}{[\text{Ca}^+]_s}\right\} \quad (8)$$

where $[\text{Ca}^{2+}]_s$ and $[\text{Ca}^+]_s$ are the molar concentrations of Ca^{2+} and Ca^+ ions near the cathode surface (mol cm^{-3}), z is the number of electrons taking place in the cathode reaction, $E_{\text{Ca}^{2+}/\text{Ca}^+}^*$ is the conventional standard potential

(V), F is Faraday's constant ($F = 96487 \text{ C mol}^{-1}$), and T is the temperature (K).

Presence of the conductivity electron compound greatly influences the melt transport properties. The values of the D diffusion coefficient of Ca^+ subions, which were assessed from the chronopotentiograms [82], at $820\text{--}1000^\circ\text{C}$ were $1.1\text{--}1.7 \cdot 10^{-3} \text{ cm}^2 \text{ s}^{-1}$, which is twice orders higher than that of Ca^{2+} cations. The electron conductivity of $\text{Ca}\text{--}\text{CaCl}_2$ is not influenced by the redox processes in the near cathode layer and at some distance from the electrode surface [82]. It is one of the reasons of the current efficiency decrease during the calcium production by electrolysis. The Ca dissolution in CaCl_2 is accompanied with its dissociation on the Ca^+ subions, which interact with dissolvent ions, forming complex ionic groups and solvated electrons. The current efficiency can be assumed to be high at high current ($5\text{--}10 \text{ A cm}^{-2}$) that will allow producing calcium by the CaCl_2 electrolysis.

In the production of calcium and its alloys, the most interesting are melts based on a mixture of CaCl_2 and KCl , due to the fact that the potential for potassium release is more negative than the potential for calcium release. This makes it possible to use KCl to lower the liquidus temperature of the electrolyte. A study of the kinetics and mechanism of cathodic processes in $\text{KCl}\text{--}\text{CaCl}_2$ melts showed that the main patterns characteristic of CaCl_2 electrolysis are also inherent in these melts, but taking into account changes in the activity (concentration) of calcium ions.

Fig. 5 shows the results of measuring the polarization of the molybdenum cathode in the $\text{CaCl}_2\text{--}\text{KCl}$ melt (20 wt%) at 800°C , from which it follows that with the addition of KCl , the charge exchange current somewhat decreased, and the calcium release potential shifted to the negative region [83].

The effect of KCl on the calcium current efficiency will be noticeable at relatively high current densities, since its release potential is more than 0.2V more negative than in pure CaCl_2 . There are no experimental results on the effect of KCl on the current efficiency of calcium on indifferent electrodes, but its effect can be judged from the potassium content in the $\text{Cu}\text{--}\text{Ca}$ alloy (about $10^{-2}\text{--}10^{-3} \text{ wt}\%$).

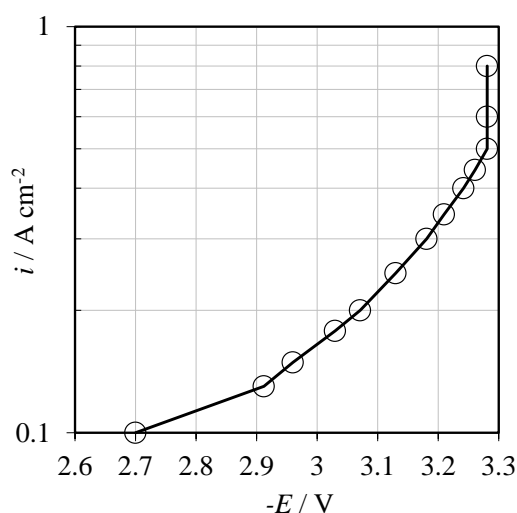

Figure 5 Polarization of the molybdenum cathode in the CaCl₂-KCl melt (20 wt%) at a temperature of 800°C [83].

Voltammetric studies of the cathode process in the CaCl₂-based melts [84–90] also show the presence of the reaction (voltammogram peak) preliminary to the metal calcium extraction according to reaction (5). However, the authors of these works consider that this reaction is the “electro-deoxidation” of oxides present in the CaCl₂ melt contacting the indifferent cathode (current lead). It will be discussed below.

4.2 Cathode process on interacting cathodes

Calcium electroextraction at the calcium-interacting cathodes is accompanied by the significant depolarization, appearing due to the alloy formation and calcium activity decrease. The advantage of such cathodes is a significant decrease in reverse calcium dissolution, the alloys may be used independently for metallurgical application [1–3, 91–94].

The main characteristic of the calcium alloy production electrolysis is that the process rate depends not only on the melt transport properties, but also on the rate of calcium extraction from the surface to the alloy bulk. The processes can be influenced by the liquid-metal electrode surface tension dependence on the electrode potential value and electromagnetic melt mixing at high current loads.

Let us analyze the role of depolarization at calcium alloys production. The potential of calcium extraction according to reaction (7) on the indifferent cathode is equal to:

$$E = E_0 + RT/2F \ln a_{\text{Ca}^{2+}} \quad (9)$$

and on the interacting liquid-metal electrode it is:

$$E_1 = E_0 + RT/2F \ln \{ [a_{\text{Ca}^{2+}}] / [a_{\text{Ca}^0}] \} \quad (10)$$

where E_0 is the standard potential of calcium reduction (V); $a_{\text{Ca}^{2+}}$ and a_{Ca^0} are the activities of Ca²⁺ ions in the melt and calcium metal in the alloy (mol cm³).

The difference between the E and E_1 is equal to the depolarization value:

$$\Delta E = -RT/2F \ln [a_{\text{Ca}}] \quad (11)$$

Thus, the depolarization value is determined by the alloy thermodynamics and composition on the interface with the melt. During the electrolysis process its value will decrease as a_{Ca^0} increases.

The polarization curves on the calcium-interacting cathodes in the CaCl₂-based melts have several characteristic areas of reduction of these metal cations, which appeared in the melt because of corrosion, at potentials from 1.7 V (especially Cu) by reaction (5) and calcium extraction with depolarization (see Fig. 4b, curve for Cu [81]). Formation of solid intermetallic compounds at the surface of liquid melt can also influence the character of the polarization curves. Thus, the calcium-rich alloy, which concentration change is negligible due to the decelerated calcium extraction from the surface to the bulk of the melt, is formed near the calcium extraction potential on copper at the cathode surface. The values of depolarization of calcium extraction, for example, on the solid copper, hard zinc, and cadmium were 0.28 [81], 0.78 and 0.75 V [92], respectively.

The solubility of calcium from the alloy to the CaCl₂ melt remains high [93]. Therefore, cathode processes, taking place at alloy production will be described by regularities common for calcium extraction at the indifferent electrode considering depolarization and diffusion difficulties, appearing at calcium extraction to the alloy bulk.

The kinetics of alloy formation depends on the rate of removal of calcium from the surface into the bulk of the alloy; the latter, in turn, is determined by the calcium diffusion coefficient and the thickness of the diffusion layer in the liquid alloy. It can be greatly reduced by

forced mixing of the liquid alloy. Of greatest interest from the point of view of practical application are Cu–Ca alloys, which are used in the production of calcium and as deoxidizers and desulfurizers in the production of copper.

4.3. Cathode current efficiency in the production of Cu–Ca alloy

The most significant impurities that noticeably affect the process of obtaining calcium and its alloys are the hydrolysis products of CaCl_2 - oxide and hydroxides, which were not completely removed during the dehydration of calcium chloride, or were formed as a result of interaction with air moisture during electrolysis [3, 81]. In addition, when graphite anodes are used, the formation of carbonate ions in the electrolyte seems inevitable [95–100]. Also, undesirable is the presence of nitrogen in the electrolyzer, which leads to contamination of calcium with nitride [101–103].

In electrolyzers with a relatively high current strength (25–50 kA), the cathode Cu–Ca alloy is intensively mixed due to electromagnetic fields. This contributes to a decrease in the thickness of the diffusion layer in the alloy, intensification of the removal of calcium into the volume of the alloy, and even at a current of side processes (3) and (4) of 0.5 A cm^{-2} , the cathodic current efficiency of calcium reaches about 75% [1–3]. On the basis of studies [104–106], carried out in a sealed cell, it was shown that the increase in current efficiency is facilitated by:

- electrolysis of the CaCl_2 melt in a pulsed mode;
- decrease in the content of CaCl_2 hydrolysis products (CaO , Ca(OH)_2 and Ca(OH)Cl) in the electrolyte;
- insulation of the inner walls of the cell body above the level of the Cu–Ca alloy, for example, using a ledge.
- decrease in temperature and increase in the interelectrode distance.

Taking into account that the cathode process proceeds without noticeable concentration polarization, and the surface of the bath walls under the cathode potential is large, it can be stated with a greater degree of confidence that the main reason for the decrease in current efficiency is the discharge of Ca^{2+} to Ca^+ and the

oxidation of the latter by chlorine in the volume of the melt or on the anode.

The technological advantages of using pulsed current in the electrolysis of ionic melts with liquid cathodes were shown in [107–109]. However, the use of pulsed current on an industrial scale is complicated by the current lack of the necessary electrical devices for such large current loads.

4.4. On the reduction of oxides during electrolysis of melts based on CaCl_2

One of the currently actively studied areas of application of the electrolysis of melts based on CaCl_2 – CaO is the reduction of oxides to the corresponding metals and alloys. Since the 1970s, the electrolysis of CaCl_2 – CaO melts has been used for the secondary reduction of oxides [110–112] according to reactions, for example:

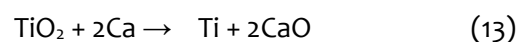

Since 1961, the possibility of purifying copper, titanium, and niobium from non-metals in CaCl_2 – CaO – Ca , CaCl_2 – Ca , and CaF_2 – Ca melts has been studied [113–115]. It was shown that the rate of metal purification from impurities is controlled by the stage of its diffusion in the metal phase and depends on the length of the diffusion path, the diffusion coefficient of the impurity, the temperature and time of the process. In 1998, British scientists Frey, Farthing and Chen proposed a method for removing oxygen, sulfur and other non-metals from solid and liquid metals by electrolysis of molten salts (CaCl_2 – CaO , BaCl_2 – BaO) [116], according to the reaction:

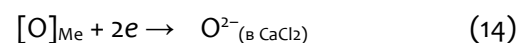

which gave rise to active study of the so-called "electrodeoxidation" or "FFC-Cambridge process" [84–90]. The essence of the process is the reaction of direct reduction of metal ions by electrons according to the reaction, for example:

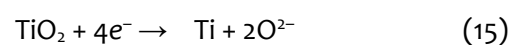

The correctness of this mechanism was substantiated by the authors by the fact that the process is fixed at

potentials more positive than the calcium release potential [84–90].

Against the concept of direct reduction of any non-conducting oxide on the cathode according to reaction (15), the following arguments can be made [117, 118]:

1 - the real area of contact of individual oxide crystals with the cathode surface is negligible;

2 - taking into account item 1, the probability of a contact transition of an electron from the cathode to a non-conducting crystal, or rather to a separate cation of the crystal, becomes negligible in order to reduce it to a metal or ion of the lowest oxidation state;

3 - the cathodic process even in a high-purity CaCl_2 melt on indifferent substrates takes place already at potentials 0.4–0.5 V more positive than the calcium release potential [3, 81, 83], while in the near-cathode space a CaCl_2 -Ca solution is formed, which is an ion-electron liquid [55, 56, 78] (similar patterns are characteristic of the electrolysis of all melts of chlorides of alkali and alkaline earth metals [119–121]).

Considering the above arguments, we can conclude that the strength of the electrolysis current required for the implementation of reaction (15) must be negligible. As a result, the process of reduction of salt-solvent ions according to reaction (5) must begin at the cathode. Ca^+ ions are able to reduce any oxide (more precisely, cations in its crystal lattice), while the O^{2-} anion must diffuse from its surface into the melt, be transported with electrolyte flows to the anode, and be discharged on it to oxygen or CO_2 . The original oxide can be reduced in one step:



or in several stages:

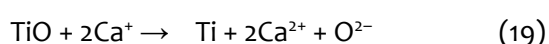
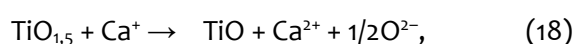

Important conclusions follow from the above ideas [117].

1. Reactions (16)–(19) are chemical and can occur not only near the cathode, but also in the bulk of the

electrolyte near the cathode layer, i.e. catholyte, especially during long-term electrolysis.

2. In the process of electrolysis, the highest concentration of the reducing agent Ca^+ is constantly reproduced at the cathode, therefore, the oxide reduction front moves in the direction from the cathode to the anode, which creates the illusion of an electrochemical reaction of the type (6.9) for the observer.

3. Some electrically conductive oxides, for example, FeO , Fe_3O_4 , Cu_2O , can be electrochemically reduced by a reaction of the type (15) at the cathode and outside it, if the crystals of such oxides are in electrical contact with each other.

4. The solubility of CaO in molten CaCl_2 is high; nevertheless, the O^{2-} ions formed as a result of reactions (16)–(19) can accumulate near the cathode in a concentration greater than the CaO solubility product requires, and this oxide can form crystals near the cathode or double oxide crystals of $\text{Ca}_x\text{Me}_y\text{O}_z$ type on the surface of simple oxides. This factor greatly reduces the overall rate of oxide reduction, which is observed by many researchers in their experiments. The formation of double oxides can also take place without electrolysis if the CaCl_2 salt was not thoroughly purified from CaO .

5. From paragraph 4, it follows that the detection of CaO in the reduced metal is not direct evidence of the reduction of oxides by reactions (13)–(19).

6. In a number of works, to lower the temperature of the FFC process, it is proposed to use mixtures of CaCl_2 with KCl , NaCl , BaCl_2 , KF , CaF_2 [122–125]. Lowering the CaCl_2 liquidus temperature by adding KCl and NaCl has negative consequences:

(a) – the solubility of CaO in melts decreases, which increases the probability of the formation of double oxides on the surface of simple ones;

(b) – with decreasing temperature, the stage of solid-phase diffusion of O^{2-} ions from the volume of oxides to their surface slows down for the subsequent transition to the salt melt.

Both factors cause a decrease in the overall rate of the oxide reduction process.

The use of mixed melts of $\text{CaCl}_2\text{-BaCl}_2$ and $\text{CaCl}_2\text{-CaF}_2$ increases the solubility of CaO in them, reducing the probability of formation of double oxides, which, in turn, should have a favorable effect on an increase in the overall rate of the oxide reduction process.

5. Anode processes in melts based on CaCl_2

5.1. Carbon anodes

The anode process on carbon in the chloride melts can be described by the following physical steps [3, 126]. Formation of the chlorine bubbles begin after the saturation of the layer near the carbon anode with dissolved chlorine at low current densities. The formation, growth and removal of the bubbles are observed mainly from the pores, hollows and cracks. With increasing current density, the energy irregularity of the anode surface decreases, a number of chlorine bubble nucleation centers increases, and their distribution becomes more uniform.

The primary anode process on the carbon in molten CaCl_2 is:



Today it is common to associate the anode overpotential with adsorption-desorption reactions at the electrode surface. In the chloride melts these are the chlorine atom adsorption (21), recombination (22) and electrochemical desorption (23):

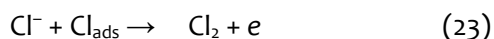
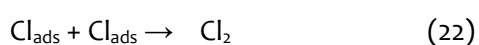

Depending on the experimental conditions the rate of the common anode process can be limited by steps (22) and/or (23). After reaching the critical anode current density anode effect occurs, accompanied by an increasing of the electrode resistance, an increasing the cell voltage, and an abrupt current drop.

Studying the anode process is accompanied by the oxidation of Ca^+ ions present in CaCl_2 -based melts [55] to Ca^{2+} ions at the anode (up to $0.3\text{-}0.6 \text{ A cm}^{-2}$). Also, the chemically oxidation of Ca^+ ions occur near the anode

surface layer saturated with chlorine according to the reaction:

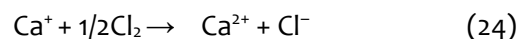

The anode process on carbon becomes more complicated at the addition of CaO in molten CaCl_2 . Two consequent electrochemical steps [127, 128]:

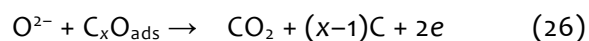
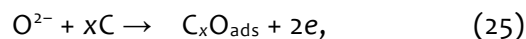

can be limited by the preceding formation of the oxide-chloride complexes during the CaO dissolution in molten CaCl_2 . Potentiostatic investigations of the carbon anode behavior in $\text{CaCl}_2\text{-CaO}$ melt [128] showed that anode process includes a number of steps, associated with the CO , CO_2 , Cl_2 gases evolution, and also with the COCl_2 gas evolution at high anode current densities.

Part of CO_2 from the reaction (26) dissolves in the melt near the anode surface with the formation of CO_3^{2-} anion, which may be discharged at the anode or transferred to the cathode by the melt flow, where it is discharged to form the dispersed carbon in the melt:

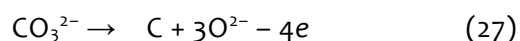

A part of carbon from the reaction (27) can react with CO_2 dissolved in an anolyte with the formation of CO which is removed from the cell together with the anode gases. However, the interaction of carbon with Ca^+ ions near the cathode is most likely:

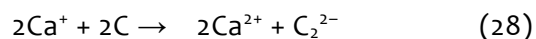

It follows from the above that the using carbon anodes at the electrolysis of $\text{CaCl}_2\text{-CaO}$ melts in cells without separation of anolyte and catholyte leads to the changes in the physical-chemical properties of the melt and to decreasing of the values of anode and cathode current efficiencies, especially at low currents [84–90].

5.2. Oxygen-evolving anodes

Due to the high solubility of CaO in CaCl_2 melt [51] oxygen-evolved anodes can be studied at the

electrolysis of $\text{CaCl}_2\text{-CaO}$ melts. The solution of this problem will allow replacing anhydrous CaCl_2 by the cheaper CaO material and creating ecologically pure process with oxygen evolving at the anode. The behavior of oxide anodes of different composition in the $\text{CaCl}_2\text{-(5 wt\%)\text{CaO}}$ melt were studied at 800°C both under current load and without current load [129, 130]. Li_2O -doped NiO (resistivity $0.1\text{-}0.01 \Omega\cdot\text{cm}$) was found to be the best material; for the following studies according to the values of electric conductivity and corrosion resistance at the electrolysis.

Fig.6 demonstrates polarization dependencies of the $\text{NiO-Li}_2\text{O}$ anode on the CaO concentration in the melt and cell atmosphere. At high current densities chlorine evolves and the anode surface becomes covered by green NiO film. Under otherwise equal conditions the limiting current of O^{2-} ion discharge is lower in the helium atmosphere than in the oxygen atmosphere. The slope of the polarization curve 2 changes before the limiting current is applied. The slopes of initial parts of the curves match.

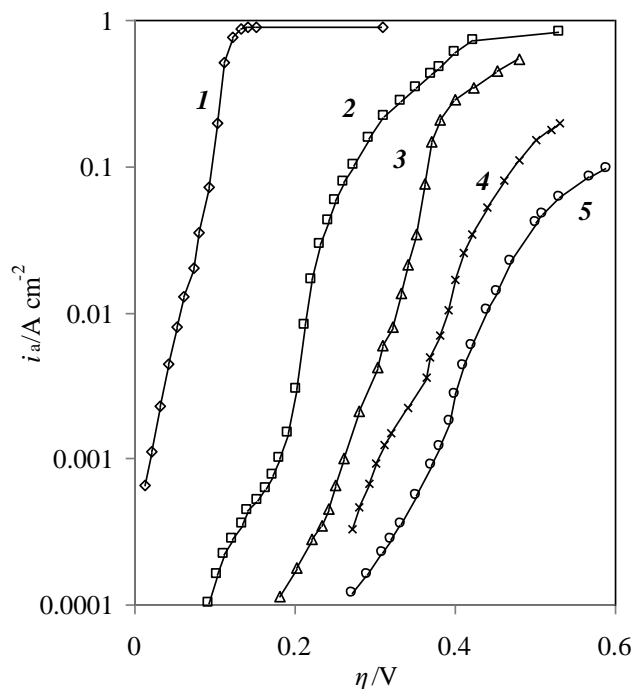
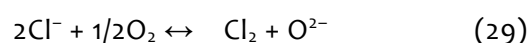

Figure 6 Polarization dependencies obtained on $\text{NiO-Li}_2\text{O}$ anode in molten $\text{CaCl}_2\text{-CaO}$ under different atmosphere (O_2 , He) at 800°C with the CaO concentrations, mol%: 1 – 9.4 (O_2); 2 – 9.4 (He); 3 – 3.9 (He); 4 – 1.9 (He); 5 – 0.8 (He). Chlorine reference electrode [129].

Effect of helium can be explained by:

1 – its adsorption at the anode surface, which leads to the surface area decreasing, where O^{2-} ions are discharged and O_2 evolves. At low current densities helium adsorption does not influence on the overpotential value, as areas, which are not occupied by helium are sufficient for O^{2-} ion discharge;

2 – the processes at the three-phase boundary (gas-anode-melt). They can significantly influence the anode process current generation, because of the simplified extraction of O_2 at the anode and oxide ions supply to the reaction area, which are formed at the gas-melt interface according to the exchange reaction:



At the analysis of the mechanism of the O^{2-} ion discharge at the oxygen-evolving anode authors (12) divides the total reaction:

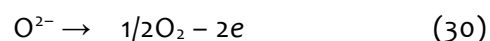

on the O^{2-} ion diffusion from the melt bulk to the anode surface:



the oxygen ion discharge with the adsorbed atom formation:



recombination:



electrochemical desorption:

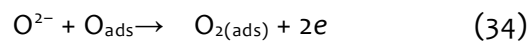

and detachment of molecular oxygen:



The model simulation of the anode process kinetics at the oxygen-evolving anode demonstrated that the polarization dependencies of the limited recombination (33) and electrochemical desorption (34) have qualitatively the same form. Moreover, the calculated curve better coincides with the

experimental one during the limited recombination (12).

The obtained experimental data and results of the theoretical calculations allow concluding that adsorption-desorption reactions at the anode surface are limiting ones. To clarify the studied process mechanism additional research using the non-stationary methods to study kinetics is required.

Corrosion of the oxide electrode is due to both chlorine ions discharge resulting in its direct chlorination and secondary reaction (29) [130, 131], which resulted in chlorine formation that can interact with the oxide anode. The rate of reaction (29) decreases as the CaO concentration in the melt increases and as CaF₂ and (3–6) mol.% CaO are added no chlorine is observed in oxygen in the output. The CaF₂ influence may appear because of complex formation. To specify the nature of the effect under study further research is necessary.

The relevance of the oxygen-evolving anode development for the CaCl₂–CaO melt electrolysis is reported in the later works [132–134]. Basing on the preliminary studies within a number of metals (W, Mo, Ni, Fe, Au, Pt, Ag, Ru and other) and oxides, NiFe₂O₄ and CaRuO₃ spinels are suggested as the most perspective anode materials.

5.3. Anode dissolution of Cu–Ca alloy

In the existing technology for obtaining calcium using a copper-calcium alloy, high-temperature distillation of calcium is very energy-consuming, an alternative to which can be the extraction of calcium from the alloy by electrolysis [3, 135–138].

The anodic process on the Cu–Ca alloy can be accompanied by a number of reactions that determine the current output of calcium:

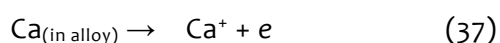
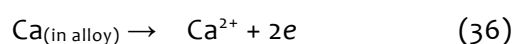

In addition, an adverse reaction may occur:

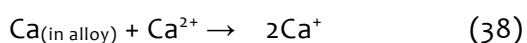

At high current densities and low calcium concentration in the alloy, copper ionization cannot be completely excluded:

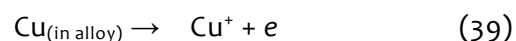

The share of reaction (38), due to the large difference in the standard potentials of Cu and Ca, will be insignificant, but since copper is an undesirable impurity in the final product - calcium, its role cannot be ignored.

Experiments at low anode current densities showed that the anode current efficiency during ionization of an alloy containing 45 wt% Ca calculated for the two-electron process varied from 112 to 135% (the anode current density was 0.3 A cm⁻², t = 855°C), which indicates a large proportion of reaction (37) [135].

6. Proposed technologies for the electrolytic production of calcium

Information about new methods and technologies for the electrolytic production of calcium in the sources of patent and scientific information is practically absent due to the complexity and closeness of such developments. In Russia, efficient electrolyzers of new designs were proposed and patented by the Institute of High-Temperature Electrochemistry, the Chepetsk Mechanical Plant, and the Machine-Building Plant [3, 137–144]. One of the latest developments is a 30kA calcium electrolyzer developed by Hanzhong Zinc Industry Specialty Materials Co Ltd in China [143]. The schemes, principles of operation and test results of these structures are summarized below.

6.1. Electrolyzer with the garnisage

Electrical separation of the cathode and anode spaces is possible with the help of a ledge formed from the electrolyte. Other materials are not suitable for this purpose due to the high chemical activity of calcium and electrolyte containing dissolved metal [77].

A diagram of an electrolyzer of this design for a current strength of 1.5kA is shown in Fig. 7. In it, the metal collector, which simultaneously acts as a cathode, and the bath with an anode alloy are electrically separated from each other by an asbestos gasket sandwiched between cooled flanges. The

ledge is formed at the start of the electrolyzer at the flange connection and serves as an electrical insulator. The condition for the operation of such an electrolytic cell is the excess of the liquidus temperature of the electrolyte over the melting point of calcium, so the design was tested on the example of the electrolysis of a $\text{CaCl}_2\text{-CaF}_2$ melt at $860\text{--}880^\circ\text{C}$. The pre-dried salts were melted in argon and transferred to an electrolyzer heated to $600\text{--}700^\circ\text{C}$ and filled with argon. Before that, an anode alloy containing 60–62 wt% calcium was loaded into the cell.

After reaching the required temperature, electrolysis was carried out, during which calcium was extracted from the collector. As a result of the work of the electrolyzer, the fundamental possibility of using the design for the production of calcium is shown. The technical and economic efficiency of calcium production was shown in comparison with vacuum distillation.

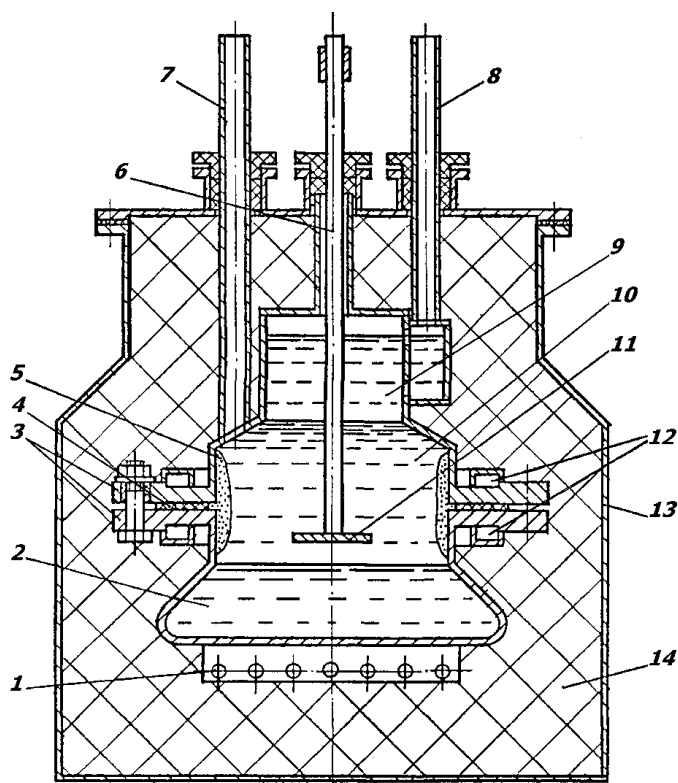

Figure 7 Electrolyzer with the garnisage: 1 – heaters; 2 – anode alloy; 3 – flanges; 4 – asbestos gasket; 5 – garnisage of salt; 6 – current lead; 7 – pipe for loading the anode alloy; 8 – pipe for extracting calcium; 9 – cathode; 10 – electrolyte; 11 – cathode; 12 – channels for heat removal; 13 – casing; 14 – thermal insulation.

6.2. Electrolyzer with solid calcium recovery device

The liquid calcium released on the inert cathode is collected near the cathode in the form of a ring, while the metal actively rotates around the cathode clockwise and radially in the sediment (Fig. 8) [1, 3]. With an increase in the volume of liquid calcium (up to the possibility of its extraction by the electrolyzer), a part of the metal can detach from the precipitate and oxidize at the anode, which leads to a decrease in current efficiency. In this regard, an electrolytic cell with a current strength of 0.5–1.5kA was made for the continuous extraction of calcium in the solid state according to the touch cathode principle [1, 3] (Fig. 9). A ring with vertical plates located at a certain distance was used as a cathode (Fig. 10). In the presence of such plates, the intensity of metal movement is reduced, which makes it possible to accumulate more metal at the cathode. To extract the metal, an air-cooled hollow rod was used, which was removed with frozen calcium through a sluice evacuated chamber. Due to the periodic extraction of calcium, the electrolyzer can operate without interruption for a long time under stationary conditions, while the cathode surface and cathode current density change insignificantly during electrolysis.

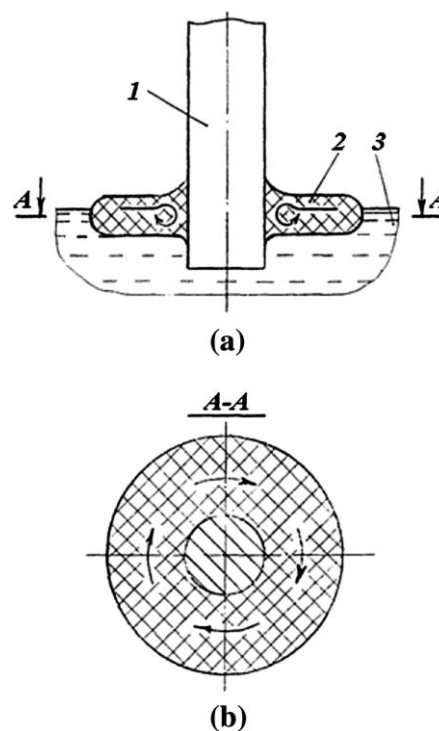

Figure 8 Scheme of the movement of calcium near the cathode a – side view; b – top view: 1 – cathode; 2 – liquid calcium; 3 – electrolyte.

6.3. Electrolyzer with continuous recovery of calcium in liquid state

Simultaneously with the electrolytic cell described above, an electrolytic cell was developed for extracting calcium in a liquid state. For this, an electrolyzer with a cathode in the form of a bowl was proposed (Fig. 11) [3, 139]. During electrolysis, calcium accumulates in a similar way around the bowl in the puddle and moves along the walls 50-100 mm high inside the bowl due to capillary (along the metal grid) and electrocapillary effects (wetting of the cathode with an increase in the cathode current density).

In addition to the simplicity and safety of operation of the device, its advantage over other designs lies in the prevention of electrolyte ingress into the cathode metal. The use of such a device was characterized by stability, which allowed us to conclude that the previously determined optimal parameters (anode current density, cathode current density, etc.) are also valid for such cell designs.

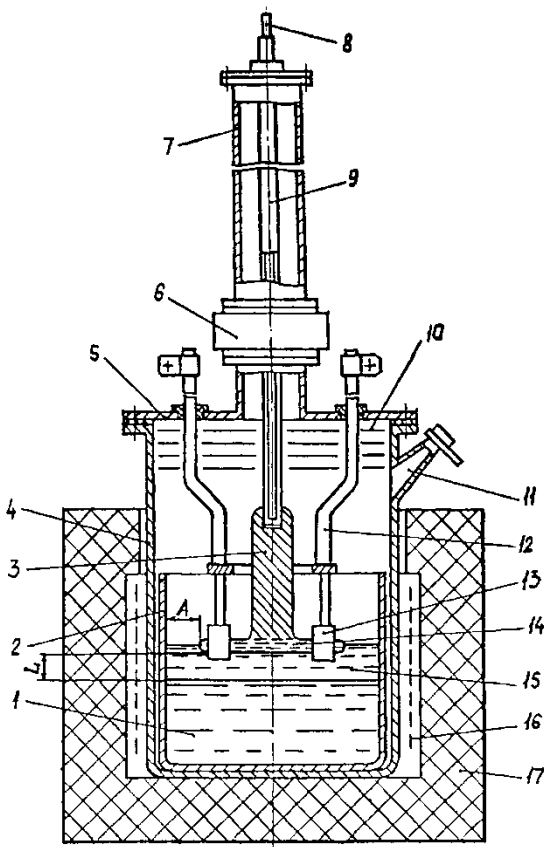

Figure 9 Electrolyzer: 1 – Cu–Ca alloy; 2 – bath; 3 – Ca rod; 4 – casing; 5 – cover; 6 – gateway; 7 – sealed chamber; 8 – pipe for air supply; 9 – metal case; 10 – screens; 11 – viewing window; 12 – current leads; 13 – cathode plate; 14 – "puddle" of calcium; 15 – electrolyte; 16 – heater; 17 – thermal insulation.

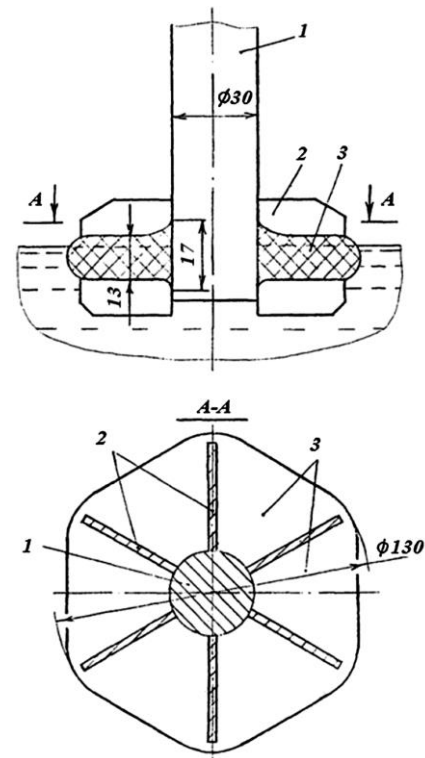

Figure 10 Cathode deposit with restrictive plates: 1 – cathode; 2 – limiting plates; 3 – liquid calcium

This concept is implemented in the form of an experimental electrolytic cell for 12–15kA (Fig. 12). The bath and the cathode in contact with the anode alloy, electrolyte and cathode metal were made of mild steel, the most resistant to these media. The remaining parts of the electrolyzer were made of stainless steel. Separate corrosion tests were carried out to determine the service life of the mild steel bath. They showed that St3 steel, in simultaneous contact with the alloy and electrolyte at 850–900°C, corrodes at a rate of 0.5–0.7 mm/year. Similar corrosion rates of St3 steel in Cu–Ca alloy were obtained in [145]. With a decrease in the carbon content in steel, the rate of its corrosion decreased.

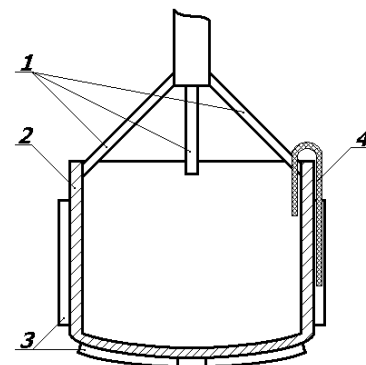

Figure 11 Cathode bowl: 1 – current leads; 2 – cathode bowl; 3 – ribs; 4 – metal mesh

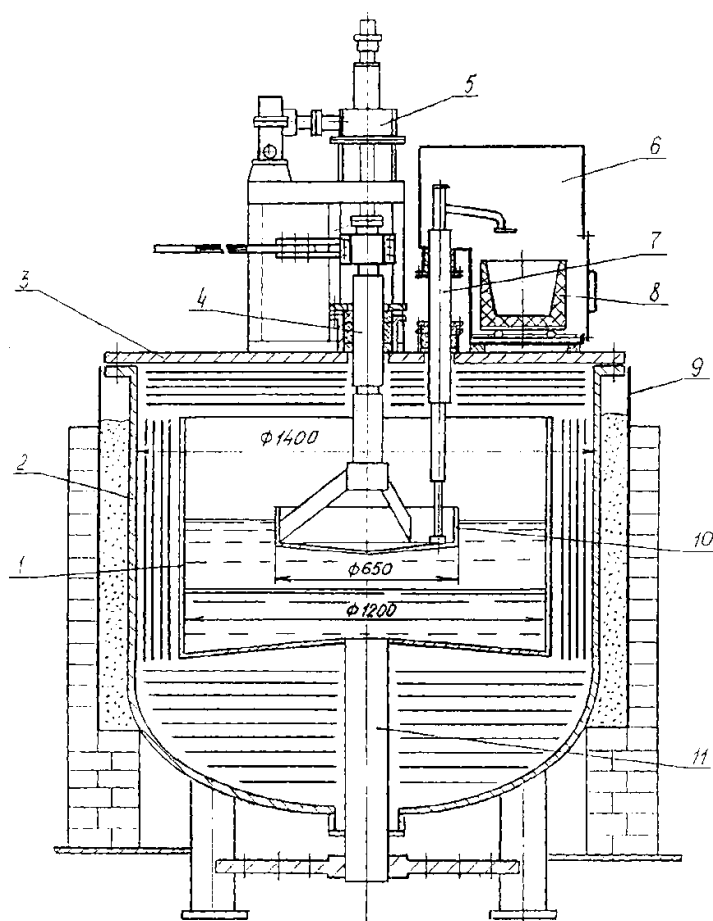

Figure 12 Experienced electrolyzer: 1 – bath; 2 – casing of the electrolytic cell; 3 – cover; 4 – current lead to the cathode; 5 – lift / holder; 6 – receiver; 7 – Ca outlet channel; 8 – Ca collector; 9 – protective shell; 10 – cathode bowl; 11 – current lead to the anode.

After modeling the heat balance of the electrolyzer and its experimental verification, the electrolysis was carried out with the following parameters [3, 137]:

current:	9–10 kA;
voltage:	no more than 6 V;
cathode current density:	2–6 A cm ⁻² ;
anode current density:	1 A cm ⁻² ;
operating temperature:	860–880°C;
operating pressure in the apparatus:	1 104 Pa;
cathode movement:	300 mm;
atmosphere:	argon;
Ca in alloy:	63 to 25 wt% Ca

6.4. Bipolar electrolyzer

To combine the processes of producing Cu–Ca alloy and calcium in one apparatus, a bipolar electrolyzer with a current strength of up to 3kA was developed (Fig. 13) [3, 142]. In the left compartment, the CaCl₂–KCl eutectic

mixture was used as an electrolyte, in the right compartment, the CaCl₂–CaF₂ melt. During electrolysis, the consumable component, CaCl₂, is loaded into the left compartment. Chlorine is released on the graphite anode, which is used to produce CaCl₂. Since the left compartment is airtight, the anode gases emitted contain a high concentration of chlorine (up to 93 vol%). The current efficiency of calcium in this compartment increases due to the fact that atmospheric moisture is quickly consumed and then does not affect the course of electrolysis. At the same time, the resistance of the graphite anode increases and its consumption is significantly reduced.

In the right compartment, calcium is released on the iron cathode, gradually accumulating on the electrolyte surface. As it accumulates through heated pipelines, calcium is extracted into a receiving tank using vacuum. All operations, including the electrochemical process of extracting calcium from its alloy with copper, are carried out in an inert gas atmosphere at a temperature of 860–870°C. The alloy is depleted in calcium and flows through the connecting pipeline into the left compartment due to the density difference. Parallel to this flow, an alloy enriched in calcium enters from the left compartment and, due to the difference in specific gravity, rises up, reaching the alloy–electrolyte interface. An MHD pump is provided for forced transfer of the alloy from one compartment to another. The liquid state of the alloy in the pipelines between the compartments of the cell is maintained due to its high thermal conductivity.

In this cell design, the Cu–Ca alloy functions as a bipolar liquid metal electrode.

The described technology has significant advantages compared to existing methods for obtaining calcium, but at present it has passed only laboratory tests.

6.5. 30kA electrolyzer

The scheme of the proposed electrolyzer for 30 kA is shown in Fig. 14 [143]. Greater productivity in comparison with the above-described electrolyzers in this design is ensured by optimizing the current supply to the liquid metal cathode and graphite anode: in both cases, copper insulated with ceramic tubes acts as the current supply materials. The cathode Cu–Ca alloy is placed in the recess of the iron cathode, in the upper part the alloy is enriched in calcium during electrolysis,

after which it is pumped out of the electrolyzer. The cell is reported to produce high purity calcium, but the copper content of the calcium pumped out is not reported.

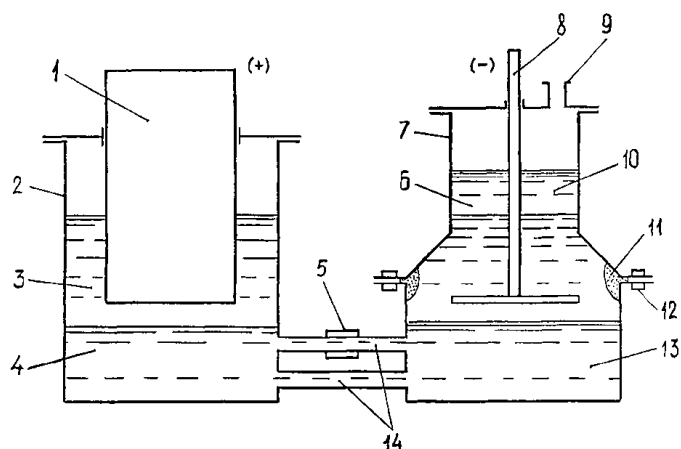

Figure 13 Scheme of a bipolar electrolyzer: 1 – carbon anode; 2 – alloy loading compartment; 3 – electrolyte; 4, 13 – Cu–Ca alloy; 5 – MHD pump for forced pumping of metal; 6 – calcium; 7 – calcium extraction compartment; 8 – cathode; 9 – hole for extracting calcium; 10 – calcium; 11 – garnisage; 12 – channels for the coolant; 14 – tubes for alloy circulation.

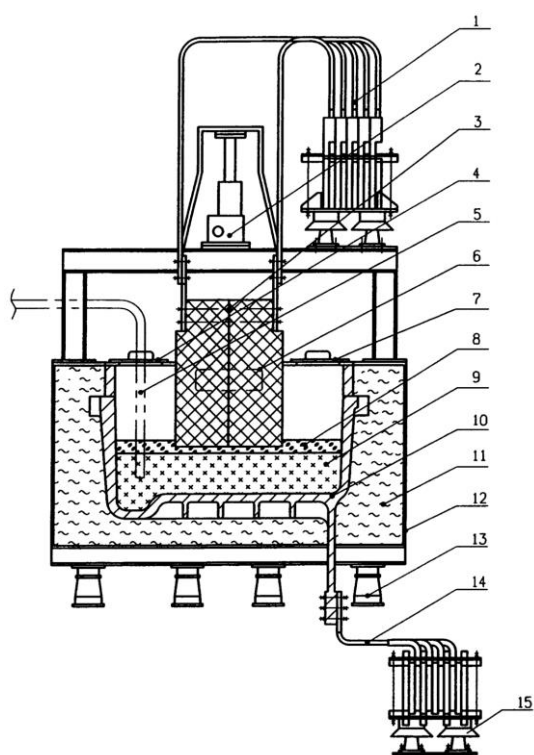

Figure 14 Scheme of the cell for a current of 30 kA: 1, 14 – copper current leads; 2 – anode lifter; 3 – openings for removing chlorine from the electrolytic cell; 4, 7 – hole for calcium pumping/sludge extraction; 5 – pipe for pumping out calcium; 6 – control of anode immersion; 8 – electrolyte; 9 – Cu–Ca alloy; 10 – cathode (cast iron/iron); 11 – thermal insulation; 12 – casing of the electrolyzer; 13, 15 – insulating supports.

A similar design of an electrolytic cell for the production of light alloys was proposed and tested earlier [144]. It was shown that its use makes it possible to achieve a current output of calcium of 75–78% while reducing energy costs.

7. Conclusions

Summarizing the above ideas about the current state of the electrolytic production of calcium, it can be noted that the base electrolyte and, at the same time, the source of calcium are melts based on the CaCl_2 system, which during electrolysis become ionic-electronic liquids due to the dissolution of calcium in them in the form of Ca^+ subions.

To date, there are reliable and well-established ideas about the mechanism of electrode processes during the electrolysis of melts based on CaCl_2 . It has been shown that chlorine is released at the carbon anode by the reactions of adsorption-desorption characterization, and on indifferent cathodes there is a two-stage discharge of calcium ions Ca^{2+} to calcium subions Ca^+ , and then, after saturation of the near-cathode layer with Ca^+ ions, metal calcium is released. On an interacting copper cathode, the electroreduction of calcium ions occurs with a depolarization of more than 1V, while the electrodeposition of calcium into the alloy makes it possible to reduce the activity of calcium and, accordingly, its solubility in the electrolyte. This was used in the development in the middle of the last century of the technology for the electrolytic production of calcium, which is still in operation.

The possibility of using an electrolyte based on the CaCl_2 – CaO system for the electrolytic production of calcium, as well as other metals and alloys from oxides using an oxygen-evolving anode, is noted. However, the development of such technologies requires the determination of the physicochemical properties of these electrolytes, a comprehensive study of the electrode processes in them, as well as the development of appropriate apparatus for implementation.

Possible ways of increasing the cathode current efficiency in the operating cell for the production of Cu–Ca alloy are given, as well as information on the methods and apparatus proposed to improve the efficiency of the

electrolytic production of calcium. The presence of such developments indicates the relevance of continuing research in the field of high-temperature electrochemistry of calcium.

Funding

This research had no external funding.

Acknowledgments

None.

Author contributions

Yuriy Zaikov: Supervision; Investigation; Data curation; Project administration.

Victor Batukhtin: Investigation; Data curation; Methodology.

Nikolay Shurov: Validation; Writing.

Andrey Suzdaltsev: Supervision; Conceptualization; Resources; Visualization; Formal Analysis; Writing – original draft; Writing – review & editing.

Conflict of interest

The authors declare no conflict of interest.

References

- Doronin NA. Kal'tsiy [Calcium]. Atomizdat: Moscow; 1962. Russian. 191 p.
- Rodyakin V.V. Kal'tsiy, yego soyedineniya i splavy [Calcium, its compounds and alloys]. Metallurgy: Moscow; 1967. Russian. 186 p.
- Zaikov YuP, Shurov NI, Suzdaltsev AV. Vysokotemperaturnaya elektrokhemiya kaltsiya [High-temperature electrochemistry of calcium]. RIO UB RAS: Yekaterinburg; 2013. 200 p. Russian. ISBN 978-507691-2350-4.
- Emsley J. The elements. Oxford University Press: New York; 1998. 292 p. ISBN 978-01985-5818-7.
- Turkdogan ET. Physical chemistry of high temperature technology. Academic Press: New York; 1980. 447 p.
- Emons HH, Anders D, Roewer G, Vogt H, Untersuchungen an erdalkalimetall-erdalkalimetallhalogenid systemen. VIII. Der einfluss des stickstoffs auf erdalkalimetallhalogenid - systeme, Z. Anorg. Allgem. Chemie 333(1-3) (1964) 99-107. <https://doi.org/10.1002/zaac.19643330114>. Deutsch.
- Ouchi T, Kim H, Spatocco BL, Sadoway DR, Calcium-based multi-element chemistry for grid-scale electrochemical energy storage, Nature Communications 7 (2016) 10999. <https://doi.org/10.1038/ncomms10999>.
- Richter D, Emons HH, Auflosung der erdalkalimetalle in ihren geschmolzenen halogeniden, Z. Chemie 6(11) (1966). 407-416. Deutsch. <https://doi.org/10.1002/zfch.19660061103>. Deutsch.
- Ellery A, Mellor I, Wanjara P, Conti M, Metalysis Fray Farthing Chen process as a strategic lunar in situ resource utilization technology, New Space 10(2) (2022) 224-238. <https://doi.org/10.1089/space.2021.0047>.
- Squires LN, Lessing P, Direct chemical reduction of neptunium oxide to neptunium metal using calcium and calcium chloride, J. Nucl. Materials, 471 (2016) 65-68. <https://doi.org/10.1016/j.jnucmat.2016.01.007>.
- Iizuka M, Inoue T, Ougier M, Glatz JP, Electrochemical reduction of (U, Pu)O₂ in molten LiCl and CaCl₂ electrolytes, J. Nucl. Sci. Technol. 44 (2007) 801-813. <https://doi.org/10.1080/18811248.2007.9711869>.
- Zhao J, Zhu H, Wang L, Song M et al., Effect of CaO/Al₂O₃ ratio on desulphurization and non-metallic inclusions in low-density steel, Ironmaking & Steelmaking 49(3) (2022) 302-310. <https://doi.org/10.1080/03019233.2021.1993695>.
- Liu H, Kang J, Zhao X, Zhang C et al., Influence of Ca treatment on particle-microstructure relationship in heat-affected zone of shipbuilding steel with Zr-Ti deoxidation after high-heat-input welding, J. Iron Steel Res. Int. 29 (2022) 1291-1298. <https://doi.org/10.1007/s42243-022-00791-7>
- Rong Z, Liu H, Zhang P, Wang F et al., The formation mechanisms and evolution of multi-phase inclusions in Ti-Ca deoxidized offshore structural steel, Metals 12 (2022) 511. <https://doi.org/10.3390/met12030511>.
- Hosein ID, The promise of calcium batteries: Open perspectives and fair comparisons, ACS Energy Letters 6 (2021) 1560-1565. <https://doi.org/10.1021/acsenergylett.1c00593>.
- Stievano L, De Meazza I, Bitenc J, Cavallo et al. Emerging calcium batteries, J. Power Sources 482 (2021) 228875. <https://doi.org/10.1016/j.jpowsour.2020.228875>.
- Ji B, He H, Yao W, Tang Y, Recent advances and perspectives on calcium-ion storage: Key materials and devices, Advanced Materials 33(2) (2021) 2005501. <https://doi.org/10.1002/adma.202005501>.
- Arroyo-de Dompablo ME, Ponrouch A, Johansson P, Rosa Palacin M, Achievements, challenges, and prospects of calcium batteries, Chemical Reviews 120 (2020) 6331-6357. <https://doi.org/10.1021/acs.chemrev.9b00339>.
- Yu X, Boyer MJ, Hwang GS, Manthiram A, Toward a reversible calcium-sulfur battery with a lithium-ion

- mediation approach, *Advanced Energy Materials* 9 (2019) 1803794. <https://doi.org/10.1002/aenm.201803794>.
20. Reinsberg Ph, Bondue ChJ, Baltruschat H, Calcium-oxygen batteries as a promising alternative to sodium-oxygen batteries, *The J. Phys. Chem. C*. 120 (2016) 22179-22185. <https://doi.org/10.1021/acs.jpcc.6b06674>.
 21. Bhattacharyya R, El-Emam RS, Khalid F, Multi-criteria analysis for screening of reversible metal hydrides in hydrogen gas storage and high-pressure delivery applications, *Int. J. Hydrogen Energy* 47 (2022) 19718-19731. <https://doi.org/10.1016/j.ijhydene.2021.12.168>.
 22. Ropp RC. *Encyclopedia of the alkaline earth compounds*. Elsevier B.V.: Oxford; 2012. 1190 p. <https://doi.org/10.1016/C2012-0-00777-6>.
 23. Kotsar ML, Talanov AA, Thermodynamics of high-purity calcium production, *Rus. J. Inorg. Chem.* 61 (2016) 344-350. <https://doi.org/10.1134/S003602361603013X>.
 24. Tarasov VP, Kropachev AN, Kulifeev VK, Overview of contemporary scientific research results in calcium metallurgy, *Tsvetnye Metally* 2015(9) (2015) 73-77. <https://doi.org/10.17580/tsm.2015.09.12>.
 25. Polat BT, Öner İE, Kan S, Benzeşik K, Yücel O, Fused calcium aluminate production from aluminum white dross residue, *J. Sustainable Metallurgy* 8(2) (2022) 851-862. <https://doi.org/10.1007/s40831-022-00532-w>.
 26. Kulifeev VK, Kropachev AN, Tarasov VP, Thermodynamic investigations and substantiation of the aluminothermic fabrication method of calcium, *Rus. J. Non-Ferrous Metals* 57(1) (2016) 7-13. <https://doi.org/10.3103/S1067821216010090>.
 27. El-Sadek MH, El-Barawy K, Morsi IM, Production of calcium metal by aluminothermic reduction of Egyptian limestone ore, *Canadian Metallurgical Quarterly* 58(2) (2018) 1-10. <https://doi.org/10.1080/00084433.2018.1544343>.
 28. Taşyürek KC, Bugdayci M, Yucel O, Reduction conditions of metallic calcium from magnesium production residues, *Metals* 8(6) (2018) 383. <https://doi.org/10.3390/met8060383>.
 29. Davy H. Electro-chemical researches on the decomposition of the earths; with observations on the metals obtained from the alkaline earths, and on the amalgam procured from ammonia. *Philosophical Trans. Royal Society of London* 98 (1808) 333-370. <https://doi.org/10.1098/rstl.1808.0023>.
 30. Zutter H, Redlich C, Verfahren der elektrolytischen darstellung von erdalkalimetallen, namentlich von calcium auf feuerflüssigem wege in kompakter, insbesondere stangenform, Patent DE155433, published 10.05.1903, Deutsch.
 31. Mikulinsky AS, Continuous vacuum electric furnace, Soviet Union patent SU154966, 1960 May 16.
 32. Threadgill WD, Preparation of metallic calcium be electrolysis of calcium oxide dissolved in molten calcium chloride, *J. Electrochem. Soc.* 111 (1964) 1408-1411. <https://doi.org/10.1149/1.2426015>
 33. Talanov AA, Kotsar ML, Ilyenko EV, Kiverin VL et al. Analysis of the technical and economic indicators of modern calcium production, *Tsvetnye Metally* 2013(1) (2013) 57-60.
 34. Claquesin J, Gibilaro M, Massot L, Lemoine O et al, Thermodynamic properties of CaCl₂-CaF₂-CaO system: Phase diagram investigation, *Materials Sciences and Applications* 12 (2021) 139-151. <https://doi.org/10.4236/msa.2021.124009>.
 35. Tomkute V, Solheim A, Olsen E, CO₂ capture by CaO in molten CaF₂-CaCl₂: optimization of the process and cyclability of CO₂ capture, *Energy & Fuel* 28 (2014) 5345-5353. <https://doi.org/10.1021/EF5010896>.
 36. Boghosian S, Godo A, Mediaas H, Ravlo W et al. Oxide complexes in alkale – alkaline – earth chloride melts // *Acta Chem. Scand* 45 (1991) 145-157. <https://doi.org/10.3891/acta.chem.scand.45-0145>.
 37. Wang Sh, Wang W, Li Sh, Cao Sh, Cathodic behavior of molten CaCl₂-CaO and CaCl₂-NaCl-CaO, *Int. J. Minerals, Metallurgy, and Materials* 17 (2010) 791-794. <https://doi.org/10.1007/s12613-010-0391-8>.
 38. Pinching GD, Bates RG. Purification of sodium chloride and potassium chloride for use in electrochemical work, and the determination of small amounts of bromide, *J. Research of the National Bureau of Standards Research* 37 (1946) RPI749. <https://doi.org/10.6028/jres.037.020>.
 39. Laitinen H, Ferguson W, Osteryoung R, Preparation of pure fused lithium chloride-potassium chloride eutectic solvent, *J. Electrochem. Soc.* 104 (1957) 516 <https://doi.org/10.1149/1.2428639>.
 40. Kurley JM, Halstenberg PhW, Mc Alister A, Raiman S, Dai Sh, Mayes RT, Enabling chloride salts for thermal energy storage: implications of salt purity, *RSC Advances* 9 (2019) 25602. <https://doi.org/10.1039/c9ra03133b>.
 41. Shishkin VYu, Mityayev VS. Ochistka galogenidov shchelochnykh metallov metodom zonnoy plavki [Purification of alkali metal halides by zone melting], *Proc. Academy of Sciences of the USSR. Inorganic materials* 18(11) (1982) 1917-1918. Russian.
 42. Nikolaev AYu, Mullabaev AR, Suzdaltsev AV, Kovrov VA et al., Purification of alkali-metal chlorides by zone recrystallization for the use in pyrochemical processing of spent nuclear fuel, *Atomic Energy* 131(4) (2022) 195-201. <https://doi.org/10.1007/s10512-022-00865-5>.

43. Smirnov M, Korzun I, Oleynikova V, Hydrolysis of molten alkali chlorides, bromides and iodides, *Electrochim. Acta* 33 (1988) 781-788. [https://doi.org/10.1016/S0013-4686\(98\)80007-8](https://doi.org/10.1016/S0013-4686(98)80007-8).
44. Swider S, Lam S, Motakef S, Donohoe E et al. Impurity segregation in zone-refined precursors for crystalline halide scintillators, *Nuclear Instruments and Methods in Physics Research A* 784 (2015) 5-8. <https://doi.org/10.1016/j.nima.2014.11.048>.
45. Mukherjee A, Kumaresan R, Ghosh S, Redox behaviour of CaCl_2 melts in presence of moisture as impurity. Part I: Cyclic voltammetry, *J. Electroanal. Chem.* 902 (2021) 115778. <https://doi.org/10.1016/j.jelechem.2021.115778>.
46. Yin H, Gao L, Zhu H., Mao X et al. On the development of metallic inert anode for molten CaCl_2 -CaO system, *Electrochim. Acta* 56 (2011) 3296-3302. <https://doi.org/10.1016/j.electacta.2011.01.026>.
47. Threadgill WD, The calcium chloride - calcium oxide fused salt electrolytic system: solubilities, metal contents, and freezing point, *J. Electrochem. Soc.* 112(6) (1965) 632-633. <https://doi.org/10.1149/1.2423626>
48. Wenz DA, Jonson I, Wolson RD, CaCl_2 -rich region of the CaCl_2 - CaF_2 -CaO system, *J. Chem. Eng. Data* 14 (1969) 250-252. <https://doi.org/10.1021/JE60041A027>.
49. Wang S, Zhang F, Lin X, Zhang L, CaO solubility and activity coefficient in molten salt CaCl_2 -X (X=O, NaCl, KCl, SrCl_2 , BaCl_2 and LiCl), *Thermochim. Acta* 470 (2008) 105-107. <https://doi.org/10.1016/j.tca.2008.02.007>.
50. Antonov BD, Stepanov VP, Kulik NP, Formation of colloidal particles in melts of the CaCl_2 -CaO system. High-temperature X-ray diffraction study // *Colloid Journal of the Russian Academy of Sciences* 60(4) (1998) 442-445.
51. Perry GS, Macdonald LG, Role of CaCl_2 in the reduction of PuO_2 , *J. Nucl. Materials* 130 (1985) 234-241. [https://doi.org/10.1016/0022-3115\(85\)90312-5](https://doi.org/10.1016/0022-3115(85)90312-5).
52. Zinchenko VF, Timukhin EV, Pavlinchuk SA, Nechiporenko AV et al., Basicity-acidity and solubility of metal fluorides and oxides in salt melts, *Rus. J. Electrochem.* 48(10) (2012) 995-999. <https://doi.org/10.1134/S102319351210014X>.
53. Solodkova MV, Zhuravlev VI, Volkovich AV, Solubility of calcium, strontium and barium oxides in chloride and chloride-fluoride melts, *ChemChemTech* 52(6) (2009) 8-12.
54. Janz GJ, Thermodynamic and transport properties for molten salts, American Chemical Society and the American Institute of Physics: Michigan; 1988. 309 p. ISBN 978-0883185872.
55. Dworkin AS, Bronstein HR, Bredig MA, Ionic melts as solvent for electronic conductors // *Discuss. Faraday Society* 32 (1961) 188-196. <https://doi.org/10.1039/DF9613200188>.
56. Axler KM, De Poorter GL, Solubility studies of the Ca-CaO-CaCl₂ system, *Materials Science Forum* 73-75 (1991) 19-24. <https://doi.org/10.4028/www.scientific.net/MSF.73-75-19>.
57. Shaw S, Watson R, Solubility of calcium in CaCl_2 -CaO, *ECS Transactions* 16(49) (2009) 301-308. <https://doi.org/10.1149/1.3159334>.
58. Freidina EB, Fray DJ, Study of the ternary system CaCl_2 -NaCl-CaO by DSC, *Thermochim. Acta* 356 (2000) 97-100. [https://doi.org/10.1016/S0040-6031\(00\)00419-6](https://doi.org/10.1016/S0040-6031(00)00419-6).
59. Kosnyrev GT, Desyatnik VN, Kern IA, Nosonova EN, Obshchaya shchelochnost' i rastvorimost' CaO v rasplavakh CaCl_2 -KCl-NaCl [Total alkalinity and solubility of CaO in CaCl_2 -KCl-NaCl melts], *Rasplavy* 1990(2) (1990) 120-123. Russian.
60. Cherginets VL, Khimiya oksosoyedineniy v ionnykh rasplavakh [Chemistry of oxo compounds in ionic melts]. National Academy of Sciences of Ukraine: Kharkov; 2004. 279 p. Russian. ISBN 966-02-3244-6.
61. Volkovich AV, Ermakov DS, Zhuravlev VI, Kvantovokhimicheskoye modelirovaniye galogenidnykh i oksidnokalogenidnykh kompleksnykh ionov kal'tsiya [Quantum-chemical modeling of halide and oxide-halide complex calcium ions], *Rasplavy* 1999(1) (1999) 49-54. Russian.
62. Grjotheim K, Holm JL, Lillebuen B, Oye HA, Surface tension of liquid binary and ternary chloride mixtures, *Acta Chem. Scand.* 26 (1972) 2050-2062. <https://doi.org/10.3891/acta.chem.scand.26-2050>.
63. Brautigam G, Emons HH, Dichten und volum in geschmolzener salzmischungen aus erdalkalimetallchlorid und alkalimetallchlorid, *Z. Anorg. Allg. Chem.* 394 (1972) 271-278. <https://doi.org/10.1002/zaac.19723940309>.
64. Grjotheim K, Holm JL, Lillebuen B, Oye HA, Densities and excess molar volumes of binary and ternary melts of MgCl_2 , CaCl_2 and AlkCl, *Trans. Faraday Soc.* 67 (1971) 640-648. <https://doi.org/10.1039/TF9716700640>.
65. Dumas D, Fjeld B, Grjotheim K, Oye HA, Viscosities of some binary mixtures between MgCl_2 , CaCl_2 and AlkCl, *Acta Chem. Scand.* 27 (1973) 319-328. <https://doi.org/10.3891/acta.chem.scand.27-0319>.
66. Tseng M, Ricci L, Tao M, Multi-potential electropurification of a reusable CaCl_2 - CaF_2 eutectic salt for solar-grade Si electrorefining, *Separation and Purification Technology* 274 (2021) 119030. <https://doi.org/10.1016/j.seppur.2021.119030>.
67. Tago Y, Endo Y, Morita K, Tsukihashi F et al, The activity of CaO in the CaO-CaCl₂ and CaO-CaCl₂-CaF₂ systems. *ISIJ International*, 35(2) (1995) 127-131. <https://doi.org/10.2355/isijinternational.35.127>.

69. Olsen E, Hansen M, Nygård HS, Hydrolysis of molten $\text{CaCl}_2\text{-CaF}_2$ with additions of CaO , *AIMS Energy* 5(6) (2017) 873-886. <https://doi.org/10.3934/energy.2017.6.873>.
70. Davy H, The Bakerian Lecture, on some chemical agencies of electricity, *Philosophical Trans. Royal Society of London* 97 (1807) 1-57. <https://doi.org/10.1098/rstl.1807.0001>.
71. Delimarsky YuK, *Elektrokhimiya ionnykh rasplavov* [Electrochemistry of ionic melts], Metallurgy: Moscow; 1978. 248 p. Russian.
72. Guntz A, Benoit F, Sur les sous - sels alcalino - terreux, *Bull. Soc. Chim. France* 35 (1924) 709-728.
73. Peterson DT, Hinkebein JA, Equilibria in the reaction of barium with calcium chloride, *J. Phys. Chem.* 63(9) (1959) 1360-1363. <https://doi.org/10.1021/J150579A004>.
74. Emons HH, Grothe W, Hellmold P, Zur frage der existenz von erdalkalimetallsubhalogeniden, *Z. Anorg. Allgem. Chem.* 323(3-4) (1963) 114-125. <https://doi.org/10.1002/zaac.19633230304>. Deutsch.
75. Cubicciotti DD, Thurmond CD, Metal-salt interactions at high temperatures: solubilities of some alkaline earth metals in their halides, *J. Amer. Chem. Soc.* 71 (1949) 2149-2153. <https://doi.org/10.1021/JA01174A067>.
76. Lichter BD, Bredig MA, Solid and liquid phase miscibility of calcium metal and calcium fluoride, *J. Electrochem. Soc.* 112(5) (1965) 506-510. <https://doi.org/10.1149/1.2423584>.
77. Sharma RA, The solubilities of calcium in liquid calcium chloride in equilibrium with calcium-copper alloys, *J. Phys. Chem* 74 (1970) 3896-3900. <https://doi.org/10.1021/J100716A009>.
78. Dosaj V, Aksaranan Ch, Morris DR, Thermodynamic properties of the calcium + calcium chloride system measured by an electrochemical technique, *J. Chem. Soc., Faraday Trans.* 71 (1975) 1083-1098. <https://doi.org/10.1039/F19757101083>.
79. Blender M (ed.), *Molten salts chemistry*, Interscience Publishers: New York; 1964. p. 367-425. <https://doi.org/10.2172/4658668>.
80. Dworkin AS, Bronstein HR, Bredig MA, The electrical conductivity of solutions of metals in their molten halides. VIII. Alkaline earth metal systems, *J. Phys. Chem.* 70 (1966) 2384-2388. <https://doi.org/10.1021/j100879a048>.
81. Lovering D (ed.), *Molten Salt Technology*, Plenum Press: London-New York; 1982. p. 153-183. https://doi.org/10.1007/978-1-4757-1724-2_7.
82. Sychev AG, Nikulin NA, Zaikov YuP, Ivanovskii LE, *Issledovaniye katodnykh protsessov v rasplave khlorida kal'tsiya* [Investigation of cathode processes in molten calcium chloride], *Rasplavy* 1992(6) (1992) 32-37. Russian.
83. Kovalevskii RA. *Electrode processes at the indifferent electrode in dilute solutions of alkali and alkaline earth metals in their molten chlorides* [dissertation]. Yekaterinburg (Russia): Institute of High Temperature Electrochemistry UB RAS. 1992.
84. Zobnin EV, *Technology of electrolytic production of copper-calcium alloy* [dissertation]. Yekaterinburg (Russia): Institute of High Temperature Electrochemistry UB RAS. 1998.
85. Chen GZ, Fray DJ, Farthing TW, Direct electrochemical reduction of titanium dioxide to titanium in molten calcium chloride, *Nature* 407 (2000) 361-363. <https://doi.org/10.1038/35030069>.
86. Sri Maha Vishnu D, Sanil N, Shakila L, Panneerselvam G et al., A study of the reaction pathways during electrochemical reduction of dense Nb_2O_5 pellets in molten CaCl_2 medium, *Electrochimica Acta* 100 (2013) 51-62. <https://doi.org/10.1016/j.electacta.2013.03.135>.
87. Wang D, Jin X, Chen GZ, Solid state reactions: an electrochemical approach in molten salts, *Annual Reports Section C* 104 (2008) 189-234. <https://doi.org/10.1039/B703904M>.
88. Alexander DTL, Schwandt C, Fray DJ, The electro-deoxidation of dense titanium dioxide precursors in molten calcium chloride giving a new reaction pathway, *Electrochim. Acta*, 56 (2011) 3286-3295. <https://doi.org/10.1016/j.electacta.2011.01.027>.
89. Yan XY, Fray DJ, Electrochemical studies on reduction of solid Nb_2O_5 in molten $\text{CaCl}_2\text{-NaCl}$ eutectic II. Cathodic processes in electrodeoxidation of solid Nb_2O_5 , *J. Electrochem. Soc.* 152 (2005) E308-E318. <https://doi.org/10.1149/1.2006567>.
90. Yan XY, Fray DJ, Direct electrolytic reduction of solid alumina using molten calcium chloride-alkali chloride electrolytes, *J. Appl. Electrochem.* 39 (2009) 1349-1360. <https://doi.org/10.1007/S10800-009-9808-3>.
91. Peng J, Li G, Chen H, Wang D, Jin X, Chen GZ, Cyclic voltammetry of ZrO_2 powder in the metallic cavity electrode in molten CaCl_2 , *J. Electrochem. Soc.* 157 (2010) F1-F9. <https://doi.org/10.1149/1.3244568>.
92. Talanov AA, Kotsar ML, Konshin RS, Kiverin VL, Calcium distillation processes in modernized equipment with increased productivity, *Tsvetnye Metally* 2016(2) (2016) 57-61. <https://doi.org/10.17580/tsm.2016.02.09>
93. Ermakov DS, *Electrochemical behavior of calcium in potassium-contained oxide-chloride melts* [dissertation], Novomoskovsk (Russia), Mendeleev University of Chemical Technology. 1999.
94. Zaikov YuP, Kozhevnikov V., Ivanovsky LE, *Vzaimodeystviye kal'tsiya i medno-kal'tsiyevykh splavov s rasplavom khlorida kal'tsiya* [Interaction of calcium and

- copper-calcium alloys with molten calcium chloride], *Rasplavy* 1989(3) (1989) 92-94. Russian.
95. Zaikov YuP, Sychev AG, Zobnin EV, Katodnye protsessy v rasplave khlorida kal'tsiya [Cathodic processes in calcium chloride melt], *Rasplavy* 1996(4) (1996) 17-23. Russian.
 96. Barbin NM, Nekrasov VN, Ivanovsky LE, Issledovaniye ravnovesiya reaktsii $\text{CaO} + \text{CO}_2 \leftrightarrow \text{CaCO}_3$ v khlordnykh i khlordno-ftoridnykh rasplavakh [Study of the equilibrium of the reaction $\text{CaO} + \text{CO}_2 \leftrightarrow \text{CaCO}_3$ in chloride and chloride-fluoride melts], *Rasplavy* 1987(2) (1987) 108-111. Russian.
 97. Delimarsky YuK, Grishchenko VF, Garodysky AV, Study of reactions occurring during the electrolysis of molten carbonates, *Ukr. Chem. Journal* 31(1) (1965) 32-37.
 98. Lebedev VA, Salnikov VI, Tarabaev MV, Sizikov IA et al., Kinetics and mechanism of the processes occurring at graphite anode in a $\text{CaO}-\text{CaCl}_2$ melt, *Rus. J. Applied Chem.* 80 (2007) 1498-1502. <https://doi.org/10.1134/S107042720709011X>.
 99. Sakamura Y, Iizuka M, Applicability of nickel ferrite anode to electrolytic reduction of metal oxides in $\text{LiCl}-\text{Li}_2\text{O}$ melt at 923 K, *Electrochim. Acta* 189 (2016) 74-82. <https://doi.org/10.1016/j.electacta.2015.12.086>.
 100. Otake K, Kinoshita H, Kikuchi T, Suzuki RO, CO_2 gas decomposition to carbon by electro-reduction in molten salts, *Electrochim. Acta* 100 (2013) 293-299. <http://doi.org/10.1016/j.electacta.2013.02.076>.
 101. Li L, Shi Zh, Gao B, Xu J et al. Electrochemical behavior of carbonate ion in the $\text{LiF}-\text{NaF}-\text{Li}_2\text{CO}_3$ system, *Electrochemistry* 82 (2014) 1072-1077. <https://doi.org/10.5796/electrochemistry.82.1072>.
 102. Zotin IV, Zaikov YuP, Ivanovsky LE, Rastvorimost' nitrida kal'tsiya v rasplavakh CaCl_2 i CaCl_2-KCl [Solubility of calcium nitride in CaCl_2 and CaCl_2-KCl melts], *Rasplavy* 1989(1) (1989) 102-103. Russian.
 103. Zotin IV, Zaikov YuP, Ivanovsky LE, Issledovaniye rasplavov khlorida-nitrida kal'tsiya metodom EDS [Study of calcium chloride-nitride melts by the EMF method], *Rasplavy* 1989(6) (1989) 114-117. Russian.
 104. Bonomi A, Hadat M, Breda F, Electrochemical studies on ionic nitride solution in molten salts, *J. Electrochem. Soc.* 126 (1979) 248-251. <https://doi.org/10.1149/1.2129013>.
 105. Zaikov YuP, Molostov OG, Batukhtin VP, Ivanovsky LE, Germetichnyy elektrolizer dlya polucheniya medno-kal'tsiyevogo splava [Hermetic electrolytic cell for obtaining copper-calcium alloy], *Rasplavy* 1999(3) (1999) 72-79. Russian.
 106. Zaikov YuP, Molostov OG, Batukhtin VP, Ivanovsky LE, Primeneniye impul'snogo toka pri proizvodstve medno-kal'tsiyevogo splava elektrolizom rasplavov [The use of pulsed current in the production of a copper-calcium alloy by electrolysis of melts], *Rasplavy* 2000(1) (2000) 43-48.
 107. Kondo H, Asaki Z, Kond Y, Hydrolisic of fused calcium chloride of high temperature, *Metall. Mat. Trans. B* 9 (1978) 477-483. <https://doi.org/10.1007/BF02654424>.
 108. Straka M, Lisý F, Szatmáry L. Electrodeposition of uranium by pulse electrolysis in molten fluoride salts. *Molten salts chemistry and technology*, (2014) 467-474. <https://doi.org/10.1002/9781118448847.ch6h>.
 109. Ueda M, Tsuchiya Sh, Ohtsuka T, Electrodeposition of Bi-Sb-Te alloys by pulse electrolysis in $\text{AlCl}_3-\text{NaCl}-\text{KCl}$ molten salt, *Electrochemistry* 77 (2009) 659-662. <https://doi.org/10.5796/electrochemistry.77.659>.
 110. Kireev SYu, Intensification of processes of electrodeposition of metals by use of various modes of pulse electrolysis, *Inorganic Materials: Applied Research* 8 (2017) 203-210. <https://doi.org/10.1134/S2075113317020095>.
 111. Suzuki RO, Teranuma K, Ono K, Calciothermic reduction of titanium oxide in molten CaCl_2 , *Metall. Mat. Trans. B* 34 (2003) 287-295. <https://doi.org/10.1007/S11663-003-0073-2>.
 112. Song Yu, Dou Zh, Zhang T, Liu Y, Research progress on the extractive metallurgy of titanium and its alloys, *Mineral Processing and Extractive Metallurgy Review* 42 (2021) 535-551. <https://doi.org/10.1080/08827508.2020.1793145>.
 113. Sharma RA, Seefurth RN, Metallothermic reduction of Nd_2O_3 with Ca in $\text{CaCl}_2-\text{NaCl}$ melts, *J. Electrochem. Soc.* 135 (1988) 66-71. <https://doi.org/10.1149/1.2095591>.
 114. Fischbach H Thermodynamic data for liquid $\text{Ca}-\text{CaF}_2$ and $\text{Ca}-\text{CaCl}_2$ slags *Steel Research* 56(7) (1985) 365-368. <https://doi.org/10.1002/srin.198500649>.
 115. Okabe TH, Nakamura M, Oishi T, Ono K, Electrochemical deoxidation of titanium, *Metall. Mat. Trans. B* 24 (1993) 449-455. <https://doi.org/10.1007/BF02666427>.
 116. Han S, Lee Y, Park J, Choi G et al., Deoxidation thermodynamics of β -titanium by $\text{Ca}-\text{CaCl}_2$ and $\text{Ca}-\text{CaF}_2$ fluxes, *Mater. Trans.* 50 (2009) 215-218. <https://doi.org/10.2320/matertrans.mrp2008284>.
 117. Fray DJ, Farting TW, Chen GZ. Removal of oxygen from metal oxides and solid solutions by electrolysis in a fused salt. Great Britain patent GB9812169, 1998 June 5.
 118. Shurov NI, Khramov AP, Zaikov YuP, Kovrov VA et al., Reduction mechanism of oxides in calcium chloride melts, *Rus. J. Non-ferrous Metals* 56 (2015) 267-271. <https://doi.org/10.3103/S1067821215030207>.
 119. Suzdaltsev AV, Khramov AP, Zaikov YuP, Pankratov AA et al., Reduction of the solid Al_2O_3 at the electrolysis of the

- CaCl₂ based melt, *J. Electrochem. Soc.* 164(8) (2017) H5183-H5188. <https://doi.org/10.1149/2.0291708jes>.
120. Smirnov MV, Elektrodnyye protsessy v rasplavlennykh khloridakh [Electrode processes in molten chlorides], Nauka: Moscow; 1976. 280 p.
 121. Baraboshkin AN, Elektrokristallizatsiya metallov iz rasplavlennykh soley [Electrocrystallization of metals from molten salts], Nauka: Moscow: 1976, pp. 99-106.
 122. Nikolaev AYu, Pavlenko OB, Suzdaltsev AV, Zaikov YuP et al., Reduction of ZrO₂ during the SNF pyroprocessing, *J. Electrochem. Soc.* 168(3) (2021) 036506. <https://doi.org/10.1149/1945-7111/abe8be>.
 123. Weng W, Wang M, Gong X, Wang Zh et al., Direct electro-deposition of metallic chromium from K₂CrO₄ in the equimolar CaCl₂-KCl molten salt and its reduction mechanism, *Electrochimica Acta* 212 (2016) 162-170. <https://doi.org/10.1016/j.electacta.2016.06.142>.
 124. Li H, Jia L, Cao W, Liang J et al., The electrochemical reduction mechanism of Fe₃O₄ in NaCl-CaCl₂ melts, *Int. J. Chem. Reactor Eng.* 19(1) (2021) 43-52. <https://doi.org/10.1515/ijcre-2020-0179>.
 125. Li H, Fu Y, Liang J, Li C, Electrochemical mechanism of recovery of nickel metal from waste lithium ion batteries by molten salt electrolysis, *Materials* 14 (2021) 6875. <https://doi.org/10.3390/ma14226875>.
 126. Li L, Liu X, Wang S, Electrochemistry of Fe(III) in molten salt CaCl₂-KF and CaCl₂-CaF₂-KF. *Energy Technology* 2014, 135-140. <https://doi.org/10.1002/9781118888735.ch17>.
 127. Gaune-Escard M, Seddon KR (eds), *Molten Salts and Ionic Liquids: Never the Twain?* Wiley & Sons Ltd: London; 2012. 464 p. ISBN: 978-0-470-94777-7.
 128. Mohamedi M, Borresen B, Haarberg GM, Tunold R, Anodic behavior of carbon electrodes in CaO-CaCl₂ melts at 1123 K, *J. Electrochem. Soc.* 146(4) (1999) 1472-1477. <https://doi.org/10.1149/1.1391789>.
 129. Lebedev VA, Salnikov VI., Tarabaev MV, Sizikov IA et al., Kinetics and mechanism of the processes occurring at graphite anode in a CaO-CaCl₂ melt, *Rus. J. Applied Chem.* 80 (2007) 1498-1502. <https://doi.org/10.1134/S107042720709011X>.
 130. Dubovtsev AB, Zaikov YuP, Batukhtin VP, Ivanovsky LE, Povedeniye oksidnykh anodov pri elektrolize khlordnykh rasplavov. 1. Vzaimodeystviye oksidnykh elektrodov s rasplavom [Behavior of oxide anodes during the electrolysis of chloride melts. 1. Interaction of oxide electrodes with melt], *Rasplavy* 1992(1) (1992) 35-40. Russian.
 131. Dubovtsev AB, Zaikov YuP, Murygin TV, Ivanovsky LE, Povedeniye oksidnykh anodov pri elektrolize khlordnykh rasplavov. 2. Issledovaniye anodnogo protsessa na keramicheskoy elektrode v rasplave CaCl₂-CaO [Behavior of oxide anodes during the electrolysis of chloride melts. 2. Study of the anodic process on a ceramic electrode in a CaCl₂-CaO melt], *Rasplavy* 1992(1) (1992) 41-48. Russian.
 132. Zaikov YuP, Khramov AP, Frolov AV, Ivanovskiy LE et al., Investigation of interaction of oxygen with halide melt, *J. High Temperature Material Processes* 6(1) (2002) 1-4. <https://doi.org/10.1615/HighTempMatProc.v6.i1.80>.
 133. Jiao Sh, Fray DJ, Development of an inert anode for electrowinning in calcium chloride-calcium oxide melts, *Metall. Mat. Trans. B* 41 (2010) 74-79. <https://doi.org/10.1007/S11663-009-9281-8>.
 134. Ge J, Zou X, Almassi S, Ji L et al. Electrochemical production of Si without generation of CO₂ based on the use of a dimensionally stable anode in molten CaCl₂, *Angewandte Chemie* 131 (2019) 16369-16374. <https://doi.org/10.1002/ange.201905991>.
 135. Hu L, Song Y, Ge J, Jiao Sh et al., Electrochemical metallurgy in CaCl₂-CaO melts on the basis of TiO₂-RuO₂ inert anode, *J. Electrochem. Soc.* 163(3) (2016) E33-E38. <https://doi.org/10.1149/2.0131603jes>.
 136. Zaikov YuP, Batukhtin VP, Suzdaltsev AV, Current efficiency during the electrorefining of copper-calcium alloy in molten CaCl₂, *Nonferrous Metals* 2014(1) (2014) 30-32.
 137. Zaikov YuP, Batukhtin VP, Shurov NI, Ivanovskii LE et al., Calcium production by the electrolysis of molten CaCl₂-Part I. Interaction of calcium and copper-calcium alloy with electrolyte, *Metall. Mat. Trans. B* 45 (2014) 961-967. <https://doi.org/10.1007/s11663-013-9990-x>.
 138. Zaikov YuP, Shurov NI, Batukhtin VP, Molostov OG, Calcium production by the electrolysis of molten CaCl₂-Part II. Development of the electrolysis devices and process technology approval, *Metall. Mat. Trans. B* 45 (2014) 968-974. <https://doi.org/10.1007/s11663-013-9991-9>.
 139. Ivanovsky LE, Zaikov YuP, Kazantsev GF, Sychev AG et al., Electrolyzer for obtaining alloys in molten salts, Soviet Union patent SU1254769, 1983 Dec 15.
 140. Molostov OG, Kosenko GD, Ogloblin VV, Ivanovsky LE et al. Electrolyzer for three-layer electrolytic refining of metals, Soviet Union patent SU1356532, 1986 Apr 9.
 141. Ivanovsky LE, Zaikov YuP, Sychev AG, Batukhtin VP et al. Electrolyzer, Soviet Union patent SU1840842, 1986 Apr 16.
 142. Belozeroval NV, Budanov RE, Zhurin IS, Zobnin EV et al. Electrolyzer for obtaining alkaline earth metals from melts, Russian Federation patent RU2339744, 2006 Sept 28.
 143. Ono Yu, Yamaguchi M, Molten salt electrolyzer for reducing metal, method for electrolyzing the same, and the process for producing refractory metal with using

- reducing metal, United States patent US2009152104, 2006 June 21.
144. Li J, 30kA liquid state cathode calcium metal electrolytic bath, China patent CN103911630, 2014 July 09.
145. Bakumenko VG, Bulychev PI, Baryshnikov SS, Evdokimov AA et al. Electrolyzer for obtaining alloys of alkaline earth metals, Russian Federation patent RU2234556, 2003 Jan. 4.
146. Vostryakov AA, Bykov AS, Lepinskikh BM, Corrosion of steel in Cu–Ca alloys, Protection of metals 1981(4) (1981) 463-465.