

## Miguel Ek Lopes and Nelson Campos Ramalho

# The Bright Side of the Dark Side: Covert Politics as an Alternative to the Negative Impacts of Coercive Change

This study examines practitioners as individual actors by focusing on a general manager's individual account. With a two-week episode of political maneuvering as a starting point, the case shows how skilful strategizing on the part of the general manager is at the origin of significant organizational change. Specifically, the paper has three purposes. First, to offer insights to practitioners and scholars regarding how powerful managers purposefully seek to influence organizational context in a non-disclosed fashion. Second, to illustrate how single case microstudies open a route to understanding events that would otherwise be unattainable. The third, and most important, is to apply organizational politics concepts to characterize managerial covert political action in the implementation of a deliberate strategy. Specifically, emphasis is put on how contextual characteristics relate to political action. How they constrain and enable politics, and facilitate the use and maintenance of concealed motives.

**Key words:** managerial action, politics, strategy-as-practice.

### Introduction

This single case takes a general manager's point-of-view. A degrading economy and conflicting interests among participants regarding changes required to implement strategy are deemed to have motivated the emergence of politics. Following Drory and Room [1990], organizational politics is viewed to arise when goals are sought via informal influence in the presence of potential conflict. Using a political perspective, organizational context changes promoted via a mix of formal and informal influence activities are explored to characterize how the general manager's political action relates to organizational context in order to effect change.

The paper follows with a discussion of organizational context, highlighting its role in strategy process literature and the importance of informality for its study. It then, fol-

lows a presentation of the research context and adopted methodology as well as the case background and a narrative of the focal episode. Next, comes the analysis and interpretation of events, focusing on the role of politics, particularly in how the case informs us about the political activity of the manager. Finally, a discussion of the contribution and limitations of the findings ends the paper.

## Strategy and Organizational Context

Managers shape strategy by influencing the organizational context. However, research on organizational context management has focused on formal aspects [Ghoshal and Bartlett, 1994; Jarzabkowski, 2008]. Extant research has also related, to some extent, informal elements of the organizational context and managerial action. Ghoshal and Bartlett [1994] conceptualize managerial action as simultaneously influencing and being shaped by the organizational context. At the individual level, Jarzabkowski [2008] focused on patterns of interaction and their relation with the degree of institutionalization. Therefore, focus has rested either on non-contextual outcomes or on interaction patterns. As a consequence, the organizational context is generally disregarded as a locus and focus of managerial action, especially in terms of informal influence or politics.

Bower [1970] recognized formal aspects (structural context) and informal aspects (situational context). He underlined informal aspects consisting of social, individual, and historical factors as critical for the management of any concrete situation. However, he dismissed them as non-generalizable. Nonetheless, previous and ulterior researchers have argued for examining the role of social context and informal organization [e.g. Barnard, 1938; Floyd and Lane, 2000; Johnson et al., 2003].

Organizational context arises as the historical accumulation of individual and collective decisions and actions within the organization, which in turn shapes organizational members' actions. Miller et al. [2004] argued for considering managerial action in order to link these conditions to strategy implementation success.

The situational context has received extensive treatment in organizational literature under the headings of organizational climate or culture [e.g. Pettigrew, 1979; Schein, 1983; Reichers and Schneider, 1990], and has been identified as critical to organizational performance [Hansen and Wernerfelt, 1989]. In fact, organizational context is commonly regarded as a key determinant of the organizational ability to implement strategic decisions [Ghoshal and Bartlett, 1994]. Nevertheless, and in spite of exceptions identified above, almost all strategy research has focused on structural context [e.g. Bower, 1970; Burgelman, 1983]. The research focus on formality underplays political activity and also the embeddedness of both individual and collective in the wider social context.

Management seeks to establish purpose, and adapts structure, systems, and procedures in support of strategy. Regarding the situational context, management decisions and actions are not so straightforward. Ignoring informal aspects has been identified as a major factor leading to strategic failure [Nutt, 1999; Hrebiniak, 2006]. Many decisions and actions are also unpopular by nature, implying change that is neither effected by decree nor participation. Thus, collaborative change may be impossible or undesired [Dunphy and Stace, 1988]. In such situations managers may be compelled to use politics and coercive modes of change. But these approaches will generally impact negatively the informal context, affecting social links between actors. Employees, in Baum’s words, “become isolated and are unlikely to affiliate deeply with an organization” [1989:202].

Thus, the question arises of how a manager’s informal activities relate to the organizational context, when in coercive modes of change.

### Research Context and Methodology

This paper reports a two-week episode, taking place in a family business. This context is insightful since it tends to supply high-discretionary decision-making power to managers [Feltham et al., 2005]. The small firm, managed by a family member with strategic independence, is part of the family business group. Small firm general managers are often directly involved in implementing strategy, accumulating top and middle management roles. Case selection was serendipitous, but guided by revelatory potential [Yin, 2003]. Thus, there is theoretical interest [Eisenhardt, 1989; Eisenhardt and Graebner, 2007]. A previous research relationship is judged to have increased participant trust due to the successful experience in sharing sensitive data.

Table No. 1 – Methodological Procedure

Sequence	1st Data Collection	Event Reconstruction	2nd Data Collection	Analysis and writing-up
When	After the two week episode.	Following data collection.	Eleven months after the 1st data collection.	
Materials and procedures	General Manager memo notes, In-depth interviews (tape recorded) with: <ul style="list-style-type: none"> <li>■ General Manager</li> <li>■ Technical Director</li> <li>■ Sales Director</li> </ul>	Coding of shared/individual accounts, scheduled/unscheduled events.	In-depth interviews (tape recorded) with: <ul style="list-style-type: none"> <li>■ General Manager</li> <li>■ Sales Director</li> </ul> Conversations with other participants (field notes).	
Data validity and analytical goals	Confirmatory conversations with other participants (field notes).	Reconstruction of meeting dialogue, General description of events, Reconstruction of event timeline.	Development of short stories for: <ul style="list-style-type: none"> <li>■ General Manager</li> <li>■ Sales Director</li> </ul> Other participants’ views about the events.	

Data was collected for eleven months, allowing for the development of a broader knowledge of the firm. The researcher is thus arguably better equipped to evaluate the importance and effect of contextual factors in the unfolding of the events, because of the locally grounded understanding. Thus, validity is assured not only by the triangulation of interviews and other data sources, but also by an understanding of local culture.

Data collection was initiated immediately after the focal episode. These data supplied a dense timeline of events, a reconstruction of a meeting dialogue, field notes, and quotes from several participants, covering the two-week episode. The timeline served as a guide for ulterior data collection, supplying a well-known and previously validated event sequence. It also provided details about the order of individuals' actions and quotes that would otherwise be lost. Events were synthesized with the aid of visual mapping [Langley, 1999], which served as a useful perspectivating device. Eleven months later, new data collection took place, which allowed for the unfolding of consequences, especially those concerning the General Manager's hidden agenda.

During the second collection period, interviews were conducted with the General Manager (GM) and the Sales Director (SD). Additional interactions with other participants were summed up in field notes, edited and revised within the 24-hour period recommended by Yin [2003]. The GM was interviewed with support of the timeline, since it had been previously validated and constructed with his personal memos. The opposite was done with the SD, since he was solely dependent on his memory. This avoided the masking of individual differences regarding the meaning of events and their consequences. These differences motivated a second round of interviews.

**Table No. 2** – Interview Goals for the Second Data Collection Period

	Goals	
	First Interview	Second Interview
Sales director	<p>– <b>Not using the timeline</b> – (focused on memory)</p> <ul style="list-style-type: none"> <li>■ What is recollected?</li> <li>■ What the recollections mean and what were the consequences?</li> </ul>	<p>– <b>Using the timeline</b> – (How hidden is the hidden agenda?)</p> <ul style="list-style-type: none"> <li>■ Theorize about connections between the events.</li> </ul>
General manager	<p>– <b>Using the timeline</b> – (focused on political action)</p> <ul style="list-style-type: none"> <li>■ What was the goal of actions?</li> <li>■ What were the consequences?</li> </ul>	<p>– <b>Using the timeline</b> – (how individuals' actions impacted the flow of events)</p> <ul style="list-style-type: none"> <li>■ How events/actions are linked?</li> <li>■ How individuals impacted the flow of events?</li> </ul>

Event interpretation guided the second interview with the SD. The participant was asked to theorize about the events in order to determine if he perceived the GM's hidden goals. The GM's second interview sought to explore concepts about goals and the impact of his actions on others and on strategy.

Finalized short stories were validated next to the corresponding informant, expanding data in the GM's account, as well as the SD's interpretations of the GM's actions, motives, and their impact on organization and strategy.

## Case Background

The case firm sells industrial components, systems and services. Its GM remains the sole family representative since the group acquired the firm. A minority partner remained in the firm as Technical Director (TD).

Three years before the events, a partner network strategy was devised to market a technical product that was considered competitively important, but an economic drain. The TD had not really implemented the strategy. Results were lacking and the GM felt the strategy would not be implemented under the TD's leadership. With his father, the Holding President, he had previously confronted the TD about his general lack of performance. The TD was perceived as capable, but unwilling to perform. The situation lingered since, for the group, "people-matter." However, degrading market and firm performance created a feeling that problems had to be addressed.

Feeling the pressure, the GM decided the SD would manage the partner network. The SD had been working with a Technician in order to improve departmental coordination. Some efficiency was achieved, but the SD felt the Technician resented the increased visibility of his work. The Technician worked in a two-man team with the TD, but with the change in responsibility over strategy there would mean adjustments. It was clear that the Technician had to be sold on the idea.

For the GM, these were economic decisions that simultaneously addressed increasingly problematic culture issues. The GM's dissatisfaction with the lack of cooperation and support had grown over the years. He believed the TD's example was negative. The Technician complained several times about taking on the TD's work. Something the GM disliked greatly. Reassigning responsibility over strategy was also a way to pressure the TD.

Changes were coming. Reporting to the SD, who had been exposing him to the idea, the Technician would receive responsibility for servicing partners. A meeting was scheduled to present changes in the Technician's reporting relationship. This also pretended to signal to the Technician that his cooperation was expected.

### Focal Episode

During the meeting with the GM and the SD, the Technician accepts changes, although it is clear he is unhappy. However, the GM is committed to change "... this time, the thing was moving forward," almost willing to be coercive, "I had planned to do it in a way he wouldn't have much chance of saying no." To make things happen, changes will be communicated in the next sales meeting. The GM is aware the Technician is "... definitively not on board." The next day, the Technician speaks to the SD with the aim of scheduling a meeting, because he has information that will change the GM's mind. To assure the decision is final, the GM tells the SD to stall. The following day the Technician speaks to the TD about the problems of the change and how this makes him question his position in the company. The next day, during coffee, the TD advises the GM to treat the issue with care so as not to provoke an exit. The GM argues they "could not change company policy just because some employee is unhappy, and only if the Technician threatened to leave would I be forced to back down." From this moment on, it is clear the GM has changed his immediate goal from implementing the partner network to promoting the Technician's exit – "I distinctly planted a seed there!" An exit he believes would improve the company culture. Now the Technician "either had to change or had to leave." The GM consciously becomes more political: "I know it sounds Machiavellic, but that's it, that's my job." He asks the SD to voice concerns about the Technician's possible exit to a salesperson. The idea is to make the Technician think his exit is problematic. The GM then seeks information about reactions: "Basically, I'm looking to make sure that he is getting a certain picture." The tactics succeed, for later on the SD reports gossip about the Technician voicing discontent to colleagues. Eventually, word arrives that the Technician threatened to leave if forced to change position. At the request of the GM, the SD schedules the meeting. In it, the Technician argues against the strategy and manifests a lack of interest in the project, but "I was immovable [...] to see if he would threaten to leave." Realizing he would not voice the threat, the GM eventually asks if he is resigning. The Technician seems surprised, but mentions he doesn't want to lose unemployment benefits. The GM answers that a deal can be arranged to circumvent that. The Technician says he needs to speak with his wife, and the GM says he will arrange resignation paperwork. A meeting is scheduled in a week's time, where the exit agreement is concluded in about twenty minutes.

### Structural Changes

Considering power has a structural component [Pfeffer, 1981], we analyzed structure changes using network theory concepts [Katz et al., 2004]. Initial ties were weak in terms

of their potential to supply control and implement strategy (see Figure No. 1). The TD was not pursuing the deliberate strategy. However, the GM was depending on the technical department to implement the strategy due to the technical nature of the product. Thus, the power balance prescribed the lack of need to comply with official strategy.

Figure No. 1. Formal Ties

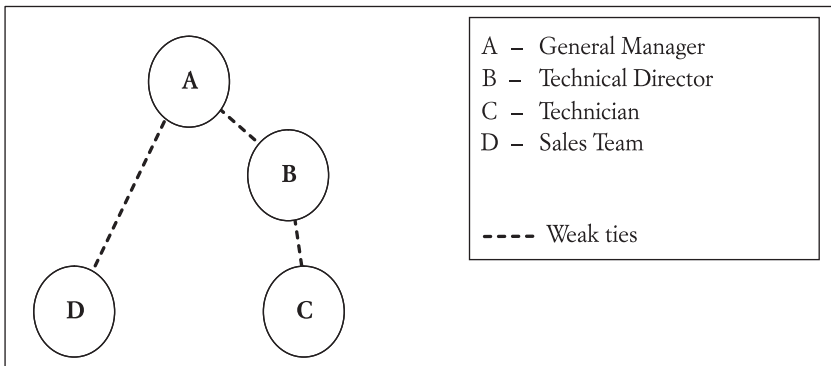

Two and a half years before the episode, the SD was placed in this position (which did not exist before). This enabled the creation of strong ties (Figure No. 2). The GM–SD formal tie, reinforced by personal trust, created the opportunity to assign the partner network strategy to the SD (this opportunity is depicted in the tie between the SD and the Technician in Figure No. 3, between nodes C and E). This favored the GM change goals, since it no longer depended on the TD to control implementation. Consequently, parties favoring the *status quo* lost power.

This change would expand operational control and cause the Technician to lose some ability to determine his activities. It would further weaken the TD’s position as well as increase his workload and performance visibility.

Figure No. 2. Formal Ties

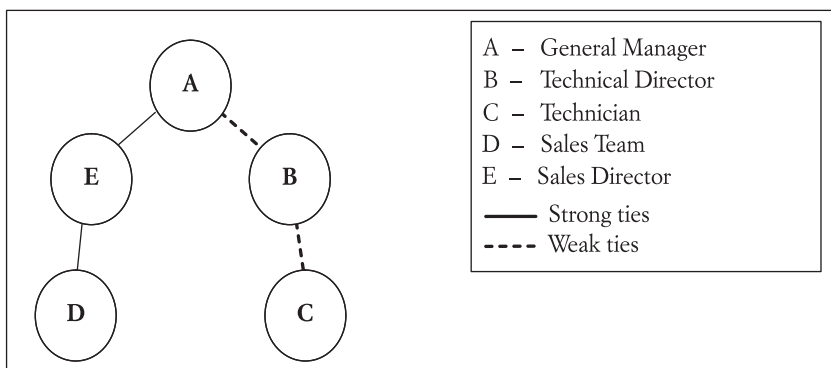
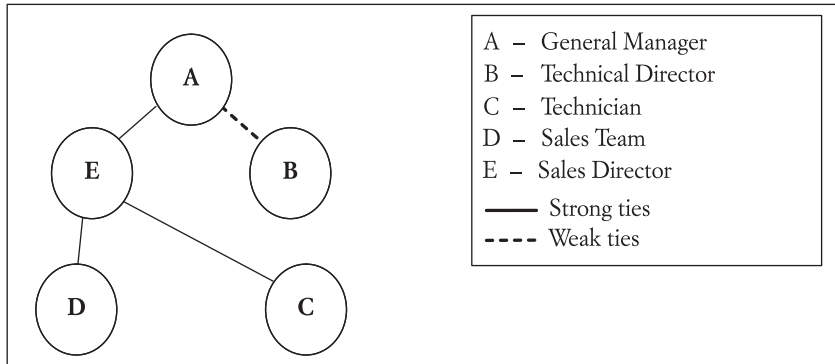
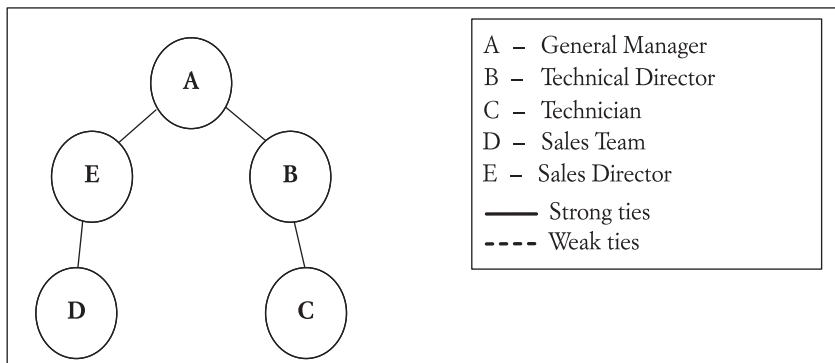

Figure No. 3. Formal Ties



The GM would also be affected since the change would make the TD less indispensable, thus his exclusion was structurally favored. When this happened, the structure was renewed back to the original configuration (Figure No. 4). However, ties became strong. Content is relevant, which is made clear by the shared perception that the new technical department is working well and implementing the official strategy.

Figure No. 4. Formal Ties



### Links to Corporate Level Constraints and Enablers

“People-centered” values, an expression of the influence of ideology [Mintzberg, 1985], constrained dealing with the TD’s lacking performance. The agenda was laden. Conflicting with the ruling ideology, it incentivized the emergence of politics due to the need to conform to espoused values. Because values are important, the GM discusses the issue with the Holding President, effectively obtaining the legitimacy to develop activities that could be perceived as contrary to business values.



## Links to Wider Context Institutions

Taken-for-granted ideas play an important role, enabling and constraining actors' activity. What "manager" means, specifically the prescriptive strength of the manager-employee relationship, enables and legitimates the GM's strategy pursuit and is instrumentalized by the isolationist tactic of forcing communication through the SD, in a context where access is usually straightforward.

Regulatory level institutions [Scott, 2008] are also significant in shaping events. Labor law determines monetary compensation to dismissed employees, but this compensation is strongly reduced if the employee resigns. Thus, context also offers an incentive for political action at the intra-organizational level as the Technician seeks to maximize his benefits and the GM, to a lesser extent, to minimize costs.

## Leveraging Unforeseen Consequences

Although targeting the TD was not the prime motivator, the GM was progressively constructing the view that the TD would have to leave. "The Technician's exit had nothing to do with the his exit. I would have to deal with that sooner or later" (GM referring to the TD).

Multiple factors concurred to create this perception, namely the worsening context, the degrading performance, and the lack of success in dealing with the TD. Positive factors also had an influence. "And we had some new team members that were good. I felt I could build a management team" (GM referring to the TD's possible exit).

It was clear for the GM that a consequence of the Technician's exit would be increased pressure on the Technical Director. This was discussed with the Holding President before the Technician's exit. Five months later, in a company downsize approved by the Holding, the TD left the company. In the following months, the technical department was blatantly renewed with existing organizational members and the strategy put in place.

## A Hidden Agenda of Context Change

Difficulties in implementing change led the GM to perceive the Technician's exit as a desired goal, "it was in the back of my head. Maybe the issue was that he was in some respects not such a good team member" (GM). In fact, the exit is equated to promoting organizational context change, "company culture had to change and the Technician was definitively from the old group" (GM). This goal is not shared, but individual. A hidden agenda the GM actively pursues.

The firm received a simple communication about an employee's exit. The SD was out of the gossip network since "they know that the Technician's going away had to do with a new role and perhaps being more controlled ... and nobody said anything to me, since I was one of the persons responsible for that decision" (SD). Common opinion seems to be that he put himself in that position by threatening to leave.

However, intentions underlying events were not that simple. For the SD, the exit was the result of the Technician's radicalization tactics. "I would not say we were taking advantage or pushing him to that solution" (SD). Quite the contrary, the SD "was a little worried with the sudden exit of the Technician. Maybe we could not make the technical department an important area of the company again."

Wider prescriptions of action legitimacy also play a part in actors' judgments of the Technician's behavior. "I would say that from the moment he said he would leave, the entire problem became different" (SD), and "He went too far by threatening to leave" (A Salesperson).

Lacking alternative interpretations, the emergent meaning fundamentally reproduces existing organizational discourse. Thus, covert political action may support the maintenance of *status quo*.

## Conclusion

The GM's activities exemplify a high-power practitioner's tacit knowledge in action, providing us with the opportunity to tentatively characterize how praxis was developed. We have found three layers that structure the political action over time:

**a) Understanding rules and values.** The ability to understand and leverage local and wider contextual rules and values is a significant characteristic. The practitioner is aware of ideological and institutional constraints, and either leverages or avoids them.

"If I say OK to the meeting, I'm somehow saying that this can move back. No, I'm increasing the pressure." (leveraging)

"Did you know he was one of the partners of the company? That's a completely different situation." (avoiding)

**b) Leveraging relationships.** By understanding contextual rules and values, the practitioner leverages relationships to obtain and distribute information as well as intra- and extra-organizational support. Without this skill any information manipulation tactics would have been impossible to pursue.

"This actually confirmed that he was unhappy and telling his colleagues that the strategy wouldn't work." (obtaining information)

"Yes, I discussed some of the possible consequences of his exit ..." (obtaining support)

c) **Hidden goals and time horizons.** Leveraging relationships facilitates the exercise of informal influence, and the pursuit of hidden goals with differing timeframes. The practitioner is aware and explores the unforeseen consequences of events. This empowers the practitioner to have a higher impact on the organizational context than simple managerial prerogative would confer.

“[...] when I realized that this situation could make him leave. [...] everything became even more important.” (demonstrates hidden motives)

“Of course the Technician’s exit would put pressure on the Technical Director. But that was OK by me,” and “More of a positive side-effect.” (hidden motives on different timeframes)

Linking the three layers requires a comprehensive perspective of their interdependencies with the context. In this sense, understanding rules and values is a first step to accomplish the leveraging of the social network in order to exercise influence. When this is sufficiently achieved one can deal effectively across time with hidden goals that leverage the unforeseen consequences of a mutating context. Successful action depends on understanding rules and values of the wider and organizational contexts. Successful action also depends on the ability to leverage social networks in order to achieve local context change. Finally, successful action requires that skilful strategizing be achieved by operating at a covert level, both concerning goals and time horizons (when in the presence of conflicting interests). The following figure depicts the theorized relations.

**Figure No. 5.** Relating Managerial Political Action to Organizational Context

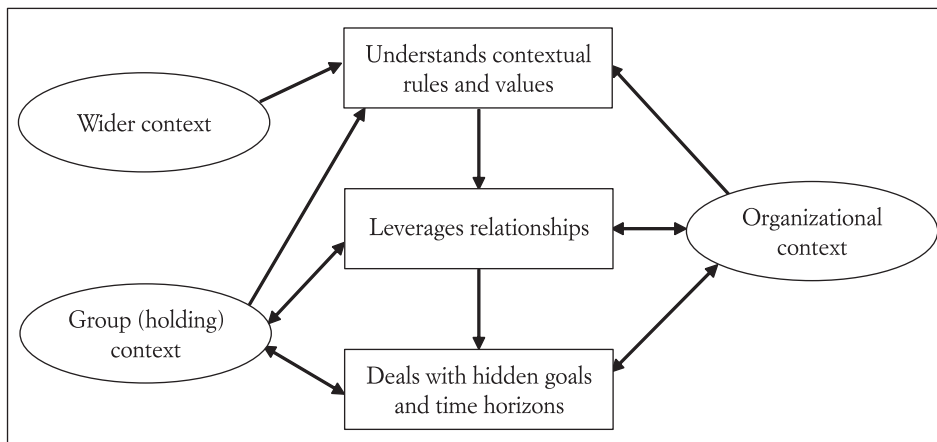

Arrows towards context (ovals) depict possible direction of influence; arrows between characteristics (squares) suggest dependence relations.

## Contributions and Limitations

The case offers insights of value to practitioners and scholars and adds to extant knowledge. It looks into the characteristics of the interaction of the manager's political action and organizational context in situations of coercive change [Dunphy and Stace, 1988]. The case suggests covert politics are a means to minimize the negative impacts associated with these types of strategies.

The case contributes to strategy-as-practice by supplying a characterization of how powerful managers may influence the organizational context. As such, it effectively captures the illusive moment of strategy emergence [Whittington, 2003]. However, the valuation of such outcomes is clearly dependent on individual perspectives.

The contextual specificity and the fact that observations are limited to a single case impose caution regarding theoretical generalization. Characteristics of covert political action are likely limited to contexts where single decision-makers have high discretionary power, such as those found in family businesses [Feltham et al., 2005]. In this setting, general managers accumulate top and middle management activities, which simplifies the empirical landscape, facilitating access to actions and intentions. Although this can enrich results it undermines the relevancy of insights regarding more complex settings. Likewise, the high-power condition may not be observed in other contexts. Further research is thus necessary.

In terms of empirical support, we have amply drawn on case material, which is believed to be illustrative. Nevertheless, individual intentions paramount to politics research remain the weakest link [Drory and Room, 1990] in spite of the efforts to validate these data. The decision to construct large, narrative type, descriptions was also based on the need to critically demonstrate how events are interrelated and to offer support to accept the data as valid [Eisenhardt, 1989; Langley, 1999]. Hopefully, this goal was achieved and the conclusions pose as self-evident.

Methodologically, this case study contributes with a political perspective that proves to be a fruitful approach for strategy-as-practice and process research, underlining the importance of context (both organizational and societal) in shaping decisions and actions as well as their impact on the organizational context. All in all, manipulation and coercive change may be labeled as vicious, and therefore, show the dark side of organizations. But politics will keep its potential to solve organizational conflict in socially accepted ways. It is definitely a dark side, but maybe not that dark.

---

## REFERENCES

- Balogun, J., Huff, A. S., and Johnson, P. (2003), "Three Responses to the Methodological Challenges of Studying Strategizing," *Journal of Management Studies*, 40, 197–224.
- Barnard, C. (1938), *The Functions of the Executive*, Cambridge, Harvard University Press – 30th Anniversary Edition.
- Baum, J. A. (1989), "Organizational Politics against Organizational Culture: A Psychoanalytic Perspective," *Human Resource Management*, 28, 191–206.
- Bower, J. L. (1970), *Managing the Resource Allocation Process*, Boston, Harvard Business School Press.
- Burgelman, R. A. (1983), "A Model of the Interaction of Strategic Behavior, Corporate Context, and the Concept of Strategy," *Academy of Management Review*, 8, 61–70.
- Dunphy D. C. and Stace, D. A. (1988), "Transformational and Coercive Strategies for Planned Organizational Change: Beyond the O.D. Model," *Organization Studies*, 9, 317–334.
- Drory, A. and Romm, T. (1990), "The Definition of Organizational Politics: A Review," *Human Relations*, 43, 11, 1133–1154.
- Eisenhardt, K. (1989), "Building Theories from Case Study Research," *Academy of Management Review*, 14, 532–550.
- Eisenhardt, K. and Graebner, M. E. (2007), "Theory Building from Cases: Opportunities and Challenges," *Academy of Management Journal*, 50, 25–32.
- Feltham, T. S., Feltham, G., and Barnett, J. J. (2005), "The Dependence of Family Business on a Single Decision-Maker," *Journal of Small Business Management*, 43, 1–15.
- Floyd, S. W. and Lane, P. (2000), "Strategizing throughout the Organization: Management Role Conflict in Strategic Renewal," *Academy of Management Review*, 25, 154–177.
- Ghoshal, S. and Bartlett, C. A. (1994), "Linking Organizational Context and Managerial Action: The Dimensions of Quality of Management," *Strategic Management Journal*, 15, 91–112.
- Hansen, G. S. and Wernerfelt, B. (1989), "Determinants of Firm Performance: The Relative Importance of Economic and Organizational Factors," *Strategic Management Journal*, 10, 399–411.
- Hrebiniak, L. G. (2006), "Obstacles to Effective Strategy Implementation," *Organizational Dynamics*, 35, 12–31.
- Jarzabkowski, P. (2008), "Shaping Strategy as a Structuration Process," *Academy of Management Journal*, 51, 621–650.
- Johnson, G., Melin, L. and Whittington, R. (2003), "Guest Editors' Introduction: Micro Strategy and Strategizing: Towards an Activity Based View," *Journal of Management Studies*, 40, 3–22.
- Katz, N., Lazer, D., Arrow, H., and Contractor, N. (2004), "Network Theory and Small Groups," *Small Group Research*, 35, 307–332.
- Langley, A. (1999), "Strategies for Theorizing from Process Data," *Academy of Management Review*, 24, 691–710.
- Miller, S., Wilson, D., and Hickson, D. (2004), "Beyond Planning Strategies for Successfully Implementing Strategic Decisions," *Long Range Planning*, 37, 201–218.
- Mintzberg, H. (1985), "The Organization as a Political Arena," *Journal of Management Studies*, 22, 134–154.
- Nutt, P. C. (1999), "Surprising But True: Half the Decisions in Organizations Fail," *Academy of Management Executive*, 13, 75–90.
- Pfeffer, J. (1981), *Power in Organizations*, Harper Business.
- Pettigrew, A. M. (1979), "On Studying Organizational Cultures," *Administrative Science Quarterly*, 24, 570–581.
- Reichers, A. E. and Schneider, B. (1990), "Climate and Culture: An Evolution of Constructs," in Schneider B. (Editor) *Organizational Climate and Culture*, Jossey-Bass, San Francisco.

- Schein, E. H. (1983), "Organizational Culture," *Organizational Dynamics*, 12, 13–28.
- Scott, W. R. (2008), *Institutions and Organizations: Ideas and Interests*, 3rd edition, Thousand Oaks, California, Sage Publications, Inc.
- Whittington, R. (2003), "The Work of Strategizing and Organizing: for a Practice Perspective," *Strategic Organization*, 1, 117–125.
- Yin, R. K. (2003), *Case Study Research – Design and Methods*, 3rd edition, Thousand Oaks, California, Sage Publications, Inc.

---

Miguel Ek Lopes is a Ph.D. candidate at the ISCTE–Business School of the Lisbon University Institute, UNIDE, Portugal. His major research interests are at the intersection of strategy–process and strategy–as–practice, the social role of people in strategy, managerial action, and organizational politics.

Nelson Campos Ramalho is an Assistant Professor at the ISCTE–Business School of the Lisbon University Institute and a researcher at UNIDE, Portugal. His major research interests are in the field of organizational behavior, effectiveness, and organizational politics.

Table No. 3 – The Episode Chronology (Timeline)

Timeline	Events
Day 1 Thursday	<i>Implementation Start</i> Unscheduled. Meeting with the Technician (Sales Director and General Manager). Goal: To present concrete changes and to and mobilize the Technician.
Day 4 Monday	<i>Formalization</i> Scheduled. Regular sales group meeting (General Manager present). Goal: Present new structure and way of working to the team. Result: A meeting is scheduled for the following Thursday for the Sales Director to implement the operational details with the Senior Technician.
Day 7 Tuesday	<i>Senior Technician Appeals</i> Unscheduled. Technician talks to Sales Director Technician seeks to delay Thursday’s meeting and to schedule a new meeting with the General Manager. Sales Director informs General Manager. Results: Thursday’s meeting is delayed. No meeting is scheduled with the Technician and the General Manager.
Day 8 Wednesday	<i>Technician Talks with the Technical Director</i> Unscheduled. Technician voices discontent over the changes.
Day 9 Thursday	<i>Coffee-Break between General Manager and Technical Director</i> Unscheduled. The Technical Director informs the General Manager about the Technicians’ discontent, showing concern about a possible exit of the Technician. General Manager replies that people cannot dictate policy and that only if the Technician threatens to leave would he be forced to back down.
	<i>General Manager Calls the Sales Director</i> Unscheduled. The General Manager calls the Sales Director and requests him to tell a Salesperson that he (the Sales Director) is concerned because the Technician is an important element.
Day 10 Friday	<i>Sales Director Gives Information to the General Manager</i> Unscheduled. The Sales Director reports to the General Manager that a salesperson told him that the Technician told the Sales group he would not be available to help salespersons with prospects and customers.
Day 13 Monday	<i>Technician Voices Exit to Colleagues of the Sales Group</i> Unscheduled. A worried salesperson calls the Sales Director telling him that the Technician said he would leave the company if forced to the new position.
	<i>The Sales Director Informs the General Manager</i> Unscheduled. Result: The General Manager requests that the Sales Director do nothing and to schedule a meeting with the Technician for next Thursday.

Day 16 Thursday	<i>Base Exit Agreement Is Established</i> Scheduled. Meeting with the Technician, General Manager, and Sales Director. Goal: Get the Technician to resign. Result: A meeting scheduled for the following Thursday with the purpose of signing an exit agreement.
(A week later) Thursday	<i>Exit Formalization</i> Scheduled. Result: Exit agreement is signed (short, to-the-point meeting).