

# Multifunctional design, feasibility and requirements for structural power composites in future electric air taxis

Journal of Composite Materials  
2022, Vol. 0(0) 1–11  
© The Author(s) 2022



Article reuse guidelines:  
[sagepub.com/journals-permissions](https://sagepub.com/journals-permissions)  
DOI: 10.1177/00219983221132621  
[journals.sagepub.com/home/jcm](https://journals.sagepub.com/home/jcm)



**Aneesa Ishfaq<sup>1</sup>, Sang N Nguyen<sup>1</sup> , Emile S Greenhalgh<sup>1</sup>, Milo SP Shaffer<sup>2</sup>, Anthony RJ Kucernak<sup>2</sup>, Leif E Asp<sup>3</sup>, Dan Zenkert<sup>4</sup> , and Peter Linde<sup>3,5</sup>**

## Abstract

This study investigates the viability of implementing multifunctional structural power composites in a four-seater air taxi, the CityAirbus. For a given specific energy of the power source, the cruise endurance can be approximately doubled by using structural power composites as opposed to conventional batteries. Replacing all the eligible composite mass and batteries with structural power composites can reduce the CityAirbus weight by 25%. To achieve the current design performance, the minimum required elastic modulus, strength, specific energy and power for the structural power composite are 54 GPa, 203 MPa, 74 Wh/kg and 376 W/kg, respectively: current state-of-the-art structural power composites are now approaching this level of performance. Hence, structural power composites are considered feasible for adoption in the urban air mobility sector and have the potential to improve endurance and facilitate commercialization. This paper also discusses several key challenges that must be addressed to realize the adoption of structural power composites in future electric air taxis.

## Keywords

structural power composites, multifunctional design, electric air taxi, requirements, feasibility, structural battery, structural supercapacitor

## Introduction and motivation

Structural power composites (SPCs)<sup>1–3</sup> are lightweight electrical energy-storing and load-bearing multifunctional materials. SPCs differ from multifunctional structures, such as batteries embedded into composites,<sup>4</sup> in that the constituents in SPCs intrinsically perform multiple functions. Hence SPC technology is more challenging to develop than embedded power sources, but can achieve a higher degree of integration,<sup>5</sup> and hence potentially, greater weight and volume savings through a larger proportion of the material contributing to multiple functions. To realise the promising weight and volume savings offered by SPCs, it is important to identify the required performance levels for different applications, such as aircraft cabins.<sup>6</sup> The study reported here provides an insight into potential synergies and the motivation and route maps for future adoption.

## Architectures

The principal devices used for electrical energy storage are batteries and supercapacitors. Batteries have high specific

energy  $E^*$  achieved through electrochemical processes, but low specific power  $P^*$  and cyclic performance. On the other hand, supercapacitors, which use physical charge transfer processes, have modest specific energy but superior specific power and longevity compared to those of batteries. Both structural battery composites (SBCs) and structural supercapacitor composites (SSCs) can have the same laminated architecture (Figure 1), consisting of two electrodes sandwiching an electrically-insulating but ionically-conducting

<sup>1</sup>The Composite Centre, Department of Aeronautics, Imperial College London, UK

<sup>2</sup>Department of Chemistry, Imperial College London, UK

<sup>3</sup>Department of Industrial and Materials Science, Chalmers University of Technology, Sweden

<sup>4</sup>School of Engineering Sciences, Engineering Mechanics, Vehicle Engineering and Solid Mechanics, KTH, Sweden

<sup>5</sup>German Aerospace Center (DLR), Germany

## Corresponding author:

Emile S Greenhalgh, The Composite Centre, Department of Aeronautics, Imperial College London, London SW7 2AZ, UK.

Email: [e.greenhalgh@imperial.ac.uk](mailto:e.greenhalgh@imperial.ac.uk)

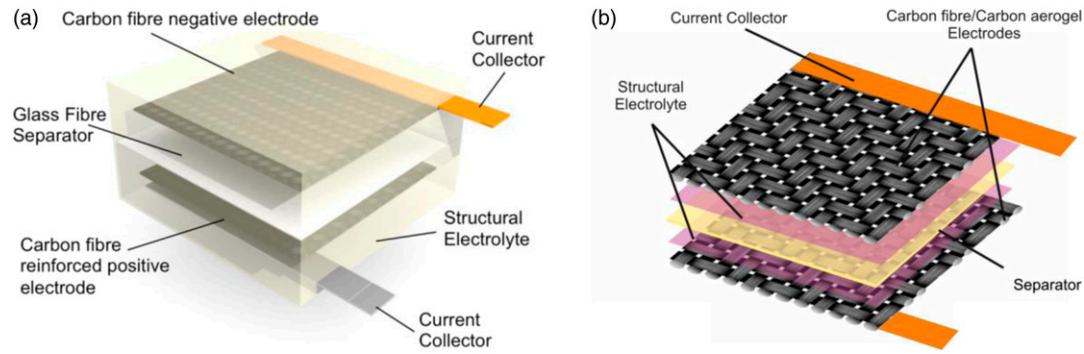

**Figure 1.** (a) Structural battery<sup>1</sup> and (b) structural supercapacitor<sup>7</sup> composite architectures.

separator. Both devices have adopted aligned and continuous structural fibres (i.e., aerospace carbon fibres) because such fibres offer high stiffness and strength, good electrical conductivity, scalable manufacture, and their surfaces can be functionalised to tailor the performance for their lithium (Li)-ion capacity in SBCs or for SSC applications. The high structural performance distinguishes such SPCs from the large body of work on flexible power sources, which use discontinuous and/or non-aligned nanocarbons as the electrode materials. Both types of SPC contain a structural electrolyte, the nature of which is dictated by the device chemistry. Since the electrode conductivity is lower than that for copper or aluminium, metallic current collectors are often attached to the device, and the whole device is encapsulated in an inert insulator. Although the structural electrodes, and to some extent the structural electrolytes, differ between SBCs and SSCs, the separators, current collection and encapsulation requirements and solutions are almost identical.

### Constituents

For SBCs, two different electrodes are required; the highest energy density systems currently use a lithium intercalation anode paired with an olivine cathode. In the anode, the carbon fibres (CFs) must be able to store ions in the fibre microstructure. Here, Li ions are inserted into the fibre during charge and removed during discharge. PAN-based carbon fibres have excellent electrochemical properties, almost on a par with the capacity of conventional graphite electrodes.<sup>1,8,9</sup> On the cathode side, the carbon fibres are used as a reinforcement, current collector and a scaffold for the cathode material: sub-micron particles such as lithium iron phosphate (LFP). The carbon fibres perform multiple functions in both the anode and the cathode leading to a multifunctional benefit.

For SSC electrodes, high surface area is paramount for electrochemical performance. However, pristine CFs have negligible specific surface area ( $0.21 \text{ m}^2/\text{g}^{10}$ ), so research effort has focused on increasing the surface area without

degrading the mechanical properties.<sup>11</sup> Chemically activating CFs ( $32.8 \text{ m}^2/\text{g}^{10}$ ) and/or grafting with nanocarbons ( $45.8 \text{ m}^2/\text{g}^{10}$ ) have been explored, but the improvements are limited. Other approaches have included decorating with conductive polymers and/or metal oxides ( $195.7 \text{ m}^2/\text{g}^{10}$ ) or hydroxides, which have given high electrochemical performance and some enhancements in mechanical performance.<sup>10</sup> One approach has been to use carbon aerogel (CAG), the precursor for which is infused through the dry fabric and then pyrolyzed to yield a CAG monolith which supports the CFs. CAG provides a high specific surface area of  $121 \text{ m}^2/\text{g}^{11}$  (giving high capacitance), fills the matrix space and mechanically supports the fibres.<sup>12</sup> However, CAG is brittle which impacts on the durability and device processability.

The structural electrolyte is critical to the device performance and is one of the most challenging aspects of this technology.<sup>13</sup> The structural electrolyte must permit ion transport to the electrodes, and be mechanically robust and strong: these aspects are usually in conflict. The structural electrolyte also needs to be chemically compatible with the other constituents, processable, scalable and provide a good mechanical bond at the interfaces between these constituents. Epoxies and vinyl esters are the most widely used structural polymer matrices in high performance composites; hence their modification has been investigated as the basis of structural electrolytes.<sup>10</sup> Lithium salts have been added to the polymers to enhance their ion transport, but only provided modest improvements. The addition of ionic liquids and battery electrolytes to the polymers is more promising, providing an interpenetrating network of the structural and ionic transport phases.<sup>13</sup> By controlling the proportions of the two phases, the balance between the mechanical and electrochemical performance can be tailored. However, challenges still remain: the liquid phase can accelerate polymer cross-linking, limiting the processing window. There are also issues with phase control during processing, leading to loss of the optimum microstructure. When the structural electrolyte is processed with the carbon fibres, the phases separate and form a gross heterogenous

microstructure rather than a homogenous bi-continuous microstructure.

Regarding the other device constituents (i.e., separators, current collectors and encapsulation), structural power separators have adopted those used in conventional devices, such as porous polymer films and non-woven veils. The separator must conduct ions, act as an electrical insulator and be very thin, robust, tolerant to the processing conditions, and chemically inert. It must provide good mechanical bonding to the electrodes without detriment to the ionic conductivity and mechanical performance. Conventional separators fall short of these requirements, and hence alternatives, such as woven spread tow glass fabrics have been used. These options can be overly thick or prone to distortion, leading to electrical shorting. ‘Separator-free’ devices have been attempted, but the large areas for structural devices and the consolidation pressures required for device manufacture make such a route very challenging.<sup>10</sup> Manufacturing larger areas leads to a greater probability of defects where the electrodes could come into contact and short-circuit the device. Despite the vital role of the separator, there has been little development of new separators for SPCs.

Efficient current collection is vital for device scale-up.<sup>14</sup> The role of the current collector is to minimise the resistive losses and should be chemically compatible with the other constituents and bond to the electrodes. Conventional electrochemical devices are manufactured by depositing the electrode onto a metallic foil current collector that accounts for as much as 25% of the total cell mass. For SPCs, such metal foils are not necessary nor optimal, and alternative current collector architectures which require only partial coverage with metal foil can save significant device mass.<sup>14</sup>

### Fabrication and properties

Methodologies for fabricating SPCs have drawn on conventional carbon fibre reinforced polymer (CFRP) composite manufacturing routes. The device chemistry has often used thermoset polymers, so methods such as prepregging, liquid resin or film infusion have been used for SSCs, whilst SBCs have been manufactured by hand lay-up inside a glovebox or with liquid resin infusion.<sup>8,9</sup> A multicell laminate consisting of three SBC cells in series integrated into a CFRP laminate has been demonstrated (Figure 2(a))<sup>15</sup> with the following multifunctional properties: elastic modulus  $E = 25$  GPa, strength  $\sigma = 312$  MPa,  $I^* = 24$  Wh/kg and  $P^* = 9.6$  W/kg.<sup>9</sup> In parallel, an electrochemical actuator laminate, akin to an SBC, with  $E = 100$  GPa has been demonstrated.<sup>17</sup> SSCs have experimentally demonstrated the following multifunctional device properties:  $E = 33$  GPa,  $\sigma = 110$  MPa,  $I^* = 1.4$  Wh/kg and  $P^* = 1.1$  kW/kg.<sup>11,18</sup> The mechanical properties were obtained from longitudinal tensile coupon tests on unidirectional

SBCs or plain weave SSCs. Multicell SSC demonstrators have been manufactured, including an automotive boot lid<sup>7</sup> (Figure 2(b)) and a fuselage rib that powers a desktop-scale aircraft door to open and close<sup>16</sup> (Figure 2(c)). Hence, SSCs are at technology readiness level (TRL) four, i.e., “component validation in a laboratory environment.”

### Design

Methodologies to assess multifunctional performance in various application scenarios<sup>9</sup> and using a new metric called ‘residual specific’ properties have been demonstrated.<sup>19</sup> Extended multifunctional design studies have considered the viability of using SPCs in various applications<sup>15,20</sup> and evaluate the corresponding benefits and challenges to widespread use, such as fire resistance, long-term cycling performance and cost. One study focused on SPC aircraft cabin floor panels to power the in-flight entertainment system.<sup>6</sup> Achieving  $E$ ,  $I^*$  and  $P^*$  properties of 28 GPa, 144 Wh/kg and 290 W/kg, respectively, can lead to a 34% weight reduction over the original cabin system (equivalent to an annual CO<sub>2</sub> reduction of 260 tonnes per aircraft).

Other multifunctional design studies have investigated the feasibility, benefits and challenges of using SPCs for electrification of automotive<sup>21</sup> and regional aircraft<sup>22</sup> to facilitate decarbonisation in these transport sectors. Whilst many of the studies have focused on fixed-wing aircraft and their propulsion systems, there is an emerging urban air mobility market for air taxis classed as electric vertical take-off and landing (eVTOL) aircraft. These eVTOLs are compact and can operate in complex and dense environments but have different propulsion and flying performance to those for fixed-wing aircraft. Thus, the energy and power models lead to different requirements for SPCs, which could influence whether electric air taxis or other types of all-electric aircraft may be adopted earlier.

The study reported here investigates the feasibility and implications of the potential application of SPCs in all-electric air taxis. Using specifications based on a reference air taxi, together with analytical and numerical techniques, this study investigates and models the potential performance improvements associated with the implementation of SPCs. This study will consider the necessary SPC properties to meet the design requirements and the implications on the endurance, weight and payload capacity of the air taxi. The current study only assumes a laminated CFRP architecture and not any specific SPC constituents. The constituents described in the Constituents section may change as the SPCs develop. The purpose of this study is to determine structural and electrochemical performance requirements for the proposed application such that researchers can select the constituents that they deem most suitable to be able to achieve these requirements. Embedded power sources or



**Figure 2.** Previous structural power demonstrators (a) panel with integrated SBCs<sup>15</sup>; (b) Volvo boot lid with integrated SSCs<sup>7</sup>; (c) fuselage rib with integrated SSCs.<sup>16</sup>

SBCs or SSCs or combinations of these options could be used, as long as the performance requirements are met.

## Methodology

This study applies the methodology developed and demonstrated in previous multifunctional design studies<sup>6,20,22</sup> comprising the following steps:

1. Select an all-electric air taxi for detailed investigation;
2. Calculate the energy and power requirements for this air taxi based on a generalised mission;
3. Determine minimum SPC structural requirements based on critical load cases;
4. Audit the air taxi structural weight to compute the mass of composites to be replaced with SPCs;
5. Model two cases (A and B) involving replacement of the composites and batteries with SPCs;
6. Determine the required specific energy and power of the SPC;
7. Compare the effects of implementing future battery and SPC technology (case C).

For this study, the CityAirbus (Figure 3) was selected as the reference vehicle because it is an all-electric vehicle, can carry multiple passengers to meet forecasted traffic growth, has undergone full-scale demonstrator flights, has the flexibility to operate in complex urban environments and sufficient data was available to enable structural weight and flight mission performance analyses with reasonable accuracy for conceptual design evaluation. The CityAirbus is a wingless eVTOL aircraft with four large, ducted propulsion units and four battery cells designed in-house by Airbus that were assumed to be Li-ion batteries because this battery type is the prevailing technology in electric vehicles. A mission profile was developed, based upon which the power and energy requirements for each flight segment were computed. The energy requirement is an accumulation of the energy for each flight segment within the nominal 15 min endurance profile (Table 1). The overall power requirement is governed by the flight segment with the maximum power demand: the hover segment. Detailed analyses of the power and energy requirements for each flight segment are provided in ref. 23. To

determine the uncertainties in the calculated specific energy and power, Monte Carlo simulations were used to determine the effects of propagation of uncertainties in the energy, power and masses, for which details are provided in ref. 23.

## Analysis cases

Structural power composites typically exhibit a trade-off between the electrical and structural performance such that the structural performance is below that of a conventional CFRP. For example, the fibre volume fraction achieved from consolidation of a SPC may be lower than that for a conventional CFRP. Hence it is important to consider the ratio of SPC to conventional CFRP elastic modulus,  $E^*$ . If  $E^* = 100\%$ , the SPC has the same modulus as a conventional CFRP that would be used for the air taxi structure. In this study, the structural analysis aimed to determine minimum requirements for the elastic modulus and strength and did not analyse the whole air taxi structure. The analysis focused on the floor panels because they were expected to experience the highest loads under the most critical load cases: compression and bending, which are stiffness (modulus) limited due to the potential for buckling. The analysis applied equations for sandwich panels under bending using dimensions for the floor panels estimated based on the overall dimensions given in Figure 3. Three cases (A, B and C) modelled various scenarios for the application of SPC, including the effects of how much SPC is used and its  $E^*$  (Table 2). The results were compared to the baseline configuration to assess the viability and attractiveness of SPCs in eVTOLs.

**Case A: Replace eligible mass with full  $E^*$  SPC, keep baseline total mass.** In case A, some or all of the eligible structure and batteries were replaced with 100%  $E^*$  SPC such that the maximum take-off weight (MTOW) remained 2450 kg. Hence the vehicle power and energy requirements were the same as those for the baseline configuration. The purpose was to determine the required SPC specific properties and whether the battery can be replaced with greater payload.

**Case B: Replace all composites and all batteries with SPC, and vary  $E^*$ .** In case B, all the eligible composite mass and

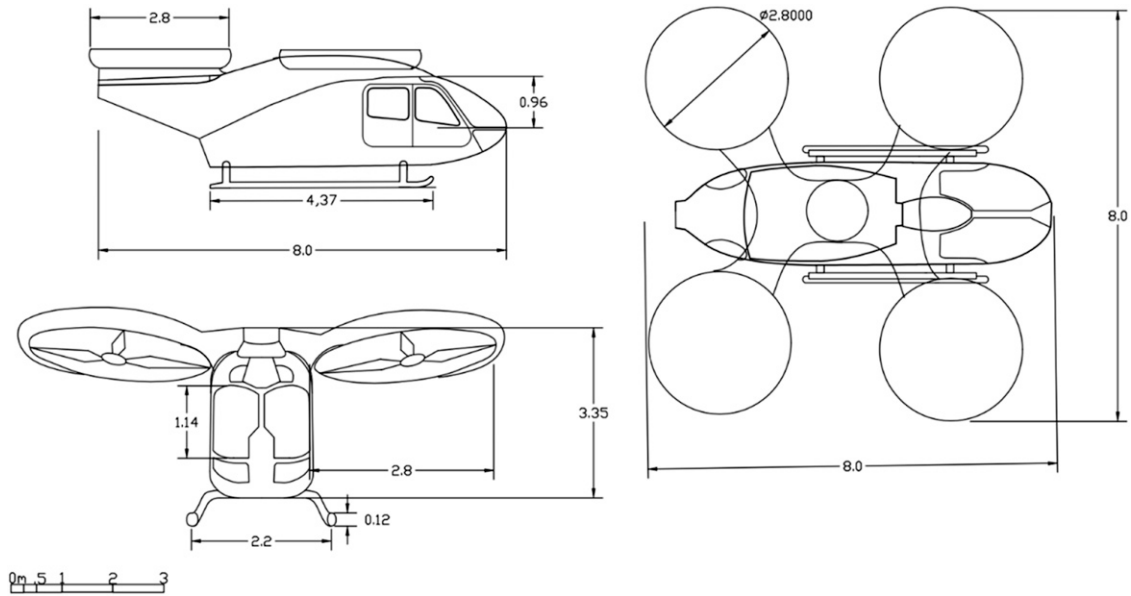

**Figure 3.** Drawings of the CityAirbus air taxi (dimensions in metres).<sup>23</sup>

**Table 1.** CityAirbus nominal specifications.<sup>23</sup>

Parameter	Value	Parameter	Value
Max. take-off weight (MTOW)	2450 kg	Number of propellers	8
Empty operating mass	2200 kg	Number of motors	8
Payload mass	250 kg	Passenger capacity	4
Total battery energy	110 kWh	Length	8 m
Battery power for one of four cells	140 kW	Height	8 m
Motor operating power	100 kW	Propeller diameter	2.8 m
Max. endurance	15 min	Cruise speed	120 km/h

**Table 2.** Analysis cases.

Case	Description
A	Replace a varying proportion of the composite and battery mass using SPC with a modulus equivalent to that of woven CFRP. Maintain the baseline configuration total mass
B	Replace all composites and all batteries with SPC and vary $E^*$ The overall mass depends on $E^*$
C	Compare cruise endurance when powered entirely by batteries or 100% $E^*$ SPC

batteries were replaced with SPC, such that the MTOW was (2450 - 550) kg = 1900 kg. The MTOW has a significant impact on the power and energy required to carry out the mission profile with the same endurance. To meet the structural requirements with a lower  $E^*$ , the SPC thickness and hence mass can be increased. For this study, different  $E^*$  values were considered under loading in bending, because considerable aerostructure design is driven by bending performance. Other material parameters were assumed to

remain constant. The relationship between the modulus and the dimensions of the material were established using the assumption of a rectangular plate, and for simplicity, only the thickness was modified. In this analysis, the minimum  $E^*$  was considered to be 25%, because for lower  $E^*$ , the take-off weight would exceed the original MTOW and hence negate any benefits. For this 25%  $E^*$  case, the SPC was assumed to fully replace all the eligible structure and battery mass.

**Case C: Comparison between SPCs and batteries.** Case C considered the performance with future technologies, in particular the trend of improving  $\Gamma^*$  in batteries for electric vehicles. To evaluate the influence of power source type for the CityAirbus, batteries and SPCs were compared by considering the CityAirbus cruise endurance based on a given pack-level  $\Gamma^*$  of the power source. Existing batteries have a  $\Gamma^* > 100$  Wh/kg, so this was the minimum value considered for the batteries. A pack-level  $\Gamma^*$  of 600 Wh/kg was considered as a target that batteries may reach over the next 20 years.<sup>24</sup> Comparatively, state-of-the-art (SOTA) SPCs have a lower  $\Gamma^*$  and so the range considered was 10 Wh/kg to 600 Wh/kg.

The following two configurations were considered: a baseline configuration (2450 kg MTOW including 550 kg batteries and 250 kg payload) and a SPC configuration (1900 kg MTOW including 939 kg SPC, no batteries and 250 kg payload). However, the most power intensive segment of flight, and cruise endurance were considered as key performance metrics. Details of the equations used for the power and energy calculations for these segments are provided in the Power and energy analysis section and full details of the numerical values used in these equations are provided in ref. 23. The cruise endurance (time in the cruise segment) was a key parameter, since the longer the cruise endurance, the greater the range of the aircraft, which provides operational benefits. The specific energies in the range stated above were multiplied by the power source mass to determine the available energy. This energy was then divided by the cruise power requirement, which depended on the total mass with that power source, to determine the cruise endurance. This endurance provided a common parameter with which to compare the two energy storage technologies but did not account for a full ground-air-ground mission profile.

### Power and energy analysis

The hover segment is primarily dependent on rotor disk loading<sup>25</sup>  $\delta$ , defined as the total aircraft weight  $W$  divided by the total area  $A$  swept by the eight propellers,  $\delta = W/A$ . The power required for hover is

$$P_h = W \sqrt{(\delta/(2\rho))} / \eta_h \quad (1)$$

where  $\rho$  is the air density at sea level and  $\eta_h$  is the hover system efficiency. The energy used during the hover segment depends on the hover time  $t_h$  and the efficiencies of the battery propulsion system;

$$E_h = P_h t_h / (\eta_b \eta_d) \quad (2)$$

where  $\eta_b$  is the battery charge-discharge efficiency and  $\eta_d$  is the primary-to-delivered electrical efficiency. Since the power calculation already accounted for  $\eta_h$ , it was not necessary to include  $\eta_h$  when computing the energy.

However, the efficiency related to the battery charge-discharge  $\eta_b$  was applicable here and for every other flight segment energy requirement.

The cruise segment contributes heavily to the total energy requirement of the mission, as cruise is the segment with the longest duration. The power in the cruise segment involves a force equilibrium where the lift  $L$  equals the weight and the thrust equals the drag  $D$ ,<sup>25</sup>

$$P_{cr} = W D V_{cr} / (L \eta_p \eta_e \eta_m) \quad (3)$$

where  $V_{cr}$  = cruise speed,  $\eta_p$  is the propeller efficiency,  $\eta_e$  is the electrical system efficiency and  $\eta_m$  is the motor efficiency. The energy expended in the cruise segment is

$$E_{cr} = P_{cr} t_{cr} / (\eta_b \eta_d) \quad (4)$$

where  $t_{cr}$  is the cruise time.

### Structural analysis

To determine minimum mechanical performance requirements, a simplified structural analysis was carried out on the CityAirbus by identifying the critical load case only for the structural component which was expected to experience the highest loads, the floor panels. Based upon this load case, minimum mechanical properties were identified for the SPC for this application. However, to ensure a safely-designed eVTOL with SPCs incorporated, all other loading cases and components must also be considered. Small rotorcraft must ensure stability of the aircraft in all loading scenarios during the flight.<sup>26</sup> For fatigue evaluation and damage tolerance, the structures are designed to withstand the worst-case scenario. To determine the minimum required elastic modulus  $E$ , the SPC floor panels were assumed to be sandwich panels with an aerospace grade honeycomb core.<sup>27</sup> Lopatin's method<sup>28</sup> for the buckling of a sandwich panel was used,

$$E = 12 N_{cr} (b/t)^2 / (\eta_{cr} t \zeta) \quad (5)$$

where  $\eta_{cr}$  is the critical buckling coefficient,  $t$  is the face sheet thickness (3 mm),<sup>27</sup>  $b$  is the panel width and  $\zeta$  is a correction factor given by  $\zeta = 1 + 3(h/t) + 3(h/t)^2$ , where  $h$  is the core thickness (7 mm). Before the onset of buckling, the critical compressive stress was calculated using<sup>29</sup>

$$\sigma_{cr} = 3.61 E (h/b)^2 \quad (6)$$

In bending, the maximum bending moment was computed as

$$M_{max} = w L^2 / 12 \quad (7)$$

where  $w$  is a uniformly distributed load (8.05 kN/m) based on the loading scenario considered above, and  $L$  is the panel

length (2.4 m). The maximum bending stress was calculated using

$$\sigma_{max} = 6M_{max} / (bh^2) \quad (8)$$

where  $b$  is the panel width (1.2 m), and  $h$  is the panel total thickness (10 mm). The maximum bending stress was lower than the buckling stress. Hence, the greater value was chosen to provide a conservative compressive strength requirement.

## Results and discussion

This section presents the results of the three analysis cases described in Table 2. The masses of the main sub-systems in the CityAirbus are shown in Table 3 and the maximum total eligible mass was 1489 kg (60% of the MTOW). The 2477 kg MTOW calculated from the mass audit in this study differed by only 1% compared with the nominal 2450 kg MTOW.<sup>23</sup> The components in bold in Table 3 were assumed to be eligible to be replaced by SPC. Structural components that could be made from conventional CFRP were considered eligible to be replaced with SPC. The maximum total structural mass that could be replaced was 1127 kg. However, the eligible structural mass that could be replaced by SPC was assumed to be smaller than this value because, in reality, the structure would be made from a hybrid of SPC and monolithic CFRP to protect the SPC. The assumed ratio of SPC mass to total composite mass was 83%, based on a ply ratio of 20 plies of SPC covered with two plies of equivalent areal weight CFRP at the inner surface and two plies of CFRP at the outer surface. Thus, the maximum eligible structural mass was 939 kg and the maximum total eligible mass including the batteries was 1489 kg. For the main systems, the masses (and proportions relative to the MTOW) were: eligible structure = 939 kg (38%), other = 738 kg (30%), batteries = 550 kg (22%) and payload = 250 kg (10%).

The calculated energy for the baseline mission was derived using the methodology outlined in the Power and energy analysis section applied to every flight segment of the baseline configuration and summing the energies for all

of the flight segments. The 68 kWh ( $\pm 8\%$ ) calculated energy for the baseline mission was compared with the nominal 110 kWh of the CityAirbus batteries.<sup>23</sup> The latter would have included additional energy, with an energy reserve factor of 1.62, to allow for a reserve mission, avoid reaching a low state-of-charge which would affect the battery life-time, and account for loss of capacity over time. The 172 kW ( $\pm 4\%$ ) calculated maximum power was compared with the CityAirbus nominal total battery power of 560 kW (140 kW per cell),<sup>23</sup> suggesting a power reserve factor of 3.26. These calculated electrical requirements were considered reasonable in that the calculated demands were much lower than the available energy and power indicating significant safety factors and redundancy, as expected. These values accounted for the uncertainty in the duration of each segment and the efficiencies of the systems. The flight segments can vary in duration and the total energy calculation depends on these durations. This study assumed nominal or expected durations but included uncertainties to account for potential differences between the assumed and actual durations. The system efficiencies were also inputs into the power and energy calculations and the calculations needed to assume efficiencies (that are provided and justified in detail in ref. 23.) and these efficiencies had uncertainties. The minimum required mechanical properties calculated from the analyses in the Methodology section were  $E \geq 54$  GPa and  $\sigma \geq 203$  MPa. To be conservative, both values included 5% error margins arising from propagation of associated uncertainties in the assumed loads and geometry used as inputs into the calculations.

### Case A: Replace eligible mass with 100% E\* SPC and keep baseline total mass

Case A keeps the baseline configuration MTOW of 2450 kg and SPCs replace a certain proportion of the eligible mass (structure plus battery). Introducing SPCs reduce the required  $I^*$  and  $P^*$  both by up to 63% (Table 4), compared to those for the baseline configuration. The reductions in the required  $I^*$  and  $P^*$  are primarily due to the increase in mass

**Table 3.** Mass breakdown for the main sub-systems of the CityAirbus.

Component	Mass (kg)	Component	Mass (kg)
Fuselage	557	Motors	392
Batteries	550	Avionics systems	42
Landing skids	176	Electrical wiring	40
Propeller blades	161	Battery cooling system	29
Seating	107	Canopy and windshield glass	28
Ducted fans	80	Furnishing, instrument panel and console	12
Rotor hub	46	Power distribution accompanying systems	7
Structural mass	1127	Total operational empty mass	2227

(of up to 2.7 times) in which energy could be stored. If SPCs replace only part of the eligible mass, the required  $\Gamma^*$  and  $P^*$  are inversely proportional to the proportion of eligible mass replaced. For example, if SPC replaced only half the eligible mass, the required  $\Gamma^*$  and  $P^*$  double. The specific property requirements for SPC proportions  $\geq 60\%$  are potentially achievable by SPCs which use the same chemistry as that of 160 Wh/kg lithium iron phosphate batteries.<sup>30</sup> The requirements are subject to the assumptions made in this study and apply for a short endurance mission of 15 min. For longer journeys, the required  $\Gamma^*$  will be higher but the required  $P^*$  remains the same, unless the  $P^*$  needs to increase to be able to charge the SPC to the required energy within the same charging time as that for the baseline.

### Case B: Replace all composites and all batteries with SPC and vary $E^*$

Weight savings from using SPCs can lower the total energy and maximum power requirements relative to those required for the baseline configuration. The change in the energy and power requirements depends on the weight saving with respect to the MTOW. To enable a fair comparison, this analysis considered the baseline to have an energy reserve factor = battery energy capacity/mission energy requirement = 110 kWh/68 kWh = 1.62 and a maximum power reserve factor = maximum battery power/maximum mission power = 560 kW/172 kW = 3.26. The analysis then assumed that the multifunctional SPC configuration needed to achieve these same reserve factors to match the conventional system performance. The analysis calculated the SPC total energy and maximum power requirements as the SPC configuration mission energy multiplied by the energy reserve factor and the SPC configuration maximum power multiplied by the power reserve factor. The analysis then divided these SPC total energy and maximum power values by the SPC masses to determine the  $\Gamma^*$  and  $P^*$  requirements (Table 5).

Replacing all composites and batteries with 100%  $E^*$  SPC requires  $\Gamma^* > 74$  Wh/kg and  $P^* > 376$  W/kg, leading to a vehicle weight saving of 25% (Table 5). It is very challenging/unrealistic to achieve 100%  $E^*$  (no structural degradation). Hence, this study investigated the effect of varying  $E^*$ . A SPC could be tailored to reach high  $E^*$  by having a high ratio of epoxy to electrolyte in the structural electrolyte, but the electrochemical performance is likely to reduce. The hypothetical 100%  $E^*$  case provides an upper bound on the  $\Gamma^*$  and  $P^*$  requirements, because reducing  $E^*$  increases the required SPC thickness and hence mass, which reduces the required  $\Gamma^*$  and  $P^*$ . Increasing the SPC mass also increases the MTOW and hence the required total energy and maximum power. The reduction in the required  $\Gamma^*$  and  $P^*$  with decreasing  $E^*$  is because the relative

**Table 4.** Case A (same total mass as the baseline) SPC electrical requirements ( $E^* = 100\%$ ).

SPC proportion (%)	SPC mass (kg)	$\Gamma^*$ (Wh/kg)	$P^*$ (W/kg)
20	298	369	1880
40	596	185	940
60	893	123	627
80	1191	92	470
100	1489	74	376

increase in the SPC mass is greater than the relative increase in the MTOW, energy and power requirements.

### Case C: Comparison between batteries and SPCs

The cruise endurance increases linearly with increasing  $\Gamma^*$  of both conventional Li-ion battery and SPC (Figure 4) and the hover endurance (not shown) has a similar trend. For a given  $\Gamma^*$ , the cruise endurance for the SPC design is almost double that for the battery design (Figure 4) because the structure has 1.7 times more mass than the batteries in which to store the energy, together with potential weight savings. A similar trend is expected for other electric aircraft or vehicles if they have a structural mass that is substantially higher than the battery mass, as is the case for the CityAirbus. For higher  $\Gamma^*$ , the absolute difference between the endurance gained by using SPC and that from equivalent  $\Gamma^*$  batteries becomes greater. These findings support similar studies which have concluded that SPCs can provide large improvements in endurance or range for electric aircraft<sup>5</sup> or electric cars.<sup>21</sup> The major source of the improved range and efficiency is the vehicle weight saving from the removal of the batteries if the structure provides sufficient energy and power. This weight saving means that less energy and power needs to be provided to complete the mission, which further reduces the specific energy and power needed for SPCs compared to those for batteries.

Considering the baseline CityAirbus has a limited endurance, constrained by current battery technology, this analysis defines the required  $\Gamma^*$  if the endurance was to be extended. For example, consider a 240 km flight, such as London to Manchester, and assume that the CityAirbus maintains its cruise speed of 120 km/h. Disregarding other flight segments for simplicity, the cruise time is 2 h. To achieve this cruise time, 370 Wh/kg batteries are needed (Figure 4) whereas SPCs require only 170 Wh/kg (54% lower  $\Gamma^*$  requirement). The battery configuration requirement is nearly double the nominal 200 Wh/kg pack-level  $\Gamma^*$  of the CityAirbus Li-ion batteries. Hence, SPCs can significantly lower the  $\Gamma^*$  and  $P^*$  requirements, which may reduce the likelihood of safety issues, such as thermal runaway leading to fires.



**Table 5.** Case B (SPC replaces all eligible mass) requirements, vehicle mass savings ( $S$ ) and SOTA SPC properties.

SPC mass (kg)	$E^*$ (%)	$E$ (GPa)	$\sigma$ (MPa)	$\Gamma$ (kWh)	$\Gamma^*$ (Wh/kg)	$P$ (kW)	$P^*$ (W/kg)	$S$ (kg)	$S$ (%)
939	100	70	600	85	91	434	462	550	25
955	95	67	570	86	90	438	459	534	24
1034	75	53	450	89	87	456	441	455	21
1183	50	35	300	96	81	490	414	305	14
1489	25	18	150	110	74	560	376	0	0
SOTA SBC <sup>9</sup>	36	25	312		24		9.6	0	0
SOTA SSC <sup>18,11</sup>	47	33	110		1.4		1100	0	0
Woven CFRP <sup>12</sup>	100	70	600		0		0	0	0
Li-ion battery	0	0	0		200		1018	0	0

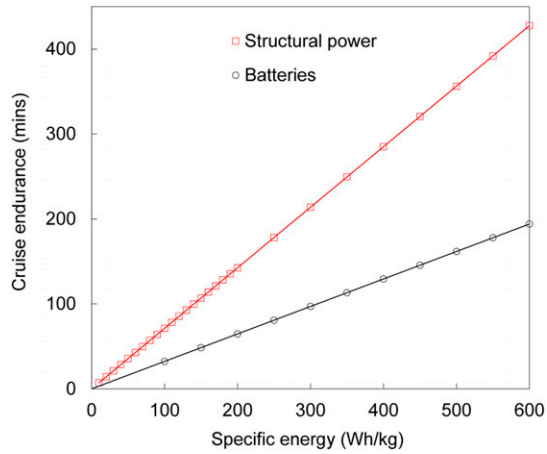
**Figure 4.** Cruise endurance for the CityAirbus powered by batteries or SPCs.

### Challenges to address for industrial adoption of SPCs

Some challenges and limitations with SPCs have not yet been fully addressed. The most challenging requirement is to reach both the  $\Gamma^*$  and  $P^*$  requirements (Tables 4 and 5) with a single device type. Recent progress suggests that SBCs will reach the required  $E$  and  $\Gamma^*$  within the coming years, but it is likely to take longer for SBCs to reach the required  $P^*$ . More research on efficient separator and structural electrolyte solutions is needed. SBCs hybridised with SSCs for their higher  $P^*$  may offer a solution to the high power demands in the short term. Since SBCs have common challenges to those of SSCs, the simpler electrochemistry of SSCs can be exploited to address generic issues associated with SPCs, such as scale up, and accelerate their development towards higher technology maturity.

Maintenance of SPCs presents key issues. Where batteries have the capability to be readily replaced by improved batteries at the end of life, SPCs do not have the same ease of replacement. SPCs that become damaged may require replacement, which can lead to significant repair costs. Developing high fatigue life and damage tolerance may be a

viable countermeasure. The requirements for fatigue and damage tolerance are also highly driven by crashworthiness requirements. The structural analysis in this study did not address these key aspects due to the lack of data available, such as experimental results regarding impact performance and certification requirements. Crashworthiness design is driven by both the geometry and material, and SPCs must be designed such that they can withstand impact loads to meet stringent regulations for vehicle applications.

Another engineering issue to consider is the resistance of SPCs to adverse environmental conditions to which the CityAirbus or other eVTOLs may be exposed. SPCs may not themselves withstand the environmental and aerodynamic flight conditions; hence external CFRP layers may be required to ensure integrity of the airframe under all conditions. Other safety-critical aspects to consider include flammability, smoke and toxicity in the event of a fire.

Regarding commercial practicality, future research needs to consider the required charging infrastructure and how this can fit into the wider urban transport landscape, such as using existing charging facilities for electric vehicles. Related factors to consider include the placement of the charging ports and the requirements for fast charging, as air taxis are likely to carry out repeated small missions with intermittent charging where possible. A low charge time would enable a high availability rate of the air taxi.

### Conclusions

This study theoretically investigates the feasibility and application of structural power composites in the CityAirbus by determining the required structural and electrical properties for various scenarios. Knowledge of the required performance levels can guide future SPC development and provide the motivation and route maps for future adoption of such technologies in an emerging aircraft concept. Baseline mechanical and electrochemical properties of monofunctional structural materials and batteries are  $E = 70$  GPa,  $\sigma = 600$  MPa,  $\Gamma^* = 200$  Wh/kg and  $P^* = 1018$  W/kg. Using SPCs with the same modulus as the

baseline structural material and keeping the same overall air taxi weight, the required SPC properties are  $\Gamma^* > 74$  Wh/kg and  $P^* > 376$  W/kg, only 37% of those for the baseline configuration batteries because the eligible SPC mass (structure plus battery) is 2.7 times the battery mass. Increasing the SPC mass increases the amount of energy that can be stored and reduces the required  $\Gamma^*$  and  $P^*$ .

Structural battery composites have experimentally demonstrated the following multifunctional device properties:  $E = 25$  GPa,  $\sigma = 312$  MPa,  $\Gamma^* = 24$  Wh/kg and  $P^* = 9.6$  W/kg.<sup>9</sup> Structural supercapacitor composites have experimentally demonstrated the following multifunctional device properties:  $E = 33$  GPa,  $\sigma = 110$  MPa,  $\Gamma^* = 1.4$  Wh/kg and  $P^* = 1.1$  kW/kg.<sup>11,18</sup> Providing further improvements continue and future research addresses the challenges for adoption discussed in this paper, SPCs are considered a viable prospect for electric air taxis and offer various design approaches to improve flight mission performance and increase payload. For instance, a 74 Wh/kg, 376 W/kg SPC could allow all the batteries to be replaced with 550 kg extra payload, making the CityAirbus significantly more commercially attractive. The methodology and findings from this study can be applied and extended to other electric air taxis and aerial vehicles such as drones, ideally at the conceptual design stage, to evaluate the requirements, feasibility and potential performance improvements, such as enhanced payloads.

### Acknowledgements

This work has been conducted by the combined efforts of Imperial College London (Departments of Aeronautics and Chemistry), Chalmers and KTH Royal Institute of Technology (Departments of Aeronautical and Vehicle Engineering and Chemical Engineering). The Swedish research group Kombatt is acknowledged for its synergism throughout this work. Data supporting this study are included within the article. For the purpose of open access, the author has applied a Creative Commons Attribution (CC BY) licence to any Author Accepted Manuscript version arising.

### Declaration of conflicting interests

The author(s) declared no potential conflicts of interest with respect to the research, authorship, and/or publication of this article.

### Funding

The authors disclosed receipt of the following financial support for the research, authorship, and/or publication of this article: This work was supported by the EU Clean Sky 2 SORCERER project [grant number 738085]; the EPSRC Future Composites Research Manufacturing Hub [grant number EP/P006701/1]; the EPSRC Beyond Structural project [grant number EP/P007465/1]; the European Office of Aerospace Research and Development [IOE grant number FA9550-17-1-0251]; the Royal Academy of Engineering [Chair in Emerging Technologies]; the Swedish Research

Council [grant numbers 2017-03898, 2020-05057]; the strategic innovation program LIGHTer [funding provided by Vinnova, the Swedish Energy Agency and Formas]; the Air Force Office of Scientific Research [grant numbers FA8655-21-1-7038, FA8655-21-1-7039]; and the Swedish Energy Agency [grant number 50508-1].

### ORCID iDs

Sang N Nguyen  <https://orcid.org/0000-0002-0942-1456>  
Dan Zenkert  <https://orcid.org/0000-0002-9744-4550>

### References

1. Asp LE, Johansson M, Lindbergh G, et al. Structural battery composites: a review. *Funct Compos Struct* 2019; 1: 042001.
2. Danzi F, Salgado RM, Oliveira JE, et al. Structural batteries: a review. *Molecules* 2021; 26: 2203.
3. Kalnaus S, Asp LE, Li J, et al. Multifunctional approaches for safe structural batteries. *J Energy Storage* 2021; 40: 102747.
4. Thomas JP, Pogue WR, Pham GT, et al. Flexure and pressure-loading effects on the performance of structure–battery composite beams. *J Compos Mater* 2019; 53: 2863–2874.
5. Adam TJ, Liao G, Petersen J, et al. Multifunctional composites for future energy storage in aerospace structures. *Energies* 2018; 11: 335.
6. Nguyen SN, Millereux A, Pouyat A, et al. Conceptual multifunctional design, feasibility and requirements for structural power in aircraft cabins. *J Aircr* 2021; 58: 677–687.
7. Asp LE and Greenhalgh ES. Structural power composites. *Compos Sci Technol* 2014; 101: 41–61.
8. Johannisson W, Ihrner N, Zenkert D, et al. Multifunctional performance of a carbon fiber UD lamina electrode for structural batteries. *Compos Sci Technol* 2018; 168: 81–87.
9. Asp LE, Bouton K, Carlstedt D, et al. A Structural battery and its multifunctional performance. *Adv Energy Sustain Res* 2021; 2: 2000093.
10. Xu Y, Lu W, Xu G, et al. Structural supercapacitor composites: a review. *Compos Sci Technol* 2021; 204: 108636.
11. Pernice MF, Qi G, Senokos E, et al. Mechanical, electrochemical and multifunctional performance of a CFRP/carbon aerogel structural supercapacitor and its corresponding monofunctional equivalents. *Multifunct Mater* 2022; 5: 025002.
12. Nguyen S, Anthony DB, Qian H, et al. Mechanical and physical performance of carbon aerogel reinforced carbon fibre hierarchical composites. *Compos Sci Technol* 2019; 182: 107720.
13. Wendong Q, Dent J, Arrighi V, et al. Biphasic epoxy-ionic liquid structural electrolytes: minimising feature size through cure cycle and multifunctional block-copolymer addition. *Multifunct Mater* 2021; 4: 35003.
14. Johannisson W, Carlstedt D, Nasiri A, et al. A screen-printing method for manufacturing of current collectors for structural batteries. *Multifunct Mater* 2021; 4: 35002.

15. Xu J, Geng Z, Johansen M, et al. A multicell structural battery composite laminate. *EcoMat* 2022; 4: e12180.
16. Anthony DB, Greenhalgh ES, Katafiasz T, et al. Structural supercapacitor composite technology demonstrator. In: 20th European Conference on Composite Materials, Lausanne, Switzerland, 20 June 2022, pp. 261–307. ECCM.
17. Johannisson W, Harnden R, Zenkert D, et al. Shape-morphing carbon fiber composite using electrochemical actuation. *Proc Natl Acad Sci* 2020; 117: 7658–7664.
18. Greenhalgh ES, Shaffer MSP, Kucernak AR, et al. Future challenges and industrial adoption strategies for structural supercapacitors. In: 22nd International Conference on Composite Materials. Melbourne, Australia, 11–16 August, 2019, pp. 1–23. ICCM22.
19. Johannisson W, Nguyen S, Lindbergh G, et al. A residual performance methodology to evaluate multifunctional systems. *Multifunct Mater* 2020; 2: 025002.
20. Carlstedt D, Johannisson W, Zenkert D, et al. Conceptual design framework for laminated structural battery composites. In: 18th European Conference on Composite Materials. Athens, Greece, 24–28 June, 2018, pp. 1–8. ECCM18.
21. Carlstedt D and Asp LE. Performance analysis framework for structural battery composites in electric vehicles. *Compos B Eng* 2020; 186: 107822.
22. Karadotcheva E, Nguyen SN, Greenhalgh ES, et al. Structural power performance targets for future electric aircraft. *Energies* 2021; 14: 6006.
23. Ishfaq A. *Analysis of system performance of structural power for future air vehicles (and beyond)*. London, UK: MSc Thesis, Imperial College, 2020.
24. The Faraday Institution. High-energy battery technologies, <https://faraday.ac.uk/wp-content/uploads/2020/01/High-Energy-battery-technologies-FINAL.pdf> (2020, accessed 28 April 2022).
25. Kasliwal A, Furbush NJ, Gawron JH, et al. Role of flying cars in sustainable mobility. *Nat Commun* 2019; 10: 1555.
26. European Aviation Safety Agency. Certification specifications for small rotorcraft CS-27, [https://www.easa.europa.eu/sites/default/files/dfu/CS-27\\_Amendment\\_3.pdf](https://www.easa.europa.eu/sites/default/files/dfu/CS-27_Amendment_3.pdf) (2012, accessed 28 April 2022).
27. Xiao Y, Hu Y, Zhang J, et al. The bending responses of sandwich panels with aluminium honeycomb core and CFRP skins used in electric vehicle body. *Adv Mater Sci Eng* 2018; 2018: 1–11.
28. Lopatin AV and Morozov EV. Buckling of a uniformly compressed composite rectangular CCCC sandwich plate. *Compos Struct* 2014; 108: 332–340.
29. Timoshenko SP and Gere JM. *Theory of elastic stability*. Mineola, NY: Dover Publications, 2012, 319–429.
30. Sabihuddin S, Kiprakis A and Mueller M. A Numerical and Graphical Review of Energy Storage Technologies. *Energies* 2015; 8: 172–216.