

Open Research Online

The Open University's repository of research publications and other research outputs

Developing the Professional Knowledge of Teachers of Technology and STEM in Secondary Schools

Thesis

How to cite:

Banks, Frank (2022). Developing the Professional Knowledge of Teachers of Technology and STEM in Secondary Schools. PhD thesis The Open University.

For guidance on citations see [FAQs](#).

© 2022 Frank Banks



<https://creativecommons.org/licenses/by-nc-nd/4.0/>

Version: Version of Record

Link(s) to article on publisher's website:
<http://dx.doi.org/doi:10.21954/ou.ro.00014dba>

Copyright and Moral Rights for the articles on this site are retained by the individual authors and/or other copyright owners. For more information on Open Research Online's data [policy](#) on reuse of materials please consult the policies page.

oro.open.ac.uk

**Developing the Professional Knowledge of
Teachers of Technology and STEM in Secondary Schools**

Frank Reginald John Banks

BA, PGCE (York) BA, MA (Open) C. Phys., F. Inst. P.

**A Thesis Submitted to The Open University for
the degree of**

Doctor of Philosophy by Published Work

2022

Volume One

Declaration

This work has not been submitted for any other degree or award at this or any other university or place of learning, nor is it being submitted concurrently for any degree or other award.

I confirm that this is my own work and the use of material from other sources has been properly and fully acknowledged and all use of jointly published work has been acknowledged and agreed.

Dedication

I dedicate this thesis to my wife, Pam Banks. She has, for 50 years, inspired, encouraged, supported, and enabled all that I have achieved as a schoolteacher and teacher educator.

I also dedicate this thesis to my children Chris, John, and Tim. I am incredibly proud of you and the contributions you make to the entertainment, education, and welfare of others.

Finally, I dedicate this thesis to my wonderful grandchildren, Ellie, Emma, Jamie, Alfie, Arlo, and Romy. It is in your generation that the contributions made to STEM education will make the most impact on the world. You are our future.

Acknowledgements

In this thesis by published work my collaboration with others is declared. I would like to thank my joint authors of those publications for giving me permission to submit our joint works, namely: Professor Bob Moon, my colleagues on the international DEPTH (Developing Professional Thinking for Technology Teachers) project, Professor Ann Shelton Mayes, Professor P. John Williams, Professor Vanwyk K.M. Chikasanda, Professor Bob McCormick and Dr David Barlex (aka Dr Hilda Ruth Beaumont).

What is not so visible are the contributions to my ideas and thinking about teacher professional knowledge that have developed over so many years and in many different contexts. My thanks in that regard go to Professor John Parkinson and Professor Richard Daugherty formerly of the Education Department, University of Wales, Swansea for our collaborations in curriculum, assessment and learning; to the late Professor Jenny Leach at The Open University whose formidable intellect saw so clearly how my empirical research could be exploited in so many of our national and international developments. I also acknowledge the other Open University colleagues who were fellow members of the then Centre for Research and Development in Teacher Education (CRete) who shared so freely their experiences and understanding of teachers and teaching.

I acknowledge all that I learned from the pupils I taught in high schools in England and in Wales, and from the many teachers who I was privileged to work with and observe in their classrooms. This was not only instructive but inspirational.

Finally, I would like to acknowledge the major contribution to teacher education of my colleague Dr Steve Hutchinson who amongst his many achievements at The Open University

was the instigator of the major support to teachers and to teacher educators that was carried out in India. More significantly, however, he has been my supervisor, guide, and critical friend in the production of this thesis. For that he has my deep gratitude – thank you.

Abstract

The sixteen works presented in the thesis derive from eleven years as a teacher of Science, Technology, Engineering and Mathematics (STEM) in different secondary high schools in England and in Wales, and as a researcher and teacher educator for twenty-seven years, as first an educator of physics teachers at the University of Wales, Swansea from September 1987 and then of technology and science teachers at The Open University beginning in April 1992.

The selected publications provide a unique 33-year arc of development and an interconnected overview of the way that an understanding of the elements of professional knowledge for teachers can be investigated and the results then used in the creation and the on-going development of initial and in-service teacher education programmes. The sixteen publications' contribution to the field and their resulting impact is demonstrated, for example, by their having been cited 479 times.

Using and exploiting a range of evaluative research methods that can be described as Research and Development (R&D), this thesis considers publications which address the education of teachers in general, and Design and Technology teachers and STEM teachers in particular. The publications coalesce around three interconnected themes that address three critically important research questions:

Theme 1. Teacher Professional Knowledge - **Research Question 1 (RQ1):** What are the elements of teacher professional knowledge and what is their inter-relationship?

- Empirical research conducted, and the resulting development of a general model of teacher professional knowledge (publications 1 – 4).
- Exploitation of the model as a ‘Graphical Tool’ through an international collaboration in the DEPTH Project (Developing Professional Thinking for Technology Teachers) (publications 5 and 6).

Theme 2. Developing Teachers of Technology - **Research Question 2 (RQ2):** In what ways can the suggested elements of teacher professional knowledge support the development of teachers of Technology?

- Empirical research on teaching and learning and teacher education in technology education.
- Development of approaches and models in technology teacher education including open and distance learning techniques (publications 7 – 10).
- Comparative classroom-based research providing international perspectives in teaching technology (publications 10 – 13).

Theme 3. Developing Teachers of STEM - **Research Question 3 (RQ3):** In what ways can the suggested elements of teacher professional knowledge support the development of teachers of STEM?

- Empirical studies and a critical analysis of the relationship between science and technology in the UK.
- Development of strategies both in teaching and in school organisation that need to be addressed when helping teachers meet the challenge of teaching STEM in the secondary school (publications 14 – 16).

Using a research and development (R&D) methodology to evaluate and build on courses to develop teacher professional knowledge and addressing the Research Questions, the key concepts that the thesis contributes to new knowledge are:

RQ1:

- The discovery, verification, and exploitation of a new way to conceptualise the common aspects of teacher professional knowledge across subject domains.
- The development of a graphical tool to explore teacher professional knowledge, and the discovery that teachers can use it to investigate and share professional understandings in their own contexts, demonstrating its applicability across education regimes internationally.

RQ2:

- The development of new open and distance learning techniques for the professional development of Technology teachers through the use of new technologies.

RQ3:

- The exploration, and dissemination of in-school strategies that can be used to develop and support secondary teachers of STEM, wherever they are located, by enabling them to collaborate by ‘looking sideways’ at the work that is done by colleagues in the contributory STEM subjects; and ways in which those developments can be supported by school leaders.

Contents

Declaration	i
Dedication	ii
Acknowledgements	iii
Abstract	v
List of Figures	xi
List of Tables	xii
List of abbreviations and acronyms	xiii
Chapter 1 Background and Context	1
1.1 The Research Questions	2
1.2 A consideration of the methodological approaches to Research and Development	6
1.3 Biographical background	13
1.4 The changing context of technology and STEM education	24
1.5 Structure of the thesis and an overview of the publications	36

Chapter 2 Theme 1: Teacher Professional Knowledge	46
2.1 Literature review of Teacher Professional Knowledge	47
2.1a Phase 1: The initial empirical studies	47
2.1b Phase 2: Theoretical Development and empirical verification of a revised summary diagram	56
2.1c Phase 3: The use of a Graphical Tool	75
2.2 The contributions of the published works to the research on Teacher Professional Knowledge	76
2.2a The contribution of the initial empirical studies	76
2.2b The contribution of the theoretical development and empirical verification of a revised summary diagram	85
2.2c The contribution of the use of a Graphical Tool	89
2.3 Conclusion	101
Chapter 3 Theme 2: Developing Teachers of Technology	103
3.1 Literature review of technology teacher education	104
Part 3.1a Teaching teachers of technology – the focus on pedagogy.	104
Part 3.1b Teaching teachers of technology – the focus on course methodology	111
Part 3.1c Teaching teachers of technology – the international context.	135
3.2 The contributions of the published works to the research on developing teachers of technology	140
Part 3.2a The contribution of teaching teachers of technology – the focus on pedagogy.	140
Part 3.2b The contribution of teaching teachers of technology – the focus on course methodology	143
Part 3.2c The contribution of Teaching teachers of technology – the international context	146

3.3 Conclusion	149
Chapter 4 Theme 3: Developing Teachers of STEM	151
4.1 Literature review on developing teachers of STEM	152
4.2 The contribution to the research on developing teachers of STEM	163
4.3 Conclusion	167
Chapter 5 Conclusion – Contribution to new knowledge and a summary of reception and impact in the field.	169
5.1 Contribution to new knowledge	169
5.2 Impact in the field	171
References	177
Appendix 1: Reviews of Publication 16	188
Appendix 2: Open University Observation form	200
Appendix 3: Time Sampling TEACHER Behaviour During the Lesson – Bangladesh.	202

List of figures

Figure 1: Display of results from the empirical study of 17 OUPGCE Design and Technology Student teachers	50
Figure 2: Core competences for Design and technology and fields of knowledge	54
Figure 3: Diagrammatic representation of a student's 'minimum competences'	55
Figure 4: Teachers' professional knowledge	62
Figure 5: An apparent "clashing currents" board diagram	66
Figure 6: Simulation of 'electrons' in a wire	68
Figure 7: Teacher Professional Knowledge - Empirical work verified the above diagram as discussed in Section 2.1 Phase 2. This diagram was used in the 2020 accreditation document for the new OUPGCE in Wales.	86
Figure 8: Example completed for design and technology in England	87
Figure 9: PGCE English student's designation of professional knowledge	88
Figure 10: Mentor of English student's designation of teacher professional knowledge	88
Figure 11: Mathematics teacher's designation of teacher professional knowledge	89
Figure 12: Use of teacher professional knowledge diagram by MacGregor	91
Figure 13: A conceptual framework for understanding the teaching of intermediate technology education in Newfoundland and Labrador.	93
Figure 14: An integration of the models of Banks <i>et al.</i> (2004) and Stein <i>et al.</i> (2000)	99
Figure 15: Curriculum emphases which need to be addressed by whatever teacher professional development structure is in place.	116
Figure 16: The resources available to a pre-service technology teacher following the OUPGCE.	118
Figure 17: OUPGCE competence model (1994)	119
Figure 18: Synthesising the teacher professional knowledge and CPD on-line pedagogy	122
Figure 19: Screen shot of the TeachandLearn science 'homepage'	123

List of Tables

Table 1: The rationale for the selection of each publication.	37
Table 2: Survey results of Technology teacher subject knowledge	52
Table 3: Rank difficulty in teaching a topic	79
Table 4: Teachers' rank of importance of different teaching strategies	80
Table 5: Examples of knowledges at work in technology classroom investigations	84-85
Table 6: Categorising value judgements	106
Table 7: Findings of a study of gender issues in Design and Technology	109-110
Table 8: School break-down in Quantitative study	129
Table 9: School break-down in Qualitative study	130

List of abbreviations and acronyms

BS – Business Studies

CAD /CAM – Computer Aided Design/Computer Aided Manufacture

CATE – Council for the Accreditation of Teacher Education

CCEA – The Council for the Curriculum, Examinations and Assessment (Northern Ireland)

CDT – Craft, Design and Technology

CfE – Curriculum for Excellence (Scotland)

CReTE – Centre for Research in Teacher Education

DATA – Design and Technology Association (Teacher Subject Association)

D&T – Design and Technology

DEPTH – Developing Professional Thinking for Technology Teachers

DfE – Department for Education

DMAs – Design and Make Assignments

EBacc – English Baccalaureate

FPTs – Focused Practical Tasks

GCSE – General Certificate of Secondary Education (Examinations taken at age 16 in England, Wales and Northern Ireland)

HE – Home Economics

HMI – Her Majesty’s Inspectors

Hwb – A website and collection of on-line tools provided to all schools in Wales by the Welsh Government.

LEA – Local Education Authority

NGO – Non-Governmental Organisation

OfSTED – Office for Standards in Education

OU – The Open University, UK.

OUPGCE – Open University Postgraduate Certificate in Education

R&D – Research and Development

STEM – Science, Technology, Engineering and Mathematics

SQA – Scottish Qualifications Authority

TTA – Teacher Training Agency

T&L – Teach and Learn or TeachandLearn.net

TESSA – Teacher Education in Sub Saharan Africa

TESS India – Teacher Education through School-based Support

TVEI – Technical and Vocational Education Initiative

WJEC – Welsh Joint Examination Committee

Chapter 1 Background and Context

What do ‘good’ teachers know? This simple question has been central to my thinking and research interests since 1987 when I first became a teacher-educator and was tasked with developing a course to prepare physics student teachers for their new career in secondary schools. Secondary school teachers are usually teachers of a specific subject so an expert teacher will have appropriate subject knowledge. However, the breadth of subject knowledge needed to teach science to a 13-year-old contrasts starkly with the depth of subject knowledge required to teach physics at pre-university level. In 1990 Technology became part of the compulsory school curriculum in England and Wales between the ages of 5 to 16, and at The Open University I was appointed in 1992 to develop a novel open and distance initial teacher-education course in this new subject. What subject knowledge in Technology was needed to teach this rapidly developing curriculum area? Of course, whatever the subject, a preparatory teaching course also needs to also focus on and promoting an appropriate pedagogy. How can we develop and improve courses that produce ‘good’ teachers beginning their first teaching post, and how can in-service courses be created that support experienced teachers as curriculum changes and new teaching strategies are proposed?

There is a thread that runs through the sixteen publications considered in this doctoral submission, which is the importance of teachers developing, recognising and being able to articulate their professional knowledge. This is the over-arching problem addressed by this thesis. Developing an appropriate teacher professional knowledge was particularly important for the new curriculum area of Technology so that teachers from a wide range of backgrounds such as craft, textiles, graphic design, domestic science and electronics, control and systems could come together to forge the new subject. Later, as teachers work together

to introduce STEM (Science, Technology/Engineering and Mathematics) into their schools there is the challenge of a further integration of teaching expertise and other professional knowledge to establish a STEM curriculum, with appropriate pedagogy, for the benefit of learners. This thesis will discuss the importance of a teacher's own 'personal subject construct' – what the teacher thinks is the core purpose of their subject contribution and how they enact that in their teaching. It is a complex amalgam of past knowledge and experiences of learning, a personal view of what constitutes 'good' teaching, and their belief in the purposes of what they see in the curriculum and why they wish to teach it. This all underpins a teacher's professional knowledge, and every teacher must discover, articulate, test and re-test this personal construct as they gain experiences in schools. Clearly, for any teacher, their personal subject construct is in continuous development as they respond to teaching innovation and the ever-changing curriculum, but a student teacher in particular has to question his or her initial personal beliefs about their subject and their assumed practice; and develop their pedagogical approach as they work with their mentor and the pupils to address and co-construct a rationale for their classroom behaviours.

The publications submitted in this thesis, which span a period of 33 years, coalesce around three interconnected themes that address three critically important research questions in the field of teacher professional knowledge. The principal aim of the thesis is to investigate, set out and articulate the elements of teacher professional knowledge and how such knowledge can be developed through initial and continuing teacher-education courses.

1.1 The Research Questions

The purpose and aim of this thesis as discussed above leads to the three interconnected themes and the related set of research questions, which I intend to address using the data from

the selected publications. The discussion not only addresses the following research questions but also indicates how the publications have had an international impact on the field. The publications coalesce around one of the three linked themes, which address a specific research question, and are set out as follows:

Theme 1. Teacher Professional Knowledge

Research Question 1 (RQ1): What are the elements of teacher professional knowledge and what is their inter-relationship?

This is the main research question which this thesis aims to address and themes 2 and 3 also consider aspects of this.

- Publications 1 – 4 set out to address the research question by empirical research conducted through several evaluations studies and resulting in a pictorial general model of teacher professional knowledge.
- Publications 5 and 6 illustrates the international exploitation of the pictorial model as a ‘Graphical Tool’ through a cross-continent collaboration in Technology teacher education – the DEPTH Project (Developing Professional Thinking for Technology Teachers).

Theme 2. Developing Teachers of Technology

Research Question 2 (RQ2): In what ways can the suggested elements of teacher professional knowledge support the development of teachers of Technology?

- This research question is considered through empirical research conducted on teaching and learning in technology education with a particular focus on Pedagogical Knowledge.

- Publications 7 – 10 consider the research question through the development of approaches and models in technology teacher education including open and distance learning techniques.
- Publications 11 – 13 address the research question through comparative classroom-based research providing international perspectives in teaching Technology.

Theme 3. Developing Teachers of STEM

Research Question 3 (RQ3): In what ways can the suggested elements of teacher professional knowledge support the development of teachers of STEM?

- In publications 14 and 15 the research question is considered through empirical research conducted on teaching and learning and teacher education in both Science and Technology education in the UK, particularly the importance that STEM education is grounded in real-life problems and with entrepreneurial considerations.
- Publications 16 address the research question by addressing both the different collaborative strategies for teaching STEM and in the school organisation that needs to be addressed when helping teachers meet the challenge of teaching STEM in the secondary school.

The research questions are addressed largely chronologically, drawing on the 33 years span of publications using a Research and Development (R&D) methodology where courses are evaluated, and new ones created in light of the outcomes of the former (see section 1.5).

The publications, in addition to providing data that addresses the above research questions, were also selected to address aspects of the Technology and STEM curriculum as follows:

The Specified Curriculum

This is the curriculum content as found in official documents and local agreements. In many parts of the world the specified curriculum as a legal requirement is being downplayed and schools are freer nowadays to construct their own curriculum. However, if teachers themselves are not part of the discussion on what technology or STEM in school should be, there may be a clash between their personal subject construct and the curriculum specified by others. This was particularly highlighted when existing schoolteachers were required to introduce the new subject of Technology into their school. In some of the publications, the specified curriculum refers to that required for initial teacher education. Over the years, such requirements were specified in the UK by the Council for the Accreditation of Teacher Education (CATE), the Teacher Training Agency (TTA) and the Department for Education (DfE).

The Enacted Curriculum

This is what teachers teach and so is highly dependent on the types of professional knowledge teachers need to bring to bear to plan and implement their teaching.

The Experienced Curriculum

This the understanding gained – the pupil learning; it is how both of the above are interpreted and made sense of by pupils.

The rationale for the selection of the sixteen publications has been dependent on their contribution to a research question and the way that they can also address the Specified,

Enacted and, to some extent, the Experienced Curricula of Science, of Technology and of STEM.

1.2 A consideration of the methodological approaches to Research and Development.

It is a truism that ‘Educational researchers study the world of teaching and learning in order to understand, inform and improve practice’ (Mears, 2021, p. 223).

In order to explore the research questions RQ1 – RQ3 outlined in section 1.1 a research ethos used across the publications presented in this thesis could be described as ‘Research and Development’ (R&D). As summarised in Table 1, the publications have been selected to illustrate a series of evaluation studies of the teacher education programmes for science and for technology teachers both in the UK and abroad, which provided both quantitative and qualitative data to inform how programmes offered could be improved, but also fed into the design of future teacher education developments, the better to address the teacher professional knowledge required for teachers of Technology or of STEM.

In their discussion of the returns for industrial R&D, (Levin *et al.*, 1988, p. 1) point out that:

To have the incentive to undertake research and development, a firm must be able to show appropriate returns sufficient to make the investment worthwhile. The benefits that consumers derive from an innovation, however, are increased if competitors are able to imitate and improve upon the innovation to assure its availability on favorable terms. Patent law seeks to resolve this tension between incentives and innovation and widespread diffusion of benefits.

If 'Patent Law' is changed to 'Copyright Law' (even under creative commons licences), the above quotation is a very close match to the model of course production at the Open University in general and for the OU teacher-education developments in particular.

The evaluation studies which are the 'Research' in the R&D approach, use a range of quantitative and qualitative techniques, although due to the relatively small number of student teacher and in-service teachers studied, there is an emphasis on qualitative approaches. The specific evaluation studies set out in the publications themselves provide data that inform the research questions. This is, in particular, set out and discussed in **Publications 1¹, 2², 5³, 8⁴, 11⁵, 12⁶, 13⁷, and 14⁸**. However, the quantitative and qualitative research methodologies that cut across these publications and the ethical standpoint taken throughout are, for further clarity, set out here.

Observing Classroom Interactions

Two sorts of classroom observation protocol were adopted across the publications. Classroom observation of Open University students used an interpretive protocol similar to the one discussed in appendix 2 to **Publication 1** at Swansea. Appendix 2 (page 201) shows a free

¹ Banks, F. R.J. (1988) A Preliminary Evaluation of the Two-Year PGCE and Diploma in Physics, Swansea: University College Swansea.

² Banks, F.R.J. (1996) 'Developing professional knowledge during initial design and technology teacher education', *Journal of Design and Technology Education*, Vol. 1 (2) pp. 175-178.

³ Banks, F., Barlex, D., Jarvinen, E-M, O'Sullivan, G., Owen-Jackson, G. and Rutland, M. (2004) 'DEPTH - Developing Professional Thinking for Technology Teachers: An International Study', *International Journal of Technology and Design Education*, **14** (2) 141-157.

⁴ Banks, F. (2009) 'Research on Teaching and Learning in Technology Education' in Jones, A. and de Vries, M. (eds.) *International Handbook of Research and Development in Technology Education*, Sense Publications: Rotterdam, pp. 373-390.

⁵ Banks, F. and Williams, P. J. (2013) 'International perspectives on technology education' in Owen-Jackson, G. (ed.) *Debates in Design and Technology Education*, London: Routledge, pp. 31-48.

⁶ Banks, F. (2011) 'Technological Literacy in a Developing World Context: The Case of Bangladesh' in de Vries, M. (ed.) *Positioning Technology Education in the Curriculum*, Sense Publishers, Rotterdam, pp. 219-226.

⁷ Banks, F. and Chikasanda, V. (2015) 'Technology Education and Developing Countries' in Williams P.J., Jones, A. and Bunting, C. (eds.) *The Future of Technology Education*, Springer: Singapore, pp. 217-238.

⁸ Banks, F. and McCormick, R. (2006) 'A Case Study of the Relationship between Science and Technology: England 1984-2004' in de Vries, M. J. and Custer, R (eds.) *International Handbook of Technology Education*, Sense Publications, Rotterdam, pp. 285-312.

response observation format, only constrained by the need for a focus on the competence standards (Banks 2006b, 2009). Here as in **Publication 4** and **Publications 12** and **13**, observations have been used ‘in studies that attempt to characterise instructional quality within and across populations’ (Gitomer, 2021, p. 222). However, the observation protocols were very different. The Open University students were observed using the open observation format shown in Appendix 2 giving qualitative data. In classrooms in Bangladesh, it was necessary to carry out a base-line observation of teaching in order to determine if the work done in the UK Aid-funded English in Action (EIA) programme achieved the desired change in classroom practice. In contrast, therefore, classroom observation of technology teachers in Bangladesh used the same strict time-based approach as EIA to ensure consistency across different observers. Appendix 3 shows an example of the timed observation protocols used in the research for **Publications 12 and 13**.

In-depth Interviews

Interview techniques were used to investigate the backgrounds of physics teachers in **Publication 1** and the prior experiences of ITT design and technology teachers on the OUPGCE (Banks, 1997). This is an example of a pragmatic approach as the student teachers were interviewed, and audio recorded, in their own homes which were usually many miles away from the Open University. Although practically difficult, this circumstance enabled the interviews to take place in the student teachers’ own secure environments which, perhaps, made them comfortable about ‘speaking their own mind’. Follow-up in-depth interviews also, when these were possible, supported and clarified any classroom observations conducted. The post- classroom observation in-depth discussion with ‘Geoff’ and ‘Alun’ illustrated in Section 2.1b is a key element of the empirical underpinning for **Publication 4**

and represents an example of the mixed methods used to explore Research Question 1. But as Mears (2021, pp. 232-233) observes:

Graduate students [...] often consider an interview-based approach for their research under the mistaken assumption that interviewing is ‘easy’. But don’t be fooled! Interviewing for research requires a great deal of preparation, purposeful conduct and attentive listening.

The interviews following classroom observation were a particularly important opportunity to clarify and triangulate the evidence seen in the classroom.

In **Publication 5**, the international study also conducted interviews following a deployment of the ‘Graphical Tool’. This provided a pictorial third-point focus for the discussion and a basis for agreement or disagreement over its merits. However, any such in-depth interviewing is fraught with problems concerning power relationships. Although all participants were adults, the teacher-educator is in the role of ‘expert’ and the student may feel vulnerable and so tentative or even reluctant to say what they *truly* believe. However, Open University students are known for the usually straightforward way that they press to get ‘value for their money’ and it is also significant that in **Publication 5**, p. 153 ‘Student 3’ from Canada was able to say about the graphical tool “You asked us to be brutal, so here goes!”

Questionnaires

Questionnaires were not often used in the mix of methods used across the publications but there are two exceptions. One was paper-based and is explained extensively in **Publication 1**. The questionnaire gave the students time to think about issues which were then followed

up in an interview. The quantitative methods of information from the Heads of Physics Departments could be discussed and compared with the opinions of the students. Again, the different methods could be triangulated to improve the validity of the evidence collected. The second example of the use of a ‘questionnaire’ was carried out by telephone. In April 2005, the market research firm NOP Social and Political was commissioned to investigate the take up of TeachandLearn.net (T&L) from both those who had subscribed and from those reluctant to do so. A 10-minute questionnaire using a ‘Computer Aided Telephone Interview’ technique was conducted with teachers in schools who had responsibility for teacher professional development. The outcomes are considered in detail in Part 3.1b, and the results are shown in Tables 7 and 8.

Mixed Methods

In bringing together the quantitative and qualitative approaches to data collection I was able to triangulate evidence. In **Publication 1**, for example, as part of the evaluation of the innovative two-year PGCE, I wanted to collect the views of the students and the college lecturers but also those of experienced physics teachers in schools. Postal questionnaires were used to collect information from 21 out of 26 Heads of Physics Departments of schools in the Swansea area. The students’ and lecturers’ views were followed up with structured interviews recorded on tape and later transcribed. Classroom observation was undertaken in a rather ‘impressionistic’ way using the Swansea Education Department observation categories of: Lesson Planning, Teaching Techniques, Class Control and Organisation and Pupil Activity (See **Publication 1**, Appendix 2). McCormick and James (1987) contend that any method that illuminates the issue can be helpful. The mixed methods approach used in **Publications 1, 2, 4 and 14** all use a ‘concurrent’ design. As Biesta (2021, p. 188) notes, in a concurrent design, qualitative and quantitative elements occur within the same study and the different

elements of evidence can be triangulated so coming together to support and confirm the validity of the findings. This gave confidence that the data from these studies provided valid responses to Research Questions 1-3.

The extensive evaluation study in 1988 presented as **Publication 1** acted as an initial exploration and verification of the basic mixed methods research techniques that were needed for *all* the evaluation studies of teacher-education programmes presented in the publications for this thesis. This set the pattern both for addressing the Research Questions and also for exemplifying the international impact of the publications including its final coming together in the work on STEM teacher education shown in **Publication 16** in 2021.

Ethical Considerations

In all cases of reported interviews in the publications in this thesis, the names of the participants have been changed. All respondents took part in the studies willingly and were keen to help in the ‘Research’ to improve the ‘Developments’ that they were a part of or that would be taken into consideration in future teacher-education products. They knew they could withdraw at any time, but no one did so. In all cases, where relevant, the institutions and settings within which the research was set (and which might therefore have an interest in the research) were also involved in the process of gaining consent. All in-depth interviews were audio recorded, and the participants were sent the transcript. If they were then, or later, unhappy about a point that they had made and wanted it deleted from the transcript, their wish was carried out. If there was a physical outcome of the research, such as a report like **Publication 1**⁹, all participants were given access to it. In most cases, however, the outcome

⁹ Banks, F. R.J. (1988) *A Preliminary Evaluation of the Two-Year PGCE and Diploma in Physics*, Swansea: University College of Swansea, Education Department Research Monograph No. 1.

of the research was the development of the current or next teacher education product as part of my R&D approach.

The power relationship between student-teacher and teacher-educator is an important consideration, as is the need to minimise harm through embarrassment in the outcomes of observed lessons or insensitive reporting of examples in the publications.

BERA (2018, p. 13) counsel that:

Researchers who are researching their own practice should also consider how to address any tensions arising between collecting data for different purposes – for example, using for research purposes data collected for evaluation purposes, or vice versa.

This was particularly important, for example, in the interviews following classroom observations and feedback of the lesson of ‘Geoff and Alun’ in Section 2.1b. Assurances were given about the interview not affecting their assessment, and they had already seen the notes about the observed lesson. As for every in-depth interview, they had access to their audio recording.

BERA (2018, p. 6) emphasise:

Individuals should be treated fairly, sensitively, and with dignity and freedom from prejudice, in recognition of both their rights and of differences arising from age, gender, sexuality, ethnicity, class, nationality, cultural identity, partnership status, faith, disability, political belief or any other significant characteristic.

In discussing this issue, Hammersley (2021, pp. 58-59) says:

One type of harm that can arise from research is damage to people's reputations, perhaps because they are reported as doing things that are at odds with what they say they do, with their declared principles, or with legal requirements.

These points were borne in mind throughout the studies but were particularly relevant in work in Bangladesh as reported in **Publication 12**¹⁰. Bangladeshi colleagues were involved in gaining approval and helping with teacher feedback after any classroom observations.

Care has been taken in all publications that, as far as possible, the views expressed by participants in the research, and the contexts in which they took place, have been generalised at a level that avoids the specific identification of individuals.

1.3 Biographical background

In 2009 I gained a personal chair as the Professor of Teacher Education at The Open University. I am a graduate in Physics with Education who, as a secondary schoolteacher in different high schools in England and in Wales, taught all the separate STEM subjects (Science, Technology, Engineering (specifically Engineering Science) and Mathematics). To give some background to my standpoint in relation to my own teacher professional knowledge and to indicate the rationale as to the selection of the publications, I now lay out experiences that have contributed to the formation of my own personal subject construct. This biographical background may also give some insight into my 'identity' as a teacher which has led to my personal view of what constitutes 'good' teaching and my belief in the

¹⁰ Banks, F. (2011) 'Technological Literacy in a Developing World Context: The Case of Bangladesh' in de Vries, M. (ed.) *Positioning Technology Education in the Curriculum*, Sense Publishers: Rotterdam, pp. 219-226.

purposes of the STEM curriculum, and ultimately why I wanted to teach it and to engage in Teacher Education.

On 9th August 2021 I received the following e-mail from Jonas Hallström, Professor of Technology Education at Linköping University, Sweden about a book to be edited by him and Professor P. John Williams of the Science and Maths Education Centre, Curtin University, Australia. (Hallström and Williams, 2022):

“John Williams and I are currently editing a book for Springer about teaching and learning about technological systems. It so happens that we think it would be very suitable to include a foreword by a prominent researcher in our technology education community – and we were thinking of you! You have a good overview of the field and authority in D&T/technology education, so would you consider contributing to our book with a short foreword?”

I accepted the offer, but the journey to be considered internationally as ‘a prominent researcher in our technology education community’ began 50 years ago.

At the age of 18 I had decided that I would become a teacher of physics and was accepted on the undergraduate course at the University of York to study Physics with Education. This was split two-thirds physics and one-third education and I began the course in October 1972.

York was to be a site for the first Open University summer-school for the technology foundation course T100 and for the first second-level course in electronics. I worked during the summer vacation in 1973 as a laboratory technician setting up experiments for the students and mending faulty equipment such as the electronics home practical kit known as the ‘Generatorscope’ a combined power-supply, signal generator and oscilloscope. During

the early days of the Open University, schoolteachers were a significant proportion of the student body as those that had a diploma in education could use that qualification as ‘advanced standing’ counting towards their Open University degree. On graduation with a degree, they would gain a significant pay-rise. It has been said that teachers were a major boost to both the coffers and the reputation of the fledgling university. This work with teachers at the Open University summer schools was the first step towards becoming a teacher educator.

I stayed on at the University of York after graduating, and in October 1975 I began the Certificate in Education postgraduate course (PGCE) specialising in teaching physics (main) and mathematics (subsidiary). As I had studied undergraduate education, I did the ‘special’ PGCE course which gave a long practicum of two consecutive terms and I was placed at Sir Leo Schultz High School, Hull. This 13-18 school was well-equipped but even in 1975 was still developing as a new ‘comprehensive school’ and, unusually, was governed by the staff themselves through a common room committee. As was usual, all the science staff taught some ‘general science’ as well as their science specialism. As a pupil, I had attended a comprehensive school but mine was opened in 1955 and was rather more disciplined. Currently (2022) on Facebook there is a group page titled “I survived Sir Leo Schultz High School Hull”. This perhaps underlines that it was not an easy school for a novice teacher to begin their training. Although constructed as a new building, it only ‘survived’ itself from 1966 to 1986 when it was then closed by Hull council.

I was subsequently employed as a schoolteacher in two other schools in Hull where I was able to gain some sixth form experience teaching Engineering Science as well as lower-school science and upper-school physics. During these years, through my work as a

technician for the Open University summer school, I was offered a different job as an Open University summer school demonstrator for T100. This involved some teaching by supporting a tutor in the laboratories which I did for two to three weeks every summer from 1977 to 1981. In December 1981 I moved to teach at a school in Wales as Head of Physics. As it was a school of just 420 pupils, I was the *only* full-time teacher of physics and I taught science and physics across the whole age range 11 to 18. I introduced a new A level syllabus which included electronics and other aspects of technology. Pleasingly this change was supported by the headteacher as such an innovative syllabus was not then offered by the Welsh examination board (WJEC) and so the new examination had a political dimension too.

In early 1982 I was asked to become the Open University (OU) tutor-counsellor for the mid Wales students on T100. This is now termed an ‘associate lecturer’ but in the 1980s, the job was to tutor OU students in their first compulsory foundation course and then serve as their counsellor advising and supporting them on their journey towards a degree. This supported open-learning model was the basis of the success of the OU. I was an associate lecturer in Wales from 1982 to 1991 working on the original and subsequent technology foundation courses T100, T101 and T102, but I also taught on ET217, a course for schoolteachers of technology, and on the Masters course ES281 ‘Science Education’. Working with teachers on a summer school for ET217 was an opportunity to jointly produce teacher support materials for the new design and technology national curriculum. The materials were submitted to the Curriculum Council for Wales in Cardiff, and I was subsequently invited to be a member of a group producing non-statutory guidance for design and technology teachers (Banks *et al.*, 1990).

In 1985, while a schoolteacher in Powys, Wales I was asked to attend a term-long residential course at Nottingham Polytechnic in the teaching of Technology. This was to enable me to become a supporting teacher on a converted bus which toured different counties to provide four practical week-long courses in the teaching of Technology to a pair of teachers from each school in the local area: one a science teacher, the other a teacher of Craft, Design and Technology (CDT) which in most schools then largely emphasised the ‘Craft’ element in the title, and CDT was often interpreted as ‘woodwork and metalwork’ (See **Publication 9**¹¹). Technology was seen as a more creative and modern subject emphasising design of electronic and pneumatic systems and computer control. I introduced Technology as a subject into the school where I was teaching and so, over my 11 years as a schoolteacher across different schools I had taught classes in all the contributory STEM subjects: Science, Technology, Engineering and Mathematics.

In 1986 I was seconded by Powys Local Education Authority (LEA) to be an Advisory Teacher. This was to support primary school teachers with the introduction of science into the curriculum. This was direct practical work in teacher-education in schools, and it also gave me the opportunity to ‘enliven’ the place of science in the primary curriculum as I toured schools with an ‘inflatable planetarium’ to talk about the once-in-a-lifetime return of Halley’s Comet and, later, to tour local libraries with hands-on exhibits from the TECHNIQUEST science museum in Cardiff. I wrote the teacher handbooks *Astronomy: A Guide for Teachers* (Banks, 1986) and *Ideas from TECHNIQUEST for Key Stage 2* (Banks, 1989).

¹¹ Banks, F. R.J.(1996) ‘Approaches and Models in Technology Teachers’ Education: An Overview’, *Journal of Design and Technology Education*, Vol. 1 (3), pp. 197-211.

In 1987 I became a lecturer in Physics Education at the University College of Wales, Swansea to work on an innovative two-year PGCE where students studied physics and the pedagogy of teaching physics integrated over the two years. My first research in education was a formal evaluation study of this two-year course where a research and development (R&D) methodology was adopted (See **Publication 1**¹²). The outcome of the evaluative study fed back into the development of the course. I later moved to be the physics methods tutor for the more conventional one-year PGCE. In-service work with teachers was part of the duties and I ran courses for local physics teachers and for other teachers (such as biology teachers) who due to a shortage were often asked to teach physics. I worked with a group of physics teachers to produce a resource-pack of *Experimental Investigations for Post-16 Physics* (Banks, 1992). In 1990, I graduated with a Masters in Arts (Education) from The Open University and with that positive experience, I persuaded the Education Department at Swansea to offer masters level distance-learning modules. With two colleagues I wrote the first such module *Assessment in Science* (Banks, Parkinson and Woodward, 1991).

In 1991 the Open University gained permission to offer the first distance-learning PGCE course and I applied to work on the development of the new science line. I was called to interview, and I thought that the letter was a mistake as I had been invited to an interview to be the lecturer to develop the new *Technology* line. It was no mistake. I was interviewed for a post that I had not applied for and on Christmas Eve 1991 I was offered the post to write the new PGCE in Technology. I joined The Open University as a full-time member of staff in April 1992, sixteen years after first working at an OU summer school. The first task was to develop a 'reader' for the course – an edited collection of existing and specially authored

¹² Banks, F. R.J. (1988) *A Preliminary Evaluation of the Two-Year PGCE and Diploma in Physics*, Swansea: University College of Swansea.

articles to be published by Routledge (Banks, 1994). As Open University students studying at home did not have access to an academic library, the reader was intended to put in one book the articles a lecturer would place on a reading list. *Teaching Technology* became one of the first academic books available for PGCE students about this new school subject and so was widely adopted as a key text both in the UK and internationally. The Open University PGCE (OUPGCE) was presented in 1994 and as well as supporting the course in presentation, I also became the staff-tutor for the PGCE in Wales (See **Publication 10**¹³).

During the preparation of the OUPGCE, initial course plans were shared with colleagues from other teacher education institutions. It took many years for The Open University to be accepted as a university with standards the same as any other, initially being ridiculed by senior politicians such as the then Chancellor of the Exchequer, Iain Macleod MP as ‘blithering nonsense’ (Macleod, 1969). In a similar way the OUPGCE was ridiculed as ‘becoming a teacher by sitting at the kitchen table’. The strong argument against an OUPGCE was that ‘proper’ teacher education was developed through discussion, the sharing of teaching ideas, resources and experiences and the essential support of student colleagues. How could that possibly be done by distance-learning? The resource envelope provided by about 1200 student teachers every year was such that they could be given home use of a personal computer. At a meeting to discuss what classroom software should be provided with the computer, I successfully argued that instead of providing software which would be rapidly obsolete, we should rather provide each student with a modem. This would facilitate students linking up with one another and enable them to discuss on-line the course issues, share teaching resources and offer mutual support. Using the message-board program

¹³ Banks, F. and Shelton Mayes, A. (1998) ‘High quality and new standards: an open learning contribution to the improvement of pre-service teacher education’, *Paper at AERA*, San Diego, USA.

‘FirstClass’, the OUPGCE became the pioneer in using such new technologies for the education of teachers. The course was launched in 1994, a year before *Internet Explorer*, four years before *Google* and a decade before *Facebook* (See the discussion on developing new technologies for teacher education in Section 3.1b p111).

The Office for Standards in Education (OfSTED) inspected the OUPGCE over the first two years. They were interested in the model for initial teacher preparation which put the subject knowledge support and the assessment of the teacher in the hands of the school through a school subject mentor, albeit supported in their judgements by a senior school colleague. Marking of assignments and support at day-schools was provided by a part-time tutor appointed by The Open University but these were generalists, not subject specialists, as were the local full-time Staff Tutors. As there were inevitable teething problems, it was a special moment when in 1995 for the first time The Open University won the Queen’s Anniversary Higher Education Award, and it was for the OUPGCE. It was also gratifying that the *flexible* OUPGCE received the highest ‘Outstanding’ grade in September 2010 from ETI in Northern Ireland and also from OfSTED in March 2011.

The new model for the education of teachers at scale was of great interest internationally. A Centre for Research in Teacher Education (CReTE) was established using a research and development approach which built on innovation and the two-year investment in the preparation of the OUPGCE, and its evaluation. The members of CReTE worked on how open and distance learning could address the world-wide shortage of teachers (Banks, Hobbs and Moon, 1997, Banks *et al.*, 2007, Banks, Moon and Wolfenden, 2009). Distance Education in-service workshops for teachers and teacher educators were conducted in Egypt, Ethiopia, Ghana, India, Malawi, Sudan and South Sudan. This led to the major in-service

initiative ‘Teacher Education in Sub-Saharan Africa’ (TESSA) which was also the recipient of the Queen’s Anniversary Higher Education Award in 2009, and later TESS-India (‘Teacher Education through School-based Support’). In both programmes the materials were made freely available under a ‘creative commons’ copyright licence. CReTE also took the lead in promoting the use of new technologies in UK classrooms through the ‘Learning Schools Programme’ where, in 2000 through a collaboration with the computer firm Research Machines, teachers were shown how to make better use of the computer in their classroom (Banks, 2001). Later, in collaboration with the BBC a professional development website called ‘TeachandLearn.net’ was established (Banks, 2003). I was the director of TeachandLearn.net during its final year from 2004 and director of CReTE from 2005-2007, taking over the directorship of International Development in Teacher Education from 2007 to 2013. The TESSA model was developed for English in Action where micro-SD cards were provided for mobile phones which provided exemplar video lessons that, along with print materials and day schools, gave in-service support to teachers of English in Bangladesh (Shohel and Banks, 2010; Shohel and Banks, 2012), and for TESS-India developments too (Banks, 2014).

The R&D methodology and developing ideas through CReTE helped with the creation of courses in technology. I began an evaluation study of the technology line of the OUPGCE to discover what aspects of the course the students found difficult and, more significantly, what their life and employment experiences brought to the school teaching of technology (**Publication 2**¹⁴, Banks, 1997). In 1994, I became the joint author with Professor Bob McCormick of the course E650 ‘Design and Technology in the Secondary Curriculum: A

¹⁴ Banks, F.R.J. (1996) ‘Developing Professional Knowledge During Initial D&T Teacher Education’, *Journal of Design and Technology Education*, Vol. 1 (2), pp. 175-178.

Professional Course for Teachers' which built upon that understanding. Sponsored by the Department of Education, it focused on two aspects of teaching that were considered to need particular development: 'Designing and making' and 'Teaching and learning control concepts'. The funds from this initiative enabled me to start to regularly attend a series of the prestigious conferences for technology educators known as PATT - 'Pupil's Attitude Toward Technology'. The conference organisers are based in the Netherlands, holding a conference there every two years. By 1993, the themes of the conferences had moved away from considering pupils' attitudes to technology to encompass a range of topics and I presented refereed papers at ten conferences from 1993 to 2012, for example, **Publication 3**¹⁵ which used a framework for subject knowledge and 'minimum competences' needed by technology teachers that was developed by the technology subject association DATA (Banks *et al*, 1995). I was a member of the panel that designed the framework and the new standards for DATA. At these conferences delegates would often mention the international impact of the OU reader *Teaching Technology* and over the years I would be approached to contribute 19 chapters to books concerning the teaching of technology in schools. Further, I was asked to run workshops for technology teacher trainers in Australia, Argentina, Egypt, Jordan and South Africa and also for Iraqi mathematics teachers, science teachers in Egypt, and physics teacher trainers for the African Virtual University in Nigeria.

During 22 years as a member of CReTE I had taught PGCE students, in-service teachers and teacher-educators across 12 countries in all the contributory STEM subjects: Science, Technology, Engineering and Mathematics. In 2006 I became academic director of 'OpenLearn' and was instrumental in obtaining from the STEM and other OU faculties

¹⁵ Banks, F. (1997) 'Assessing Technology Teacher Professional Knowledge' *Proc. of PATT-8 Conference*, Scheveningen, Netherlands. pp. 240-252.

materials for the free learning resources from the Open University that were used extensively world-wide by parents home-schooling during the Covid-19 lockdowns (<https://www.open.edu/openlearn/>).

In 2001, in collaboration with Dr David Barlex, the then director of the Nuffield Design and Technology Project, my work on what life and employment experiences contributed to PGCE students' professional knowledge was extended to include students at Brunel University (Banks and Barlex, 2001). This small study acted as a pilot for an international collaboration into the study of teacher professional knowledge. Some delegates at PATT came together to create a world-wide study that brought the ideas of professional knowledge explored by CReTE, re-configured into a Graphical Tool, directly to bear in an international study looking at Developing Professional Thinking for Technology Teachers (DEPTH). I was group convenor of technology teacher educators from four universities in the UK, two universities in New Zealand, and others from Australia, Canada and Finland who each conducted a similar study using the graphical tool resources in their own country (**Publications 5¹⁶ and 6¹⁷**).

David Barlex was a schoolteacher of Chemistry who became highly involved in the teaching of technology in schools and the development of technology teachers through the production of curriculum development materials for the Nuffield Curriculum Centre. I was a schoolteacher of Physics who became involved in teaching technology and engineering in schools and the development of technology teachers through innovative pre-service and in-

¹⁶ Banks, F., Barlex, D., Jarvinen, E-M, O'Sullivan, G., Owen-Jackson, G. and Rutland, M. (2004) 'DEPTH - Developing Professional Thinking for Technology Teachers: An International Study', *International Journal of Technology and Design Education*, Vol. 14 (2), pp. 141-157.

¹⁷ Banks, F. (2008) 'Learning in DEPTH: Developing a Graphical Tool for Professional Thinking for Technology Teachers', *International Journal of Technology and Design Education*, Springer, Vol. 18 (3), pp. 221-229.

service materials at the Open University. Our common biographies led us to become interested in the school teaching of the STEM subjects and how we could support teachers to meet the challenge of introducing, supporting and maintaining STEM in the secondary school. **Publication 16**¹⁸ (2021) is the outcome of the combination of our joint experiences over the last 50 years as the changing context of technology and STEM curriculum has evolved, and therefore this final selected publication reflects the consequent development of our personal subject constructs during that time.

1.4 The changing context of Technology and STEM education

This section details the changing ‘Specified Curriculum’ for Technology and for STEM. From the late 1960s, Technology as a problem-solving process embracing topics such as electronics, pneumatics and mechanisms, and using construction kits like Lego and Meccano (for example), was commonly taught in the later years of the larger secondary schools. This rather ‘Applied Science’ view of the subject, appealing strongly to boys, was promulgated vigorously in the early 1980s with funding from the Department of Employment as part of the Thatcher government’s drive to make the school curriculum more vocationally orientated: the so called ‘Technical and Vocational Education Initiative’ (TVEI) (see **Publication 15**¹⁹). In-service training was given to teachers of Science and of Craft (usually drawn from the same school), in order to continue the more general development of both school subjects: Craft to embrace new aspects of designing and Science to have a better connection with scientific contexts outside the school laboratory.

¹⁸ Banks, F. and Barlex, D. (2021) *Teaching STEM in the Secondary School: Helping teachers meet the challenge*, (Second edition) London: Routledge.

¹⁹ Banks, F. (2013) ‘Innovation Education through Science, Technology, Engineering, and Math (STEM) Subjects: The UK Experience’ in Shavinina, L.V. (ed.) *The International Handbook on Innovation Education*, London: Routledge, pp. 557-569.

In England and Wales, a compulsory National Curriculum was introduced in 1988 for Mathematics and Science, and in 1990 for Technology, following a consultation exercise. The final published Technology curriculum document was much more focused than the initial consultative report had been, on Technology as a development of Craft, Design and Technology (CDT) with new areas such as food technology and textiles as ‘material areas’. More significantly, however, the focus was on Technology as a *process*. It had four attainment targets:

- Attainment target 1 – Identifying needs and opportunities
- Attainment target 2 – Generating a design
- Attainment target 3 – Planning and making
- Attainment target 4 – Evaluating

This process-based curriculum was difficult to implement as it was also suggested that a wide range of teachers become involved. The implications for initial teacher education were that there was a new need for teachers to offer a breadth of subject knowledge, but also a specialist area too (See **Publication 3**²⁰ and **Publication 9**²¹).

After only two years, The Engineering Council produced a damning report by Smithers and Robinson which declared that ‘Technology in the National Curriculum is a mess’, and that the process-based format of the curriculum was not sufficient (Smithers and Robinson, 1992).

In 1995 a new version of the curriculum for England and Wales gave a clearer steer to what Design and Technology was, and the main pedagogical strategies that should be employed:

²⁰ Banks, F. (1997) ‘Assessing Technology Teacher Professional Knowledge’ *Proc. of PATT-8 Conference*, Scheveningen, Netherlands, pp. 240-252.

²¹ Banks, F. R.J. (1996) ‘Approaches and models in technology teacher education: an overview’, *Journal of Design and Technology Education*, **1** (3) 197-211.

Pupils should be given opportunities to develop their design and technology capability through:

Assignments in which they design and make products, focussing on different contexts and materials and making use of:

- Resistant materials.
- Compliant materials and/or food (DMAs- Design and Make Assignments).
- Focused practical tasks (FPTs) in which they develop and practice particular skills and knowledge.
- Activities in which they investigate, disassemble and evaluate familiar products and applications (IDEAS) (National Curriculum DFE/WO,1995, p. 6).

Around this time, the Teacher Training Agency (TTA) for England was interested in regulating the standards achieved by teachers entering the profession by specifying for all subjects what competences a teacher should be able to demonstrate. In addition to teaching standards, the TTA specified the subject knowledge needed to be able to satisfactorily teach the core subjects of English (mother tongue), Mathematics and Science. The subject association for Design and Technology (DATA) thought this level of specificity should apply to Design and Technology too (Banks *et al.*, 1995). So from 1994/5 the curriculum content in schools and in teacher training institutions in England was very much clearer.

A consequence of a prescribed curriculum is the potential danger that ideas and methods stagnate. In 2000 the school Design and Technology curriculum was again revised specifying

just one attainment target (Design and Technology), and a new and much simplified standards document for initial teacher education courses was introduced in 2002. Consequently, in 2003 new subject knowledge expectations for teachers entering the profession were suggested by DATA. The revised school curriculum strongly promoted new technologies – in particular the use of CAD/CAM software packages.

More recently, a key development in England (which has also been seen in other countries) is a move away from detailed prescription of what should be taught to a slimmer national curriculum. Coupled with this have been developments in the school system including some with a particular curriculum emphasis: ‘City Technology Colleges’, ‘Academies’ and ‘Free Schools’, which are all non-profitmaking, state-funded schools that are free for pupils to attend but are not subject to *local* government scrutiny (although they are subject to inspection by the Office for Standards in Education) and may opt out of the national curriculum. The creative curriculum in general has suffered in recent years due to the introduction of the English Baccalaureate (EBacc). The EBacc is restricted to English, Mathematics, the sciences, history or geography and a language. Students may take other subjects including Music, Art or D&T but these do not count in the all-important ranking of schools. Secondary schools are measured on the number of pupils that take GCSEs (examinations usually taken at 16) in these EBacc subjects and in how well their pupils do. The downplaying of Design and Technology in this formal way has reduced the number of pupils electing to study the subject after the age of 14. But as the subject association for Design and Technology teachers point out, for students in the lower High School aged from 11 to 14 years:

As students progress through this phase, they may be given the opportunity to focus on specific aspects of the subject such as product design, food technology,

engineering, systems and control, electronics, textiles and graphics. However, at its core is creativity and imagination. Students learn to design and make products that solve genuine, relevant problems within different contexts whilst considering their own and others' needs, wants and values. To do this effectively, they will acquire a broad range of subject knowledge and draw on additional disciplines such as mathematics, science, engineering, computing and art (DATA, 2021).

In Northern Ireland the more restricted subject knowledge encompassed by Technology and Design has meant that the subject has been more stable. The subject 'Technology and Design' is intended:

to enable all pupils to become confident and responsible in solving real life problems, striving for creative solutions, independent learning, product excellence and social consciousness (Technology and Design Ministerial Report DENI 1991, p. 15).

There are 9 curriculum areas in Northern Ireland, with the Technology and Design strand as part of the Science and Technology area. There is a strong 'applied science' thrust and at the age of 14 pupils learn about:

- design, communication, manufacturing and control.

This has been unchanged since 2000 (CCEA, 2000). Technology and Design encourages pupils to develop creative thinking and problem-solving skills by evaluating design proposals and selecting and using materials that are fit for purpose. The intended learning outcomes are:

- demonstrate practical skills in the safe use of a range of tools, machines and equipment; creativity and initiative when developing ideas and

following them through and self-management by working systematically, persisting with tasks, evaluating and improving own performance.

- research and manage information effectively to investigate design issues, using Mathematics and ICT where appropriate.
- show deeper understanding by thinking critically and flexibly, solving problems and making informed decisions, using Mathematics and ICT where appropriate.
- work effectively with others.
- communicate effectively in oral, visual (including graphic) written, mathematical and ICT formats showing clear awareness of audience and purpose (CCA, 2022).

These learning outcomes are achieved mainly through the designing and making of products in resistant materials, ‘product design’ or ‘systems and control’ where the emphasis on electronics is unusual and more sophisticated compared to other areas of the UK.

Scotland saw a similar interest in the development of Technology in terms of structures, mechanisms, electronics and so forth in the rise of the subject ‘Technological Studies’ in 1988. As in England, this was promoted by funding available under the Technical and Vocational Education Initiative (TVEI).

In 2011, Scotland implemented the ‘Curriculum for Excellence’ (CfE) which lacks the prescription of the curriculum in England and Northern Ireland, and, like those in Wales, Scottish schools are encouraged to design their own curriculum to suit local needs. However, CfE includes an area called ‘Technologies’ which aligns with creative, practical and work-

related activities (See **Publication 11**²²). As in many countries, however, the examination system has a hold on the extent of the freedom schools have for curriculum design and there are two examinations.: ‘Design and Technology’ and ‘Design and Manufacture’ that are of particular interest.

Design and Technology - The aims of the course are to enable learners to:

- develop skills in producing and interpreting sketches, drawings and diagrams, practical model making and construction and in testing and simple evaluation of models.
- apply safe working practices in a workshop or similar environment
develop knowledge of basic engineering ideas.

Design and Manufacture - The aims of the course are to enable learners to:

- develop skills in the design and manufacturing of models, prototypes and products, knowledge and understanding of manufacturing processes and materials and an understanding of the impact of design and manufacturing technologies on our environment and society.

Also of interest in Scotland is a number of so-called practical courses such as ‘Practical Electronics’. The aims of this course are to enable learners to develop:

- knowledge and understanding of key concepts in electronics and apply these in a range of contexts... and a range of practical skills in electronics, including skills in analysis and problem solving, design skills, skills in the

²² Banks, F. and Williams, P. J. (2013) ‘International perspectives on technology education’ in Owen-Jackson, G. (ed.) *Debates in Design and Technology Education*, London: Routledge, pp. 31-48.

safe use of tools and equipment, and skills in evaluating products and systems (SQA, 2022).

Interestingly in Scotland there are also popular courses simply called ‘Practical Skills’ available in Woodworking, Metalworking and Cookery.

In April 2019 a curriculum was launched in Wales built around ‘areas of learning and experience’. Known as a Curriculum for Wales 2022, the need for a coordinated approach is built into the curriculum design. For example, one area of learning is ‘Mathematics and Numeracy’ and another ‘Science and Technology’, and the curriculum stretches across the whole school age range 3 to 16. ‘Science and Technology’ includes the following:

Design thinking, and engineering offer technical and creative ways to meet society’s needs and wants:

By applying their experiences, skills and knowledge, learners can design and shape innovative engineered solutions. Being part of a user-centred design process will encourage them to use creativity to develop ideas, manage and mitigate risks, and minimise complexities. When engineering products, services and systems, they will need to understand and control the interactions between materials, structures, components and users. The application of engineering processes allows learners to develop accuracy, precision, dexterity and craftsmanship. By designing and engineering outcomes in response to needs and wants, learners can become enterprising problem solvers (Hwb, 2022).

From the early introduction of Technology as a new area of learning in the 1990 National Curriculum for both England and Wales, and in the equivalent subjects developing around the

world, teachers were encouraged to engage in the design and making of authentic products (see **Publication 15**²³ and **Publication 16**²⁴Chapter 1). Often projects developing new real-life products do not respect the traditional subject boundaries of science, mathematics and technology which are taught in subject ‘silos’ but a pupil will need to draw on the different STEM subjects.

This is recommended in the English national curriculum as we can see by looking at aspects of the statements about the STEM subjects published in July 2013 (my italics):

Science:

A high-quality science education provides the foundations for understanding the world through the specific disciplines of biology, chemistry and physics. Science has changed our lives and is vital to the *world’s future prosperity*, and all pupils should be taught essential aspects of the knowledge, methods, processes and uses of science.

[...]

Design and Technology:

Design and Technology is an inspiring, rigorous and practical subject. Using creativity and imagination, pupils design and *make products that solve real and relevant problems* within a variety of contexts, considering their own and others’ needs, wants and values. They acquire a broad range of subject knowledge and draw on disciplines such as mathematics, science, engineering, computing and art. [...]

²³ Banks, F. (2013) ‘Innovation Education through Science, Technology, Engineering, and Math (STEM) Subjects: The UK Experience’ in Shavinina, L.V. (ed.) *The International Handbook on Innovation Education*, London: Routledge, pp. 557-569.

²⁴ Banks, F. and Barlex, D. (2021) *Teaching STEM in the Secondary School: Helping teachers meet the challenge*, (Second edition) London: Routledge

Computing

A high-quality computing education equips pupils to use computational thinking and creativity to understand and change the world. *Computing has deep links with mathematics, science, and design and technology*, and provides insights into both natural and artificial systems. The core of computing is computer science, in which pupils are taught the principles of information and computation, how digital systems work, and how to put this knowledge to use through programming. [...]

Mathematics

Mathematics is a creative and highly inter-connected discipline that has been developed over centuries, providing the solution to some of history's most intriguing problems. *It is essential to everyday life, critical to science, technology and engineering, and necessary for financial literacy and most forms of employment*. A high-quality mathematics education therefore provides a foundation for understanding the world [...]

The argument that STEM subjects need to support and draw on each other is clearly illustrated. How the separate subjects can work together in practice is not spelled out in the national curriculum documents. However, consideration of how teachers can be helped to meet that challenge is the rationale for **Publication 16**²⁵. There are a number of approaches where the usually separate subjects can come together for the benefit of pupils.

²⁵ Banks, F. and Barlex, D. (2021) *Teaching STEM in the Secondary School: Helping teachers meet the challenge*, (Second edition) London: Routledge.

A coordinated approach

In a properly coordinated approach, teachers in each subject become familiar with the work carried out in the others and plan their curricula so that the *timing* of topics within each subject is sensitive to others' needs and taught in a way that supports the pupils' developing understanding, rather than one that causes confusion. For example, proficiency with the use of measuring in millimetres, and ways of collating data from respondents, would benefit technology if covered in lower school mathematics; and if electricity is explained using similar analogies and terminology in both technology and science, the pupils' developing ideas can be reinforced.

A collaborative approach

In a collaborative approach, some activities within each subject are *designed and planned by teachers working together* to establish an effective relationship. For example, in developing teaching resources for the curriculum in Scotland, Education Scotland created as part of a STEM initiative an interdisciplinary unit of work concerned with renewable energy (ES, 2018). Pupils undertake four 'learning journeys': 'From fossil fuels to wind', meets some of the science requirements, 'Wind, wave and tidal' meets some of the technology requirements, and 'Calculating the wind', meets some of the mathematics requirements of the curriculum with links across to science and to technology. At the end, in 'This island is going renewable', pupils are challenged to make the case for the use of renewable energy by the small island community.

The integration of STEM subjects

There are two ways of considering the integration of the STEM subjects. One is getting synchronous inputs from a range of staff for an off-timetable event or project. Here, all the educators support the activities through team-teaching and pupils turn to a particular member of staff for advice and support when they are available. Around the world, pupils of all ages take part in competitions and challenges or attend workshops in science museums and higher-education institutions. In Taiwan, for example, robot-building from using Lego through to full combat ‘robot wars’ models are a common out-of-school activity. In Japan, ‘STEMinars’ occur early in the school year in which pupils are encouraged to attend a university for an intensive one-week ‘deep dive’ into a STEM area of interest.

The second way is a full integration of the STEM subjects in school so that one teacher follows a themed project across a number of lessons, as is often the case in primary schools. Adopting this at the secondary level assumes that considerable expertise is available in the one teacher, or that resources are needed for a team-teaching approach. However, Science and Design and Technology, for example, are significantly different from one another and it is difficult to ensure that there is a true integration of subjects as equals and that one of the subjects does not dominate and subsume the other. Integration has been successful in Belgium and in Israel (see **Publication 11**²⁶).

In my research on the professional knowledge of science and technology teachers, I discovered that their subject knowledge, the teaching strategies they use (pedagogical knowledge), and their understanding on how to transform their subject knowledge into a form

²⁶ Banks, F. and Williams, P. J. (2013) ‘International perspectives on technology education’ in Owen-Jackson, G. (ed.) *Debates in Design and Technology Education*, London: Routledge, pp. 31-48.

that supports their pupils' learning within the school context and the examination requirements (school knowledge), are equally important for successful learning in STEM.

1.5 Structure of the thesis and an overview of the publications

The interrelationship between the 16 publications centres on a research and development (R&D) approach to the education of teachers and is divided into three interlinked themes, namely Teacher Professional Knowledge, Developing Teachers of Technology, and Developing Teachers of Science, Technology, Engineering and Mathematics (STEM) in order to address the related research questions:

Research Question 1 (RQ1): What are the elements of teacher professional knowledge and what is their inter-relationship?

Research Question 2 (RQ2): In what ways can the suggested elements of teacher professional knowledge support the development of teachers of Technology?

Research Question 3 (RQ3): In what ways can the suggested elements of teacher professional knowledge support the development of teachers of STEM?

Each chapter is devoted to a theme where a research question is addressed. A consideration of the current literature from the field is first explored, followed by a section which shows how the published works presented here contribute to knowledge in that field. The rationale for the selection of each publication is as follows:

	Specified Curriculum	Enacted Curriculum	Experienced Curriculum
RQ1	Publication 1	Publication 1	Publication 1
	Publication 2	Publication 2	
	Publication 3	Publication 3	
		Publication 4	
		Publication 5	
		Publication 6	
		Publication 7	
RQ2	Publication 8	Publication 8	Publication 8
		Publication 9	
		Publication 10	
	Publication 11		
	Publication 12	Publication 12	Publication 12
	Publication 13	Publication 13	Publication 13
RQ3	Publication 14	Publication 14	Publication 14
	Publication 15	Publication 15	Publication 15
	Publication 16	Publication 16	Publication 16

Table 1: The rationale for the selection of each publication.

The published works in Volume 2 of this thesis are in the order in which they are considered.

A brief overview of the content of each of the publication listed in the above table is as follows:

Chapter 2 Theme 1: Teacher Professional Knowledge

1. Banks, F. R.J. (1988) *A Preliminary Evaluation of the Two-Year PGCE and Diploma in Physics*, Swansea: University College of Swansea, Education Department Research Monograph No. 1.

This evaluation study is an attempt to investigate whether the physics knowledge, scientific skills and teacher education provided on the innovative course are matched as accurately as possible to the requirements of new physics teachers entering the profession. The study

suggests ways in which the match between the course content and the requirements of teachers could be improved and suggests that there is a tentative link between student attitude and beliefs about teaching and eventual classroom performance.

2. Banks, F.R.J. (1996) 'Developing professional knowledge during initial design and technology teacher education', *Journal of Design and Technology Education*, **1** (2) 175-178, ISSN 1360-1431.

Through an empirical study of the teaching and personal background of 17 technology student teachers, this article seeks to identify the components which make up teachers' professional knowledge: subject content knowledge, pedagogical content knowledge, curricular knowledge, and school subject knowledge. The article summarises the teacher professional knowledge using a diagram. The article argues that such a diagram could facilitate a common understanding of teacher professional knowledge between student teachers, mentors in school, and college-based staff.

3. Banks, F. (1997) 'Assessing Technology Teacher Professional Knowledge' *Proc. of PATT-8 Conference*, Scheveningen, Netherlands, April 1997, pp. 240-251.

This paper examines the many benefits and difficulties of professional assessment of teacher competence with reference to teachers of Technology. It considers assessment of the particularly wide subject knowledge needed by technology teachers, the assessment of the school practicum by schoolteachers acting as 'mentors', and the need to consider appropriate professional qualities.

4. Banks, F., Leach, J. and Moon, B (2005) ‘Extract from “New understandings of teachers’ pedagogic knowledge”’, *Curriculum Journal*, **16** (3) 331-340, ISSN 0958-5176.

This article is the culmination of the Research and Development work begun with technology teachers in 1996 and later extended to teachers of mother-tongue English teachers in the UK. It explores two central questions for teacher education: How significant is content or subject knowledge for creative and effective teaching? What links can be made between a teacher’s knowledge and the associated pedagogic strategies to ensure successful learning? It led to a new graphical tool to explain the inter-related nature of teacher professional knowledge.

5. Banks, F., Barlex, D., Jarvinen, E-M, O’Sullivan, G., Owen-Jackson, G. and Rutland, M. (2004) 'DEPTH - Developing Professional Thinking for Technology Teachers: An International Study', *International Journal of Technology and Design Education*, **14** (2) 141-157, Kluwer Academic Publishers: Holland, ISSN 0957-7572.
6. Banks, F. (2008) ‘Learning in DEPTH: Developing a Graphical Tool for Professional Thinking for Technology Teachers’, *International Journal of Technology and Design*, Springer, **18** (3) 221-229, ISSN 0957-7572. (Guest Editor for this Special Edition of DEPTH papers).

These two articles report on the international DEPTH studies – ‘Developing Professional Thinking for Technology Teachers’. The model of teacher professional knowledge developed from the results of empirically studies of student teachers in the UK (**Publication 4**) is turned it on its head to create a ‘Graphical Tool’ to be presented to student teachers

internationally for them to complete from their personal perspective in their particular country context. The first article (**Publication 5**) reports on the use of the framework with both primary and secondary student teachers in the UK, and secondary student teachers in Canada, Finland, and New Zealand as a tool to support reflection on their own professional knowledge. The DEPTH studies discovered that the graphical tool was equally useful in helping them to become more self-aware as a technology teacher when reflecting on their practice whatever their home country across the world.

The second DEPTH article (**Publication 6**) reports on DEPTH 2 and sets out the theoretical framework for the subsequent papers in this guest edited edition of the journal. A case study from Australia joined the DEPTH 1 countries. In the second phase of the project, the line of research was developed in two ways. First, the range of participants was extended to include experienced teachers involved in in-service work connected to curriculum development. Second, the inter-relationship for pre-service teachers between their developing professional knowledge and their own ‘personal subject construct’. The article sets the other papers in the context of debates surrounding the nature and importance of teacher knowledge and the way such professional knowledge can be articulated by teachers.

Chapter 3 Theme 2: Developing Teachers of Technology

7. Banks, F. (2008) ‘Teaching Design and Technology’ in Owen-Jackson, G. (ed.) *Learning to Teach Design and Technology in the Secondary School*, (2nd Edition), London: Routledge/Falmer, pp.174-193, ISBN: 0-415-46493-5

This chapter addresses the following questions: What teaching strategies are appropriate for design and technology? How can you help pupils gain capability in design and technology? What is the best way to use the support that a technician can offer? What can you do to encourage interest and enthusiasm and ensure good behaviour? It is intended for pre-service design and technology teachers and draws on research into good practice.

8. Banks, F. (2009) 'Research on Teaching and Learning in Technology Education' in Jones, A. and de Vries, M. (eds.) *International Handbook of Research and Development in Technology Education*, Sense Publishers: Rotterdam, Netherlands, pp. 373-390, ISBN:978-90-8790-877-5.

This chapter considers the types and approaches of research studies that have been conducted in the period where technology has gained in popularity across the world as a general subject for all pupils. It looks at empirical and theoretical works, and some which are offering a polemic, addressing the following areas: The development of the subject of school technology curriculum; pupils' learning in technology; teachers' pedagogy in teaching technology.

9. Banks, F. R.J. (1996) 'Approaches and models in technology teacher education: an overview', *Journal of Design and Technology Education*, **1** (3) 197-211, ISSN 1360-1431.

This article gives an overview of the different models and approaches to technology teacher education. Many of the issues which shape the requirements for professional development are common to the different teacher education structures that exist, and the need to improve the

quality and quantity of technology teachers is shared by all countries. Standing outside any one country's programme may enable a teacher educator to identify novel solutions to common problems. A framework for analysis which may be applied to a range of courses, both pre-service and INSET is presented. Both traditional and new approaches to the education of technology teachers are considered.

10. Banks, F. and Shelton Mayes, A. (1998) 'High quality and new standards: an open learning contribution to the improvement of pre-service teacher education', *Paper at AERA, San Diego, USA*. April 1998.

This paper, drawing on research and development relating to the Open University's Postgraduate Certificate in Education (OUPGCE), considers how open and distance learning programmes are evolving quality assurance systems and procedures across a range of programme elements, including assessment of student teachers. In particular, it explores how high-quality provision and outcome standards of students are assured on a high volume, highly dispersed programme, with annually over 2000 school-based contexts for practice.

The developmental journey from the first paper-based OUPGCE to the on-line *flexible* PGCE is also explored here.

11. Banks, F. and Williams, P. J. (2013) 'International perspectives on technology education' in Owen-Jackson, G. (ed.) *Debates in Design and Technology Education*, London: Routledge, pp. 31-48, ISBN 978-0-415-68904-5.

This chapter considers the technology curriculum of some selected countries: Australia, China, Germany, Israel, South Africa, Sweden, UK and the USA, and why there are differences. It is intended that the reader reflects on why the schemes of work that they are currently teaching area as they are – and what could be different. What lessons are to be learnt from other countries?

12. Banks, F. (2011) ‘Technological Literacy in a Developing World Context: The Case of Bangladesh’ in de Vries, M. J. (ed.) *Positioning Technology Education in the Curriculum*, Sense Publishers: Rotterdam, Netherlands, pp. 219-226, ISBN: 978-94-6091-674-8.

This chapter uses a framework of the ‘Specified Curriculum’, the ‘Enacted Curriculum’ and the ‘Experienced Curriculum’ to explore the teaching of Technology in Bangladesh. The specified curriculum relates to the formal intended learning outcomes that are either explicitly or implicitly set out for teachers by the government or their employer if an NGO or community school. The enacted curriculum relates to the teaching strategies enacted by the teacher and so is linked to their professional knowledge. The experienced curriculum relates to student learning and achievement and the learning environment.

13. Banks, F. and Chikasanda, V. (2015) ‘Technology Education and Developing Countries’ in Williams P.J., Jones, A. and Bunting, C. (eds.) *The Future of Technology Education*, Springer: Singapore, pp. 217-238, ISBN 978-981-287-169-5.

This chapter considers the broad technology and technical education of two developing countries, Bangladesh and Malawi. These countries were chosen as they are both ex-British

colonies and current members of the Commonwealth; they share similar logistical and economic difficulties in relation to teachers and teaching but are very different in their geography and language of instruction. Looking to the future, the chapter discusses implications for teachers, teacher educators, curriculum materials developers and policy makers.

Chapter 4 Theme 3: Developing Teachers of STEM

14. Banks, F. and McCormick, R. (2006) 'A Case Study of the Inter-Relationship between Science and Technology: England 1984-2004' in de Vries, M. J. and. Custer, R (eds.) *International Handbook of Technology Education*, Sense Publishers: Rotterdam, Netherlands, pp. 285-312, ISBN 90-77874-12-7.

This chapter considers science and technology developments in England over the period 1984-2004 both separately and together, through their common features, by considering three strands: the curriculum rationale (specified curriculum), teacher knowledge (enacted curriculum), and pupil learning (experienced curriculum), as used in **Publication 12**²⁷.

15. Banks, F. (2013) 'Innovation Education through Science, Technology, Engineering, and Math (STEM) Subjects: The UK Experience' in Shavinina, L.V. (ed.) *The International Handbook on Innovation Education*, London: Routledge, pp. 557-569. ISBN 978-0-415-68221-3.

²⁷ Banks, F. (2011) 'Technological Literacy in a Developing World Context: The Case of Bangladesh' in M. de Vries (Ed) *Positioning Technology Education in the Curriculum*, Sense Publishers, Rotterdam, Netherlands, pp.219-226,

This chapter draws on 30 years of projects and initiatives across the UK intended to increase the relevance of the curriculum to life outside the school, to promote creativity and enterprise and to foster innovation through ‘minds-on’ as well as ‘hands-on’ teaching strategies. There is much to celebrate in promoting and facilitating innovative Product Design for students of all ages across the UK, but there have been many obstacles to overcome at national and local levels too. This chapter explores both aspects.

- 16.** Banks, F. and Barlex, D. (2021) *Teaching STEM in the Secondary School: Helping teachers meet the challenge*, (Second edition) London: Routledge, ISBN 978-0-367-33045-3 **F. Banks’ Chapters used:** 1, 6, 9 and 10.

This book looks at the purposes and pedagogy of Science, Technology, Engineering and Mathematics (STEM) teaching and explores the ways in which STEM subjects can interact in the curriculum to enhance student understanding, achievement and motivation. By reaching outside their own classrooms, teachers can ‘look sideways’ to collaborate with colleagues across STEM subjects to enrich learning and help students relate the STEM subjects to the wider world.

Chapter 5 Conclusion: Contribution to new knowledge and a summary of reception and impact in the field

In this chapter the outcome of the research questions and the contributions of the publications to new knowledge in the field are summarised. The status of each journal and the number of citations is set out to indicate the impact that the publications have had on the work of colleagues.

Chapter 2 Theme 1: Teacher Professional Knowledge

Research Question 1 (RQ1): What are the elements of teacher professional knowledge and what is their inter-relationship?

1. Banks, F. R.J. (1988) A Preliminary Evaluation of the Two-Year PGCE and Diploma in Physics, Swansea: University College of Swansea, Education Department Research Monograph No. 1.
2. Banks, F.R.J. (1996) 'Developing professional knowledge during initial design and technology teacher Education', *Journal of Design and Technology Education*, **1** (2) 175-178, ISSN 1360-1431.
3. Banks, F. (1997) 'Assessing Technology Teacher Professional Knowledge' *Proc. of PATT-8 Conference*, Scheveningen, Netherlands, April 1997, pp. 240-251.
4. Banks, F., Leach, J. and Moon, B (2005) 'Extract from "New understandings of teachers' pedagogic knowledge"', *Curriculum Journal*, **16** (3) 331-340, ISSN 0958-5176.
5. Banks, F., Barlex, D., Jarvinen, E-M, O'Sullivan, G., Owen-Jackson, G. and Rutland, M. (2004) 'DEPTH - Developing Professional Thinking for Technology Teachers: An International Study', *International Journal of Technology and Design Education*, **14** (2) 141-157, Holland: Kluwer Academic Publishers, ISSN 0957-7572.
6. Banks, F. (2008) 'Learning in DEPTH: Developing a Graphical Tool for Professional Thinking for Technology Teachers', *International Journal of Technology and Design*, Springer, **18** (3) 221-229, ISSN 0957-7572. (Guest Editor for this Special Edition of DEPTH papers).

To address RQ1, the publications considered in Theme 1 cover exactly 20 years of research into Teacher Professional Knowledge and the development of tools to give teachers - whether they are involved in initial teacher education as either a student teacher or a school mentor or taking part in in-service courses - an opportunity to think about and articulate aspects of their practice. A vocabulary describing professional knowledge makes more explicit a teacher's professional practice that is often tacit and difficult to explain. The work on Teacher Professional Knowledge made a significant contribution to the development of that vocabulary and of thinking about such knowledge internationally.

This chapter is split into three chronological phases: Phase 1: The initial empirical studies; Phase 2: Theoretical development and a revised diagrammatic outcome; and Phase 3: The use of a graphic tool.

2.1 Literature review of Teacher Professional Knowledge

2.1a Phase 1: The initial empirical studies

The stumbling way in which even the ablest of scientists in every generation has to fight through the thickets of erroneous observations, misleading generalisations, inadequate formulation and unconscious prejudice is rarely appreciated by those who obtain their scientific knowledge from textbooks (Conant-Bryant, 1951).

Although referring to the epistemology of science, this quotation summarised my feelings about evaluating the new 2-year Physics PGCE at University College of Wales, Swansea where students improved their subject knowledge by their studies in the Physics Department, and concurrently learned the pedagogy of teaching physics in the Education Department over the two years. **Publications 1** and **2** are empirical studies that use a mixed methods approach to investigate the experience of student teachers following a PGCE course. In both initial teacher education courses, the need for students to expand subject knowledge while learning pedagogy was explored. The categories of school physics explored drew on the work done with non-specialist but experienced teachers of Physics (Millar, 1987), but was adapted for these students who were developing as subject specialists and were *not* experienced teachers. The opinions of the students were gathered by questionnaire and interview, and they were observed teaching in the classroom. The Physics Department staff were interviewed and their views as to the important subject knowledge for teaching physics were explored. Using a

postal questionnaire, Heads of Departments of Physics in local schools gave their views about the difficult topics in Physics and the key teaching strategies that needed to be stressed in a PGCE. Responses from 21 department heads were received from the 26 comprehensive high schools in West Glamorgan. The mixed methods strategy of this limited case study was informed by McCormick and James (1987), Parlett and Hamilton (1972), Stake (1967), Stenhouse (1982) and Wragg (1987).

A similar empirical approach was used to gather the views of OUPGCE students of Design and Technology. The OUPGCE course team took the view that the course should focus on key teaching strategies in the specific subject, considerations of how pupils learn, planning of lessons, assessment of learning and aspects of the wider professional role such as pastoral support. A further key area for Design and Technology student teachers was the importance of auditing and improving their subject knowledge. The so-called ‘foundation subjects’ of Educational Sociology, Philosophy and Psychology were not taught. The OUPGCE relied on school mentors to work with the student teachers to advise them on how to improve their teaching but also to help the students improve their subject expertise, particularly in designing and making, systems thinking and electronics. **Publication 2** is an empirical study that brings together two issues that troubled the OUPGCE course team when designing the course and led to debate in the related Centre of Research into Teacher Education (CReTE), namely: ‘What are the different aspects of teacher professional knowledge that need to be made explicit so that mentors and student teachers have a shared vocabulary to discuss action in the classroom?’ and ‘How can such professional knowledge be best illustrated?’ **Publication 2** drew on the body of research in the 1980s that focussed on knowledge for teaching in the classroom such as Shulman and Sykes (1986), Shulman (1986), and Grossman, Wilson and Shulman (1989).

McNamara (1991, p. 115) summarised the field which I adapted and presented as follows:

Subject content knowledge – Design and technology is a very broad subject but a good understanding of a substantive part of the subject is important. Teachers' subject matter knowledge influences the way they teach, and teachers who know more about a subject will be more interesting and adventurous in their methods and, consequently, more effective.

Pedagogical content knowledge – (Shulman, 1986, p. 9) “Within the category of pedagogical content knowledge I include, for the most regularly taught topics in one's subject area, the most useful forms of representation of those ideas, the most powerful analogies, illustrations, examples, explanations and demonstrations – in a word, the ways of representing and formulating the subject matter that make it comprehensible to others.”

Curricular knowledge – This area of teacher knowledge for Design and Technology covered understanding of different published schemes, and the relationships between ‘Capability Tasks’ (whole project), ‘Resource Tasks’ (focused activities to teach a specific skill or specific understanding needed for the whole project) and investigating of existing products that might influence the whole project.

School-Subject knowledge – By altering the subject to make it accessible, a version of school design and technology is created which is different to how technology is conducted outside school. The emphasis on the design ‘process’ and ‘portfolio’ and

their importance in the assessment process is very much what student teachers must quickly understand.

Interviews with 17 OUPGCE Design and Technology student teachers gave some confidence that the resulting areas of teacher professional knowledge shown in Figure 1 are meaningful.

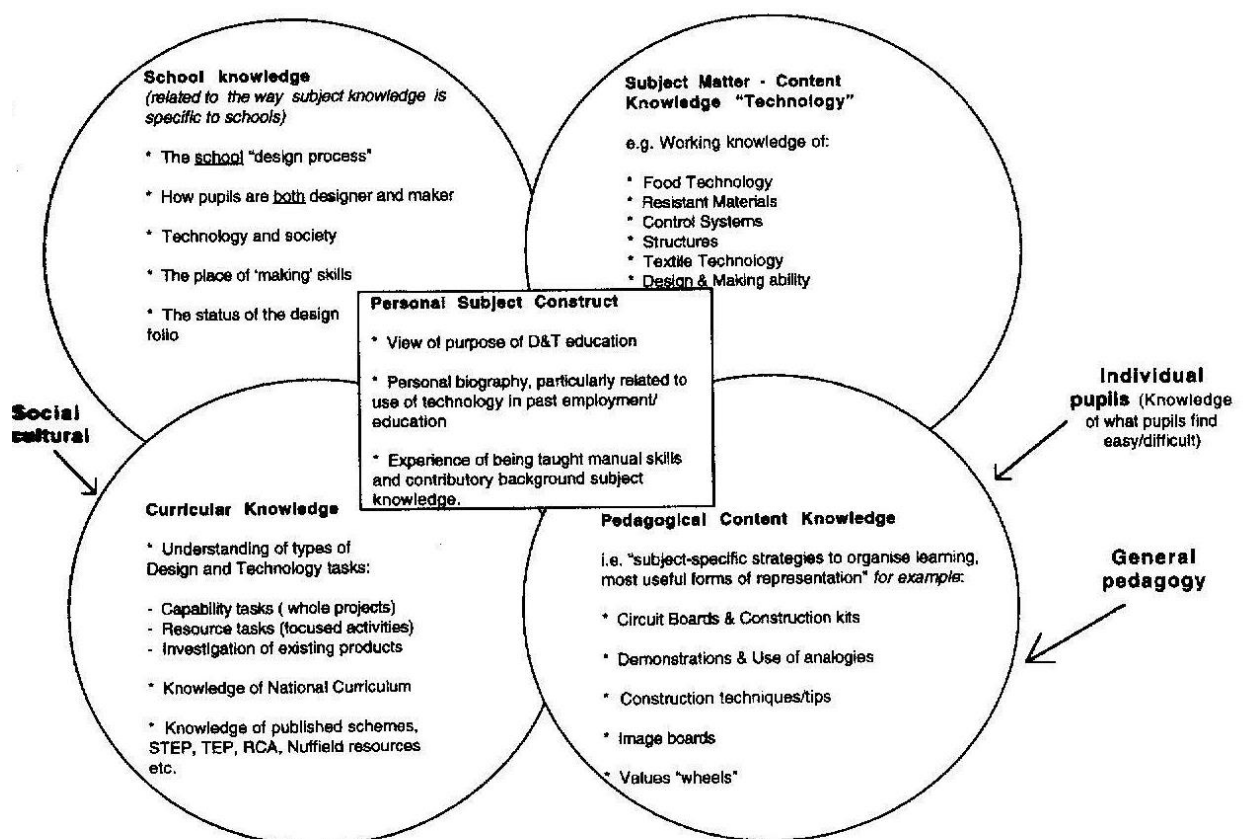

Figure 1: Display of results from the empirical study of 17 OUPGCE Design and Technology Student teachers.

A deeper consideration of the necessary subject knowledge for teaching is considered in **Publication 3**. When they begin their courses, students have quite different 'personal subject constructs' about what they believe D&T education is for and how it should be taught. As shown in **Publication 2**, they also come into the profession with very different subject knowledge strengths. Their past experience as a learner of technology, a personal view of

what constitutes 'good' teaching, and their individual belief in the purpose of D&T, underpins a teacher's professional knowledge. Their teaching ideology is in part formed by these standpoints, and this is as true for any teacher. A student teacher has to question his or her personal beliefs about their subject as they work out a rationale for their classroom behaviours. But so must those teachers who, although more experienced, have undergone profound changes of curriculum emphasis during their career. These mentors, therefore, have particular expectations of 'competence' which are influenced by their own curriculum histories. However, as it was a new national curriculum subject, all teachers found the move to teaching Design and Technology difficult. Harrison noted the following:

D&T teachers have been that only since 1990, having previously been CDT (and, before that, woodwork, metalwork or technical drawing) teachers or HE (and, before that, domestic science or needlework or cookery) teachers or BS (and, before that, shorthand and typing) teachers, and so on. All of them had a confidence associated with particular ways of doing things needing particular familiarity with specialized equipment. And all were surviving with their own support structure (Harrison, 1993, pp. 273-275).

The slip in confidence of these teachers who were being asked to change their 'personal subject construct' in order to move from their current subject environment to the new one of 'Technology' was revealed by a survey conducted by the Design and Technology subject associated (DATA, 1994):

Element of national curriculum design and technology (D&T)	% of teachers with no training at all in the element	Element of national curriculum technology	% of teachers who consider themselves to be inadequately trained to teach a particular element of D&T
	%		%
Business	78	Design	75
Hydraulics	41	CAD	54
Computer Control	34	CAM	53
Pneumatics	34	Electronics	52
CAD	31	Computer Control	51
CAM	27	Pneumatics	48
Graphics	26	Hydraulics	46
Plastic	25	Business/Economics	42
Electronics	24	Graphics	27
Electricity	19	Structures	27
Food	19	Mechanisms	24
Ceramics	17	Electricity	20
Mechanisms	14	Textiles	19
Textiles	14	Food	17
Design	13	Ceramics	17
Wood	13	Plastic	14
Structures	12	Wood	12
Metal	8	Metal	7

(DATA 1994)

Table 2: Survey results of Technology teacher subject knowledge (DATA, 1994).

During initial teacher education, school craft teachers tend to follow the ‘*école normale*’ tradition of a concurrent model. This model emphasises ‘practical’ training and rather devalues both educational theory and academic preparation. There is a strong emphasis on being the ‘right personality’ for teaching, and student teachers are inducted into schools by association with a mentor as a ‘master teacher’ (Banks, 2006b).

The preparation for teachers at upper secondary schools has generally been in the ‘academic’ tradition. A thorough academic preparation followed (more or less consecutively) by exposure to the education foundation subjects of Philosophy, Psychology and Sociology of Education was assumed to prepare student teachers to work in the ‘studious’ atmosphere of the schools. Again, education theory, methodology and school experience are rather

neglected. Traditionally, science teachers have tended to be educated by this more academic model and it has led to those teachers adopting a 'high technology' approach to their technology curriculum. It was to enhance the school experience element of this model that the 1992 changes were implemented. The crudest separation of these traditions may be said to be between those who see themselves as 'a teacher of children' and those who are primarily 'a teacher of subject'.

In the middle 1990s, the use of competences to assess student teachers had been accepted as a necessity by a number of teacher-education departments, including The Open University, as a pragmatic solution to the problem of classroom assessment of student teachers by school mentors. An 'expert panel' at DATA, the subject association for design and technology teachers, worked swiftly to set out what the 'minimum competences' for student teachers should be (Banks *et al.*, 1995).

The differences between 'school technology' and 'technology content knowledge' as practised outside school poses particular problems when determining competence in subject content knowledge. Attempting to set out the minimum competences for students to teach Design and Technology in the secondary schools of England and Wales was a formidable task even though it only attempted to put into a subject-specific context the general competences which had been defined by government for all teachers. One major difficulty was the breadth of the 'school knowledge' in Design and Technology. The national curriculum for Design and Technology (D&T) included learning about four 'fields of knowledge': resistant materials, food technology, textiles technology, and control and systems (Figure 2).

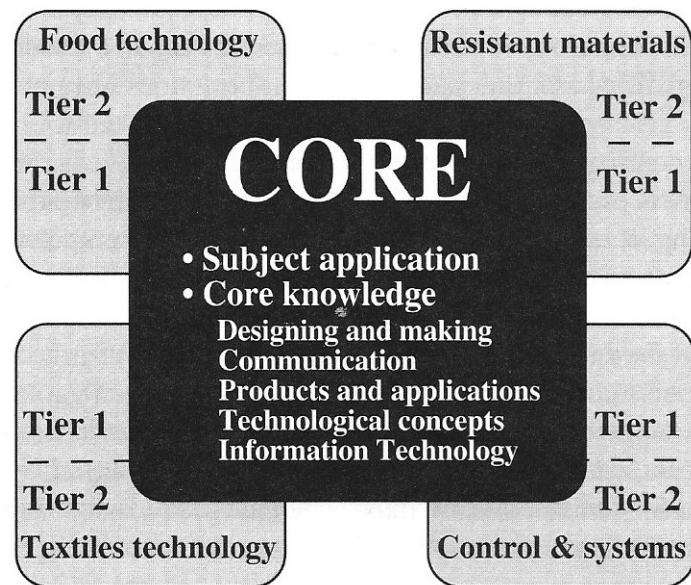

Figure 2: (Banks *et al*, 1995, p. 8) Core competences for Design and Technology and fields of knowledge.

But no teacher will have been educated to degree level in *all* of these fields. So, what is an appropriate level of subject knowledge to be considered ‘competent’? A pragmatic solution was to determine that there should be a core of subject knowledge which all D&T teachers should know, and that teachers’ knowledge after that should be more specialised. The four fields of knowledge were divided into two ‘tiers’ or levels of difficulty. Tier 1 is the knowledge and understanding that enables the newly qualified teacher to teach technology confidently to 14-year-old pupils. Tier 2 is the knowledge and understanding required to teach up to university-entrance level. A teacher should be at Tier 2 level in at least one field of knowledge and Tier 1 level in at least one other (Figure 3). In this way depth of understanding is combined with breadth. Although these recommendations were not initiated by government, many teacher education institutions have taken them as a basis for designing the subject knowledge element of their courses.

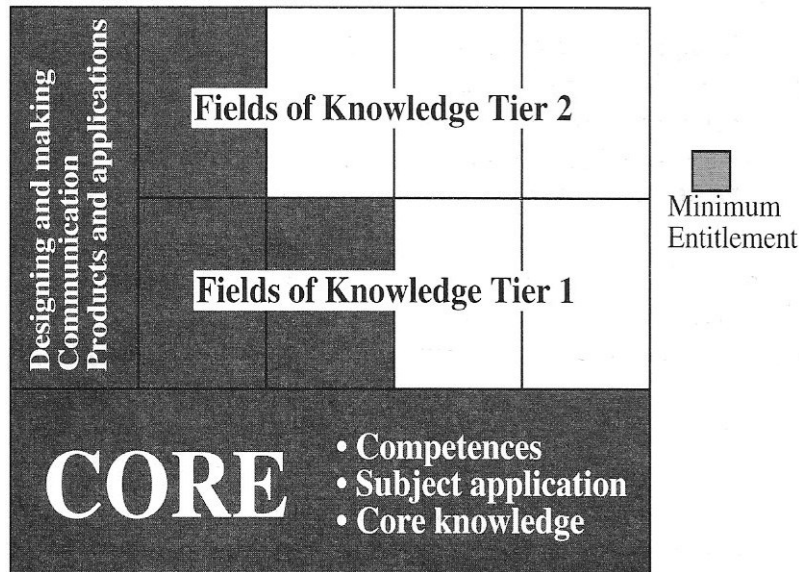

Figure 3: (Banks *et al.*, 1995, p. 9) Diagrammatic representation of a student's 'minimum competences'.

In 2013, changes to the National Curriculum in England and the new examination qualifications were introduced bringing electronics, control technology, resistant materials and textiles into one combined subject. Instead of teachers being expected to have specialist knowledge in just one or two material areas as shown in Figure 3, now teachers are required to know about a wider variety of materials (See Hardy, 2021).

When the categories of teacher knowledge in Figure 1 are presented to a teacher or teacher-trainer audience there are usually two reactions. The first, and more prevalent, is to acknowledge the usefulness of the classification as a means to raise the debate about teacher knowledge and to provide a framework for discussion. The second is something along the lines of "but surely teaching is more than this!", that there is an ineffable quality about teaching that can't be captured in so crude a way. But that, perhaps, is to miss the point of such diagrams which are developed as a crutch to help inter-teacher dialogue.

It was through such discussion that the empirical studies shown in **Publications 1, 2 and 3** were taken forward to a more refined understanding of teacher professional knowledge. This revised conceptualisation is considered next in Phase 2.1b.

2.1b Phase 2: Theoretical development and empirical verification of a revised summary diagram

As was illustrated in **Publication 2**, since the mid-1980s there has been a growing body of research into the complex relationship between subject knowledge and pedagogy as discussed by Shulman and Sykes (1986), Shulman (1987), Wilson, Shulman and Richert (1987), and MacNamara (1991). Shulman's original work in this field was an obvious starting point, arising from the pertinent question:

How does the successful college student transform his or her expertise into the subject matter form that high school students can comprehend? (Shulman, 1986, p. 5)

Shulman's conceptual framework setting out the distinction between *subject content knowledge*, *curricular knowledge* and *pedagogic content knowledge* spawned a plethora of subject specific research from, for example, Leinhardt and Smith (1985), Grossman *et al.* (1989), Wilson and Wineberg (1988), and McDiarmid, Ball and Anderson (1989).

Reflection and discussions in preparation for **Publication 4**, however, although acknowledging Shulman's analysis as an important and fruitful starting point, led to the view that it offered only partial insight into the complex nature of subject expertise for teaching.

We were critical in particular of Shulman's implicit emphasis on professional knowledge as a

static body of content somehow lodged in the mind of the teacher. Shulman's work, we argued, is informed by an essentially objectivist epistemology. In this tradition academic scholars search for ultimate truths, whilst teachers 'merely seek to make that privileged representation accessible to ordinary mortals' (McEwan & Bull, 1991, p. 320). Pedagogical content knowledge as defined by Shulman requires the subject specialist to know:

the most useful forms of analogies, illustrations, examples, explanations, and demonstrations – in a word, the ways of representing and formulating the subject in order to make it comprehensible to others (Shulman, 1986, p. 6).

From this perspective, Shulman's work leans on a theory of cognition that views knowledge as a contained, fixed and external body of information but also on a teacher-centred pedagogy which focuses primarily on the skills and knowledge that the teacher possesses, rather than on the process of learning. This is illustrated in the following (my italics):

The key to distinguishing the knowledge base of teaching lies at the intersection of content and pedagogy, in the capacity of *a teacher to transform the content knowledge he/she possesses* into forms that are pedagogically powerful and yet adaptive to the variations in ability and background presented by the students (Shulman, 1987, p. 15).

Publication 4 explains the dissatisfaction with the conceptualisation of teacher knowledge encapsulated in Figure 1, **Publication 2**. The revised thinking drew on the perspective of the learner and that of the teacher.

The learner perspective

Gardner's (1983) work by contrast to Shulman's provides a perspective on professional knowledge which is rooted in a fundamental reconceptualisation of knowledge and intelligence. His theory of multiple intelligences, centrally informed by the socio-cultural psychology of Bruner (1986; 1996), encourages a perspective on pedagogy that places emphasis on student understanding. The focus shifts from teachers' knowledge to learners' understandings, from classroom techniques to purposes. The five entry points which Gardner (1991) proposes for approaching any key concept - narrational, logical-quantitative, foundation, experiential and aesthetic - do not simply represent a rich and varied way of mediating a subject. Rather they emphasise the process of pedagogy and a practice which seeks to promote the highest level of understanding possible (Gardner & Boix-Marsella, 1994). At the same time, Gardner's work places discipline and domain at the core of pedagogy. Drawing extensively from Dewey, he argues that understanding through disciplinary knowledge is indispensable:

Organised subject matter represents the ripe fruitage of experiences...it does not represent perfection or infallible vision; but it is the best [route] to further new experiences which may, in some respects at least, surpass the achievements embodied in existing knowledge and works of art (Gardner & Boix-Marsella, 1994 p. 198).

Gardner's espousal of disciplinary knowledge has in earlier exchanges been criticised. Gardner, says Egan (1992), seems to offer progressive programmes to achieve traditionalist aims (p. 403) and Egan goes on to argue that Gardner's solution:

appears to assume that effective human thinking is properly more disciplined, more coherent and more consistent than seems to me to be the case. This is not an

argument on behalf of greater indiscipline, incoherence and inconsistency, but a speculation that human thinking operates very effectively with a considerable degree of those characteristics, and that attempting to reduce them to greater conformity with what seems like rules of disciplinary understanding – whose provisionalness and unclarity should not be underestimated – will more likely reduce our humanity or enhance it (p. 405).

He adds:

[...] the danger of letting disciplinary understanding call the educational tune was, for Dewey, no less than an attack on democracy itself. It inevitably led to an aristocracy, or meritocracy, and so to the kinds of social divisions America was founded to prevent (p. 405).

Gardner's work has been critical in challenging views of cognition based on the concept of 'intelligence', and his work is central to an endeavour to challenge widely held notions of ability as fixed and unchanging (see Gardner, 1993). His espousal of disciplines and exploration of curricula which are rooted in but which move beyond disciplines into 'generative themes' has given rise to some important work such as Project Zero (Gardner, 1993; Sizer, 1992). However, it has little epistemological analytical underpinning.

The teacher perspective

For this we turned to the work of Verret (1975) and of Chevillard (1991). The concept of didactic transposition, a process by which subject knowledge is transformed into school knowledge, an analytical category in its own right, permits us both to understand and to question the process by which disciplinary transformations take place. The range of historical examples in Verret's work also provide for the social and ideological dimensions of

the construction of knowledge. *La transposition didactique* of Chevallard is defined as a process of change, alteration and restructuring which the subject matter must undergo if it is to become teachable and accessible to novices or children. Verret's original thesis was that school knowledge, in the way it grows out of any general body of knowledge, is inevitably codified, partial, formalised and ritualised. Learning in that context is assumed to be programmable, defined in the form of a text, syllabus or national curriculum, with a conception of learning that implies a beginning and an end, an initial state and a final state. Verret argues that knowledge in general cannot be sequenced in the same way as school knowledge and that generally learning is far from being linear. Such a model, he suggests (in ways that predate Gardner), lacks cognitive validity as it does not take into account the schemes, constructed representations and personal constructs of the learner.

Verret's thesis is illustrated by a range of historical examples. He describes, for instance, the transformation of literature and divinatory magic into the scholastic forms of Confucian schooling, and of Christian metaphysics into school and university philosophy. He looks in detail at the version of Latin that was constructed for the French schools of the seventeenth century and the way that this evolved didactically in the centuries that followed.

For Chevallard, as with Verret, 'didactic objects', which we have termed 'school knowledge' are under constant interpretation and reinterpretation, a process which operates at a number of different levels. Didactic transformation of knowledge, therefore, becomes for Tochan and Munby (1993):

a progressive selection of relevant knowledge, a sequential transmission involving a past and a future, and a routine memory of evolutionary models of knowledge.

Because didactics is a diachronic anticipation of contents to be taught it is

essentially propositional. It names teaching experience in propositional networks and so involves a mediation of time (pp. 206–7).

The process of didactics is carefully distinguished from pedagogy:

Some research on [the pedagogy of] novice teachers suggests that they have abilities to plan but encounter problems during immediate interactions. They seem to identify their role as a mainly didactic one. Their way of organising time has no flexibility; it is not synchronic ... Though action research and reflection reveal the existence of basic principles underlying practical classroom experience, no matter what rules might be inferred pedagogy still remains an adventure (pp. 206–7).

The revised understanding of teachers' pedagogic knowledge

Figure 4 represents in diagrammatic form a synthesis of the interrelation of subject knowledge, school knowledge, and pedagogical knowledge and is the result of the studies that address Research Question 1 - What are the elements of teacher professional knowledge and what is their inter-relationship?

It is a simpler, revised version of Figure 1 and a new starting point for conceptualising teacher professional knowledge.

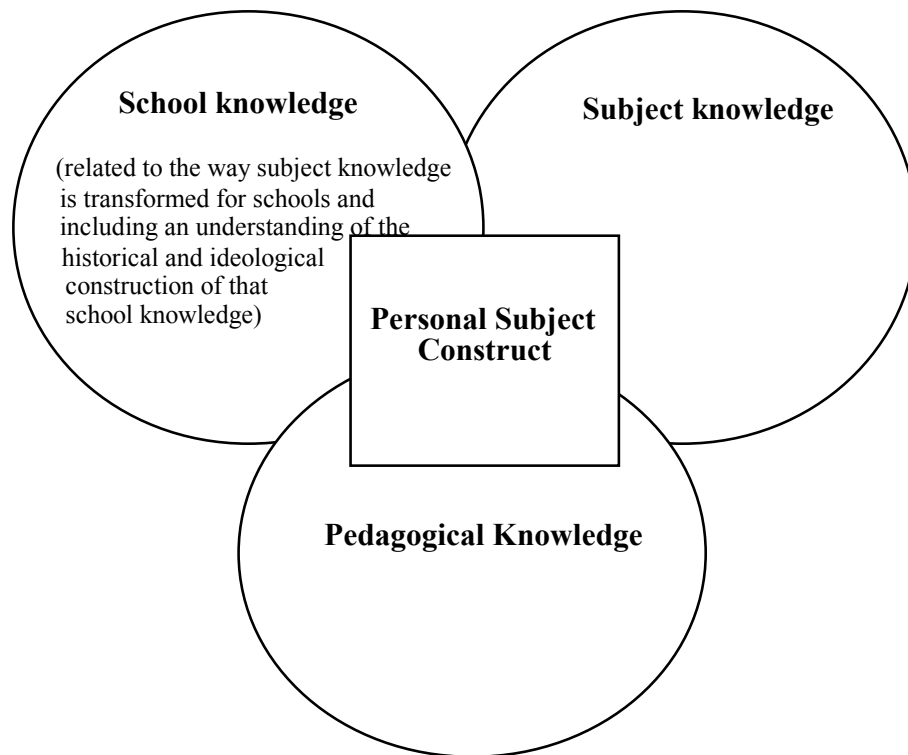

Figure 4: Teachers' professional knowledge

Shulman's category of subject content knowledge is retained but denoted simply as **subject knowledge**. In making this change we wished to emphasise the dynamic, process-driven nature of 'subject knowledge' which encompasses 'essential questions, issues and phenomenon drawn from the natural and human world, methods of inquiry, networks of concepts, theoretical frameworks, techniques for acquiring and verifying findings...symbol systems, vocabularies and mental models' (Gardner, 1994). **School knowledge**, we suggested, is an analytic category in its own right, subsuming the *curricular knowledge* of Shulman. We have, therefore, split the category of *pedagogic content knowledge* as defined by Shulman, to gain a greater hold on this important epistemological construct. By 'school knowledge', we do not mean a knowledge of the school context. Rather we view it as the transposition of subject knowledge referred to above.

Our third category, which we called **pedagogical knowledge**, we see as going *beyond* the generic set of beliefs and practices that inform teaching and learning. Although these exist, and rightly form an important part of the development of teacher expertise, they are insufficient (we would argue), unless integrated into an understanding of the crucial relationship between subject knowledge and school knowledge.

One might initially see 'school knowledge' as being intermediary between 'subject knowledge' (knowledge of technology as practised by different types of technologists for example) and 'pedagogical knowledge' as used by teachers (the most powerful analogies, illustrations, example, explanations and demonstrations). This would be to underplay the dynamic relationship between the categories of knowledge implied by the diagram. For example, a teacher's subject knowledge is transformed by their own pedagogy in practice and by the resources which form part of their school knowledge.

It is the active interaction of subject knowledge, school knowledge and pedagogical understanding and experience that brings teacher professional knowledge into being.

Lying at the heart of this dynamic process is the **personal subject construct** of the teacher, a complex amalgam of past knowledge, experiences of learning, a personal view of what constitutes 'good' teaching and belief in the purposes of the subject. This all underpins a teacher's professional knowledge and holds good for any teacher. A student teacher needs to question his or her personal beliefs about their subject as they work out a rationale for their classroom practice. But so must those teachers who, although more expert, have experienced profound changes to what constitutes 'school knowledge' during their career.

The empirical underpinning – showing the model in use.

The above exposition might imply that the new understanding of teacher professional knowledge was a theoretical model constructed in a vacuum. This is not so. The empirical work that underpinned the development of the revised model of teacher professional knowledge is set out here for clarity. The case study that follows is a classroom observation of two technology student teachers, part of the group of 17 participants who agreed to be interviewed as discussed in **Publication 2**. It is also set out as a key element in the case study of the inter-relationship between science and technology subject knowledge that is discussed in **Publication 14**²⁸.

‘Alun’ and ‘Geoff’

Although they are at the *beginning teaching* phase of their course, the student teachers here called ‘Alun’ and ‘Geoff,’ have already planned and begun to pair-teach a series of lessons for their placement school. The department was concerned that the existing school scheme of work which was offered in Year 7 did not yet include aspects of simple electronics. Their mentor asked Alun and Geoff, working as a pair, to organise the teaching of this.

Significantly, the mentor herself lacked subject knowledge in this area (having a business studies background) and asked the students to come up with the resources for a project which the whole department could use. She thought that a knowledge of subject should enable the students to produce an adequate resource. Using classroom observation, the following was noted.

²⁸ Banks, F. and McCormick, R. (2006) ‘A Case Study of the Relationship between Science and Technology: England 1984-2004’ in de Vries, M. J. and Custer, R (eds.) *International Handbook of Technology Education*, Sense Publishers: Rotterdam, Netherlands, pp. 285-312.

Although some advice was given by the Science Department, the students were largely left to themselves. Using their own ideas and curriculum materials such as textbooks and electronic kits already in the school, the students decided to organise their teaching around the development of a face mask with flashing eyes. They found this a very difficult exercise. A particular lesson required the pupils to investigate which materials were conductors and which insulators. For this the student teachers employed a standard kit called *locktronics* but talked about the required circuit by drawing diagrams on the chalkboard.

Subject knowledge

The students' own understanding of simple electricity was sufficient but lacked the 'flexible and sophisticated' features to ensure that it was conveyed clearly (McDiarmid *et al.*, 1989). They understood electricity themselves but were unsure of the depth and nature of the topic which was pertinent to this design-and-make task. For example, a description of current flow (the convention of current flow is from positive to negative) also involved a discussion of flow of *electrons* (which are negative so flow from negative to positive). Both ideas are correct, and Alun and Geoff taught the ideas correctly, but by combining them together on the same diagram many pupils found the clashing arrows confusing. An electrical symbol of a battery was added (incorrectly) to the diagram. The rather unsatisfactory chalk-board illustration shown in Figure 5 was the overall result.

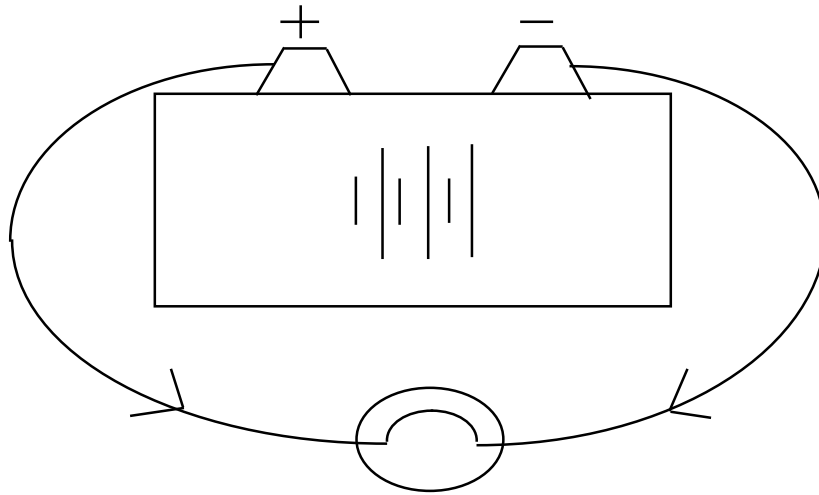

Figure 5: An apparent “clashing currents” board diagram

School knowledge

The purpose of the project was unclear in the minds of the student teachers. When describing the task, they would sometimes see it as a means to teach designing and making (a practical 'capability task'): however, the functional aspects of wearing the mask were not thought through. For example, the student teachers had not considered the weight or where the battery would be located on the mask, or how it would be supported. They also recognised practical skills such as soldering as being central to the task but had not allowed enough time to develop such skills. In practice, the face mask became a subsidiary context to teach aspects of electronics.

They thought that an understanding of $V=IR$ (Voltage = Current x Resistance) was important, but the Science Department had suggested that the manipulation of such an equation was too difficult for many 11-year-old pupils. Their desire to teach the *science* subject background, such as (in this lesson) conductors and insulators and the existence of electrons, cut down on the time for making. They were unclear if the overall purpose of the activity was designing, acquiring specific skills, or a 'seeing-is-believing' confirmation of scientific principles. Their prior selection of the subject knowledge they wished to teach was transposed into knowledge

for teaching, but their understanding of school technology knowledge was poor without the necessary pedagogic rationale or appropriate strategies.

Pedagogical knowledge

Only Geoff had used the electronics kits before as a pupil, and both student teachers were unfamiliar with the way they could be used in the classroom. The pupils had some difficulty in manipulating the components and interpreting the circuits which they had constructed on the boards. For example, the pupils did not easily link up the connectors to make the bulb light as they invariably first constructed a loop of wire to the bulb before connecting the power supply (referred to as a battery in the original explanation by the student teacher). Later the pupils did not see how the kit could be adapted to accommodate different shaped rods of various materials in an experiment to clarify 'conductors' and 'insulators'.

As these students were not able to enlist the experience of their mentor, they drew on their own embryonic pedagogical knowledge to formulate teaching activities for the project. They naturally used analogies to try to convey ideas about electrical flow. For example, Geoff talked about how it is easier to walk around a hill, rather than walk over it, in an attempt to quickly cover the idea of a short circuit. As they considered a knowledge of electrons an essential pre-requisite to an understanding of conductors and insulators, Alun showed the following real model and then talked about it using this chalk-board diagram:

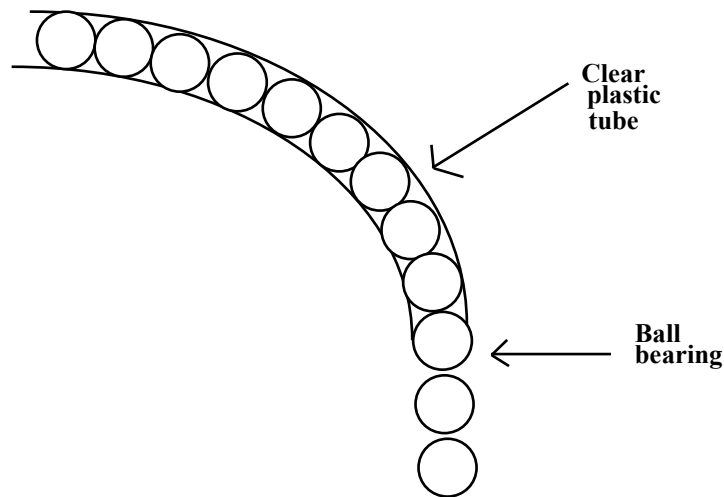

Figure 6: Simulation of 'electrons' in a wire

The actual tube, shown to the pupils later, represented the wire and the ball bearings were the electrons. It is unclear, however, what the pupils thought about the size of electrons and the need for a conductor for electron flow.

After the lesson, Alun and Geoff took part in a previously agreed in-depth interview of which the following is an extract. First, Alun was asked where the tube and ball bearing analogy of electron flow came from:

Alun: Well, I picked it up from a book but er...yeah, I don't think I've ever seen anything like that, I just thought if I used the analogy, it would be helpful rather than just explaining it.

I: There were a number of analogies that were used in the lesson in general. Where did the idea of using analogies for electricity come from, I mean, why do it like that? For example, Geoff was talking about 'would you go round the hill or would you go over the top of the hill'...

Alun: I don't know where he got that from.

I: Have you ever heard anything like that before?

Alun: Yes. Yeah, yeah...er, electricity flowed through the easiest part that water would have found and things like that, I've come across them yes. I can...I've got a bit of an idea, never thought of using it but he brought it into the context quite well. Um...I don't know, do you learn these things through life? Possibly so. Reading...

and Geoff, separately, reinforced this didactic role missing the fact that the pedagogy employed in the lesson was having limited success (See Tochan & Munby, 1993):

I: How did you come up with what to do and when?

Geoff: Well, we sort of sat down. I had a project that I'd seen a friend of mine had done a few years back - he's a teacher, now - so we had that to start. It was a different project, but it was electronics. It was a different circuit but basically...slightly different, but we had the way he's structured it, we had a look at that and said, 'Right, what's good about this, what's missing?' and what have you. We also went through a lot of books, different books, and if you read them, they're all basic electricity or electronic books, they're all a bit much the same. They all go through the same steps as well. You've got to start at the beginning, so if you haven't done anything on what electrons are or what a conductor is, then how do you explain to them why it's flowing later on? We've got...if you just stick the circuit up there, you're going backwards, and we decided...what is the *basics* of it? What are the mechanics of any circuit? - and come through it that way.

The student teachers wished to scaffold the learning of the pupils and they believed a hands-on approach was appropriate. However, they found it difficult to leave the pupils to

experiment with the kits, and continually intervened to move them on as time was felt to be so short. In retrospect, Alun and Geoff felt that too much was attempted too quickly, and some pupils became confused then bored. The students did not have the pedagogical knowledge to know which aspects of electricity are difficult to convey. Indeed, they were unsure of how all this fitted into school knowledge of technology as they were unclear about *why* they were teaching this in relation to this particular design-and-make project.

Personal subject constructs

Both Geoff and Alun have a personal subject construct moulded by experience in industry which strongly influences their direction and orientation to how and why pupils should learn Technology. They both see hands-on experience as being vital (although they got side-tracked by a belief that detailed theoretical science concepts are an inevitable precursor to understanding of school technology) and wish to emphasise a link to marketing the face-mask product (although that aspect was not made explicit to the pupils).

Alun: I've a belief that everyone should follow Technology with a business and a legal aspect, i.e. unless you know how much it's gonna cost, it's pointless designing something [...] Can we make it? Far too often we find we design things which do not take into the remit [...] realistic targets. So I'd like to relate Technology to more...creative depth within the curriculum. We could include Mathematics, i.e. costs, working out costs of things, what it's going to cost you. Er...Perhaps I've deviated slightly there, I don't know. My own views I think you've got there.

Interplay between aspects of teacher professional knowledge

This developed model of teacher professional knowledge (Figure 4) has been discussed with a number of groups of professionals in the UK and in other parts of the world including Spain, the Netherlands, Sweden and South Africa as explained by Banks, Leach and Moon (1996), Leach and Banks (1996), Moon and Banks (1996), and Banks (1997). Among these professionals have been schoolteachers of design and technology but also teachers of English and of mathematics, teacher educators, and education researchers. The reaction to the model across this spectrum of professional expertise has been remarkably similar as follows:

- The different aspects of teacher knowledge are recognised by all these groups as being meaningful. Teachers, in particular, are excited by the categories and

value the model as a way of easily articulating what they know and are able to do. The model has a spin-off for mentoring and initial teacher education, facilitating explicit discussion about the nature of professional knowledge.

- School knowledge is often misunderstood as knowledge of the context for teaching. This illustrates the importance of this category in framing the teachers' role.
- The model can be interpreted at different levels. Some see it as a tool for categorising personal understanding. Others see it as being useful for planning in-service development for a group of teachers.

However, although so many consider a focus on teacher professional knowledge an intriguing and a useful way of making the often tacit classroom behaviours more explicit, some have felt that the focus on 'knowledge' misses a key element of what is needed in teaching. Martin (2017), for example, claims that teaching is just too complex to be reduced to a simple diagram and 'Student 3' in p. 153 in **Publication 5** notes:

How can you look at teaching and ignore the attitude of the teacher, and their enthusiasm towards their subject, their ability to demonstrate and pass on this enthusiasm, and their interest and concern for students, among other things? If all that matters in teaching is knowledge, then I think I'm in the wrong profession. But on the plus side, all three of those things [aspects of teacher knowledge] are important to teaching. Or I should say, to students' learning (which is really what it is all about).

Student teacher 3 is clearly passionate about teaching and feels that the diagram when used as a 'Graphical Tool' in **Publications 5** and **6** can be seen as missing that necessary enthusiasm.

Martin (2017) too considers the model overly ‘scientific’. Also, as is illustrated in 2.2b below, some researchers have elaborated the model to include a range of other attributes they consider necessary for teaching.

As discussed in **Publication 6**, however, there is merit in keeping the model simple in that it can be used and be understood in a range of contexts internationally. But what is key is to fully explain, and for the teacher to fully understand when using the model as a ‘graphical tool’, the essential notion of a ‘Personal Subject Construct’. In Leach and Moon (2008) this is linked to the ‘identity’ of the teacher. The personal subject construct or a teacher’s identity, it is suggested, encapsulates enthusiasm and motivation and what is considered ‘good teaching’ and is the impetus that drives pedagogy. As is shown by the case of Alun and Geoff above, it also gives the *rationale* to what school knowledge and subject knowledge are selected in the classroom. The subject knowledge, school knowledge and the dynamic nature of pedagogic knowledge as used in a classroom are governed by the teacher’s view of what they are ‘being’ as a teacher. It is in that notion of ‘identity’ and what they personally believe about teaching that motivation and enthusiasm resides.

The international use of the graphical model with student teachers is discussed in **Publication 5**, and with experienced teachers engaged in in-service work, illustrated by the research discussed in **Publication 6**.

Publication 4 argues that the development of professional knowledge is a *dynamic* process. It depends on the interaction of the elements identified but is brought into existence by the learning context itself – learners, setting, activity and communication as well as context in its broadest sense.

2.1c Phase 3: The use of a Graphical Tool

In 1999 the PATT proceedings carried a paper that used two small case studies describing the use of a framework for conceptualizing teacher professional knowledge (Banks & Barlex 1999). The authors argued from the case study data that the approach had considerable potential for enabling those about to enter the teaching profession to reflect on their professional knowledge. Others in the teacher education community then engaged with the conceptual framework and carried out similar case studies leading to a collaborative publication involving case studies from England, Finland and New Zealand (Banks *et al.*, 2004) [**Publication 5**]. This work became known as the DEPTH (Developing Professional Thinking for Technology Teachers) project. Four years later the International Journal of Technology and Design Education devoted an entire issue to studies involving the DEPTH project in five different countries (Banks 2008) [**Publication 6**] (Barlex, 2012, p. 57).

This summary by Barlex sets out clearly two aspects of the development of the categorisation of teacher professional knowledge. First, it underlines the way that the description of such teacher knowledge transcends international borders – being as useful in Finland as it is in New Zealand. Second, it showed how the initial diagrams summarising the results of empirical studies, then refined and changed through engagement with the literature, and again checked in the field as described in 2.1b, developed into a study where a blank version of Figure 4 was used firstly with student teachers (**Publication 5**) and later with in-service teachers (**Publication 6**).

In Section 2.2 we consider in detail how the graphical presentation of teacher professional knowledge was received in the field and critiqued, revised and developed by others.

2.2 The contributions of the published works to the research on Teacher Professional Knowledge

There is an ‘arrow of development’ in this section which demonstrates how the first six published works move from a small but unique comparison of the perceived subject knowledge needs of student teachers and those of experienced teachers in **Publication 1** to an international comparison of professional knowledge of teachers in five countries across three continents in **Publications 5** and **6**. The publications have been taken up by researchers around the world as discussed below.

2.2a The contribution of the initial empirical studies

The Postgraduate Certificate in Education (PGCE) course has always been vocational in nature. It is the ‘consecutive route’ to becoming a teacher – three years of learning a subject at degree level plus one year of learning how to teach leading to the PGCE. This contrasts with the ‘concurrent’ model where subject knowledge and learning about pedagogy are integrated over three or four years – the BEd route. In the mid-1980s teacher shortages in subjects such as Mathematics and Physics led to a new third way and in 1988 the innovative ‘two-year’ courses had to address the question of whether subject knowledge needed to be considered ‘vocational’ too. If student teachers holding degrees in subjects other than physics were to become physics teachers, what level and range of subject knowledge, and what teaching strategies would be appropriate for such a course?

It was not clear in the planning stage of such 2-year courses what the entry level of physics should be and preliminary discussions considered 'O' level Physics to be adequate. This level of entry qualification would be appropriate to a large range of likely candidates. Biology graduates who wished to teach might favour physics teaching as a field with reduced competition for employment or even embrace the opportunity to broaden their science knowledge as required for the National Curriculum. However, consultation with the then Department of Education and Science indicated that the Council for the Accreditation of Teacher Education (CATE) criteria which apply to PGCE courses would also apply rigidly to this proposed conversion course. An important principle established by CATE was that it is necessary for all teachers to receive two years post 'A' level education in their teaching subject. As the conversion course could only offer one year full-time equivalent study post 'A' level, students must already have undertaken one year's education in Physics before entry to the course.

This administrative obstacle had a profound effect on the content and development of the 2-year PGCE conversion courses for teachers of shortage subjects, reducing the student market as it prohibited the possibility of converting graduates from the Life Sciences and raised the level of physics subject knowledge that must be taught to students on the course. The students needed enough degree-level physics subject knowledge to meet the CATE criteria, but not enough that they would be accepted onto the conventional one-year PGCE course. Only six students were recruited to hit this 'Goldilocks' position of the level of subject knowledge needed to begin the course.

The preliminary evaluation of this two-year PGCE in Physics course at University College, Swansea (**Publication 1**) researched the extent and nature of the subject knowledge taught in

the Physics Department, the elements of the 'core course' taught in the Education Department which covered aspects of philosophy, psychology and sociology of education along with the wider professional role of a teacher such as teaching students with special needs and the pastoral role of teachers; and the methods course covering teaching strategies for various school topics in Physics. Interviews and questionnaires were completed by college staff in Physics, and by the student teachers on the two-year Physics PGCE before and after teaching placement. The students were also observed on teaching placement twice. Finally, a questionnaire was completed by schoolteachers of Physics as to which subject topics they considered conceptually difficult.

The subject knowledge required for teachers entering the profession became, therefore, a contentious issue on this 2-year PGCE and would be debated later by the OUPGCE team who wished to operate a 'first come, first served' recruitment regime. The students on the 2-year PGCE had all studied Physics to 'A' level standard and so had a notion of what level of physics they might need for teaching but there was no agreement as to what that level of subject knowledge might be. Half of the students suggested that the level of physics was either too difficult or inappropriate for school teaching. Student C said:

The way we are being taught is too mathematical. The maths is causing the problems rather than the physics. The way we are being asked to analyse things we would not be asked to use in schools (p. 53).

The other half, however, thought that a teacher needed to know a subject to a higher level to communicate simpler ideas. One of these students (Student D) said:

...as you should have the drive to find out as much as you can as it is what you have chosen to do, rather than just enough (p.53).

There was also little consensus among practising teachers as to the level of physics subject knowledge needed to teach the physics component in GCSE science. Heads of Physics in the local schools suggested every level from Year 9 Physics to 2 years of Physics post ‘A’ level - all receiving equal ranking. This study explored the topics in physics which experienced teachers find difficult to teach and contrasted them with the topics the student teachers *expected* to be difficult to ‘get across’ to pupils. Number mentioning a topic is N(t).

Teachers N= 21			Students (Pre-Placement) N=6		
Rank	Topic	N(t)	Rank	Topic	N(t)
1	Electromagnetic Induction	13	1	Inertia	3
2	Voltage (potential diff.)	11	1	Particle Theory	3
3	Circuit Calculations	10	1	Transistors	3
3	Transistors	10	4	Pulley Systems	2
5	Specific Heat Capacity	8	4	Temperature & Heat	2
5	Dynamo	8	4	Latent Heat	2
7	Mass and Weight	7	4	Magnetic Fields	2
8	Latent Heat	6	4	Electromag. Induction	2
8	Forces and Motion	6	4	Dynamo	2
8	Inertia	6	4	Transformer	2
11	Electrostatics	5	4	Diode	2
11	Logic Gates	5			
11	Floating and Sinking	5			

Table 3: Rank difficulty in teaching a topic – **Publication 1** p. 39.

In addition to subject knowledge, 21 experienced physics teachers were asked about teaching strategies that they considered were essential to physics teaching and, therefore, that should be a high priority part of the methods sessions. In priority order the key pedagogical areas of knowledge that they considered essential for any physics teacher were:

Teachers N= 21		
Rank	Topic	N(t)
1	Clear explanation	19
2	Clear aims for the lesson	17
3	Appropriate level	15
4	Work regularly marked	14
4	Pupils aware of 'rules'	14
6	Logical development	12
6	Control if Starts & ends	12
8	Work for all abilities	10
8	Use of names	10
8	Variety	9
10	Clear demos.	9
10	Materials requested	9
10	Good questioning	9

Table 4: Teachers' rank of importance of different teaching strategies – **Publication 1** p. 41.

Departments of Education in universities have often placed importance on the 'foundation' subjects (Sociology, Psychology and Philosophy)' However, student teachers, keen to learn practical aspects of teaching in the classroom, struggle to see their immediate relevance.

Student A said

I find the philosophical side difficult to associate with teaching. It is a waste of time really – you could get the information from books if you were interested (p. 57).

There have always been since the creation of the PGCE route into teaching, aspects of teacher professional knowledge to be considered by and developed in student teachers to enable

successful teaching. On the conventional one-year course, however, time for subject knowledge development is severely limited.

In the 1980s, continued professional development (CPD) of serving teachers was rare and ill-structured. This led to a rather ad hoc ‘back-pack’ approach in initial teacher education, which crammed pedagogy and as many related topics as possible into the initial teaching course, expecting this to last several years without further professional support. The concept of teacher professional knowledge was vague and rarely articulated clearly; an assessment of the extent and nature of the professional knowledge of student teachers rested solely in the hands of the colleges of education and was not often shared with school staff.

The empirical study and research techniques explained in **Publication 1** with student teachers of Physics were built upon and applied to an investigation of student teachers of Technology on the Open University PGCE (OUPGCE) in **Publication 2**.

In the early 1990s the idea of ‘Teaching Schools’ similar in concept to ‘Teaching Hospitals’ was promoted by HMI and the Council for the Accreditation of Teacher Education (CATE). Rather than student teachers being merely ‘loaned’ school classes to ‘practise on’, the schools were paid, and teachers were recruited to be mentors to support the student teachers. It became increasingly important that teachers were able to explain their practice and articulate their own professional knowledge when coaching these novice teachers. As illustrated in **Publication 1**, teacher knowledge is often tacit, and teachers found explaining aspects of their own practice difficult. Using the R&D paradigm, I investigated the nature of teacher professional knowledge which fed into the development of courses for teachers, both novice and experienced.

As OUPGCE students were working in schools across England, Wales and Northern Ireland, I visited 17 Technology student teachers in their homes and sometimes at school to explore with them what motivated these mature people to become teachers and, through discussion and classroom observation, teased out five aspects of teacher professional knowledge: 1) Subject knowledge, 2) Pedagogical Content knowledge, 3) Curricular knowledge and 4) ‘School’ knowledge, each strongly influenced by 5) their Personal Subject Construct. These empirical results were shared with colleagues in the Centre for Research and Development in Teacher Education (CRete). The outcome was the pictorial display of the results of the study as shown as Figure 1 from **Publication 2** which is in a format that could be shared with students and school mentors.

Building on the outcomes from **Publication 1**, the aspects of teacher knowledge represented in the diagram were developed through two interviews each with the Open University students of Technology or Design and Technology who entered the course from a range of different employment backgrounds. Both studies (**Publications 1** and **2**) emphasised the importance of subject knowledge, analogies and techniques to teaching – ‘pedagogical content knowledge’. It was on this aspect of the course evaluated in **Publication 1** that there was most disagreement amongst the students. Some complained that they needed the physics for the *classroom* – school knowledge - not just physics knowledge for its own sake. ‘School knowledge’ emphasises how a school subject sometimes gives undue weight to aspects of the subject that can be examined. The school ‘design process’, for example where a pupil is both designer and maker, is not reflected in technology outside the school.

This categorisation has been influential in research work done in Australia:

While Banks' (1996) ideas were related only to teacher knowledge, we suggest that versions of these same knowledges can be displayed and/or developed by other participants in technology classroom research episodes [Table 4]. In [Figure 1] subject matter knowledge refers to the knowledge teachers need to have of the content, such as materials, information and systems technologies. Pedagogical content knowledge refers to the "subject matter for teaching" technology (Shulman 1986, p. 9) (emphasis in original). It includes an understanding of the best ways to represent technology ideas to students; knowledge about ways that make those representations easy or difficult; and strategies to help students comprehend more easily. Curricular knowledge is knowledge of relevant mandated curricula. For example, in Queensland, Australia, this would be knowledge about the four strands of the technology syllabus [...] (Stein *et al.*, 2002).

Table 5: Examples of knowledges at work in technology classroom investigations (after Banks, 1996)

	EXAMPLES OF RESEARCH LITERATURE KNOWLEDGE	EXAMPLES OF RESEARCHER KNOWLEDGE	EXAMPLES OF STUDENT KNOWLEDGE	EXAMPLES OF TEACHER KNOWLEDGE
Pedagogical Content Knowledge e.g.	<ul style="list-style-type: none"> • subject specific strategies to organise learning • most useful forms of representation e.g. construction kits, demonstrations, • use of analogies, construction tips/techniques 	<ul style="list-style-type: none"> • subject specific strategies to organise learning • most useful forms of representation e.g. construction kits, demonstrations, use of analogies, construction tips/techniques 	<ul style="list-style-type: none"> • ability to recognise/develop technology understandings through the teaching strategies & representations used by the teacher 	<ul style="list-style-type: none"> • subject specific strategies to organise learning • most useful forms of representation e.g. construction kits, demonstrations, use of analogies, construction tips/techniques
Personal Constructs e.g.	<ul style="list-style-type: none"> • views of technology & technology education • views of teaching & learning • recorded experiences/studies in relation to use & development of technology • recorded experiences/studies of being taught & learning technology • intentions of research studies into design & technology education 	<ul style="list-style-type: none"> • view of technology & technology education • view of teaching & learning • past experience particularly in relation to use & development of technology • experiences of being taught technology related subjects • past research experience • intentions of research study 	<ul style="list-style-type: none"> • view of technology & technology education • view of teaching & learning • past experience particularly in relation to use & development of technology • experiences of studying technology related subjects • perceptions of what is valued about technology education shown through, e.g. the assessment program 	<ul style="list-style-type: none"> • view of technology & technology education • view of teaching & learning • past experience particularly in relation to use & development of technology • experiences of being taught technology related subjects • perceptions of what is valued about technology education shown through, e.g. the assessment program

Curricular Knowledge e.g.	<ul style="list-style-type: none"> • the structures & strands of national statements/ mandated curriculum documents • types of technology tasks & their purposes • published resources • established planning, teaching, assessing strategies 	<ul style="list-style-type: none"> • knowledge of structures & strands of national statement/ mandated curriculum documents • knowledge of published resources • knowledge of established planning, teaching, assessing strategies 	<ul style="list-style-type: none"> • response to the use of teaching resources & tasks • development of understandings about technology through the teacher's use of resources & tasks 	<ul style="list-style-type: none"> • knowledge of structures & strands of national statement/ mandated curriculum documents • knowledge of published resources • knowledge of established planning, teaching, assessing strategies
------------------------------	---	---	--	---

2.2b The contribution of the theoretical development and empirical verification of a revised summary diagram

As explained above, the developing research and modelling of teacher professional knowledge was refined and published as a journal article (**Publication 4**). This much cited work was used in the 2019 accreditation document for The Open University PGCE in Wales (Figure 7) to explain the approach taken by the university to the development of teacher professional knowledge. Figures 8 to 11 show how different subjects have used the model to illustrate how specific teacher professional knowledge applies to different contexts.

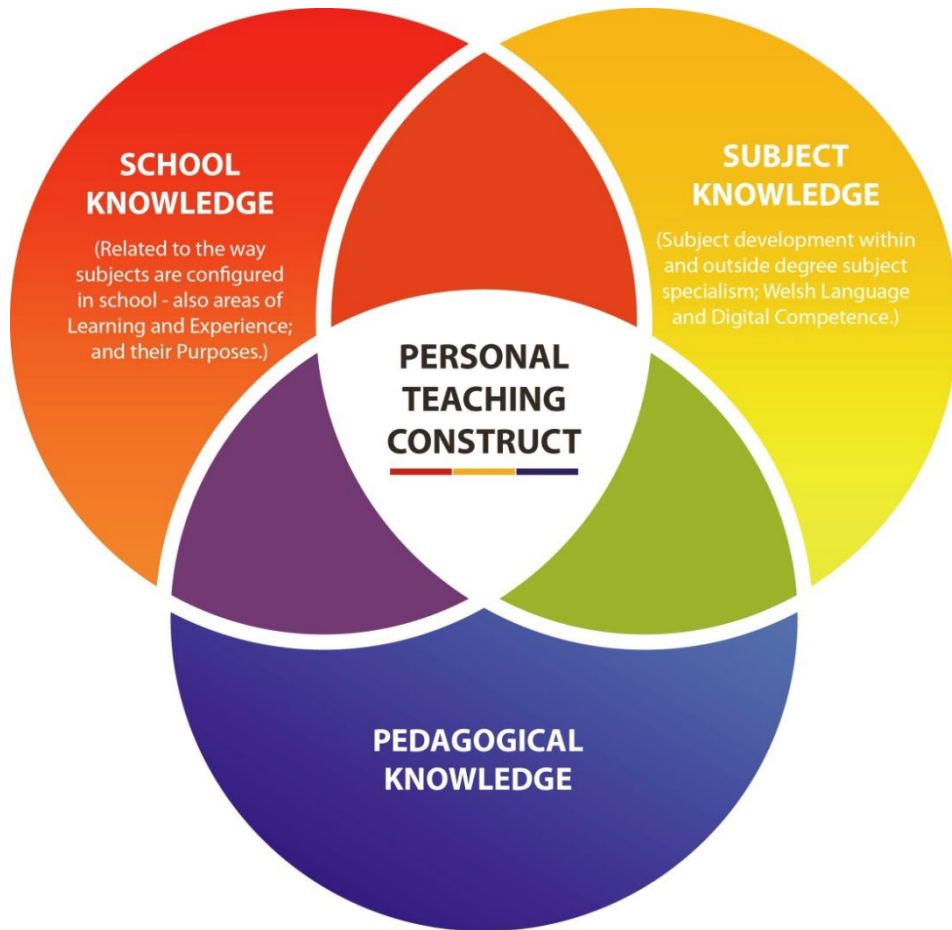

Figure 7: Teacher Professional Knowledge - Empirical work verified the above diagram as discussed in Section 2.1 Phase 2. This diagram was used in the 2019 accreditation document for the new OUPGCE in Wales.

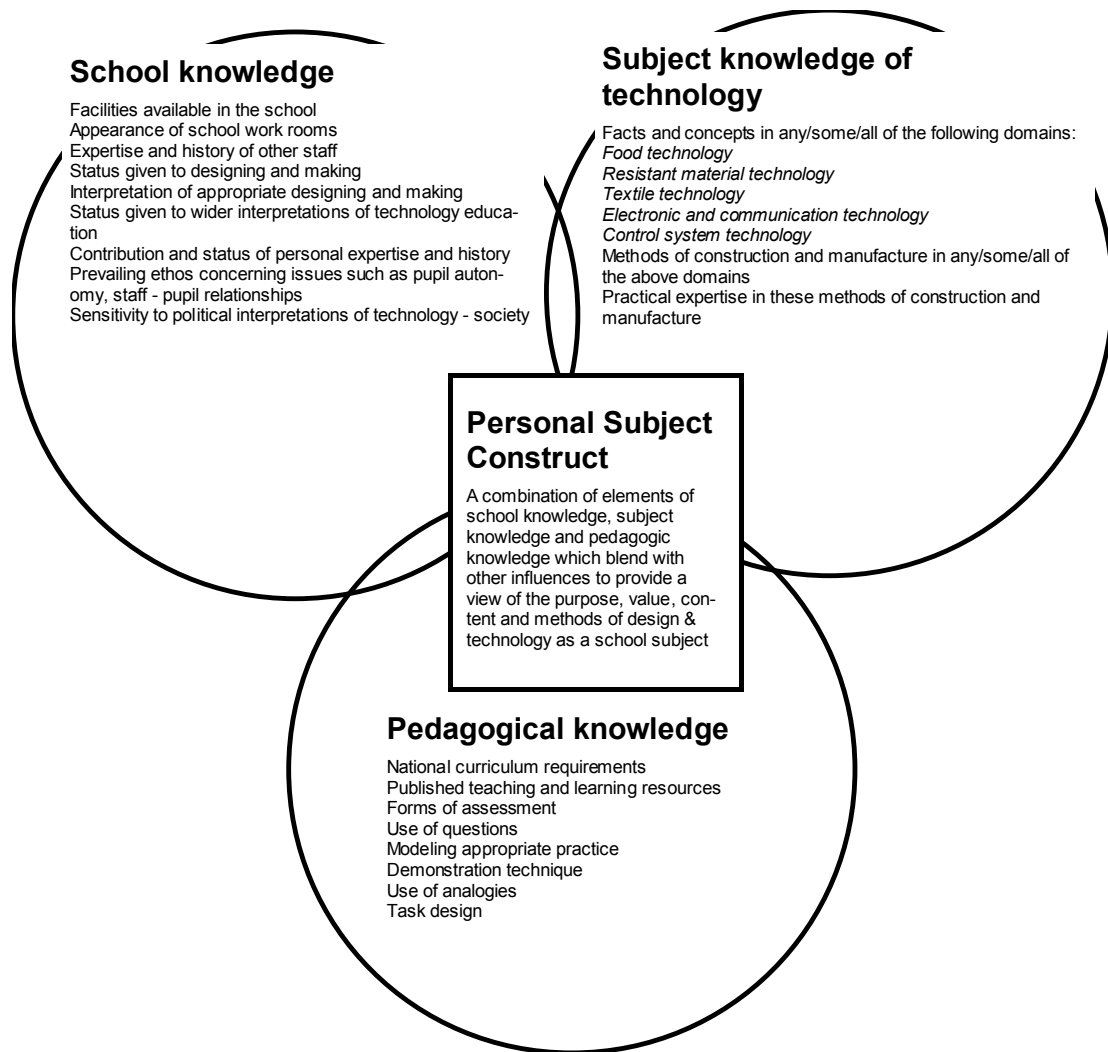

Figure 8: Example completed for design and technology in England (**Publication 5** p. 146).

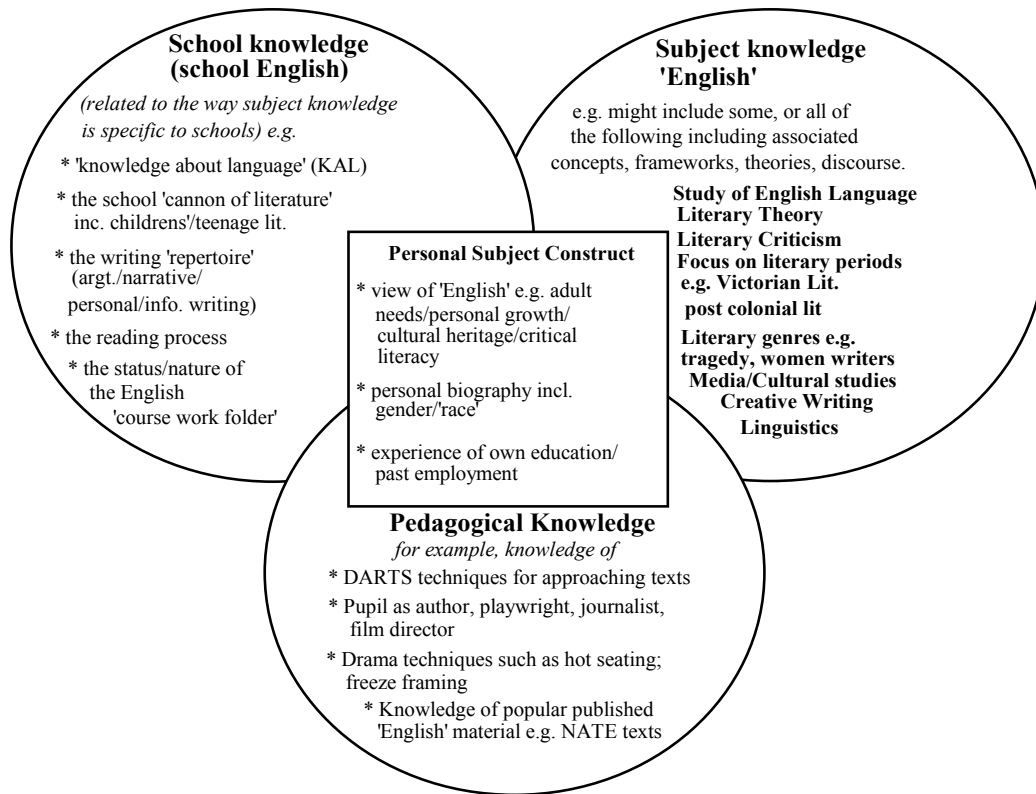

Figure 9: PGCE English student's designation of professional knowledge (Leach & Moon, 2008, p. 161).

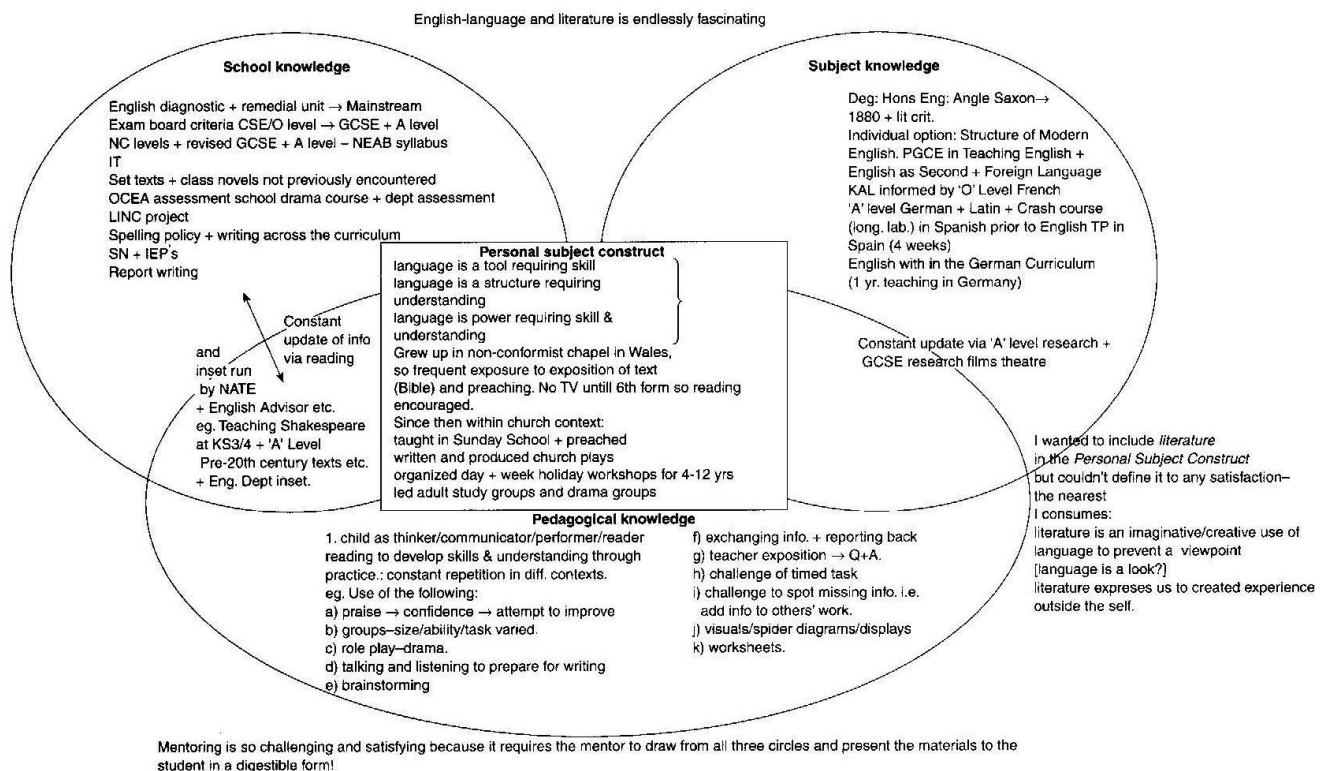

Figure 10: Mentor of English student's designation of teacher professional knowledge (Leach & Moon, 2008, p. 163).

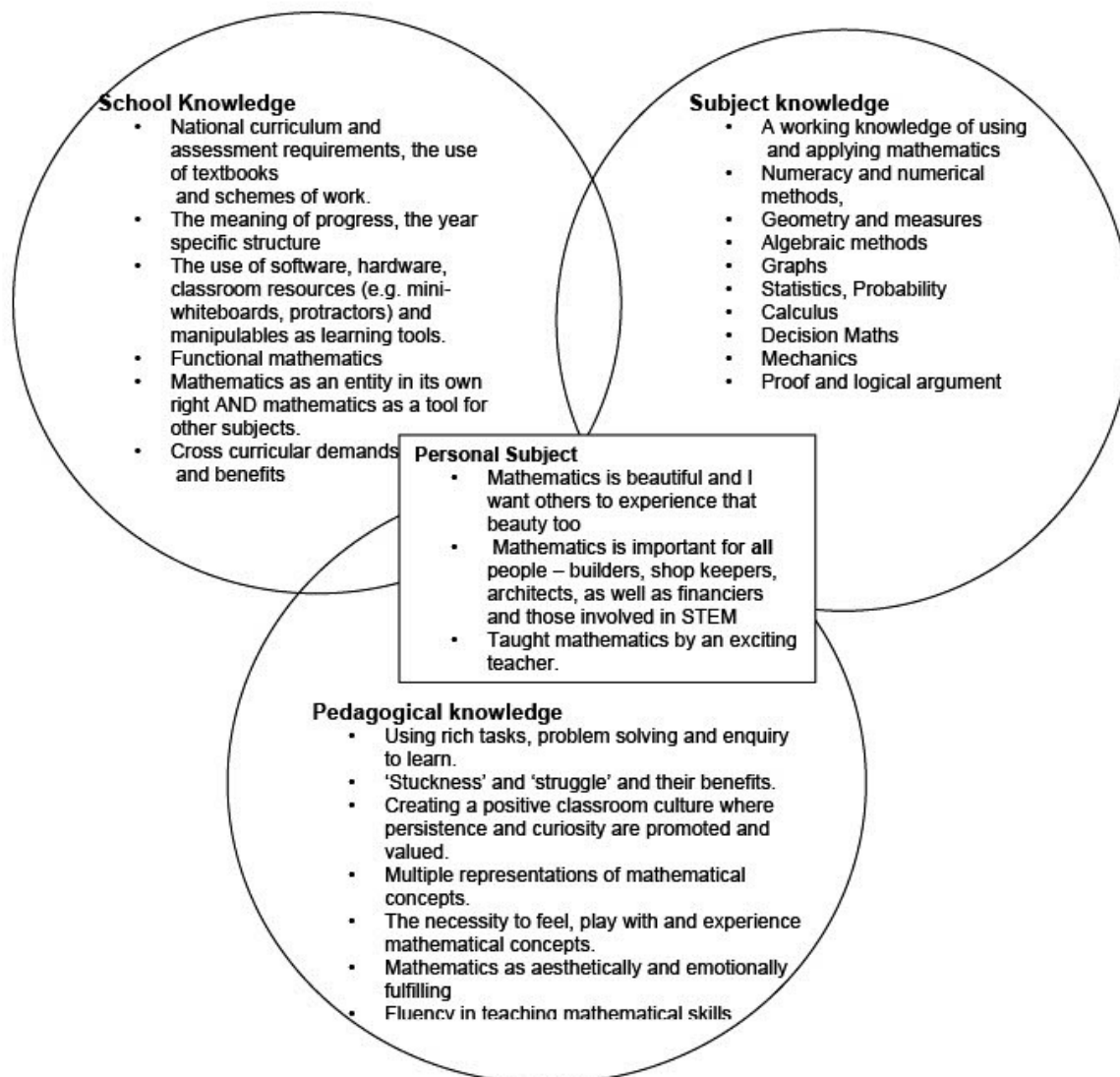

Figure 11: Mathematics teacher’s designation of teacher professional knowledge (Banks & Barlex, 2021, p. 37).

2.2c The contribution of the use of a Graphical Tool.

The graphical model of teacher professional knowledge developed in **Publication 4** and used empirically in **Publications 5** and **6** has influenced doctoral studies in Australia, Canada, New Zealand, Sweden and the UK, which all displayed and discussed the so-called ‘CReTE’ or ‘DEPTH’ model in detail and, using that basic structure, adapted the model to suit their particular needs. For example, in her PhD study of the professional identity of pre-service design and technology teachers MacGregor (2013) noted:

When devising a framework to enable pre-service, beginning and in-service Design and Technology teachers to reflect on their professional knowledge, the Centre for Research and Development in Teacher Education (CReTE) at the Open University of London (see Banks & Barlex, 1999, Banks, Leach & Moon, 1999) drew on both curriculum theory (Shulman, 1986) and cognitive theory (Gardner, 1983, 1991).

The conceptual teacher professional knowledge framework was originally developed to assist pre-service teachers to visually represent their understanding of professional knowledge and to assist them in considering aspects of their classroom practice.

The rationale in developing the model was the conclusion drawn from the research that establishing a shared agreement about teacher professional knowledge for Design and Technology could help pre-service and beginning teachers to reflect on their practice and facilitate informed discussion. For this reason, an adapted version of the framework was implemented in this study as a method for data collection (MacGregor, 2013, p. 48).

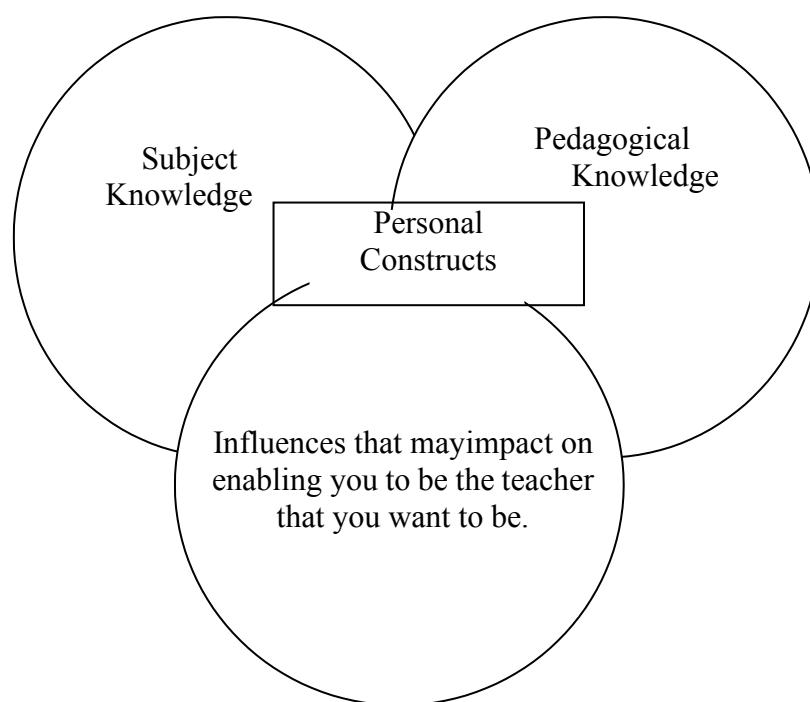

Figure 12: Use of teacher professional knowledge diagram by MacGregor (2013, p.78).

Similarly, in two EdD theses, Gill (2017) and Martin (2017) drew on the same framework.

Gill, when working with in-service teachers in the Canadian provinces of Newfoundland and Labrador, used **Publications 4, 5 and 6**, noting:

One widely utilized professional development framework in the technology education community is the Developing Professional Thinking for Technology Teachers (DEPTH) initiative. The DEPTH initiative uses the teachers' professional knowledge framework first articulated in a broad descriptive educational context by Banks, Leach and Moon (1999). Banks and Barlex (2001) later articulated this framework as a professional development tool specifically for helping develop the professional knowledge of technology education teachers. The framework as illustrated in Figure 1 is not a Venn diagram (F. Banks, personal communications, November 30, 2015); rather it illustrates how the realms of school knowledge (the culture of the school and how it effects the norms of teaching technology

education), subject knowledge (the technical knowledge about materials, processes, and building principles), and pedagogical knowledge (the norms of technology education pedagogy –open ended design problems rather than copying finished products thus possibly contradicting local school knowledge) overlap and support each other. The overlapping areas form the teacher’s personal subject construct or professional knowledge (Gill, 2017, p. 39).

[...]

This potential interaction within the conceptual framework is represented by interlocking puzzle pieces that connect the teachers to the areas of experiences, professional development and leadership. While these three areas are important constructs, they are not independent variables that can be pried from their context. To indicate this potential relationship, each of the three constructs are interlocked with each other to illustrate fluidity. This is meant to show that elements of each construct have the potential to affect other areas, and that they can overlap considerably within the context of an intermediate school, such as the case of Banks *et al.*'s (1999) personal subject construct (Gill, 2017, pp. 53-54).

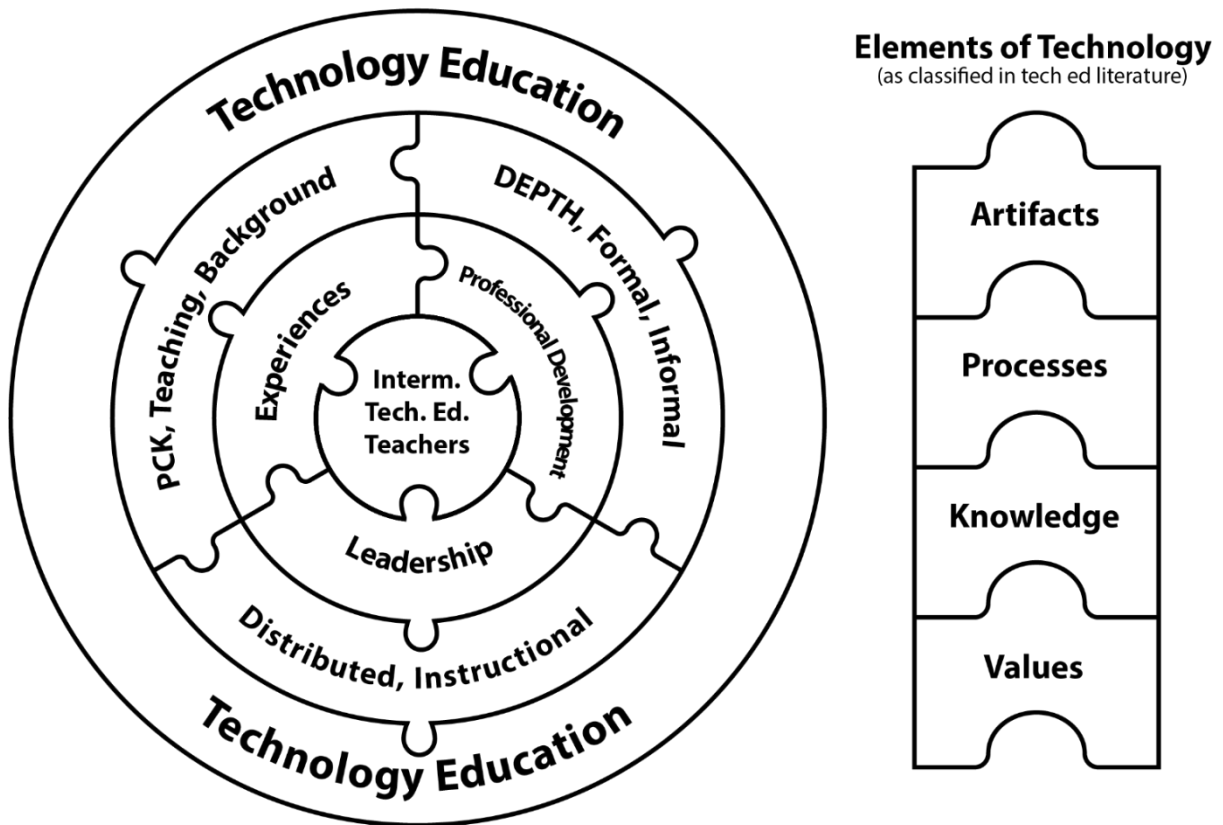

Figure 13: A conceptual framework for understanding the teaching of intermediate technology education in Newfoundland and Labrador (Gill, 2017).

The contribution of **Publication 6** to Doyle’s (2020) PhD is noted on page 13:

A significant contribution of the model lies in the emphasis placed on technology education, in that not solely the nature of the subject, but also established practices within a classroom environment unique to technology were presented. Although not explicitly concerning Pedagogical Content Knowledge (PCK), the DEPTH project (Banks *et al.*, 2004) in their investigation of technology teacher education students ‘personal subject construct’ identified significant variance in how participants conceived the role of teaching the same technology curriculum. Central to this study was the transformative nature of a personal subject construct, as it was identified to constitute more than the sum of its constituent knowledge

bases, school knowledge, subject knowledge, and pedagogical knowledge (Doyle, 2020, p. 13).

Lastly, Martin's (2017) EdD was a phenomenological study of pre-service teachers' subject knowledge in secondary design and technology. As in the other doctoral studies considered here, Martin displayed the DEPTH model shown in **Publications 5** and **6**, noting:

The DEPTH tool, as it was referred to, was used over a number of years and across a number of countries (Banks *et al.*, 2004) proving a useful way of helping pre-service teachers frame their experience. In relation to subject knowledge, a number of issues emerged from this research. Whilst this model was useful in framing beginning teachers' subject knowledge as part of their overall development it is, given the nature of knowledge, a simplification of a complex process.

The writing about the DEPTH graphical tool, and case studies of its use, has been significant within the subject domain and have clearly been effective in enabling pre-service teachers to reflect on their emerging role as subject teachers. The focus is on pre-service teachers experiences as a whole in comparison with the study being undertaken here which directly focuses on subject knowledge development and the influences that shape it. When looking at the research undertaken using the DEPTH tool, the pre-service teachers' comments related to the amount of subject knowledge they had and the gaps that they needed to fill. How the subject knowledge developed whilst on placement, and the factors affecting the acquisition of knowledge, were not covered in detail and this remains an area that is yet to be explored within the subject (Martin, 2017, p. 28).

Martin, however, was critical of the applicability of the graphical tool and concluded that it over-simplified what he considered a complex process. He argues:

Given the position adopted in relation to the nature of knowledge revealed in the study, and outlined above, it becomes apparent that attempting to create a pictorial model of subject knowledge, in the way that Banks and Barlex (2001) and Ellis (2007a) did, is a misplaced activity. This study has demonstrated that subject knowledge development for pre-service teachers is individual and affected by the contexts in which they have been working. For them, subject knowledge is anything but generic. To represent what has come out of this study with a fixed statement, or visual representation, of what subject knowledge is, would be inappropriate. Learning and teaching are dynamic processes affected by individuals and should not be reduced to simplistic scientific representations. Design and technological activity at its best is a dynamic interplay between materials, processes and human decision making that results in unique outcomes suited for particular individuals in specific contexts. It is a form of naturalistic activity best represented by narrative and other qualitative forms of representation (Martin, 2017, p. 154).

The view that in using the CReTE/DEPTH model the complex business of teaching is just being reduced to a simple diagram is not unique. Ellis (2007, p. 455) is also critical:

Most importantly, however, the graphical representation [...] downplays the collective, socially dynamic and historical conceptualisation of professional knowledge development that they begin elsewhere in their articles. In offering such as apparently individualistic graphical model they might also appear to be

suggesting that subject knowledge is less complex a category than the more obviously active and situated category of school knowledge.

Both Ellis and Martin, therefore, take issue with the place of ‘subject knowledge’ in the graphical model, but for different reasons. However, I believe that the use of the diagram as a tool to explore teacher knowledge *with* teachers (rather than a device to categorise such knowledge *after* working with teachers) moves the use of the tool from a professional development paradigm emphasising the acquisition metaphor to one that emphasises participation in the creation of knowledge; also, facilitating a consideration of what a teacher brings to the ‘dynamic interplay between materials, processes and human decision making’ enables a pre-service teacher to reflect on what they can do and what they still need to learn. It is indeed a unique outcome for each teacher, but to say that teaching is too complicated and that ‘subject knowledge is anything but generic’ sidelines subject-update courses that try to provide that additional subject knowledge for the necessary broad base of design and technology and of STEM.

Jones (2016, p. 34) in his PhD study draws on **Publication 5**:

In a study by Banks *et al.* (2004) excerpts, reproduced below, of teachers’ reports categorised as school knowledge show how school knowledge influences teaching:

“It is important that I discover the expectations within the department [...] My own teaching can then work around this” (Banks *et al.*, 2004, p. 150).

“[...] the department ethos, or approach to teaching was the same across the board. [...] The Projects from year 7 upward were very closed in nature and pupils led by

the hand through each assignment. This resulted in the pupils producing an end product identical to everyone else” (Banks *et al.*, 2004, p. 150).

“In this school the department is driven by the exam. That is all that is important. So I think technology here is too individualistic where industry is social” (Banks *et al.*, 2004, p. 150).

Looking to the wider design and technology research community, Stein *et al.* (2007) when working with in-service teachers in Queensland, Australia built on the diagram of teacher professional knowledge (**Publications 5 and 6**), explaining:

Banks and Barlex’s (2001) teacher education experience, and the professional development studies undertaken by Banks *et al.* (2004), and Jones and Moreland (2004) have highlighted the changes and challenges to teacher professional knowledges (Shulman, 1986) when technology education is introduced. For example, there has been recognition of the important place teachers’ personal subject construct knowledge has in underpinning the whole range of their professional knowledge about technology. Personal subject construct knowledge influences, and is influenced by, teachers’ school knowledge, or their understanding of how technology as a school subject is different from technology in the outside world; their pedagogical knowledge, in Shulman’s (1986, p. 9) words, “the ways of representing and formulating the subject matter that make it comprehensible to others”; and their subject knowledge or their understanding of technology as a field (p. 182).

The study of a professional development experience for teachers, reported in this paper, was underpinned by the model shown in [Figure 14], which is an integration

of the models of Banks *et al.* (2004) and Stein *et al.* (2000). By combining the two models (Banks *et al.*, 2004; Stein *et al.*, 2000), we attempted to devise a clearer, simpler model than the original model (Stein *et al.*, 2000) that would underpin and guide our interactions with teachers, as well as form a framework for data collection and analysis during the study. The combined model maintains the critical component of teachers' reflections on their own and others' conceptions of technology, on pedagogical knowledge and upon technological practices in accord with the recommendations of Banks *et al.* (2004) (p. 181).

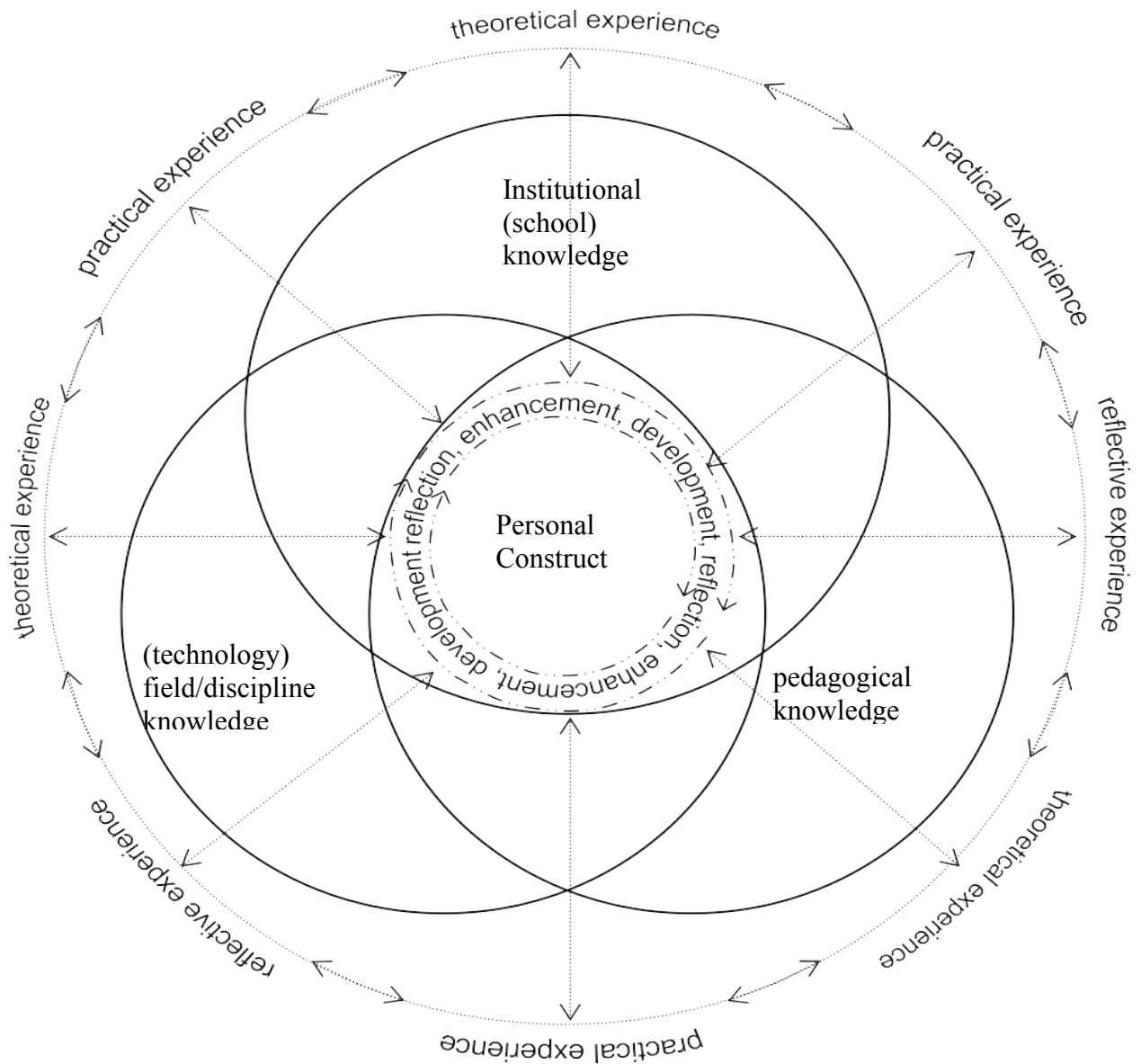

Figure 14: An integration of the models of Banks *et al.* (2004) and Stein *et al.* (2000) (Stein *et al.*,2007).

Stein *et al.*, just as in the study described in **Publication 5**, used the model as a discussion tool with teachers to help them articulate what is often otherwise tacit teacher professional knowledge. However, their diagram - said to be ‘a clearer, simpler model than the original model (Stein *et al.*, 2000) that would underpin and guide our interactions with teachers’ - must be the most elaborate development of the ‘CReTE/DEPTH’ model and consequently

rather *more* difficult to explain to teachers for their use. The theoretical roots of the graphical model explained in **Publication 4** gave the rationale for its development.

More recently Doyle *et al.* (2019a, 2019b, 2019c) in their consideration of ‘pedagogical content knowledge’ in teacher education draw extensively on **Publications 4 ,5 6 and 7**²⁹ to support their research. Some examples are:

Accordingly, practices have traditionally relied on the didactic transmission of knowledge, often being compared to the master apprentice model of the medieval guild (Banks 2008) [**Publication 7**] (Doyle *et al.*, 2019b, p. 145).

Over the past 30 years, the philosophy of D&T in various cultures has begun to somewhat align, and with a shift towards a shared agenda for D&T internationally came new understandings of what is of importance to student learning. Whereas vocational subjects were primarily concerned with the transmission of specific content knowledge and development of specific skills (Banks 2008) [**Publication 7**], D&T education is broadly characterised by its potential to develop transferrable knowledge, skills, and attitudes (Doyle *et al.*, 2019c, p. 475).

From a pedagogical perspective, D&T is said to be characterised by a pedagogy where there is no ‘right answer’ but rather different responses to the same problem are valued, some more than others (Banks *et al.*, 2004) [**Publication 5**] (Doyle *et al.*, 2019c, p. 477).

²⁹ Banks, F. (2008) ‘Teaching Design and Technology’ in Owen-Jackson, G. (ed.) *Learning to Teach Design and Technology in the Secondary School*, (2nd Edition) London: Routledge/Falmer, pp. 174-193.

And, focusing on the importance of subject knowledge Grobler and Ankiewicz (2021) point out that:

[t]eachers' knowledge about the structures of the subject matter influences the way in which they teach and therefore teachers who know more about a subject will be more interesting and adventurous in their methods and, consequently, more effective (Banks 2008) [**Publication 6**].

And setting out the unique aspect of Technology that challenges teachers' knowledge Grobler and Ankiewicz (2021) add:

Banks (2008) [**Publication 6**] viewed Technology as paramount among school subjects because it is characterised by a pedagogy where there is no 'right answer' but rather that different responses to the same problem are valued, although some are judged better than others.

2.3 Conclusion

In exploring **Research Question 1 (RQ1):** What are the elements of teacher professional knowledge and what is their inter-relationship? the outcome has been illustrated in three phases. In Phase 1, empirical studies of two-year PGCE physics students and of Design and Technology students on the 18-month Open University PGCE gave results that showed the importance of subject knowledge, relevant pedagogical knowledge and the need to focus on the subject's relevance to school, all mediated by the way a student teacher identifies with the role of a teacher. The nature of personal subject construct was found to be profound and was brought together with the other aspects of teacher professional knowledge in a summary

results diagram (Figure 1). The Phase 2 consideration of the literature surrounding pedagogy and pupil learning simplified the diagrammatic representation (Figure 4). This was particularly due to dissatisfaction with Shulman's suggestion that pedagogic content knowledge – analogies and explanations for a particular subject - is fixed. The revised diagram was checked empirically through further work with Design and Technology students. Subsequently the new 'graphical tool' was used in Phase 3 with a range of student teachers and experienced teachers in the UK and across a range of subjects. The tool was also shown to have a resonance internationally through the DEPTH studies.

The Research and Development methodologies used throughout the consideration of RQ1 in **Publications 1 to 6** has been a major contribution to new understandings of teacher professional knowledge not only across subjects but also across different teaching regimes internationally. The world-wide impact of this contribution to new knowledge is examined in Chapter 5.

Chapter 3 Theme 2: Developing Teachers of Technology

Research Question 2 (RQ2): In what ways can the suggested elements of teacher professional knowledge support the development of teachers of Technology?

7. Banks, F. (2008) 'Teaching Design and Technology' in Owen-Jackson, G. (ed.) *Learning to Teach Design and Technology in the Secondary School*, (2nd Edition), London: Routledge/Falmer, pp.174-193, ISBN: 0-415-46493-5.
8. Banks, F. (2009) 'Research on Teaching and Learning in Technology Education' in Jones, A. and de Vries, M. (eds.) *International Handbook of Research and Development in Technology Education*, Rotterdam, Netherlands: Sense Publishers pp.373-390, ISBN:978-90-8790-877-5.
9. Banks, F. R.J. (1996) 'Approaches and models in technology teacher education: an overview', *Journal of Design and Technology Education*, **1** (3) 197-211, ISSN 1360-1431.
10. Banks, F. and Shelton Mayes, A. (1998) 'High quality and new standards: an open learning contribution to the improvement of pre-service teacher education', *Paper at AERA*, San Diego, USA. April 1998.
11. Banks, F. and Williams, P. J. (2013) 'International perspectives on technology education' in Owen-Jackson, G. (ed.) *Debates in Design and Technology Education*, London, Routledge, pp. 31-48, ISBN 978-0-415-68904-5.
12. Banks, F. (2011) 'Technological Literacy in a Developing World Context: The Case of Bangladesh' in de Vries, M. (ed.) *Positioning Technology Education in the Curriculum*, Rotterdam, Netherlands: Sense Publishers, pp. 219-226, ISBN: 978-94-6091-674-8.
13. Banks, F. and Chikasanda, V. (2015) 'Technology Education and Developing Countries' in Williams P.J., Jones, A. and Bunting, C. (eds.) *The Future of Technology Education*, Singapore: Springer, pp. 217-238, ISBN 978-981-287-169-5.

Exploration of the second Research Question is also related to teacher professional knowledge but rather than focusing on the links between 'subject knowledge' and 'school knowledge', this chapter considers the 'pedagogical knowledge' needed for student teachers, and also the pedagogy developments needed for more experienced teachers, of Technology.

In part 3.1a, this chapter also considers how different types of teacher education programmes can be provided and, in particular, how they can be quality assured, especially if they use Open and Distance learning techniques. Part 3.1b considers technology education internationally, and also the particular challenges to teacher professional development posed in countries such as Bangladesh and Malawi.

3.1 Literature review of technology teacher education

Part 3.1a Teaching teachers of technology – the focus on pedagogy

Harrison (1993), quoted earlier (p. 47), laid out the historical changes in the contributory subjects that are now embraced by Design and Technology in secondary schools in England. The ‘designing and making’ using resistant materials now regularly includes textiles – such as in the design of a chair – and control technology and electronics with ever-more sophisticated components. McLain notes:

Modern design and technology foregrounds the role of design and creativity, introducing more expansive and pupil-centred learning activity, with the express aim of preparing pupils to participate successfully in an increasingly technological world [...] The processes of designing, making and evaluating through a practical ‘project’ are fundamental to the subject and our ‘signature pedagogies’ are informed by transformation and knowledge for action. [...] In Design and Technology, pupils transform ideas and resources into solutions (prototypes of products and systems), solving problems in response to human wants and needs in a real-world context. More important than knowledge about specific materials or processes is capability – knowledge of how to act purposefully in different situations. The nature of Design and Technology activity demands a repertoire of

pedagogical approaches, including those that are more restrictive (direct teaching and closed tasks) and more expansive (discovery learning and open-ended design activities) (McLain, 2021a, p. 208).

The ‘signature pedagogies’ or learning activities suggested by McLain are:

Designing and Making – typically through a design, make and evaluate project, with varying restrictions of context, time and/or resources.

Mainly Making – typically through focused practical tasks or projects, aimed at developing particular practical skills.

Mainly Designing – open-ended activities in response to a context or client brief, aimed at developing creativity and innovation.

Exploring Design and Technology in Society – typically critically reflecting or speculating, considering impact of choices, e.g., society/environment (p. 211).

McLain has built on and developed the learning activities set out in **Publication 7**, p. 183:

Design and Make assignments – which could be further divided into assignments where a pupil engages in a complete project which has been placed in a context created by the teacher, and more open assignments, where the complete task has been identified by the pupil.

Focused tasks – intended to help pupils acquire the knowledge, skills and values necessary for capability. There are many types of focused task, but all have a clear teaching intention.

As McLain notes (McLain, 2021a, p. 211), the impact of choices is important when ‘Exploring Design and Technology in Society’, and this consideration of aspects of society/environment was prefigured in Banks, 2006a, p. 210 (adapted from Layton, 1992 p. 36):

<p>Technical Pupils consider questions of “quality”; who is the product for? How should it be used and with what quality of finish? This is balanced against the extra time required for improvement.</p>	<p>Moral There may be a market for the product but given the responses to the social and environmental considerations—should it be made? Are people’s lives enhanced or diminished and how is that judged?</p>
<p>Economic Pupils should consider the idea of value for money or a thrifty use of resources.</p>	<p>Spiritual/ religious Is there a consideration of the technological Process and consideration of artefacts as to <i>who</i> should primarily benefit from the development?</p>
<p>Aesthetic Pupils should consider the quality of the images that are used in similar products and what that suggests about the user, the product, and its longevity in the market.</p>	<p>Social Is the product appealing to all or restrictive to just one sex or to the able-bodied? What impact does the product have on the way people behave? Who wins – who loses?</p>
<p>Environmental Is it justifiable to use materials for the product? “Where do the materials come from?” and “Where do they go?”</p>	

Table 6: Categorising value judgements – (Banks, 2006a, p. 210 – adapted from Layton, 1992 p. 36):

The left-hand side of Table 5 emphasises the ‘D&T criteria’ that are usually considered as part of the design process although those near the top often take priority over those near the bottom. Less common is consideration of the values set out on the right-hand, ‘Society’ side. These are promoted by those teachers and schools which have a strong commitment to ‘equipping pupils to become active collaborators in the creation of a more peaceful, just and sustainable society’(Pitt, 1991, p. 34).

Publication 7 looks at a number of teaching strategies and, in technology, the importance of demonstrating a skill or process:

A demonstration need not be a whole-class activity; sometimes it is better to demonstrate a particular technique or process to a small group or an individual who happens to need that skill. However, in balancing broader tasks, to encourage technological capability, with focused tasks, to give specific knowledge and skills, a whole-class demonstration may be the most straightforward course of action.

The best way to ensure you give a confident and accurate demonstration is to practise the procedure first. It is essential to go through the demonstration and ask a colleague to help you get it right, particularly if the technique is new or unfamiliar. Only by rehearsing the demonstration is it possible to ensure that it can be done and that there are no difficulties with the school's tools or equipment, either in supply or in use. It will also give you an idea of how long the demonstration will take (**Publication 7**, p. 176).

In his recent work McLain too sees a 'demonstration' as key (McLain, 2018, 2021b, 2021c):

The 'demonstration' is possibly one of the most common and important pedagogical approaches in design and technology teachers' pedagogical repertoire [...] Demonstrations are primarily used to develop pupils' practical skills, using a combination of explanation and modelling to 'show how' a procedure is correctly and safely approached [...] Therefore, it is essential for the teacher to be competent (i.e. have good subject knowledge) and manage the classroom skillfully in order

for pupils to undertake a guided activity (e.g. focused practical task) (McLain 2021a, p. 216).

Similarly in his consideration of teaching and learning in groups McLain (2021a, p. 218) points out:

Teamwork usually involves pupils collaborating on an external task over a period of time (e.g., several lessons) whereas group work activities tend to be short (e.g., a single activity within a lesson) on developing knowledge or as part of longer individual design activity. Working in groups poses challenges and can create tensions in the classroom and in curriculum design. Principally, there is the challenge of assessing work in groups and attributing contributions. Despite the benefits and rhetoric, teamwork is not widely utilised as a pedagogy in design and technology.

My earlier work (**Publication 8**, p. 386) has formed the basis of the work of others. For example, in his recent work McLain also finds:

Despite the rhetoric of technology lessons being an opportunity for pupils to work ‘as individuals and members of a team’, my observation of practical work is that the reality is pupils are more solitary in their learning. Although pupils are often given common design briefs and engage in similar preparatory activities, most of the time work is done on their own, and the later making stage is almost always done individually (McLain, 2021a, p. 219).

In his EdD thesis Brendan Anglim presents his findings concerning gender issues in the teaching of Design and Technology (Anglim, 2021, pp. 169-170), here abridged:

Theme	Findings	Theme	Findings
1. Teacher background	a. D&T can attract teachers from the quite disparate disciplines of art and engineering, both highly stereotyped gendered fields.	7. School restrictions	j. Art and D&T are perceived to be in competition as creative, project-based subjects and that the expressive creativity of Arts is gendered k. Participants perceive those other teachers providing guidance to pupils on their GCSE choices are poorly informed, make assumptions about D&T projectwork, creativity and attainment and that more girls are more likely to take on board that advice than boys.
2. Teacher gender	b. Women D&T teachers understand stereotype effects very differently from their male counterparts and the levels of understanding for male teachers is highly variable.	8. Attainment and failure	l. Participants suggest that the role of failure in iterative design and unknown project outcomes tend to be judged as having a greater attainment and cost value for more girls than boys.
3. Classroom relationships	c. The intrinsic value and enjoyment of girls and higher attaining pupils was negatively affected by 'rowdy' boys in their sets and some teachers' controlling behaviour management strategies.	9. Conscientious girls	m. Participants suggest that the conscientious approach to D&T often seen in girls is strongly associated with a fear of failure that can be traced back to male dominance.
4. Teacher models of society	d. Some participants hold gender essentialist beliefs based on faith and biology.	10. Practical confidence	n. The multiple functions of practical work, although recognised as a fundamental feature of D&T, is compounded by the participants' perspectives on D&T as an instrumental or general educational tool.
5. Professional boundaries	e. Participants' understandings of professional conduct standards and the way that they tackle gender stereotypes are interconnected. f. Participants reveal confusion between the legal responsibilities of positive action and discriminatory practices.	11. Contexts and specialisms	o. Participants firmly express their perception that girls in general are much less confident with forms of practical work than boys.
	g. Participants suggest that there are unprofessional teacher behaviours associated with the encouragement of pupils that do not place the		

	interests of the pupils first.		
6. Family guidance	h. Participants describe the pervasive and powerful effects of parental influence on limiting pupils' choices.		
	i. The influence of peers is downplayed by the participants, but older siblings and pupils are identified as powerful influencers.		

Table 7: Findings of a study of gender issues in Design and Technology (abridged).

Publication 8 (and **Publication 16**³⁰, p.222) considers gender in some detail and supports these conclusions, particularly 'm' and 'o' in the above table.

The work done in Germany and Britain illustrates gender differences in a number of areas. Girls have less experience with certain tools and measuring instruments than boys. Their hobbies are less likely to include using construction sets and they tend not to tinker with items around the home (Mammes, 2004). Murphy (2006) also noticed that the school experience of practical work is different for girls and boys, and teachers engaged in different levels of discourse especially in mixed sex classes. Contrary to what is thought about boys monopolising classroom time, in the workshop girls had more frequent and longer teacher contacts than boys. Randall (1987) found, however, that the requests were for help and encouragement, and the teachers rather accepted this position, reinforcing the girls' sense of inadequacy (**Publication 8**, p. 384).

³⁰ Banks, F. and Barlex, D. (2021) *Teaching STEM in the Secondary School: Helping teachers meet the challenge*, (Second edition), London: Routledge.

Publications 7 and 8 focus on the teaching and learning through authentic ‘real-life’ design-and-make tasks that is probably unique to Design and Technology education. Early considerations of models of teacher education exploited the categorisations suggested by the ‘teacher professional knowledge’ graphical representation discussed in **Publications 4**³¹ and **6**³².

In Part 3.1b I explore how the teaching strategies and pedagogic considerations set out in Part 3.1a can be operationalised.

Part 3.1b Teaching teachers of technology – the focus on course methodology

Publication 9 gives an overview of the different models and approaches to technology teacher education. Design and Technology, or as it is termed in Northern Ireland, Technology and Design, where ‘Design’ is emphasised, are subject titles particular to the United Kingdom. In many countries, and in early versions of the subject description in England and Wales the title ‘Technology’ was used as Information Technology was also a contributory subject. With its international breadth it is ‘Technology’ that is used in the following summary diagram (Figure 15). It draws on considerations of the purpose of technology outlined by McCormick (1993) and the range of school curricula in different countries set out by DeVries (1994). In summary, McCormick suggested four different types of justifications for why technology should be part of the curriculum:

1. The personal development opportunities it provides for students, for example practice in the solution of real problems and the associated thought processes, and

³¹ Banks, F., Leach, J. and Moon, B (2005) ‘Extract from “New understandings of teachers’ pedagogic knowledge”’, *Curriculum Journal*, Vol. 16 (3), pp.331-340.

³² Banks, F. (2008) ‘Learning in DEPTH: Developing a Graphical Tool for Professional Thinking for Technology Teachers’, *International Journal of Technology and Design*, Springer, Vol. 18 (3), pp. 221-229.

the multidisciplinary approach to knowledge and information essential to technology education. This is stated as a rationale for technology education in Australia.

2. Education for the technological culture in which we live, to enable students to become informed decision makers and responsible users of technology, not so much for their own sake but for the benefit of society, a significant rationale for technology education in South Africa.

3. The vocational dimension of technology education is a rationale that comes and goes with the passage of time and tends to correlate with periods of national economic depression when policy makers and industrialists turn to education as part of the solution.

4. Technology education as education for production was a strong rationale in many Marxist driven economies. With the collapse of the Soviet Union this rationale is less common but was a driving force in Eastern European countries such as Hungary, Czechoslovakia, the former German Democratic Republic, and southern African countries such as Zimbabwe and Mozambique.

(McCormick, 1993, p. 16)

DeVries (1994) proposed seven different approaches to technology education which have been cited in many contexts, including by Layton (1993) and by Black (1996):

1. A tradition in many countries has been the teaching of craft skills, often through the construction of set projects and the repetitive practice of relevant skills. This is a part of the basis of the Swedish tradition of Sloyd, which has influenced the

development of technical education in many countries and is still one of the approaches utilized in Sweden and in many parts of the UK.

2. In some instances technology education is organized along the lines of mass production, often in a business-like framework. Relevant skills relate to the use of jigs and fixtures, a production line sequence of activity, control and organization. This is utilized in some Eastern European countries and to a lesser extent in a manufacturing technology context in the USA.

3. Though generally rejected as appropriate for technology, it may be organized as ‘applied science’, where technology is used in the teaching and learning of science, as in Denmark. Sometimes technology gets down played where it is integrated with science, and is not dealt with as valid in itself, for example in the subject ‘Science and Technology’ in Israel and the emphasis of teaching Science, Technology, Engineering and Mathematics (STEM) as a combined approach in the USA and in England.

4. A focus on technology as exclusively high or modern technology, which is futuristic and emphasizes Information Technology. France, for example, and some of the learning modules in the USA and the ‘current technologies’ emphasis in England are inclined toward this approach.

5. Design, while a methodology of technology, may also be its organizational focus. In this case specific content is not so important, but rather there is an emphasis on the *process* through which students proceed in designing solutions to problems. Both the UK national curriculum and a number of approaches in

Australia have been criticized for this approach, and proposals for South Africa are inclined in this direction.

6. Technology may be structured as a series of problems to be solved, requiring information which is multi-disciplinary in nature. This is a common approach in parts of the USA.

7. The organization of content around the achievement of competencies is becoming a more common approach, evidenced for example in the ‘attainment targets’ of the Netherlands and the UK, the ‘competencies’ in Australia and ‘performance targets’ in Sweden.

(De Vries, 1994, p. 155)

These different rationales for teaching technology and the consequential teacher training methodologies are also set out in **Publication 11**.

The difficulty of acquiring sufficient subject knowledge needed for teaching technology, and particularly for the 2013 National Curriculum for England and the single-subject GCSE, was considered in Chapter 2 above. This breadth of knowledge when combined with the wider economic pull to other occupations of people with such knowledge and skills makes the recruitment of technology teachers particularly difficult. It is an international problem as indicated by Drew (2011, p. 77) in his consideration of the problem in the USA:

We need to

- Attract the best college graduates to teaching
- Provide them with meaningful education and training
- Keep them from leaving the position in despair
- Provide professional development for current teachers
- Respect these professionals to whom we entrust the education of our children and
- Pay them appropriately.

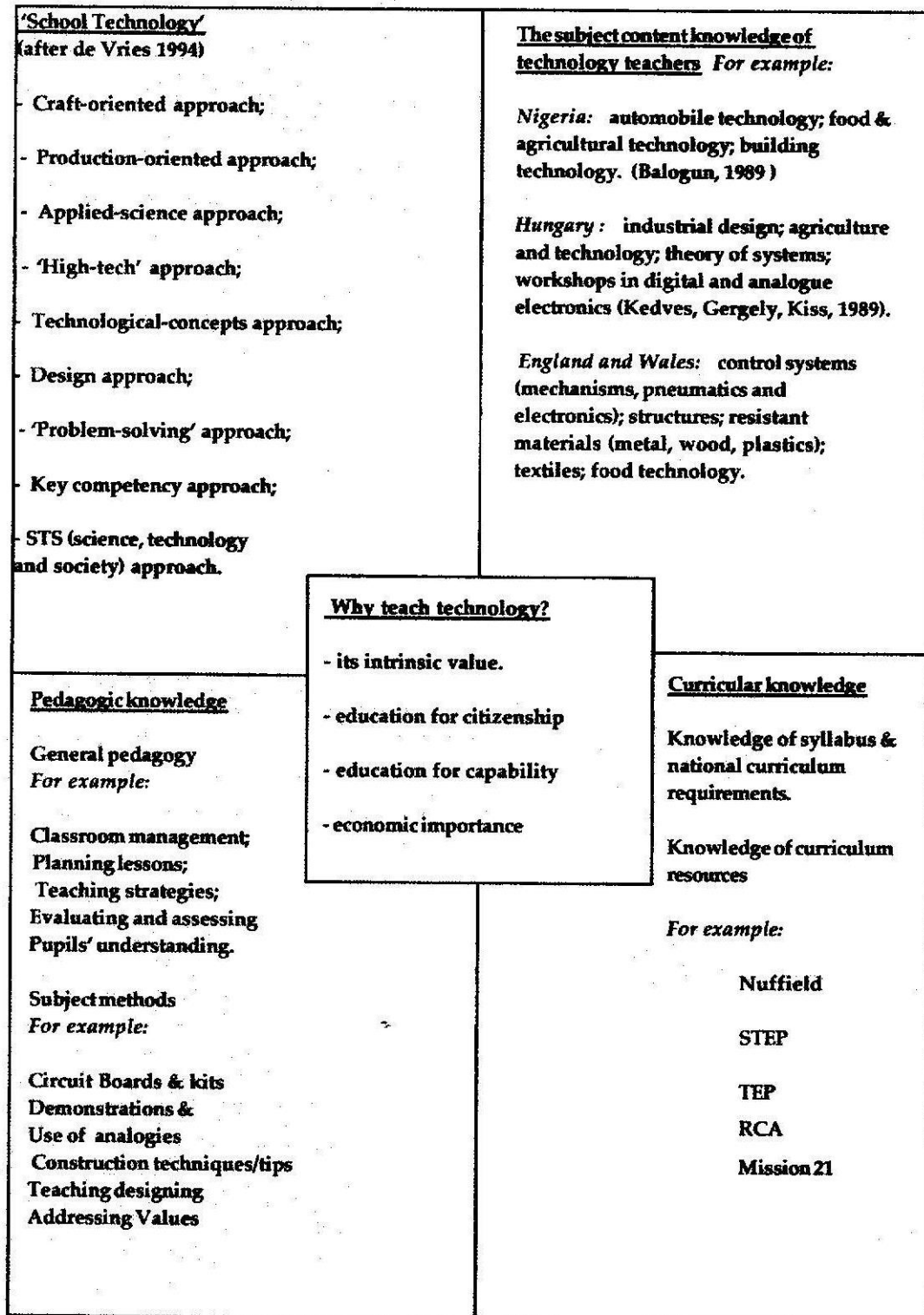

↑

Philosophy
Psychology
Sociology

Figure 15: Curriculum emphases which need to be addressed by whatever teacher professional development structure is in place. (Publication 9 p. 200).

Publication 9 considers two alternatives to workshop-based ‘bricks-and-mortar’ teacher education courses: mobile classrooms and open and distance learning.

A specially equipped bus, conveniently parked for local teachers, can become a mobile learning space with equipment suitable for a week of in-service teacher education. If it is close to a teacher’s school, activities can be tried out during the week as well as between visits. The British School Technology bus provided four separate weeks of teacher education. This strategy is still used in different world contexts.

During a training session in South Africa, I suggested that a train carriage could be attached to the Phelophepa Healthcare Train sometimes known as the ‘Roche Health Clinic’. The train has 16 coaches, and one could become a similar local in-service location for teachers. Such mobile classrooms were a successful in-service strategy that is still being used. For example, the IDEAS bus is a promotion of new equipment to schools:

New tech inventions come about every day. Does your team really need every piece of EdTech? Probably not. The IDEAS Bus allows you to get your hands on the most exciting solutions geared towards the students you care for, trial them on the spot, and understand the value they create before you make any decisions. Spend some time on the bus so you can spend your budget with confidence.

<https://theideasbus.org.uk/secondary/>

and

The Irish educational technology company, Wriggle Learning, have a so-called ‘Wriggle Roadcaster’, a mobile learning classroom that aims to help develop digital skills around the country.

<https://irishtechnews.ie/digital-learning-bus-launches-to-drive-technology-in-schools/>

Publication 9 also examines the use of open and distance learning for teachers of technology, including the Open University PGCE which began in 1994, the work done in South Africa by ORT-STEP, and the use of the then new technologies of computer conferencing using a telephone and modem and a rudimentary message board system called ‘FirstClass’.

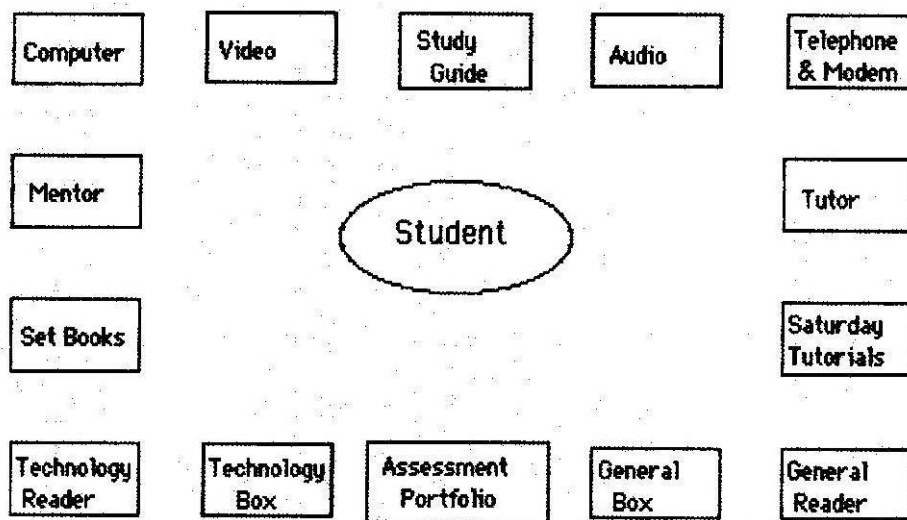

Figure 16: The resources available to a pre-service technology teacher following the OUPGCE. (**Publication 9**, p. 209).

This version of the OUPGCE followed a competence model which set out what was expected on graduation of the students. As school-based mentors were responsible for the classroom teaching assessment, a commonly agreed assessment framework was key (Banks, 2006b; 2009).

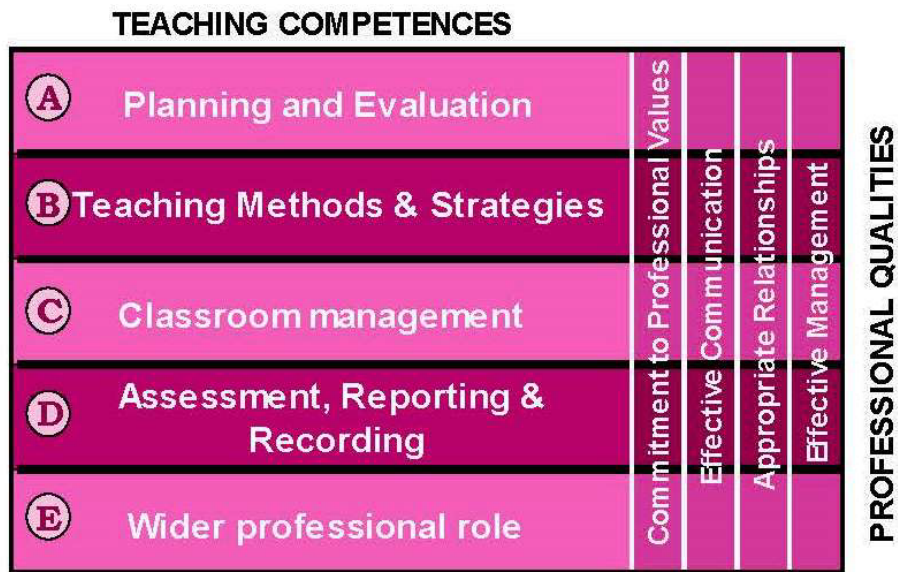

Figure 17: OUPGCE competence model (1994).

The idea of a competence model is not restricted to teaching. Other examples include competence in nurse education (Øvrebø *et al.*, 2022) and in exploring the digital competence of vocational teachers in Switzerland (Cattaneo *et al.*, 2022).

From the outset, the need for the OUPGCE to be accepted as a high-quality programme which can meet the needs of student teachers who due to their circumstances could not follow a ‘conventional course’, was paramount. **Publication 10** sets out (p. 4) the evolving quality assurance systems:

The quality assurance procedures linked to the programme have been refined through a continual process of evaluative research leading to the establishment of a set of key principles for assuring high quality in open and distance learning programmes. These principles are:

- explicit outcomes
- prescribed common frameworks

- triangulated evidence
- interconnected procedures
- systematic monitoring -indirect, direct and in response to structural 'triggers'.

The explicit outcomes are the assessment of competence criteria as shown in Figure 17. The common prescribed framework included a 'school experience guide' – a 'curriculum for the practicum'. What began as a simple guide to prompt a student to ensure they gained maximum benefit from their time in school proved to be a crucial tool in ensuring consistency in the teacher education process **Publication 10** (pp. 5-6):

The variability of school context and national coverage requires a tightly prescribed framework that all involved in training and assessment 'sign up' to. This provides an entitlement to training and assessment for students and sets the criteria by which internal and external monitoring is carried out.

The common prescribed framework extends to: centrally produced but regionally delivered training programmes for assessors; a distance learning "Mentor Training Programme" which supports the mentor and the school co-assessor; an assessment reporting framework for mentors and tutors; detailed school-based assessment activities structured through common school experience guides and assessment guides; and a structured professional development portfolio of evidence structured by the competence and professional qualities model.

The success of the OUPGCE and its development over the years led to a 2010 inspection result of 'Outstanding' in Northern Ireland and the same grade being awarded following the 2011 OFSTED inspection in England. Similar open and distance learning techniques have been used in Bangladesh, Sub Saharan Africa and India, where independent evaluations have

shown that central to the success of open learning for professional development is that the learning takes place in the teacher's own work context. Exclusively centre-based teacher education programmes remove a teacher from the classroom to travel to a teachers' centre for two or three weeks, 'give them the training', and then:

“Right, you are trained, now go and apply it in the classroom!” They just don't work. They are expensive, and they don't work. Much more successful for professional development is activity that requires a teacher - or even better a pair of teachers - to follow an open and distance course in their *own* classroom, try out something new and share it with their colleague, and then meet up for local teacher 'cluster meetings' to discuss how well it went. It is a very successful model to encourage teacher professional change (Banks, 2011).

The use of communications technology to link OUPGCE students together using the 'FirstClass' message-board software was innovative in 1994. Using new technology for teacher education 'at a distance' became an important R&D process (Banks, 2001, Banks, Moon & Wolfenden, 2009).

In January 2004, The Open University in collaboration with the BBC launched a wholly on-line continual professional development (CPD) environment for teachers, teaching assistants, school librarians and school governors, known as TeachandLearn.net. The creation of this subscription website was the culmination of the many lessons learned from a series of pedagogical developments at the University in on-line technologies for teachers. Starting with the use of 'FirstClass' informed the Learning Schools Programme in 1999 (a UK government funded initiative to improve teachers' confidence in subject teaching using computers) which in turn informed the development of the revised *flexible* Postgraduate Certificate in Education

which could be started at a point that recognised the prior teaching background of the applicant and taken at a pace that suited the applicant’s circumstances. Launched in 2002, it owed its extreme flexibility to its on-line nature. It was the most Open course in the Open University. The different programmes – or ‘Developments’ – were based on evaluation lessons learned from the earlier teacher-education courses (see Figure 18).

Demonstration of the R&D journey with on-line teacher education environments:

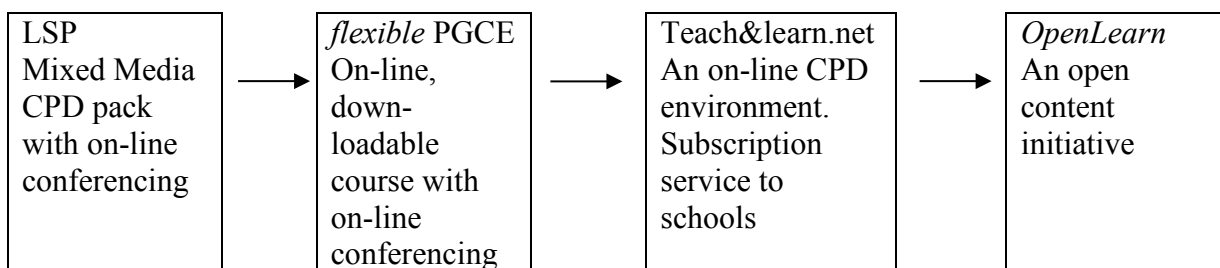

Figure 18: Synthesising the teacher professional knowledge and CPD on-line pedagogy

Figure 19 is a screen shot from the science area on TeachandLearn.net which illustrates how the different aspects of teacher knowledge researched in **Publications 2**³³ and **4**³⁴ have been developed for use in the design of this on-line CPD environment.

³³ Banks, F.R.J. (1996) ‘Developing professional knowledge during initial design and technology teacher education’, *Journal of Design and Technology Education*, Vol. 1 (2), pp. 175-178.

³⁴ Banks, F., Leach, J. and Moon, B (2005) ‘Extract from “New understandings of teachers’ pedagogic knowledge”’, *Curriculum Journal*, Vol. 16 (3), pp. 331-340.

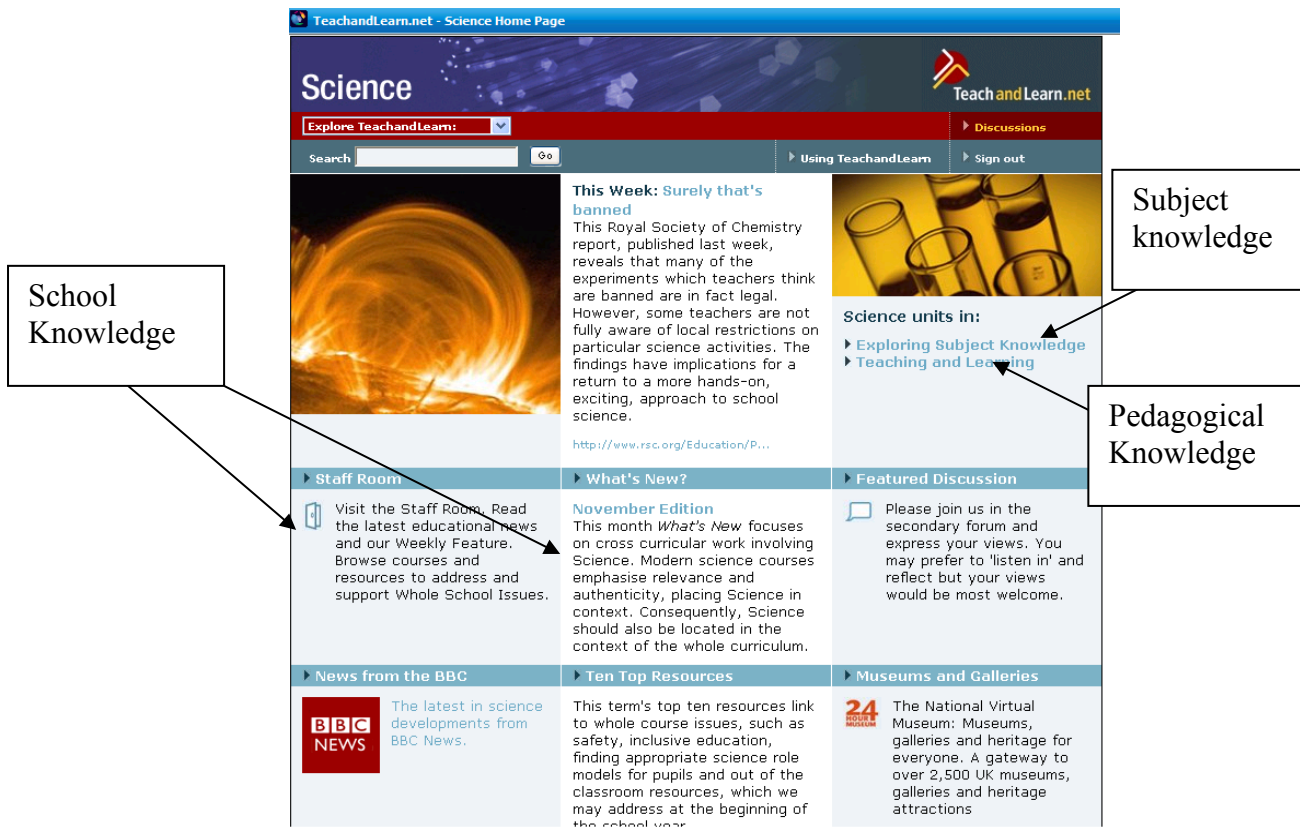

Figure 19: Screen shot of the TeachandLearn science ‘homepage’

TeachandLearn.net was the third major on-line teacher education programme offered by the Open University since 1998. Following the Research and Development approach, lessons learnt from evaluation studies on one programme, such as the Learning Schools Programme (LSP), fed into the next both in terms of practical techniques and in substantive research. (See Fig. 18)

These are the outcomes – the ‘Development’. What has been learned from the ‘Research’?

The Learning Schools Programme

The Open University’s Learning Schools Programme (LSP) had a focus on better teaching by the use of ICT in the classroom/workshop and provided teachers with a broad range of

professional tasks, supported by a mixture of print, on-line and face-to-face support, including:

- a printed 'teachers guide'
- a multimedia 'CD-ROM'
- a printed 'Teaching your subject' booklet.
- national and local on-line, asynchronous 'Conferences' (like the original FirstClass)
- face-to-face and on-line support from specialist 'Teacher Advisers'.
- a subject web site.

Over the life of the project, well over 160 000 teachers engaged with LSP; significant numbers (approximately 40 000 across all subjects) shared on-line ideas, resources and collaborative planning. Teachers working together in such a community of practice, using text-based asynchronous computer conferencing, can share understandings, classroom experiences and pedagogical insights.

Within the flourishing on-line CPD computer conferences, LSP faced the logistical problem of welcoming those teachers new to the programme who had to be quickly brought into an existing 'room' colonised by 'old-timers'. Research on how teachers engage in on-line professional development (Zenios, Banks & Moon, 2004, p. 133) suggested that on-line teacher conferences are influenced by three context factors:

- the way in which e-conferencing is organized within the context of a formal course.
- the contrasting character of subject domains.
- the length of engagement of the participants in e-conferencing.

The last factor, in particular, influences the participants' transition from novices to more experienced users of e-conferencing. Key dimensions of this transition are:

- the formulation of on-line relationships among the participants.
- the visualization, by the participants, of the on-line event.

Within successful e-conferences, teachers' professional development can be stimulated in new ways, through developing communities of practice and through creating new forms of reflection within e-conferences. The role of the moderator is crucial in stimulating effective e-conferences that develop reflective practice and learner autonomy. The moderator's role, in particular, is in forming the electronic community of practice through structuring the learning resources of the community (Kyriakides-Zenos, Banks & Moon, 2002, p. 274).

The open learning materials developed for the Learning Schools Programme also needed to be updated, and good ideas suggested by teachers themselves or witnessed by academics making quality assurance visits to schools, needed to be shared across the community.

As discussed at the beginning of Section 1.4, the classic Open University production systems adopt an industrial model for course design and production. A large resource (often running into millions of dollars) is spent in the development of highly illustrated books, TV programmes and multi-media materials. Over the five-year life of the course, thousands of students use and pay for that initial outlay through their course fees. Set-up costs are very high, but marginal costs are very low, so a programme can double its student population very easily.

With on-line development and delivery, a hybrid model is possible, allowing some set-up resource to be held back for responses to later suggestions or subsequent changes in government regulation that are either impossible or highly expensive to achieve through a traditional print-based programme.

The *flexible* OUPGCE

The initial teacher preparation course from the Open University launched in 2002, the *flexible* PGCE, was almost entirely taught on-line. Using a combination of e-conferencing, downloadable text modules (in pdf) and web-links, a student was able to have a course tailor-made to their personal circumstances and prior experience. This was, and remains, unique in teacher education and was only achievable due to the way open and distance learning moves the fixed time and place for teaching of traditional ‘bricks and mortar’ institutions, to a time and place for study that suits the student, and with the added benefit that the menu of modules to be studied is created specifically to suit the needs of the individual.

Using an initial on-line needs analysis process based on the model of teacher professional knowledge set out in Theme 1 (**p. 62**) and discussed in **Publication 4**³⁵, depending on their subject knowledge, and prior school or equivalent pedagogic knowledge, students could be offered the equivalent of a full year’s conventional preparation, or two-thirds, or one-third of such a course; or if they were very competent but did not have ‘qualified teacher status’ (for example, if they were teachers in private schools, or had trained outside the UK), an ‘assessment-only’ route was possible too. In this way open learning was, for the first time at the Open University too, breaking out of the constraints of time to embrace variable course-

³⁵ Banks, F., Leach, J. and Moon, B (2005) ‘Extract from “New understandings of teachers’ pedagogic knowledge”’, *Curriculum Journal*, Vol. 16 (3), pp. 331-340.

lengths, and away from a ‘one-size-fits-all’ approach to teacher development. This unique development was widely praised. For example, the Northern Ireland inspectorate concluded that the course was ‘Outstanding’ and:

The strengths include:

[...]

- the management arrangements, which meet effectively the individual needs of the students;
 - the rigour of the selection procedure and the initial needs analysis process;
- (ETI, 2010, p. 2)

Although the different students were directed to select the web-based units pertinent to their individual needs, all students knew that they had to achieve the same common set of required learning outcomes determined for all participants at the start. The eventual outcome of the design of the *flexible* PGCE is a principal result addressing Research Question 2.

TeachandLearn.net

TeachandLearn.net combined a range of features used in both LSP and the OU *flexible* PGCE. Schools interested in obtaining access to the professional development site subscribed at a rate depending on the size of their school. Teachers logging on with their own individual passwords were offered a tailor-made environment appropriate to their declared subject specialisms and interests. As with the PGCE they could select from a range of downloadable text-based resources, weblinks and audio-visual elements to suit their needs. All subjects followed the same template of twelve so-called ‘web-units’ which were developed out of the web environment designed for LSP. The authoring brief for the web

units also reflected lessons learned from LSP and the *flexible* PGCE – that the unit should be relatively short and the writing tight, erring on the side of journalistic clarity rather than academic circumspection. Similarly, the design of the web units sought to clearly present on each screen *the activity* (what to do), *the narrative* (why it matters) and *the resources* (things to help you do it).

The web-unit template, a cornerstone of the former Learning Schools Programme (and similarly of OUPGCE modules) gave a degree of uniformity to what is the formidable logistical challenge of developing so many web pages with exciting and relevant ‘assets’ such as images, articles, audio-visual resources and appropriate supporting web-links, with copyright all cleared for use. The template also provided a common structure, so that when teachers had become familiar with one ‘web unit’, they could quickly ‘read’ the structure of other units – in a similar way to how we ‘read’ the structure of a newspaper, quickly skimming and locating the information that is relevant to us each day - because although the news changes, the format remains broadly the same.

As is shown in Figure 18, the content of the TeachandLearn.net site was based on research into earlier on-line teacher professional development, but it was unsuccessful. Why was that?

An independent evaluation carried out of CPD in a range of schools - some who subscribed to TeachandLearn.net, some who knew of it but did not subscribe and some who did not know of the site at all - provided very useful insights to the success and difficulties that were encountered with such early use of new technologies for teacher development.

Investigating teachers' use of on-line CPD

In April 2005, the market research firm NOP Social and Political was commissioned to investigate the take up of TeachandLearn.net (T&L) from both those who had subscribed and those reluctant to do so. Mixed quantitative and qualitative methods were adopted using an on-line questionnaire approach and follow-up interviews in a 'consecutive' research design as discussed in Section 1.4.

Quantitative

A 10-minute oral questionnaire using a 'Computer Aided Telephone Interview' technique was conducted with teachers in schools who had responsibility for CPD. The breakdown of schools was as follows:

- 400 computer telephone questionnaires:
 - 204 primary schools
 - 196 secondary schools
- Size of school:
 - 49% up to 250 pupils
 - 24% 251-500
 - 27% 501+

	Primary schools	Secondary schools	TOTAL
Purchasers	23	27	50
Considerers	73	77	150
Unaware	108	92	200
TOTAL	204	196	400

Table 8: School break-down in Quantitative study

Qualitative

An in-depth interview lasting one hour was carried out with 16 teachers as follows:

	Secondary Schools	Primary Schools	
South West	1	3	
North West	4	2	
South East	2	4	Grand Total
TOTAL	7 1 already purchased, 6 approached only	9 3 already purchased, 6 approached only	16 4 already purchased, 12 approached only

Table 9: School break-down in Qualitative study.

The questions asked were intended to address the following aims:

- To establish what CPD actually means to respondents at the school level, in terms of current priorities, processes and behaviours
- To gauge spontaneous awareness of TeachandLearn.net and/or other forms of CPD that T&L is competing against
- To assess what people at the school level really want to achieve via CPD, current learning needs and levels of motivation
- To gain more insight into the broader context and climate for CPD and practical issues such as budgets, accreditation, and ICT
- To gauge reactions to TeachandLearn.net – perceived merits and barriers - based on publicity and marketing [for all respondents] and on experience of the site in practice [for those respondents in subscribing schools]

Summary of findings from survey

One key finding from this work was the very wide range of views as to the *nature* of CPD. Many saw it as a rather nebulous concept. Some quotations from these senior school staff illustrate this.

“If you’ve learned something you didn’t know before, that’s CPD”

“What do you mean by CPD? Do you mean training?”

“Two years ago, most people wouldn’t have heard of CPD – indeed I hadn’t”

Both the quantitative and qualitative data indicated that schools were then in the middle of a process of transition from a previous vocational model of CPD where teachers volunteered and attended courses for training to a more corporate approach addressing a school’s particular needs. At the same time as this transition occurred, there was evidence of hurdles to be overcome before schools were ready to contemplate take-up of in-school, and particularly on-line CPD, namely:

- Slow rate of transition to a more corporate-style management model
- Need for achievement of critical mass in ICT provision and skills
- Information overload, with few reliable filtering criteria
- Lack of time and opportunity for senior staff to think strategically

However, there was some evidence that schools were resolving these issues.

Lessons Learned from TeachandLearn.net

Despite the extensive research and development that took place in creating the TeachandLearn.net, the NOP research indicated that a number of challenges faced the programme which ultimately were too difficult to overcome:

- Classroom culture

The reluctance of teachers to change the classroom practice which currently seems to work for them is a challenge to any in-service programme whatever the model or mode of delivery. If a school is to re-subscribe, school managers will want to see

some effect and the benefits of a substantial CPD site such as this may not offer improvement as a 'quick-fix'.

- Tips or professional development

There are many existing web-environments that offer classroom resources or lesson plans 'off the shelf'. TeachandLearn.Net was *not* a 'tips for teachers' site', but it tried to strike a balance between challenging existing practice and offering activities that could be easily and quickly tried out by teachers in school. The focus of what is wanted appears to be practical, hands-on support that will affect delivery in the classroom.

- Learning via the net

Will teachers accept on-line learning? Before MOOCS and similar on-line courses, those users who were actively adopting TeachandLearn.net praised it enthusiastically; however, there was still a perception of it being then very early days, both for the product and for purchasing schools.

The impact of ICT and its promised revolutionary effect on teaching and learning have been over-hyped since the introduction of the first simple PCs in that late 1970s. However, the way that the World Wide Web opened up access to knowledge and information started a cultural change that impacted on schools and on schoolteachers as much as anyone in the community.

The survey of schools concluded that TeachandLearn.net was in principle in the right place at the right time - particularly if it could create a more direct relationship with CPD heads / coordinators. However, the University came to the conclusion that the subscription service business model was not working and withdrew the site in summer 2006.

The Open Content Initiative – OpenLearn. (<https://www.open.edu/openlearn/>)

Launched in October 2006 with support from the William and Flora Hewlett Foundation, OpenLearn made a selection of the University's high quality open educational resources freely available on-line. There were originally two linked sites the 'Learningspace' and the 'Labspace'.

The Learningspace was designed for learners, whatever their educational needs and experience, and courses can be studied by individual learners or by organised or self-organising groups. Key features include:

- units of between 3 – 15 hours of study time on specific topics, the equivalent of an evening's through to a week's work
- learning outcomes for each unit and self-assessment activities
- discussion forums to enable learners to engage with peers and blogging tools to publish thoughts

These resources were extensively used by parents 'home schooling' during the school lockdowns in the 2020-22 Coronavirus pandemic.

The LabSpace was designed for educators. It offers a more sophisticated range of sense-making tools to complement the resources from The Open University and elsewhere. Users can:

- access more experimental versions of the university resources
- enrich and re-develop existing open educational resources
- influence and participate in development of new units or new versions of units
- upload and share personal open educational resources they have developed

- find other users with shared interests or specialist knowledge, and interact with them via video conferences, video blogs and enhanced instant messaging.

In the Labspace educational practitioners could combine Open University units with material from their own sources under a flexible Creative Commons copyright licence. In 2022, over 5,000 learning hours of content are available on-line.

The successful OpenLearn was extended to a similar but more extensive platform for universities across the world called FutureLearn (<https://www.futurelearn.com/>) and the notion of ‘micro-credentials’ to demonstrate satisfactory course completion.

R&D and teacher education

It was clear that on the journey to that latest e-learning offering from the Open University some key lessons were learnt.

- When schools are the site of learning, change in classroom practice is profound. Open learning techniques are excellent in bringing new ideas into the classroom (Banks, 2011)
- High quality content became cheap. A model was developed that made knowledge freely available, at least in part, but charged for assessment and support.
- Teachers need help to change their practice. A degree of ‘hands-on’ support from such people as teacher advisers, or for teachers to come together in local ‘cluster meetings’, is necessary to effect classroom change. School leaders need help to support in-school CPD.

- Teachers using on-line tools can become a community of practitioners that can support one another, bring good practice into school and yet reduce the time that teachers are away from their pupils.

As a showcase of material from the Open University, OpenLearn contains material from LSP, the *flexible* PGCE and TeachandLearn.net. The site not only learned from these initiatives but has embraced them as content. The use of mobile phones, particularly in developing world contexts, enabled teachers to have a CPD course in their pocket (Shohel & Banks, 2010, 2012). A particular lesson learned from the use of new technologies was the use of *appropriate* new technologies. The ‘CPD in the pocket’ could be a phone; in almost all developing countries, a schoolteacher has a mobile (cell) phone.

Part 3.1c Teaching teachers of technology – the international context

As discussed above, the creative designing and making area of a school’s curriculum has different names in different countries, and different roots of development. What has developed over the years, and what is possible in the future, is enabled or constrained by a country’s wider school systems. Some countries have a very well-established vocational school strand with different traditional expectations of the purpose of a technology curriculum, compared to the general schools. Many, perhaps most, current technology curricula have their roots in the craft tradition where the production of ‘quality products’ was paramount. Some have had a design element included for many decades. Some curricula exist as a spin-off from an applied science approach, and even if not formally considered part of STEM (Science, Technology, Engineering, Mathematics) many technology curricula now incorporate the ‘S’ and the ‘M’ into the design and development of solutions to problems (Winn, 2021). Most significantly of all, however, the wider context of society and the

workplace in which the school curriculum is being shaped have undergone some profound changes at a very high pace.

We are currently preparing students for jobs that don't yet exist, using technologies that haven't been invented, in order to solve problems, we don't even know are problems yet (Gunderson *et al.*, 2004, p. 13).

We are in a uniquely exciting time. We understand how to engage kids. We need to give them real-world challenges, have them work with other kids, and provide them with the right kind of adult support. Project-based learning is how people work in the real world. We need to let our kids create portfolios of joy (Dintersmith, 2018, p. 18).

In a survey by the National Association of Colleges and Employers (NACE, 2017), more than two-thirds of employers reported that they look for employees who demonstrate strong creative problem-solving, teamwork, and communication skills. For the United States to remain competitive in the 21st Century, our citizens must be equipped with creative problem-solving skills (Duyar *et al.*, 2019, p. 2).

Gunderson's rather apocalyptic view of the future has been in the literature, in similar forms, since the late 1950s (see Doxtater 2022). Robots have long been common on assembly lines. With the rise of the internet, some jobs such as travel agents, insurance brokers and bank tellers have certainly declined in numbers, and even highly skilled professions such as radiography are employing artificial intelligence (AI) to increase speed and accuracy of diagnosis. There is clearly a need to consider how the D&T curriculum and even aspects of

schooling itself will need to adapt in the face of the rapid changes taking place as society adapts to future challenges: a massive rise in on-line retail and the decimation of big high-street stores, ‘white-collar’ home working supplemented with video ‘office’ meetings, the development of new entrepreneurial ‘cottage industries’, and increased automation in manufacturing industries. If there really is a need to consider vocational usefulness as an aspect of curriculum development, how countries around the world respond to the new challenges and how different countries’ D&T curricula adapt to the new vocational context will be key for those that see the purpose of technology as being useful to the economy.

Publication 11 considers a range of different school curricula from a western ‘First World’ perspective but includes two less wealthy countries at the time of its publication (2013), Israel and South Africa. However, wealth is not a good yardstick to measure the quality of education. Drew (2011, p. 78) notes:

Frequently students in secondary school fail to learn math because their teachers simply do not understand the subject... [looking at math teachers with math degrees] The United States is ranked 41 out of 46 countries. The United States’ ranking is troubling. Students in Lithuania, Syria, Tunisia, Iran, Botswana, Jordan, Ghana, and the West Bank and Gaza are more likely to have a teacher with a math degree than are students in America!

Publication 11, p. 46 supports Drew’s view:

A US colleague recently lamented that there are many examples of good practice in US schools, but not enough, and they are not generally visible to those who make curriculum decisions. Technology education might disappear in the US as a result of a number of factors coming together:

- a debilitating shortage of technology teachers,
- lack of a cohesive approach to technology education,
- the learning area changing its name to Engineering,
- the STEM amalgamation being promoted,
- science looking to reinvent itself by teaching applications as well as content,
- science teachers having the opportunity to teach this area.

In many countries, technology is challenging a number of traditional characteristics of schooling - the decontextualization of knowledge, the primacy of the theoretical over the practical, and the organization of the curriculum along disciplinary lines. Some of the innovative trends which are obvious in a number of countries (**Publication 11** (p. 47)) demonstrate a movement from:

teacher as information giver	to	teacher as facilitator of learning
teacher controlled learning	to	teacher learner partnership
teacher centred learning	to	student centred learning
time age and group constraints	to	individualized learning
materials based organization	to	needs based activity
product centred	to	process centred
elective area of study	to	core subject
social irrelevance	to	socially contextualized

Publications 12 and **13** extend the international studies of technology education to a ‘developing world’ context through consideration of Bangladesh and of Malawi.

Publication 12 considers schools in the informal education system of Bangladesh, in particular that of the Underprivileged Children Education Programme (UCEP). The school provides a basic primary phase and a highly vocational secondary curriculum to 35,000 ‘working children’ every year. The children continue to work and earn while they attend school. UCEP schools operate 3 shifts per day, each of 3 hours duration. This allows a child to choose a shift of his/her convenience, in consultation with their parents (/guardians), to minimise the economic loss to the family for the children attending school. The schools offer the standard national curriculum taught over a shorter period, each year’s syllabus being completed in six months using the curriculum and textbooks prescribed by the National Curriculum and Textbook Board (NCTB), and incorporating basic elements of technical education too. In contrast to the national picture, the attendance rate at UCEP schools is almost 94% and the drop-out rate is very low (UCEP, 2022).

The UCEP schools became a trial site where the use of a mobile phone such as Nokia containing exemplar lessons on a micro-SD card was trialled. The combination of open and distance materials is demonstrated at <https://www.eiabd.com/>

The lack of relevance of the curriculum was a key finding in **Publication 13** in relation to both Bangladesh:

“Though we’re learning lots from secondary school, I’m not sure how much would be useful for our life, especially if we can’t carry on after secondary school. I think it could be better if we learn something which will help us to earn some money and make our life a bit easier. I don’t know what could be done for us. But we really need something which could make our lives comfortable and enjoyable”. [Student, Grade-VIII] (Shohel, 2010, p. 30) (**Publication 13**, p. 224).

and Malawi:

As a means of attaining relevance in the curriculum, the Policy and Investment Framework (PIF) (Ministry of Education and Vocational Training 2000) stipulated that:

....the primary and secondary school curriculum of the future should strive to impart essential skills and knowledge on a broad range of issues including new basic skills: critical thinking and analytical skills, civic and democratic values, computer skills, entrepreneurial skills, life skills and environmental education. (p. 12) (**Publication 13**, p. 227).

3.2 The contributions of the published works to the research on developing teachers of technology

Part 3.2a The contribution to teaching teachers of technology – the focus on pedagogy

Publications 7 and 8 have contributed extensively to a consideration of pedagogy in technology teaching. McGarr (2010) uses **Publication 7** when considering the former context for making subjects:

Speaking about the original focus of technology related subjects [...] pupils were required only to learn the knowledge, not to understand it, and to copy and practise the making skills” (p. 5). Banks (2008) notes that this was achieved by adopting a

pedagogy ‘not so very different to the ‘master-apprentice’ model of medieval guild (p. 151).

This point was picked up by another group of researchers from Ireland where the ‘show and copy’ methodology point was also made by Doyle *et al.* (2019b):

Internationally, technology, or design and technology education, was traditionally concerned with passing on to students traditional knowledge and skills, where students were required only to learn knowledge, not understand it, and to copy and practice making skills [...] Accordingly, practices have traditionally relied on the didactic transmission of knowledge, often being compared to the master apprentice model of the medieval guild (Banks, 2008), as the teacher was viewed as the subject expert and students as the passive recipients of knowledge.

In Doyle *et al.* (2019c, p. 475), the authors take this point further:

With rare exceptions D&T education internationally has evolved from a vocational background, which traditionally sought to meet culturally specific economic needs. Over the past 30 years, the philosophy of D&T in various cultures has begun to somewhat align, and with a shift towards a shared agenda for D&T internationally came new understandings of what is of importance to student learning. Whereas vocational subjects were primarily concerned with the transmission of specific content knowledge and development of specific skills (Banks 2008) [...], D&T education is broadly characterised by its potential to develop transferrable knowledge, skills, and attitudes. [...] In spite of the clear distinctions between the nature of vocational and D&T education, it is debated whether or not practices in D&T have shifted in alignment with international discourse and policy changes

(Banks & Barlex 2001) [...] From a pedagogical perspective, D&T is said to be characterised by a pedagogy where there is no ‘right answer’ but rather different responses to the same problem are valued, some more than others (Banks *et al.*, 2004 [**Publication 5**³⁶]).

In his PhD, Jones (2016, p. 32) points out that:

In 1995, the curriculum was revised, and the foundation subject renamed to Design and Technology [...]. This change included a focus on subject knowledge and the introduction of the product areas of resistant materials, systems and control, food and textiles. [...] The 1995 curriculum was easier to understand and introduced three types of assignments for pupils: designing and making products (DMA), focused practical tasks (FPT) and investigate, disassemble and evaluate products (IDEA). Although the creation of these types of tasks was seen as positive at the time [...], Banks (2008) argues that they were inappropriate for what the subject has become:

“It is clear that this traditional model of teaching is now inadequate as it teaches making skills without any underlying understanding, or development of other skills. Today we need teaching methods which match the broader aims that the subject has developed, and which will lead to the wider view of design and technology capability” (Banks, 2008, p. 174).

Banks (2008) discussed the problem in curriculum balance of Design and Make Assignments and Focused Tasks. Although open ended design assignments offer

³⁶ Banks, F., Barlex, D., Jarvinen, E-M, O'Sullivan, G., Owen-Jackson, G. and Rutland, M. (2004) 'DEPTH - Developing Professional Thinking for Technology Teachers: An International Study', *International Journal of Technology and Design Education*, Vol. 14 (2),

pupils choice and therefore motivation, the pupils may not have the knowledge to complete it successfully. However, a focused task or teacher decided project can allow pupils to successively build up their design knowledge and skills and/or technology knowledge and skills.

Publication 8 has also informed PhD studies. For example, Boodhoo (2018, p. 50):

Constructivism is a philosophical explanation suggesting that people construct their meaning of the world around them (and much of their learning) through a process of interpretation [...] (Banks, 2009). For example, a student always comes into class with prior knowledge, beliefs and experiences (Banks, 2009).

and Jones (2016, p. 33)

Evidence suggests that the rapid and unclear developments in the national curriculum have resulted in confusion among teachers. There is still unrest for D&T teachers with delays to the publication of GCSE D&T curriculum.

Comparative research has shown that the development of technology curricular across the world has been slow and implementation restricted, even when the new subject is ‘compulsory’ (Banks, 2009b, p. 374).

Part 3.2b The contribution to teaching teachers of technology – the focus on course methodology

Publication 9 has been used in a range of teacher education contexts. For example, Oluwale *et al.* (2013, p. 103) write in their discussion of vocational teacher education:

Since the objectives of TVET were to raise the standard of formal education and to provide professional skills, teacher trainees should be given a more adequate cultural foundation (mother tongue, modern languages, social sciences, etc). There should also be more emphasis on pedagogical skills. This is not to say that TVET can substitute for effective classroom teaching, particularly in catering for the wide range of abilities and backgrounds characteristic of classes today (Banks, 1996).

And in considering technology teachers' confidence in the classroom Jones *et al.* (2021, p. 118) point out:

As teachers' technology expertise has been identified as an issue, it is necessary to identify the types of knowledge which teachers do have. Theoretical models of teachers' knowledge have been developed since the mid-1980 s. Many researchers have classified the domains of teacher knowledge in order to understand teachers' pedagogy (Banks, 1996a; Banks *et al.*, 1999) [**Publication 9**].

But Jones *et al.* (2021, p. 131) also suggest:

This work does not evaluate the pedagogic methods used to deliver the projects or the effects of the "design" proportion of the tasks given to pupils. D&T is still a relatively new subject, and there is no universal solution as to how the subject should be taught (Banks 1996a, 1997, 2009) [**Publication 9**; Banks, 1997; **Publication 8**].

As discussed in Section 3.1b, the OUPGCE, of which Technology was one of the secondary subject lines, used on-line teaching using a modem and computer provided to the student

teachers as part of their materials (**Publication 10**). In 1994 computer conferencing was in its infancy and Google and Facebook were still in the future. However, on-line learning and how to make it successful was developing apace. Yang (2010) affirmed:

On-line teaching and learning will definitely fail without strong administrative support of programs, training, faculty and students. Moreover, Mayes and Banks (1998) concluded three factors combined to maintain quality and integrity of open learning courses: (1) common, structured course materials; (2) open assessment using a competency-based methodology; and (3) an extensive support and monitoring network. With strong support from administrators, faculty, and students will be more willing to teach and learn online (p. 366).

The lessons learnt from the development of the OUPGCE and the principles set out in **Publication 10** were picked up around the world. In Pakistan, for example, Munshi and Bhatti (2009) suggested:

Assessment is crucial for maintaining a quality in teacher education programs both Formative and summative assessment activities are necessary and must be undertaken at all levels. Mayes and Banks (1998), in setting out the quality assurance principles link quality assurance with consistency of materials development, assessment and approach (p. 14).

Part 3.2c The contribution to teaching teachers of technology – the international context

The development of Technology Education in an international context is set out in

Publication 11. The particular issues specific to the India sub-continent and sub-Saharan Africa are considered in **Publications 12** and **13**.

The rationale for including Technology as a school subject is of international concern. For example, Jakovljevic and Ankiewicz (2016, p. 226) point out:

One of the reasons stated for including technology in the curriculum is the possibility for personal development of higher cognitive skills, including creative thinking and problem solving (Banks & Williams 2013) [**Publication 11**].

Similarly, Doyle *et al.* (2019a, p. 760) conclude:

In considering teachers' beliefs about the goals and purposes of teaching technology, the educational context in which they are teaching emerges as a significant issue. Necessitated through the difficulties associated with achieving consensus regarding disciplinary goals, the importance of considering a teacher's educational context is supported by variances in technology education curricula internationally (Banks & Williams, 2013) [**Publication 11**].

Publication 11 has also had an impact on the consideration of a country's curriculum compared to those of other countries when the policy direction is being critiqued. Here Mosely (2019, p. 29) discusses the situation in Australia in her Masters dissertation:

The amalgamation of Design and Technology with Digital Technology or ICT in the Australian Curriculum in 2010 [...] was initially seen as a negative development with concern over how the coupling of subjects may create confusion about the nature of Design and Technology (Banks & Williams, 2013).

Technology teaching in a developing world context is important as it gives relevance to the curriculum. Low school attendance is often put down to poverty. That must be an element – extra pairs of hands are needed at crucial times such as harvest, and to look after younger siblings at home so that parents can work – but evidence from schools educating ‘working children’ suggest that this is not the only, nor is it the major, reason (Shohel & Banks, 2010). Probably more significant is that much of the school curriculum is considered irrelevant; the assessment regime is one that tests simple recall rather than processes that are useful; and in many state schools not only is the teaching often uninspiring but also, the pupils would say, too often the teachers use corporal punishment. To improve the quality of teaching and teacher education, it is necessary to take into account the realities of the current situation, the needs of pupils and the current context of pupils’ lives. These points are not confined to Bangladesh or other relatively poor countries although the issues are particularly marked there. In the UK too, for example, many 14-19 students question the relevance of the over-academic curriculum that is on offer and ‘vote with their feet’.

A study of the use of ICT for *teaching* in Bangladesh (Shohel & Kirkwood, 2012, p. 2) pointed out that ICT was not used much other than in the teaching of ICT itself:

In other words, rather than concentrating on ICT as a subject of study, technology should also be used more widely as a tool to enhance teaching and learning. This

supports experiences in other countries where projects have focused on teachers' professional development and with the local contexts and needs being addressed. In such circumstances, technologies can have a significant role to play in educational development in the Global South (Banks 2009, **Publication 12**), Banks, Moon & Wolfenden 2009).

In a study investigating the effectiveness of the use of mobile phones as a means of teacher education in the context of developing countries, Shohel and Power (2010) note:

Mobile technology could have a significant role to play in educational development in the Global South (Banks, 2011, Banks *et al.*, 2009, **Publication 12**, Banks, F., Moon, B. & Wolfenden, F.) Recently, research has begun to focus upon mobile learning, but the potential of mobile media players (for example, the iPod) is only recently being explored (p. 201).

Similarly, Hasan *et al.* (2015, p. 1297) in their consideration of new technologies as a means of supporting teacher education, write:

Mobile devices, in particular the mobile phone, are ubiquitous amongst the whole world population. Many countries have restructured their school curriculum to establish technology as a key learning area that is why they include the technological nature of society, enhancing the opportunities and possibilities for developing higher skills, including creative thinking and problem solving (Banks & Chikasanda, 2015) [**Publication 13**].

More generally Kelani and Gado (2018, p. 81) in a consideration of technology education as an element of science education in Benin set out a rationale for introducing the subject:

The World Conference on Science and Technology Education in Perth, Western Australia in July 2007, demonstrated that science and technology education is a universal requirement and contributes to three of the Education for All goals [...]. Accordingly, many countries have reformed their school curricula to establish technology as a key learning area for reasons that include the technological nature of society; technology being a driver of the global economy; technology enhancing the opportunities of the disadvantaged; and technology opening possibilities for developing higher cognitive skills, including creative thinking and problem solving (Banks & Chikasanda, 2015) [**Publication 13**].

Despite being on different continents the parallels between Bangladesh and Malawi, both commonwealth countries and influenced by a colonial past are marked. School drop-out rates are high and the need for a relevant practical curriculum is paramount. The UCEP schools featured in **Publication 12** make this case for practical and vocational relevance plain.

3.3 Conclusion

In Chapter 3, a focus on RQ2 and a consideration of the pedagogical knowledge of Technology in the classroom has shown how **Publications 7 and 8** formed a significant foundational base to the new works on pedagogy that have been published as recently as 2021. The exploration of contrasting forms and techniques of technology teacher education through different approaches and methodology (**Publications 9 and 10**), along with a consideration of new technologies for teacher professional development, are shown to have had a major international impact and made a significant contribution to new knowledge.

The impact of the **Publications 7 to 13** has been profound – worldwide and especially significantly in developing countries where new teachers and teacher improvement is most needed. The ‘R&D’ approaches applied to classrooms in Bangladesh has led to the development of novel approaches to teacher education and resources that have revolutionised day-to-day classroom practice.

Chapter 4 Theme 3: Developing Teachers of STEM

Research Question 3 (RQ3): In what was can the suggested elements of teacher professional knowledge support the development of teachers of STEM?

14. Banks, F. and McCormick, R. (2006) 'A Case Study of the Inter-Relationship between Science and Technology: England 1984-2004' in de Vries, M. J. and Custer, R (eds) *International Handbook of Technology Education*, Rotterdam, Netherlands: Sense Publishers, pp. 285-312, ISBN 90-77874-12-7.
15. Banks, F. (2013) 'Innovation Education through Science, Technology, Engineering, and Math (STEM) Subjects: The UK Experience' in Shavinina, L.V. (ed.) *The International Handbook on Innovation Education*, London: Routledge, pp. 557-569, ISBN 978-0-415-68221-3.
16. Banks, F. and Barlex, D. (2021) *Teaching STEM in the Secondary School: Helping teachers meet the challenge*, (Second edition) London: Routledge, ISBN 978-0-367-33045-3 (Chapters 1, 6, 9 and 10)

The STEM subjects (Science, Technology, Engineering and Mathematics) have for many years been acknowledged as embracing curriculum areas where the breadth of subject knowledge required for school teaching is particularly challenging (Stein *et al.*, 2007; Gill, 2017; Martin, 2017). In addressing RQ3 and the professional knowledge, particularly the broad subject knowledge required in STEM, it is appropriate specifically to explore teacher confidence in providing the 'T' and 'E' of technology and engineering in the STEM curriculum (Jones *et al.*, 2021). This has also been discussed through RQ2 in Chapter 3. However, the issue of the different and potentially conflicting personal subject constructs or 'professional identities' of the contributing STEM teachers (MacGregor, 2013) is key when STEM teachers need to 'look sideways' and collaborate for the benefit of their pupils (see the methods of collaboration discussed in Section 1.4). Across the three extensive publications cited for Chapter 4 is a close analysis of the relationship between Science and Technology. Politicians often see 'Science-and-Technology' as an epistemological unit, more or less the same thing, a single activity with areas inseparably linked which is the principal driver of the

modern economy (**Publication 16** p. 2). **Publication 16** points out the differences between these elements of STEM whereas **Publications 14 and 15** examine the similarities especially related to problem solving, and a focus on real-life exemplars outside the school context.

4.1 Literature review on developing teachers of STEM

Publication 14 is a case study of the development of science and technology education in schools in England. It provides a structure within which to consider the Specified, Enacted and Experienced curricula and to examine the changes that took place across the 20 years 1984 to 2004. In a similar way, the historical perspective informed a study of the development of the T in STEM within the curriculum in Sweden (Hallström *et al.*, 2009). There, elements from a vocational tradition, natural and social sciences, and a more recent techno-historical tradition, shape the subject at curriculum level and also at the enacted level in classrooms, where teachers bring practices both from their own teacher education and from the other subjects that they may teach, into their STEM lessons.

Almutairi *et al.* (2014, p. 56) explore the merits or otherwise of technology being closely tied to science. Technology is sometimes considered as merely ‘the appliance of science’ rather than there being emphasis instead on a clearly different epistemology between technology and science. This ‘demarcation’ versus links between these STEM subjects is explored as follows:

Contrary to the demarcationist view that stresses the differences between science and technology, Banks and McCormick (2006) [**Publication 14**] assert that there are some obvious similarities between science and technology in terms of three dimensions: both offer hands-on learning; both claim to support problem-solving; and both attempt to encourage students to be involved in authentic learning by

linking school activities to useful learning that students need in their daily life and the future needs of the work-place. Such a view has led some countries, such as the Netherlands, to consider technology and science as two mutually constitutive practices. In addition, such an understanding of the intimate relationship between science and technology influenced the developers of science and technology curricula.

Syafrill *et al.* (2021, p. 1) set out the case for the development of teachers across STEM but particularly those who have a background in science teaching:

The latest approach in the teaching-learning process called “Science, Technology, Engineering and Mathematics” (STEM) has become the most recent trend in this decade. STEM aims not only to process and produce talents with expertise in education but also to function as a catalyst for economic growth and national development. However, there are still impending issues associated with the usage of STEM in secondary school, one of which is related to the quality of teachers. [...]. The result showed that (i) an effective curriculum and (ii) increased motivation and teacher assistance in implementing STEM were the basis for improving teacher quality in STEM-based learning. STEM is useful in science learning, used in applying knowledge and skills for problem solving in everyday life. To improve teacher quality in the STEM-based teaching and learning process, teachers must master the conceptual model, design, implementation and evaluation of an integrated curriculum. Ongoing assistance to teachers to increase motivation in the STEM-based teaching and learning process also needs attention.

Almutairi *et al.* (2014) consider the relationship between science and technology (demarcation or technology as being merely ‘applied science’); this is tackled head on in **Publication 16**, Chapter 1, pp. 7-9.

The importance of problem-based learning through *authentic* learning contexts is the key point made in **Publication 15**, p. 559:

Although some teachers might have balked at teaching students to become ‘merely factory fodder’, they were more than content to adopt teaching techniques that promoted critical thinking and teach through links to real life and a practical purpose. Two examples illustrate this change in emphasis in schools through TVEI [Technical and Vocational Education Initiative] funding and the promotion of innovation and enterprise. [...] In Powys in mid-Wales, for instance, students were asked to work in teams to design and make novel garden furniture such as plant boxes and picnic tables which would be attractive for sale both to private users and robust enough for public use in parks. The students proposed a range of possible designs and negotiated what was wanted with potential customers and local government officials and, as a small collective, manufactured, advertised, and sold their new products.

Kurup and Xia (2022, p. 3) support this idea:

While STEM provides an umbrella under which these more traditional approaches to curriculum fit, the blending and emphasis of these disciplines, across a range of authentic contexts, allows students to transfer and apply knowledge tailored to specific problems. As a result, students’ growing STEM

knowledge base forms new connections and ways of working that are adapted and sometimes novel to those they might meet if studying the separate disciplines.

Linked to the idea of STEM dealing with authentic real-life problems is the teaching and learning of problem-solving strategies. Barak (2020, p. 249) sets out what he calls ‘Systematic Inventive Thinking’:

Systematic Inventive Thinking (SIT) is a method of finding solutions to problems by making systematic alterations or manipulations with a system’s components and attributes, rather than searching randomly for ideas using methods such as brainstorming. [...]

Among the principles or tools learned in the SIT course are:

- *Unification*: solving a problem by assigning a new use or role to an existing object
- *Multiplication*: solving a problem by introducing a slightly modified copy of an existing object into the current system
- *Division*: solving a problem by dividing or cutting an object or subsystem and reorganizing its parts
- *Change relationships between variables (attribute dependency)*: solving a problem by adding, removing, or altering relationships between variables
- *Removal*: solving a problem by removing an object (with its main function) from the system
- *Inversion*: solving a problem by inverting the structure or functions of components in a system.

This and other approaches to problem solving are discussed in **Publication 16**, Chapter 6 and in **Publication 8**³⁷ (p. 379).

Jawad *et al.* (2021, p. 173) in their work in Iraq underline the need for authenticity and problem-solving techniques across STEM including the ‘M’:

The mathematics in textbooks that students learn is far from what students need in terms of mathematical knowledge in other subjects such as science; because mathematics is the subject of the mind and thinking, the development of thinking skills, especially innovative thinking, is necessary to study mathematics, despite this, many studies have shown that there is a decline in the levels of innovative thinking among students, and accordingly, we need what helps the development of this thinking since the STEM approach is primarily based on research, investigation, experiment, innovation, it will surely help students develop their innovative thinking skills.

The ‘T’ and ‘E’ in STEM as taught in schools can be brought together when considering the place of computing. This is true of science and mathematics too but ‘Tech’ in common speech often means computers and smart phones, and their use in STEM and designing electronic artefacts comes together in **Publication 16**, Chapter 9. There it is made clear (p. 188) that:

Before we consider for what we might use computers – smartphones, ipads, laptops and notebooks – in our teaching, we need to pause and think through our beliefs about the relationship between the pupil and the teacher. Who is in control of the

³⁷ Banks, F. (2009) ‘Research on Teaching and Learning in Technology Education’ in Jones, A. and de Vries, M. (eds.) *International Handbook of Research and Development in Technology Education*, Sense Publishers: Rotterdam Netherlands, pp. 373-390.

learning process? What are our attitudes to ‘hands-on’ skills and mathematical processes rather than computer simulation, calculator use and computer aided activities? Can augmented reality (AR) or virtual reality (VR) blur the distinction between ‘hands on’ and ‘computer simulation’? What do we think of the use of smartphones being available during lessons?

The use of smartphones, ipods and other new technologies in schools, especially as a means of supporting teachers’ pedagogy, has been discussed above in Section 3.2c and in Shohel and Banks (2010) and Shohel and Banks (2012). Credit-card sized project computers such as the Raspberry Pi and the BBC micro:bit with the ability to attach peripheral devices have also enabled sophisticated pupil projects which can solve authentic problems. **Publication 16**, Chapter 9 (p. 205):

The launch of these small and cheap computers combined with the new push for Computer Science in schools around the world has created enormous interest. The impetus for the development was to see cheap, accessible computers back in the hands of young people everywhere. With free open-source software available, a new wave of computer programmers may start to enter higher education. Free software and training in the use of Python and computer languages are available from the Raspberry Pi Foundation and from Micro:bit.

Jolles (2021) notes the possible use of a Raspberry Pi in the biological sciences:

By far the most popular single-board computer is the Raspberry Pi, with over 37 million units sold since 2012, a huge on-line community (over 300k users on [raspberrypi.org/forums](https://www.raspberrypi.org/forums)), and educators using it to teach computing to millions of young people around the world (Raspberry Pi Foundation, 2020). Built on open-

source principles and driven by the non-profit incentive to increase global access to computing and digital making, this low-cost computer brings together external hardware, sensor and controller interfaces, with user- friendly programming capabilities, high connectivity and desk-top functionality [...] It is also the most widely used low-cost computer by the biological research community and is employed in a broad range of projects across diverse topics and research fields.

As we discussed when considering the use of the mobile phone use as a device for demonstrating teaching strategies using a micro-SD card, for pupils too a computer many times more powerful than the one that enabled men to walk on the moon is now available and in the pocket of most secondary school children in the West, and as I witnessed, in India too.

But **Publication 16**, Chapter 9 (p. 209) recognises that there are practical problems:

The fact that France, the state of Victoria and many schools around the world have banned the use of mobile phones in schools is indicative about worries that many parents have that a ‘library in the hand’ and a powerful personal ‘computer in the pocket’ that can be used for STEM and other learning is overshadowed by the possible negative aspects of personal phones. While no one would belittle the harm done by sites encouraging young people to question their body-image or offer advice on self-harm and even questioning their personal worth, how and where pupils should be taught to react to such information needs to be addressed. It is a fact that in any mainstream high school class in 2020 at *least* 60% of the pupils will have their own phone, and that cuts across all income and social groups, and ownership can only increase as the power of phones soars and competition forces costs down.

The teachers at Ysgol Uwchradd Caergybi in Holyhead, Wales are clear that pupils need to be educated in the use of their smartphone – from how to keep safe on social media through to using it for more than the latest on-line gaming craze – and that using phones in class appropriately in the classroom quickly becomes normalised. The school moved away from a phone ban as both parents and pupils complained that confiscating phones caused domestic difficulties as to where and when pupils were to be picked up; and any changes of plans are now done by phone. The school staff are adamant that now that the ‘confrontation has gone’ a phone can readily be used in a lesson when needed or put away when requested.

Support for the view that the mobile phone is a useful tool comes from Webb (2013, p. 180):

As the number of students with cell phones has steadily increased over the past decade, these technological advances have caused trepidation among educators over behavioral issues, from off-task activities to cheating. On the other hand, mobile learning, as well as some tools to use with cell phones, are easy to set up, easy to use, and easy to integrate into existing instructional strategies in the classroom. Instead of banning devices, educators can counter the negative issues by embracing cell phones as a means to engage students in lessons.

Despite their title ‘Cell Phones in the Classroom: Are we Dialling up Disaster?’ Engel and Green (2011, p. 45) are advocates for the school use of mobile devices as long as guidelines are set such as:

- *Student Education and Understanding:* Students need to have a clear understanding of what is expected of them when they are using the devices. Students need to understand the policies associated with using the devices.

Students should also be made aware of potential issues related to using the devices (i.e., cyber-bullying, privacy issues).

- *Parent Involvement:* It is critical to have parent involvement. The more information parents have about who, when, where, and why the devices will be used the more likely they will be in support of their use.

Schools often engage with STEM projects as off-timetable clubs and through different inter-school competitions. Although these may be very worthwhile, the fact that such activity is not embedded in the curriculum – for both boys and girls equally – needs to be considered. There is a need for teachers to ‘Look Sideways’ at what is happening in the other STEM subjects and to engage colleagues in dialogue about how they can work in a coordinated approach, a collaborative approach or through the integration of the STEM subjects (see Section 1.2).

Publication 16, Chapter 10 addresses the need to create an environment for sustaining STEM. Class teachers and school leaders working together need to address the physical environment, the pupils’ learning environment, and the teachers’ professional environment.

The pupils’ learning environment is perhaps the most important; STEM needs to be attractive to all. However, as pointed out in **Publication 16** (p. 221):

When teachers are observed, they are sometimes surprised to discover that the girls are more likely to be praised for being well-behaved while boys are more likely to be praised for their ideas and understanding. A disruptive girl may be admonished more than a boy who exhibits similar behaviour. Quiet boys are often overlooked.

Consequently, girls and boys learn the ‘rules of the classroom’ – girls do not take risks and boys ‘opt out’ if they do not ‘get it’ easily.

Gender issues in relation to STEM are of international concern but focusing just on the simple notion of family assumptions about ‘appropriate subjects’ for girls, or the different toys that girls and boys are traditionally given, is seen to be over simplistic. Barth *et al.* (2022) suggest that peer assumptions may be a more significant factor influencing adolescent girls:

Previous research on the impact of gender stereotypes on female adolescents’ feeling of belonging to peer groups has focused on STEM classrooms and activities. This study expands this research and examines if perceptions of group-held gender stereotypes are related to adolescent girls’ feelings of belonging to other social groups. Girls (N = 110) in advanced science and math classes (primarily 9th grade) completed an on-line survey that included questions about three groups: their science class, their close friendship group, and another peer group of their choosing, classified as their most important group (MIG). Questions about the groups included belonging, their perceptions of the group’s gender stereotypical beliefs, and additional social contextual variables that are associated with belonging for girls—presence of close friends, presence of a best friend, and the number of girls relative to boys.

Results indicated that girls perceived the different groups to hold different levels of gender stereotypical beliefs. Perceptions that a group held more traditional stereotypical beliefs was negatively correlated with belonging to each of the three groups. Regression analyses indicated the number of friends and perceptions of more traditional stereotypes predicted belonging to MIGs and science classes.

Findings suggest that gender stereotypes may be an important factor in how adolescent girls perceive their belonging in many adolescent groups (Barth *et al.* January 2022, on-line).

A number of initiatives have addressed the idea that role models will encourage more girls to engage in STEM subjects. **Publication 16**, Chapter 1 p. 1 sets the scene:

The other day I repeated something I had done five years ago. I asked some upper-primary school and lower secondary school pupils to draw a picture of a ‘Scientist’ and a picture of an ‘Engineer’. Of course, not many of them had ever met a scientist and so, just as five years ago, some drew the cliché often seen in films – white, male, middle aged, balding or ‘mad’-haired and white-coated – bit like Doc in *Back to the Future* – with Dr Frankenstein wild eyes, and a bubbling conical flask in their hand as a modern-day Dr Jekyll. But this time there were some significant differences. Some pupils, both boys and girls, drew their scientist as female, dressed more as an ‘explorer’ rather than wearing a white coat, and with a sunhat, magnifying glass, notebook and pencil. And the engineer? Well, like before, all male, with a hard hat and carrying a larger-than-life spanner. Whilst accepting that the very act of asking for pictures to be drawn might have led them to offer me a caricature of how scientist and engineers are commonly represented in the media, I was intrigued that although it seems the stereotype of a scientist is changing, engineering is generally still seen as ‘male’ despite the impetus over the years to broaden the appeal of both engineering and the physical sciences.

Breda *et al.* (2022) confirm the positive trend towards weakening stereotypical views about women and success in studying STEM:

We show in a large-scale field experiment that a brief exposure to female role models working in scientific fields affects high school students' perceptions and choice of undergraduate major. While the classroom interventions generally reduce the prevalence of stereotypical views on jobs in science and gender differences in abilities, the effects on educational choices are concentrated among high-achieving girls in Grade 12. They are more likely to enrol in selective and male-dominated STEM programs in college. The most effective role model interventions are those that improved students' perceptions of STEM careers without overemphasizing women's underrepresentation in science.

4.2 The contribution to the research on developing teachers of STEM

The value of interrogating a curriculum in terms of the Specified, Enacted and Experienced curriculum, used as part of the criteria to select the publications (see Table 1), has been confirmed by a number of studies. Bourn and Brown (2011, p. 15), for example, report:

However, a number of studies offer some insight, both into educators' responses to the range of initiatives and agendas promoting global education and young people's awareness of learning opportunities offered to them. This distinction can be described as between the enacted curriculum (the way in which teachers put the curriculum into practice) and the experienced curriculum (as it is encountered by students) [...] (Banks & McCormick, 2005 [**Publication 14** and **Publication 12**]). This distinction is important, because what learners learn is distinct from what teachers teach [...] The enacted curriculum is again distinct from the curriculum as laid out in policy documents (the specified curriculum) indeed there is often a large gap between the two⁶. This is certainly the case in relation to global education, as schools develop their own global curricula independently [...].

Hallström *et al.* (2014, p. 136) detail the Swedish curriculum using the same analytical framework:

[...] a vocational tradition, natural and social sciences as well as a more recent techno-historical tradition shape the subject at the specific curriculum level as well as at the enacted level in classrooms, where teachers also bring practices from their own teacher education and the other subjects, they teach into technology education (Banks & McCormick, 2006 [**Publication 14**]). As a result, Technology is still not a firmly established subject and has a low status.

More broadly, the structural links between science and technology established in **Publication 14** have attracted wide international interest, as illustrated for example by Nordstrom (2013, p. 378)

There is also a strong tradition of using technology education to provide examples and practice for school science. It has been prominent in [...] England (Banks & McCormick (2006, p. 285 [**Publication 14**])).

In the following some cite the first edition of **Publication 16** (2014) and some the second edition (2021).

Publication 16 explores the idea of ‘minds on’ as well as ‘hands on’ learning in STEM. This emphasis on technological literacy is picked up by Niiranen (2019), who writes (p. 83):

Technology education has been developed to help students with technology by providing them the tools and skills they need to understand and utilize it.

Technology education makes a unique contribution to the development of all

young people by providing them a wide range of knowledge and skills, i.e. technological literacy to participate in the rapidly changing technologies (Banks & Barlex, 2014 [**Publication 16**]).

Similarly, this wider contribution of STEM is recognised by Razali (2021, p. 386):

The skills developed as a result of STEM learning encompass the entire 21st-century skills of creativity, critical thinking, collaboration, and innovation based on STEM knowledge (Banks & Barlex, 2014).

On authentic contexts for problem-solving in STEM, Arshad *et al.* (2021, p. 160) draw on **Publication 16** as they write:

Engineering Design enables students to enhance their cognitive abilities, namely problem solving, creative thinking, formulating solutions, and decision-making skills. As a result, students would be able to learn mathematical or science concepts through a more authentic process by relating them to real-life situations (Banks & Barlex, 2021 [**Publication 16**]).

Other researchers too have been persuaded by the argument that real-world contexts should be integral to STEM teaching and learning, for example Kang (2019, p. 3):

In a number of reviews on integrated STEM programs, researchers found that integrated STEM programs commonly utilize real-world complex problems as instructional contexts in which students apply knowledge and practices from multiple disciplines (Banks & Barlex, 2021) [**Publication 16**].

Delahunty and Kimbell (2021, pp. 745, 746 and 754) recognise many fundamental points made in **Publication 16** such as that:

Each of the sub-disciplines of STEM have associated characteristic knowledge types, such as the propositional knowledge of science and the procedural or pragmatic knowledge associated with technology (Banks & Barlex, 2014). [...]

STEM education is typically characterised by project-based learning environments where students are tasked with solving complex problems in collaboration (Banks & Barlex, 2014). The notion of learning within STEM cannot be entirely captured by a lens of information processing or social constructivism alone and requires a metaphor that synthesises both. For example, while the collaboration we as educators envisage students' engaging with in solving a design task frames [the] learning in the social constructivist sense, there will undoubtedly be times when students, either directed by the teacher within a scaffolded pedagogical strategy or self-directed, will need to acquire new knowledge or skills. [...]

Critical to the theory is that it is learner-centred and learner-determined, therefore building on work such as the importance of autonomous motivation for learning [...]. It is an approach premised on the development of capability and acknowledging the importance of knowledge utility and creative problem solving (Banks & Barlex, 2014 [**Publication 16**]).

The principal message of **Publication 16** is that colleagues teaching a STEM subject need to 'Look Sideways' at what is being taught in the other STEM subjects so that they can build on that for the benefit of their pupils. This is fully recognised by Aydogan Yenmez *et al.* (2021, p. 252):

Banks & Barlex (2014) stated that it is important to teach science and technology in a wider context with mathematics and engineering, because when

disciplines are taught discrete students are not able to recognize the connection between different contents and cannot develop a systematic comprehensive view of the world around them.

4.3 Conclusion

Publications 14, 15 and 16 address RQ3 as they build on the key ideas that the contributory subjects of STEM have a number of similarities in the common threads such as problem-solving, discovery approaches and direct applicability to everyday life. These are aspects of teacher professional knowledge that all teachers of STEM, whatever their ‘home subject,’ need to know. **Publication 16** makes the fundamental point that teachers can benefit their pupils if they share their professional knowledge and ‘look sideways’ to take advantage of teaching and learning in related STEM subjects.

But if technology is merely seen as ‘applied science’, then technology educators miss the point about the subject for which they are responsible. Technology is founded in human need to change the environment, science in understanding the whys and wherefores of the world around, while mathematics is a service to both, and an exciting and intriguing aspect of human endeavour in its own right. The ‘*know-why*’ of science is a fundamentally different goal from the ‘*know-how*’ of technology. Science and mathematics knowledge and understanding will often contribute to project work in schools, but it is necessary to keep in mind the often-limited extent of such knowledge which is actually required when designing and making products. The contribution of science needs to be set against the other dominant factors such as *sustainability*, *aesthetics* and *appropriateness*.

Publication 15 in its consideration of the contribution of STEM to innovation education shows that no one subject is more important than any other in STEM. Indeed, in the enterprise of creating for the ‘real world’, sometimes science follows technology and mathematics is often key to help improve our understanding of both.

The outcomes of STEM subjects are steeped in the culture and social values of the society which uses them. It is these often-neglected value-laden aspects of teaching and learning across all STEM subjects highlights the distinctive role for engineering and technology in enhancing human behaviour. This is of fundamental importance. Consequently, I regard **Publication 16** and its contribution to addressing RQ3 as the culmination of decades of research into Teacher Professional Knowledge and as a major development outcome in ‘Helping Teachers Meet the Challenge’.

Chapter 5 Conclusion – Contribution to new knowledge and a summary of reception and impact in the field.

5.1 Contribution to new knowledge

Table 1 on page 36 set out the rationale for the selection of the publications as they contribute to an exploration of the Research Questions 1 – 3 through a series of evaluation studies that adopted a research and development (R&D) methodology.

Research Question 1 (RQ1): What are the elements of teacher professional knowledge and what is their inter-relationship? Consideration of this question has shown the key concepts that the thesis contributes to new knowledge are:

- The discovery, verification and exploitation of a new way to conceptualise the common aspects of teacher professional knowledge across subject domains.
- The development of a graphical tool to explore teacher professional knowledge, and the discovery that teachers can use it to investigate and share professional understandings in their own contexts, demonstrating its applicability across education regimes internationally.

Research Question 2 (RQ2): In what ways can the suggested elements of teacher professional knowledge support the development of teachers of Technology? Consideration of this question has shown the key concept that the thesis contributes to new knowledge is:

- The development of new open and distance learning techniques for the professional development of Technology teachers through the use of new technologies in both the UK and Internationally

Research Question 3 (RQ3): In what ways can the suggested elements of teacher professional knowledge support the development of teachers of STEM? Consideration of this question has shown the key concept that the thesis contributes to new knowledge is:

- The exploration and dissemination of novel in-school strategies that can be used to develop and support secondary teachers of STEM, wherever they are located, by enabling them to collaborate by ‘looking sideways’ at the work that is done by colleagues in the contributory STEM subjects; and ways in which those developments can be supported by school leaders.

5.2 Impact in the field

The impact of all the publications has been at an international level. My research and developments outputs have been taken up and extended in PhD and EdD theses in Australia, Canada, Middle East, New Zealand and the United Kingdom.

My publications related to technology and STEM education are cited in journals published in Asia , Australia, and Europe by researchers from around the world including Australia, Belgium, Indonesia, Ireland, Italy, Japan, Korea, Malaysia, Singapore, South Africa, Spain, Sweden, and Turkey.

The total citations are shown below for each theme and for each publication. Also, the ‘h index’ and impact score for the journals are given where appropriate.

Theme 1: Teacher Professional Knowledge – RQ1

- The publications in the area of teacher professional knowledge have, taken together, been cited 232 times.

Theme 2: Developing Teachers of Technology – RQ2

- The publication in the area of developing teachers of technology have, taken together, been cited 94 times.

Theme 3: Developing Teachers of STEM – RQ3

- The publications in the area of developing teachers of STEM have been cited 153 times

Publications on Teacher Professional Knowledge

1. Banks, F. R.J. (1988) *A Preliminary Evaluation of the Two-Year PGCE and Diploma in Physics*. Swansea: University College of Swansea, Education Department Research Monograph No. 1.
2. Banks, F.R.J. (1996) ‘Developing professional knowledge during initial design and technology teacher education’, *Journal of Design and Technology Education*, **1** (2) 175-178, ISSN 1360-1431. **Cited by 17.**

The Journal of Design and Technology Education later became the International Journal of Technology and Design Education. It is the premier journal for design and technology education in the UK.

3. Banks, F. (1997) ‘Assessing Technology Teacher Professional Knowledge’ *Proceedings of PATT-8 Conference*, Scheveningen, Netherlands, April 1997, pp. 240-251. **Cited by 10.**

The PATT conference is the premiere research conference in Technology Education. It is organised by Delft University, Netherlands.

4. Banks, F., Leach, J. and Moon, B (2005) ‘Extract from “New understandings of teachers’ pedagogic knowledge”’, *Curriculum Journal*, **16** (3) 331-340, ISSN 0958-5176. **Cited by 104** (Original OU Chapter cited by 227) (33%)

The Curriculum Journal is published by Taylor & Francis and has an h-index of 18, impact score 1.00.

5. Banks, F., Barlex, D., Jarvinen, E-M, O'Sullivan, G., Owen-Jackson, G. and Rutland, M. (2004) 'DEPTH - Developing Professional Thinking for Technology Teachers: An International Study', *International Journal of Technology and Design Education*, **14** (2) 141-157, Holland: Kluwer Academic Publishers., ISSN 0957-7572. **Cited by 73** (20%)

6. Banks, F. (2008) 'Learning in DEPTH: Developing a Graphical Tool for Professional Thinking for Technology Teachers', *International Journal of Technology and Design*, Springer, **18** (3) 221-229. ISSN 0957-7572. (Guest Editor for this Special Edition of DEPTH papers). **Cited by 28.**

The International Journal of Technology and Design Education is now published by Springer in the Netherlands. It has an h-index 31 and impact score 2.03.

Publications on Developing Teachers of Technology

7. Banks, F. (2008) 'Teaching Design and Technology' in Owen-Jackson, G. (ed.) *Learning to Teach Design and Technology in the Secondary School*, (2nd Edition), London: Routledge/Falmer, pp. 174-193, ISBN: 0-415-46493-5. **Cited by 9.**

Intended as 'A Companion to School Experience'. The 'Learning to Teach Subjects in the Secondary School' is a series of 14 edited books by Routledge, only 3 of which have, as here, been published as a second edition.

8. Banks, F. (2009) 'Research on Teaching and Learning in Technology Education' in Jones, A. and de Vries, M. (eds.) *International Handbook of Research and Development in Technology Education*, Rotterdam, Netherlands: Sense Publishers, pp. 373-390, ISBN:978-90-8790-877-5. **Cited by 20.**

The 'International Handbook of Research and Development in Technology Education' was the first such publication in Technology education. It is part of the International Technology Education Series published by Sense, Rotterdam.

9. Banks, F.R.J. (1996) 'Approaches and models in technology teacher education: an overview', *Journal of Design and Technology Education*, **1** (3) 197-211, ISSN 1360-1431. **Cited by 19.**

The Journal of Design and Technology Education later became the International Journal of Technology and Design Education. It is the premier journal for design and technology in the UK.

10. Banks, F. and Shelton Mayes, A. (1998) 'High quality and new standards: an open learning contribution to the improvement of pre-service teacher education', *Paper at AERA*, San Diego, USA. April 1998. **Cited by 11 (50%)**

The American Educational Research Association (AERA) Conference is the premier education conference in the USA.

11. Banks, F. and Williams, P. J. (2013) 'International perspectives on technology education' in Owen-Jackson, G. (ed.) *Debates in Design and Technology Education*, London: Routledge, pp. 31-48., ISBN 978-0-415-68904-5. **Cited by 12 (75%)**

12. Banks, F. (2011) 'Technological Literacy in a Developing World Context: The Case of Bangladesh' in M. de Vries (ed.) *Positioning Technology Education in the Curriculum*, Rotterdam, Netherlands: Sense Publishers, pp. 219-226, ISBN: 978-94-6091-674-8. **Cited by 17.**

This publication is part of the International Technology Education Series published by Sense, Rotterdam.

13. Banks, F. and Chikasanda, V. (2015) 'Technology Education and Developing Countries' in Williams P.J., Jones, A. and Buntting, C. (eds.) *The Future of Technology Education*, Singapore: Springer, pp. 217-238, ISBN 978-981-287-169-5. **Cited by 6** (50% - author of Bangladesh case study)

This publication is part of the Contemporary Issues in Technology Education published by Springer, Heidelberg.

Publications on Developing Teachers of STEM

14. Banks, F. and McCormick, R. (2006) 'A Case Study of the Relationship between Science and Technology: England 1984-2004' in de Vries, M. J. and. Custer, R (eds.) *International Handbook of Technology Education*, Rotterdam, Netherlands: Sense Publishers, pp. 285-312, ISBN 90-77874-12-7. **Cited by 21** (50%)

This publication is part of the International Technology Education Series published by Sense, Rotterdam.

15. Banks, F. (2013) 'Innovation Education through Science, Technology, Engineering, and Math (STEM) Subjects: The UK Experience' in Shavinina, L.V. (ed.) *The International Handbook on Innovation Education*, London: Routledge, pp. 557-569, ISBN 978-0-415-68221-3.

This chapter explores both. This publication is part of the Routledge International Handbook Series, Routledge, New York.

16. Banks, F. and Barlex, D. (2021) *Teaching STEM in the Secondary School: Helping teachers meet the challenge*, (Second edition) London: Routledge, 291 pp., ISBN 978-0-367-33045-3

Author of Chapters: 1, 2, 6, 9 and 10 in both first and second editions. (Chapters 1, 6, 9 and 10 from the second edition are used in the portfolio. Chapter 2 builds directly on **Publications 4 and 14** and therefore has been omitted) (Edition 1 published in 2014) **Cited by 132 (50%)**

References

- Almutairi, A., Everatt, J., Snape, P. and Fox-Turnbull, W. (2014) 'Exploring the Relationship between Science and Technology in the Curriculum' *Australasian Journal of Technology Education*. Available at: <https://www.ajte.org/index.php/AJTE/article/view/16> (Accessed: 8 August 2022)
- Anglim, B.J. (2021) 'Design and Technology and STEM: Teachers' Perception of Gender' Unpublished *EdD Thesis*, Sheffield: Sheffield University.
- Arshad, A.M. L. Halim, L. and Nasri, N.M. (2021) 'Impact of integrating science and engineering teaching approach on students' achievement: a meta-analysis' *Journal Pendidikan IPA Indonesia* 159-170 DOI: 10.15294/jpii.v10i2.29839
- Aydogan Yenmez, A., Gökce, S., Aydede, M.N. and Çelik, T. (2021). Investigation of pre-service teachers' awareness of STEM and STEM teaching intention. *International Online Journal of Education and Teaching (IOJET)*, **8** (1) 250-260.
- Banks, F. (1986) *Astronomy: A Guide for Teachers*, Llandrindod: Powys County Council.
- Banks, F. (1989) *Ideas from TECHNIQUEST for Key Stage 2*, Cardiff: Institute of Physics/TECHNIQUEST.
- Banks, F. *et al.* (1990) *Design and Technology Non-Statutory Guidance for Teachers*, Cardiff: Curriculum Council for Wales.
- Banks, F., Parkinson, J. and Woodward, C. (1991) *Assessment in Science*, Swansea: University of College of Wales.
- Banks, F. (ed.) (1992) *Experimental Investigations for Post-16 Physics*, Swansea: University of Wales.
- Banks, F. (ed.) (1994) *Teaching Technology*, London: Routledge.
- Banks, F., Breckon, A., Bassett, S., Green, N., Hopkinson, M., Huntingford, L., Jepson, M., Mittell, I. and Stables, K. (1995) 'Minimum competences for students to teach Design and Technology in Secondary Schools', *Research Paper Number 4. Design and Technology Association*, Wellesbourne, UK: DATA.
- Banks, F., Leach, J., and Moon, B. (1996) 'Knowledge, school knowledge and pedagogy; reconceptualising curricula and defining a research agenda'. *Paper at ECER 96 Conference*, Seville, Spain. September 1996.
- Banks, F. (1997). 'What prior experiences are perceived as useful to students following an ITT design and technology course?' *Journal of Design and Technology Education*, **2** (3) 230–235
- Banks, F., Hobbs, S., and Moon, B (1997) *Open and Distance Education, New Technologies and the Development of Teacher Education in Europe: A Handbook*, Milton Keynes: The Open University (and translations in German, French and Spanish)

Banks, F. (2001) 'CPD for ICT in D&T: using LSP!' *Proc. of PATT-11 conference*, Haarlem, the Netherlands, March 2001.

Banks, F. and Barlex, D. (2001) 'No one forgets a good teacher! - What do 'Good' Technology Teachers Know?', *European Education*, **33** (4) 17–27.

Banks, F. (2003) 'TeachandLearn.net: Using new technology to support D&T teachers', *Proc. of PATT-13 Conference*, Glasgow, UK, June 2003, 145-149.

Banks, F. (2006a) 'Technology, Design and Society' versus 'Science, Technology and Society (STS): Learning some lessons' in Dakers, J. R. (ed.) *Defining Technological Literacy: Towards an Epistemological Framework*, New York: Palgrave, pp. 97-217

Banks, F. (2006b) 'Technology Teacher Education in the UK', in Williams, P. J. (ed.) (2006) *International Technology Teacher Education*, 55th Council on Technology Teacher Education Yearbook, CTTE, Glencoe, USA: McGraw Hill, pp. 215-239.

Banks, F., Bird, M., Deane, M., Hedges, C., Leach, J. and Moon, B. (2007) *Costing Open and Distance Teacher Education: Case Study Examples from Sub-Saharan Africa*, Washington: The International Banks for Reconstruction and development/The World Bank Institute.

Banks, F. (2009) 'Competency Based training in the UK' in Jones, A. and de Vries, M. (eds.) *International Handbook of Research and Development in Technology Education*, Rotterdam, Netherlands: Sense Publishers, pp. 555-568.

Banks, F., Moon, B. and Wolfenden, F. (2009). 'New modes of communication technologies and the reform of open and distance learning programmes: A response to the global crisis in teacher education and training'. In: *23rd ICDE World Conference on Open and Distance Learning*, 8-10 June 2009, Maastricht, The Netherlands.

Banks, F. (2011) *Inaugural Lecture* – 'Teachers Taught, Lessons Learned', Milton Keynes.

Banks, F. (2014) 'On-line teacher professional development – The TeachandLearn.net experience' in Mathew, R., Geeta, T., Chennai, S. (eds.) *E-Learning in Teacher Education: Experience and Emerging Issues*, Delhi, India: Department of Education (CIE), University of Delhi, pp. 46-65.

Barak M. (2020) 'Teaching Problem-Solving in the Digital Era'. In: Williams P., Barlex D. (eds) *Pedagogy for Technology Education in Secondary Schools. Contemporary Issues in Technology Education*. Singapore: Springer.
https://doi-org.libezproxy.open.ac.uk/10.1007/978-3-030-41548-8_13

Barlex, D. (2012) 'Engaging design & technology trainee teachers with the nature of technology – a case study' *Paper at PATT 26 Conference*, Stockholm, Sweden. June 2012

Barth, J.M., Masters, S.L. and Parker, J.G. (2022) 'Gender stereotypes and belonging across high school girls' social groups: beyond the STEM classroom'. *Soc Psychol Educ*.
<https://doi.org/10.1007/s11218-021-09683-2>

Biesta, G. (2021) 'Mixing Methods in Educational Research' in Coe, R. Waring, M., Hedges, L.V. and Day Ashley, L. (eds.) *Research Methods & Methodologies in Education: Third Edition*, London: Sage publishers.

Boodhoo, C. (2018) 'Assessment for learning in Design and Technology: An ethnographic study in Mauritius state secondary schools' *Unpublished PhD Thesis*, Waikato: The University of Waikato, New Zealand.

Bourn, D. and Brown, K. (2011) 'Young People and International Development' *Research Paper No.2 Development Education Research Centre*, London: Institute of Education.

Breda, T., Grenet, J., Monnet, M. and van Effenterre, C. (2021) 'Do Female Role Models Reduce the Gender Gap in Science? Evidence from French High Schools.' Available at: <https://halshs.archives-ouvertes.fr/halshs-01713068v5> (Accessed: 30 January 2022)

British Educational Research Association [BERA] (2018) *Ethical Guidelines for Educational Research*, fourth edition, London: BERA.

Bruner, J. S. (1986) *Actual Minds, Possible Worlds*, London: Harvard University Press.

Bruner, J. S. (1996) *The Culture of Education*, Cambridge, Mass.: Harvard University Press

Cattaneo, A.A.P., Antonietti, C. Rauseo, M. (2022) 'How digitalised are vocational teachers? Assessing digital competence in vocational education and looking at its underlying factors', *Computers & Education*, **176**.

CCA (2022) *Council for the Curriculum, Examinations and Assessment*. Available at: <https://ccea.org.uk/> (Accessed: 22 January 2022)

Chevellard, Y. (1991) *La Transposition Didactique: Du savoir savant au savoir enseigné*, Paris: La Pensee Sauvage.

Common Curriculum Examination Authority (CCEA) (2000) Specification for GCSE in Technology and Design – From September 2001, Belfast: CCEA.

Conant-Bryant, J. (1951) 'Science and Common Sense' in Green, J. *Contemporary Quotations*, London: Pan.

Design and Technology Association (DATA) (1994) 'A Survey of the Qualifications and Training Needs of D&T Teachers in Secondary Schools', *Research Paper No. 2* Wellesbourne, UK: DATA.

DATA (2021) *Design and Technology Association: Secondary*. Available at: <https://www.data.org.uk/for-education/secondary/> (Accessed: 13 February 2021)

Delahunty, T. and Kimbell, R. (2021) '(Re)framing a philosophical and epistemological framework for teaching and learning in STEM: Emerging pedagogies for Complexity'. *British Educational Research Journal* **47** (3) 742–769
DOI: 10.1002/berj.3706

Department of Education Northern Ireland (DENI) (1991) *Proposals for Technology and Design in the Northern Ireland Curriculum*. Report of the Ministerial Technology and Design Working Group, July 1991, Belfast: DENI.

Department for Education/ Welsh Office (1995) *Technology in the National Curriculum*. London: HMSO.

DeVries, M. (1994) 'Teacher Education for Technology Education' in Galton, M and Moon, B.(eds.) *Handbook of Teacher training in Europe: Issues and Trends*, London: The Council of Europe and David Fulton.

Dintersmith, T. (2018) *What School Could Be*. Princeton USA: Princeton University Press.

Doyle, A. (2020) 'Consolidating concepts of technology education: From rhetoric towards a potential reality'. *Unpublished PhD Thesis*, Stockholm: KTH, Institute of Technology, Stockholm.

Doyle, A., Seery, N. and Gumaelius, L. (2019a) 'Operationalising pedagogical content knowledge research in technology education: Considerations for methodological approaches to exploring enacted practice', *British Educational Research Journal*, **45** (4) 755–769.

Doyle, A., Seery, N., Canty, D. and Buckley, J. (2019b) 'Agendas, influences, and capability: Perspectives on practice in design and technology education' *International Journal of Technology and Design Education* **29** 143–159.

Doyle, A., Seery, N., Gumaelius, L., Canty, D, and Hartell, E. (2019c) 'Reconceptualising PCK research in D&T education: proposing a methodological framework to investigate enacted practice.' *International Journal of Technology and Design Education* **29** 473–491

Benjamin Doxtdator, B. (2022) Available at: <https://longviewoneducation.org/field-guide-jobs-dont-exist-yet/> (Accessed: 7 August 2022)

Duyar, I., T., Mina, D. K., and Owoh, S. J. (2019). Promoting Student Creative Problem-Solving Skills: Do Principal Instructional Leadership and Teacher Creative Practices Matter? in Tuncer Fidan (ed.) *Vocational Identity and Career Construction in Education*, Hershey, Pennsylvania: IGI Global, pp. 78-99.

Egan, K. (1992) 'A review of The Unschooled Mind', *Teachers College Record*, **94** (2) 397–441.

Engel, G and Green, T. (2011) 'Cell Phones in the Classroom: Are We Dialing up Disaster?' *TechTrends* **55** (2) 39-45.

ES (2018) Education Scotland National Improvement Hub - STEM Central Available at: <https://education.gov.scot/improvement/learning-resources/STEM%20Central> (Accessed: 4 June 2020)

- ETI (Education and Training Inspectorate(2010) ‘*Flexible PGCE Programme, with a focus on Literacy and Numeracy, The Open University*’, *Report of an Inspection in June 2010*, Belfast: ETI.
- Gardner, H. (1983) *Frames of Mind: The Theory of Multiple Intelligences*, New York: Basic Books.
- Gardner, H. (1991) *The Unschooled Mind*, New York: Basic Books.
- Gardner, H. and Boix-Marsella, V. (1994) ‘Teaching for understanding in the disciplines and beyond’, *Teachers' College Record*, **96** (2) 198–218.
- Gill, D. (2017) ‘Teaching Intermediate Technology Education in Newfoundland and Labrador’, *Unpublished EdD Thesis*, Calgary: University of Calgary, Canada.
- Gitomer, D.H. (2021) ‘Methods for Observing Classroom Interactions’ in Coe, R. Waring, M., Hedges, L.V. and Day Ashley, L. (eds.) *Research Methods & Methodologies in Education*, (Third Edition), London: Sage, pp. 221-230.
- Grossman, P. L., Wilson, S. M. and Shulman, L. S. (1989) ‘Teachers of Substance: Subject Matter Knowledge for Teaching’, in Reynolds, M. C. (ed.) *Knowledge Base for the Beginning Teacher*, Oxford: Pergamon Press.
- Grobler, R., Ankiewicz, P. (2021) ‘The viability of diverting from a linear to a parallel approach to the development of PCK in technology teacher education’. *International journal of technology and design education* Available at: <https://doi.org/10.1007/s10798-020-09644-4> (Accessed: 18 March 2022)
- Gunderson, S., Jones, R. and Scanland, K. (2004). *The Jobs Revolution: Changing How America Works*. New York: Copywriters Inc.
- Hallström, J., Hultén, M. and Lövheim, D. (2014) ‘The study of technology as a field of knowledge in general education: historical insights and methodological considerations from a Swedish case study, 1842–2010’, *International journal of technology and design education*, **24** (2) 121-139.
- Hallstrom, J and Williams, P.J. (eds.) (2022) *Teaching and Learning about Technological Systems*, Singapore: Springer
- Hammersley, M. (2021) ‘Research Ethics’ in Coe, R. Waring, M., Hedges, L.V. and Day Ashley, L. (eds.) *Research Methods & Methodologies in Education: Third Edition*, London: Sage, pp. 56-66.
- Hardy, A. (ed.) (2021) *Learning to Teach Design and Technology in the Secondary School. A Companion to School Experience*, (4th Edition), Abingdon: Routledge.
- Harrison, M.E. (1993) ‘Halfway there: reflections on introducing design and technology into the secondary phase’ in McCormick, R., Murphy, P. and Harrison, M. (eds.) *Teaching and Learning Technology*, Wokingham: Addison-Wesley.

Hasan, N., Ashraf, Md.M, Abdullah, A.B.M and Murad, Md.,W. (2015) ‘Mobile internet as a learning assistant for secondary and higher secondary students: the case of Bangladesh’ *Proceedings of the Australasian Conference on Business and Social Sciences 2015*, Sydney (in partnership with The Journal of Developing Areas) pp. 1296-1309.

Hwb (2022) *Curriculum for Wales: Science and Technology*. Available at: <https://hwb.gov.wales/curriculum-for-wales/science-and-technology/statements-of-what-matters/> (Accessed: 22 January 2022)

Jakovljevic, M. and Ankiewicz, P. (2016) ‘Project-based pedagogy for the facilitation of webpage design’ *International Journal of Technology and Design Education* **26** (2) 225-242.

Jawad, L.F., Majeed, B.H. and ALRikabi, H. Th. S. (2021) ‘The Impact of Teaching by Using STEM Approach in The Development of Creative Thinking and Mathematical Achievement Among the Students of The Fourth Scientific Class,’ *International Journal of Interactive Mobile Technologies* **15** (1) 172 -188

Jolles, J.W. (2021) ‘Broad-scale applications of the Raspberry Pi: A review and guide for biologists’ *Methods in Ecology and Evolution*, British Ecological Society, Available at: DOI: 10.1111/2041-210X.13652 (Accessed: 19 March 2022)

Jones, L.C.R (2016) ‘An Investigation into the Knowledge and Skill Requirements for Effective Teaching of Technology in English Secondary Schools’ *Unpublished PhD Thesis*, Loughborough: Loughborough University, UK.

Jones, L.C.R., McDermott, H.J., Tyrer, J.R., and Zanker, N.P. (2021) ‘The effect of teacher’s confidence on technology and engineering curriculum provision’ *International Journal of Technology and Design Education* **31** 117–137.

Kang, N-H. (2019) ‘A review of the effect of integrated STEM or STEAM (science, technology, engineering, arts, and mathematics) education in South Korea’, *Asia-Pacific Science Education* **5** (6) 1-22.

Kelani, R.R. and Gado, I. (2018) ‘Physical Science Teachers’ Attitudes to and Factors Affecting their Integration of Technology Education in Science Teaching in Benin’, *African Journal of Research in Mathematics, Science and Technology Education*, **22** (1) 81-92, DOI: 10.1080/18117295.2018.1436958

Kyriakides-Zenos, M., Banks, F. and Moon, B. (2002) ‘The Potential for the Use of Computer-Mediated Communication (CMC) in Teacher Professional Development’ in Banks, S., Goodyear, P. M., Hodgson, V. and McConnell, D. (eds.) *Proceedings of the 3rd international conference: networked learning 2002: a research-based conference on e-learning in higher education and lifelong learning*, Sheffield, University of Sheffield, March 2002, pp. 271- 278.

Kurup, P.M. and L. Xia (2022) ‘Building Preservice Teachers’ Confidence for Teaching and Learning STEM, Incorporating Innovative, Interdisciplinary, and Integrated (3I) Initiatives’ in Peters, M.A, (ed.), *Encyclopaedia of Teacher Education*, Singapore: Springer, Available at: https://doi.org/10.1007/978-981-13-1179-6_440-1 (Accessed 8 August 2022)

Layton, D. (1993) *Technology's Challenge to Science Education*, Buckingham: The Open University Press.

Leach, J. and Banks, F. (1996) 'Investigating the Developing "Teacher Professional Knowledge" of Student Teachers' *Paper at BERA Conference*, Lancaster, September 1996.

Leach, J. and Moon, B. (2008) *The Power of Pedagogy*, London: Sage.

Levin, C.; Klevorick, A. K.; Nelson, R. R.; and Winter, S.G. (1988) 'Appropriating the Returns from Industrial R&D' *Cowles Foundation Discussion Papers*. Available at: <https://elischolar.library.yale.edu/cowles-discussion-paper-series/1105/> (Accessed: 18 March 2022)

Martin, M. (2017) 'A Phenomenological Study of Pre-Service Teachers' Subject Knowledge in Secondary Design and Technology', *Unpublished EdD Thesis*. Liverpool: Liverpool John Moores University, UK

MacGregor, D. J. (2013) 'Exploring Professional Identity: Narrative Constructions of becoming and being a Teacher of Design and Technology Education', *Unpublished PhD Thesis*, Queensland: Griffith University, Queensland, Australia.

MacNamara, D. (1991) 'Subject knowledge and its application: problems and possibilities for teacher educators', *Journal of Education for Teaching*, **17** (2) 113-128.

Mammes, I. (2004). 'Promoting girls' interest in technology through technology education: A research study'. *Intentional Journal of Technology & Design Education*, **14** (2) 89-100.

McGarr, O. (2010) 'Education for sustainable development in technology education in Irish schools: a curriculum analysis.' *Intentional Journal of Technology & Design Education* **20** 317-33. <https://doi.org/10.1007/s10798-009-9087-7>

McLain, M. (2018) 'Emerging perspectives on the demonstration as a signature pedagogy in design and technology education'. *Intentional Journal of Technology & Design Education* **28** 985-1000.

McLain, M. (2021a) 'Key Pedagogies in Design and Technology' in Hardy, A. (ed.) *Learning to Teach Design and Technology in the Secondary School. A Companion to School Experience*, (4th Edition), Abingdon: Routledge.

McLain, M. (2021b) 'Towards a signature pedagogy for design and technology education: a literature review'. *Intentional Journal of Technology & Design Education*. Published online 10 April 2021 Available at: <https://doi.org/10.1007/s10798-021-09667-5> (Accessed: 8 August 2022)

McLain, M. (2021c) Developing perspectives on 'the demonstration' as a signature pedagogy in design and technology education. *Intentional Journal of Technology & Design Education* **31** 3-26.

Macleod, I. (1969) 'Open University is "Blithering nonsense" - *Daily Telegraph*, 17 February 1969.

McCormick, R. and James, M. (1987) *Curriculum Evaluation in Schools* (2nd Edition) , London: Crown Helm.

McCormick, R. (1993) 'Technology education in the UK', in McCormick, R. Murphy, P. and Harrison, M.(eds.) *Teaching and learning technology*, London:Addison-Wesley.

McDiarmid, G., Ball, D. L., and Anderson, C.W. (1989) 'Why staying one chapter ahead doesn't really work: subject-specific pedagogy' in Reynolds, M. C. (ed.) *Knowledge Base for the Beginning Teacher*, Oxford: Pergamon Press.

McEwan, H. and Bull, B. (1991) 'The pedagogic nature of subject matter knowledge', *American Educational Research Journal*, **2** (2) 319–34.

Mears, C.L. (2021) 'In-depth Interviews' in Coe, R. Waring, M., Hedges, L.V. and Day Ashley, L. (eds.) *Research Methods & Methodologies in Education*, (Third Edition), London: Sage, pp. 232-239.

Millar, R. (1987) *Teaching Physics as a Non-Specialist*, York: Department of Education, University of York.

Ministry of Education and Vocational Training. (2000). *Policy and Investment Framework*. Lilongwe, Malawi: Malawi Ministry of Education.

Moon, B. and Banks, F. (1996) '*Secondary school teachers' development: reconceptualising knowledge and pedagogy*'. Paper at *Association for Teacher Education in Europe (ATEE)*, Glasgow, September 1996.

Munshi, P.and Bhatti,T. (2009) 'Quality assurance in teacher education programmes offered through distance mode in Pakistan' *The Sakarya University Journal of Education*, **38** 1-17.

Murphy, P. (2006). Gender and technology: Gender mediation in school knowledge construction. In J. Dakers (ed.), *Defining technological literacy*, New York: Palgrave pp. 219-237.

Niiranen, S. (2021) 'Supporting the development of students' technological understanding in craft and technology education via the learning-by-doing approach'. *Intentional Journal of Technology & Design Education* **31** 81–93 <https://doi.org/10.1007/s10798-019-09546-0>

Norström, P. (2013) Engineers' non-scientific models in technology education. *International Journal of Technology and Design Education* **23** 377–390 <https://doi-org.libezproxy.open.ac.uk/10.1007/s10798-011-9184-2>

Oluwale, B.A., Jegede, O.O. and Olamide, O.O. (2013) 'Technical and vocational skills depletion in Nigeria and the need for policy intervention' *International Journal of Vocational and Technical Education*, **5** (6) 100 – 109.

Øvrebø, L.J., Dyrstad, D.N., Britt S. Hansen, B.S.(2022) 'Assessment methods and tools to evaluate postgraduate critical care nursing students' competence in clinical placement. An integrative review', *Nurse Education in Practice*, **58**.

Parlett, M. and Hamilton D.(1972) *Evaluation as Illumination: a new approach to the study of innovatory programmes*, Edinburgh: University of Edinburgh.

Pitt, J. (1991) 'Design and Technology and Social Responsibility' *Design and Technology Teaching* **24** (1) 34-36.

Razali, F. (2021) 'Exploring Crucial Factors of an Interest in STEM Career Model among Secondary School Students', *International Journal of Instruction*, **14** (2) 385-404.

Shohel, M. M. C. (2010). *Transition from non-formal to formal education in Bangladesh: An exploration of the challenges students face*. Saarbrucken: LAMBERT Academic Publishing (LAP).

Shohel, M. M. C. and Power, T. (2010). 'Introducing mobile technology for enhancing teaching and learning in Bangladesh: teacher perspectives' *Open Learning: The Journal of Open and Distance Learning*, **25** (3) 201-215.

Shohel, M.M.C. and Banks, F. (2010) 'Teachers' Professional Development through EIA Secondary Teaching and Learning Programme in Bangladesh: Experience from the UCEP Schools'. *Procedia - Social and Behavioural Sciences Journal*, **2** (2) 5483-5494 Available at: doi:10.1016/j.sbspro.2010.03.894 (Accessed 8 August 2022)

Shohel, M.M.C. and Banks, F. (2012) 'School-based teachers' professional development through technology-enhanced learning in Bangladesh' *Teacher Development*, **16** (1) 25-42.

Shohel, M. M.C. and Kirkwood, A. (2012). 'Using technology for enhancing learning in Bangladesh: challenges and consequences.' *Learning, Media and Technology*, **37**(4) 414 - 428.

Shulman, L. S. (1986) 'Those who understand: knowledge growth in teaching', *Educational Research Review*, **57** (1).

Shulman, L. S. and Sykes, G. (1986) 'A national board for teaching? In search of a bold standard'. *A report for the task force on teaching as a profession*, New York: Carnegie Corporation.

Shulman, L. S. (1987) 'Knowledge and teaching: foundations of the new reform', *Harvard Educational Review*, **57** 1-22.

Sizer, T. R. (1992) *Horace's School*, New York: Houghton and Mifflin.

Smithers, A. and Robinson, P. (1992) *Technology in the National Curriculum: Getting it Right*. London: The Engineering Council.

Stake, R. (1967) 'The Countenance of educational Evaluation' *Teachers College Record* **688** (7) April.

Stein, S.J., Ian S. Ginns, I.S., McRobbie, C.J. (2000) 'An Integrated Approach to Describing Technology Education Classrooms' in *Proceedings of the 2nd Biennial International*

Conference on Technology Education Research held at the Parkroyal Gold Coast, Australia, 5 – 7 December 2002.

Stein, S.J., Ian S. Ginns, I.S., McDonald, C.V. (2007) 'Teachers learning about technology and technology education: Insights from a professional development experience', *International Journal of Technology and Design Education* **17** 179–195.

Stenhouse, L. (1982) 'The conduct, analysis and reporting of case study' in McCormick, R. (ed.) *Calling Education to Account*, London: Heinemann

SQA (2022) *Practical Electronics* Available at: <https://www.sqa.org.uk/sqa/47460.html> (Accessed: 22 January 2022)

Syafrill, S. RahayU, T., Al-Munawwarah, S. F., Satar, I., Halim, L. Bt., Yaumas, N.E. and Pahrudin, A. (2021) 'Mini review: Improving teachers' quality in STEM-based science teaching-learning in secondary school', *Journal of Physics: Conference Series*, London: Institute of Physics. doi:10.1088/1742-6596/1796/1/012072

Tochan, F. and Munby, H. (1993) 'Novice and expert teachers' time epistemology: a wave function from didactics to pedagogy', *Teacher and Teacher Education*, **9** (2) 205–18.

Underprivileged Children's Education Project (UCEP) (2009) Available at: <https://www.ucepbd.org> (Accessed: 13 January 2022)

Verret, M. (1975) *Le temps des études*, Paris: Librairie Honoré Champion.

Wragg, E.C. (1987). *Conducting and Analysing Interviews*, Rediguide 11: Guides in Educational Research, Nottingham: University of Nottingham School of Education.

Webb, C.L. (2013) 'Cell Phones in the Classroom: Don't Put Them Away Just Yet!' *Kappa Delta Pi Record*, **49** (4) 180-183. DOI: 10.1080/00228958.2013.845508

Wilson, S. M. and Wineberg, S. S. (1988) 'Peering at history through different lenses: the role of the disciplinary perspectives in teaching history', *Harvard Educational Review*, **89** (4) 527–39.

Wilson, S. M., Shulman, L. S. and Richert, A. (1987) '150 different ways of knowing: representations of knowledge in teaching', in Calderhead, J. (ed.) *Exploring Teacher Thinking*, New York: Holt, Rinehart and Winston.

Winn, D. (2021) 'Developing Links with Other Subjects' in Hardy, A. (ed) *Learning to Teach Design and Technology in the Secondary School. A Companion to School Experience*, (4th Edition), Abingdon: Routledge, pp. 273-288.

Yang, Y. (2010) 'Roles of Administrators in Ensuring the Quality of On-line Programs' *Knowledge Management & E-Learning: An International Journal*, **2** (4) 353-369.

Zenios, M., Banks, F. and Moon, B. (2004) 'Stimulating professional development through CMC - A case study of networked learning and initial teacher education' in Goodyear, P.,

Banks, S., Hodgson, V. and McConnell, D. (eds.) *Advances in Research on Networked Learning*, Dordrecht, Netherlands: Kluwer, pp. 123-152.

Appendix 1 – Reviews of Publication 16

1st Edition

Prof Tim Lewis

Teaching STEM in the Secondary School. Helping teachers meet the challenge.

Frank Banks and David Barlex. New York, Routledge, 2014

I'm sure most of us have read a lot about STEM (Science, Technology, Engineering and Mathematics) in documents such as research papers, journal articles, government documents and the media, but this book is different.

While it draws on the authors' undoubted knowledge of STEM on an international front, with references to documents from numerous international sources, this book is more down to earth and is about STEM as it is in UK schools, with the added vision of how it could be if the opportunities were fully explored. The book is not written in the usual academic prose normally used for education books, it is written in what is best described as a 'conversational style'; at times I found myself asking questions such as 'what if?' and 'but can't we do that?' and, on several occasions, disagreeing with the authors by thinking 'no that can't be right!' Occasionally there is an element of humour which adds to the enjoyment of reading this book. This style of writing an educational text is particularly welcome at a time when teachers and trainee teachers have become used to the usual list of bullet points and tick boxes. Part of this readability is achieved by the authors using case studies, cameos and examples thus ensuring the book is a realistic view of STEM in schools.

Who is this book for?

The text on the cover says '*essential reading for trainee and practicing teachers*' however I suggest that this book is also essential reading for senior leaders in schools such as headteachers and curriculum deputies who need to gain a very clear understanding about the educational opportunities available within STEM subjects.

Format of the book

In the introductory chapter about the nature of STEM the authors raise issues such as the relationship between science and technology, a topic that seems to recur periodically in the book and is not fully resolved. It is chapter two, where they start to show the way they think about STEM, the title '*A curriculum for STEM — 'looking sideways'*' (page 25) says it all; numerous examples of good practice mainly from schools that introduce the reader to a range of educational initiatives that have and are still influencing STEM implementation in schools. A section headed '*Sharing teachers' professional knowledge*' (page 33) includes a theoretical example of how STEM can help teachers gain an understanding of sharing the curriculum and yet establish a personal construct to inform their pedagogical practice. This is encapsulated in a simple but very effective diagram (page 34) that must be useful to anyone involved in teacher education.

It is in this chapter that an element of confusion creeps in as the previously discussed relationship between science and technology is exacerbated by the statement '*science and design & technology are so significantly different from one another that to subsume them under a 'science and technology' label is highly dangerous.*' (page 41). Perhaps this clarifies the confusion! At several points in this book, I thought the authors, both with a science background, were talking themselves out of being scientists and into being technologists, but then the old problem of what design & technology is compared with technology (as used by many countries) raised its head.

The authors, both with a thorough understanding of D&T through their international curriculum development activities and teacher education responsibilities, make a good job of trying to rationalise this but it remains an unresolved issue. This curriculum analysis chapter concludes with a statement that we could all take to heart. *'If teachers 'look sideways' pupil learning can be enhanced.'* (page 46). A very true statement.

Analysis of the each of the STEM subjects

As expected, each of the subjects contributing to STEM is allocated a separate chapter each with an analysis using quotes from distinguished authors and published texts however what makes this book so useful is the inclusion of numerous examples of how the subjects can capitalise on STEM. These examples are realistic and achievable, the theme being subjects cooperating in the development of teaching and learning materials. In the chapter *'Teaching Science in the light of STEM'* (page 48) the authors introduce the notion of teachers talking to each other. This becomes a strong thread in the book binding each section together. A second, but equally valid thread, is the importance of project work and project-based learning (PBL) as these features in virtually every chapter. The science chapter starts with a short historical review with quotes from eminent authors and curriculum developers identifying the strengths and weaknesses of the way science is approached in UK schools. The possible relationship with D&T is a strong element in this analysis particularly with a recognition of the work by David Layton to the point of quoting the controversial statement *'the acquisition of scientific knowledge is inescapably tinged with dogmatism'* (Layton D, 1975) (page 50). Inevitably the examples given for consideration by teachers, and particularly suitable as STEM curriculum development, have a science base but are presented as being ideal for discussion with other STEM teachers thus demonstrating how *'dogmatism'* can be broken down. In the chapter dealing with D&T the subject is dealt with in a similar way with the addition of how D&T, through the D&T Association supported by higher education, design, engineering and manufacturing industries dealt with recent negative political interventions. Unfortunately, the authors consider the starting point for D&T was in 1988 with the introduction of the UK national curriculum ignoring the fact that much of D&T curriculum development occurred prior to this in the 1970's and 80's supported by projects such as the Schools Council funded Modular Technology, Microelectronics For All (MFA) and Design & Craft. Similarly, more recent curriculum development initiatives such as the Digital D&T programme are not included although the Technology Enhancement Programme (TEP) gets a brief mention (page 161). Torben Steeg, an experienced educational researcher and consultant, (page 77) uses his in-depth knowledge of both science and D&T to provide an illuminating interview promoting interesting practical ideas for co-operation between D&T, science and mathematics. As with science the D&T curriculum development examples provide exciting opportunities for teachers and their pupils with no fewer than seven realistic examples of how D&T and maths could work together. While the text of this chapter, with the examples, encapsulates the learning embedded in pupil research and designing activities there seems to be a lack of recognition that making processes require similar levels of intellectual engagement as pupils use materials, tools, equipment and machinery to turn their ideas into reality.

I expected 'E' for engineering to follow next only to find it is 'M' for mathematics! (page 100) Engineering seems to be relegated to a later chapter titled *'Enabling the 'E' in engineering'* (page 151). The opportunities for mathematics within STEM are introduced using an amusing, but serious analogy, and then are dealt with in the same way as science and technology (D&T). The authors cite OfSTED reports and several eminent experts such as Vorderman and Porkess (page 103) who paint a picture of concern about the lack of popularity of mathematics in schools and express major anxieties about the way it is taught. This is balanced by a discussion about initiatives such as the case study approach developed by the National Centre

for Excellence in the Teaching of Mathematics (NCETM) until recently directed by Professor Celia Hoyles whose interview with the authors provides ideas for capitalising on the relationship between technology (D&T) and mathematics identified in an earlier chapter. As in previous chapters this is followed by examples of collaborative ventures between subjects although these seem to have a more scientific focus, this is recognised by the authors with the comment that science and D&T teachers '*will be able to identify many more examples*' (page 133). Surprisingly ventures such as Class Of Your Own (COYO), an emerging UK initiative, that focuses on mathematics in real life situations such as surveying in civil engineering and the construction industries is not included. (<http://designengineerconstruct.com/>)

Eventually I came to the 'E' for engineering in STEM and this chapter is in an entirely different format. A major part of it is a presentation by Professor Mathew Harrison, until recently Director of Education at the Royal Academy of Engineering, in which he presents a convincing case for engineering being a school subject backed up by recent facts and figures with quotes from numerous published reports. His main thrust can be summed up as engineering is the one subject in the STEM agenda that pulls together all of the subjects and these link into manufacturing and engineering industry. This is an impressive report on the recent history and successes of engineering in UK schools however it does raise the controversial in the UK, question of whether engineering is a vocational subject. This is followed by the authors' discussion dealing with issues raised by Mathew Harrison, again using their questioning style that effectively thus puts the reader in the position of decision maker. The USA STEM model, where engineering is seen as part of science, is explored with considerable detail and the authors make a convincing case that this model is unlikely to work in the UK and a collaborative model is more appropriate. A figure of '*more than 5,000 teachers*' (page 166) with engineering degrees is given as being the number employed in UK secondary schools mostly engaged in teaching STEM subjects. Surely, they are ideal people to initiate or take part in discussion of this type at school level. The authors well balanced debate concludes that if engineering is to be a successful part of the school curriculum it will require considerable co-operation between science, D&T and mathematics teachers reinforcing, once again, teachers talking to each other. Unfortunately, the authors deviate from their established format by not including examples of engineering project work and exemplary teaching and learning opportunities. Bearing in mind that until recently the UK had 70+ engineering schools under the Specialist Schools and Academies Trust (SSAT) scheme many developing outstanding STEM teaching and learning materials that are worthy of inclusion in this book.

A message that permeates the four chapters dealing with each of the STEM subjects is that curriculum development in the UK seems to be rather haphazard. For example, in the mathematics chapter the authors enthuse about D&T project opportunities using four bar linkages as part of animated toy projects (pages 122, 123). This knowledge was part of geometric and engineering drawing (GED) some 40 years ago and did result in well-motivated pupils engaging with interesting paper-based design activities.

Why was this abandoned? The authors are right - the four-bar linkage with a mathematical analysis is an ideal opportunity for toy design in D&T providing it is updated to a computer aided design (CAD) based activity. To underpin this notion of updating important aspects of the curriculum the authors recount working with a group of science trainee teachers on acceleration using Fletcher's trolley which many readers may remember from their physics lessons. The task was to update this using data logging and IT to retain the learning but make it more accessible to pupils (pages 201, 202). So science teachers were able to reinvigorate this essential learning. There

is an interesting message in the chapter on IT that, in the light of STEM, the contributing subjects could revisit essential parts of their curriculum and update in a similar way.

Project based learning

The project based pedagogical thread mentioned previously is aligned with problem-based learning (PBL) and brought together in a chapter (page 135) set out in an accessible format of question-based headings such as *'How are successful project-based learning and related tasks organised?'* (page 144) and, important to the D&T teacher, *'Teaching knowledge when needed, or as structured development and the relative importance of skills'* (page 145). This chapter is particularly relevant to D&T trainee and practicing D&T teachers as it provides considerable detail about how to plan and manage design and make assignments, including assessment. The authors draw on the recommendations of the D&T Association to consider planning a programme of study using *'small tasks'* and *'big tasks'* (page 145) to ensure coherence in the learner's experience. It is a comprehensive chapter concluding once again with the all-important thread *'regular conversations with colleagues'* and the additional recommendation of *'teamwork'*.

Making STEM work

Several shorter chapters provide insight into how STEM can be pulled together in schools. The chapter titled *'The role of STEM enhancement and enrichment activities'* (page 175) is packed with fascinating information covering numerous examples of competitions and after school activities, many from overseas providing an international perspective about what is possible. The authors have done considerable research into this aspect of their book the result being a sort of directory of 'a good fun guide to STEM'. Particularly pleasing is the detail of more local initiative developed by a UK based D&T teacher who puts a 'D' into STEM providing design days and design camps for students. As a result of reading this chapter I found myself following up many of the initiatives searching for further information on the internet, I'm sure most STEM teachers would find doing this an inspirational experience as there are so many worthwhile schemes. The chapter finishes with a questioning conclusion of *'Why is the school experience so impoverished that stakeholders feel the need to initiate enrichment activities outside the mainstream school provision'* (page 194). I'm certainly not sure about the answer but it is a question that teachers involved in STEM subjects could seek their answer. It is a point well made.

Similarly, the chapter *'Computing and digital literacy, IT, computer science, TEL and STEM'* (page 197) is invigorating as it presents the reader with ideas for development. Headings such as *'IT and science'* (page 201) and *'IT and mathematics'* (page 207) are obvious but are supported by examples and cameos suitable for schools thus demonstrating the opportunities IT provides for teachers to develop creative teaching and learning situations for their pupils. For D&T and engineering the inclusion of *'systems for controlling artefacts'* (page 206) is a comprehensive list of suitable soft and hardware followed a list of eight projects each starting with *'design and make'* underlining the importance of the making activity. A feature of these seems to be how systems and control can be harnessed by the 'pupil designer' rather than just learning about control systems and software.

Concluding chapters

While these chapters, *'Creating and environment for sustaining STEM'* (page 216) and *'Future vision for STEM'* (page 238), are important to all readers they are particularly relevant to school leadership teams as they provide insight to how STEM can provide a balanced curriculum. By presenting ideas such as *'considering mathematics'* and *'considering technology'* the authors précis the previous in-depth commentary with additional material drawn from international

sources. Amongst many examples I found two that are particularly noteworthy. The first is a long quote from David Hargreaves (page 233) who uses a gardening metaphor in a discussion about generating ideas and managing knowledge creation. This is particularly relevant to senior management teams in schools. The second is the STEAM (Science, Technology, Engineering, Arts, Mathematics) (page 252) movement in the USA which is likely to be of interest to some D&T departments in UK schools. (<http://www.steamedu.com/>). It would be easy for the authors to impose their vision for STEM but they steadfastly resist this saying *'Clearly we, as authors of the book, cannot and should not define the future vision for STEM. Any attempt would be futile, and the fact is that it is your vision in your school that is important and only you can decide on and work towards that.'* (page 254)

Conclusion

This is the most comprehensive and interesting book about STEM in schools I have read. The style of writing ensures the wealth of research, information, ideas, and examples of good practice are accessible to teachers, trainee teachers and any educationalist involved in these subjects including those in education management positions. This book is a leap forward for STEM in schools. Enjoy reading this book and then heed the authors' advice and talk to colleagues about it.

Prof. Marc de Vries

Teaching STEM in the Secondary School. Helping teachers meet the challenge.
Frank Banks and David Barlex. New York, Routledge, 2014

The authors of this book are probably well known by many of our readers, as they have published several articles in previous issues. Both are long-term experts in the field and have a wide-ranging experience in both developing curriculum material and educating teachers. Truly a strong team to put together a book on teaching about technology. But not only about technology. Banks and Barlex have taken up the challenge to come up with a first practical guide for teaching STEM. This book hopefully will become a counterpart of other publications emerging from science education, in which often the nature of technology and design remains more explicit than we in technology education would wish. Finding opportunities for really integrating the STEM disciplines, Science, Technology, Engineering and Mathematics is by no means easy and the authors are to be complemented for their accomplishment. In that respect the Table of Contents at first sight seems a bit disappointing, because it contains chapter titles like 'Teaching science in the context of STEM' and 'Teaching math in the context of STEM', which suggests that the individual disciplines still remain visibly separated. Banks and Barlex do, however, also pay attention to integrated STEM Education in which the contributing disciplines blend together. The E in STEM is already a challenge in itself, given the general lack of experience we have in teaching pre-university engineering education. For that reason, the authors have spent a separate chapter on that (Chapter 7). Let us now turn to the individual chapters to see what the book offers. Chapter 1 introduces the idea of STEM education. Both in the UK and in the USA politicians have emphasized the importance of the STEM disciplines (mark the plural: disciplines). In the course of time, several initiatives have been taken to support the teaching and learning of science, technology and math, as the authors show in Table 1.1. They point out that technology is not just applied science, if only for the fact that many inventions were made without proper knowledge of the underlying phenomena. But obviously there are relations between science, technology and math. The authors show this by a simple imaginary classroom assignment. The authors also show how STEM educational so contributes to more general skills and attitudes, such as problem solving and systems thinking.

Chapter 2 then shows different ways to go in STEM education: by a coordinated approach, a collaborative approach and an integrative approach. It makes quite a difference if the chosen approach is only present in formal documents or really happens in practice. The authors therefore distinguish between the specified curriculum (what is in the documents), the enacted curriculum (what teachers really do) and the experienced curriculum (what pupils learn). In literature sometimes as fourth is mentioned: what people think has happened. When you ask teachers what approach they take, that may be quite different from what one observes in their classes. The role of the teacher, of course, is very important and for that reason Banks and Barlex pay explicit attention to what teachers need to know.

Their model consists of subject knowledge, school knowledge, pedagogical knowledge and—in the middle of the other circles—personal subject construct. Here one would have expected the term ‘pedagogical content knowledge’ (PCK), but for some reason, not accounted for in the text, the authors seem to reject that term.

The three following chapters elaborate teaching the three disciplines science, design & technology and mathematics in the context of STEM. The term design & technology reveals the UK flavour that the book has, although the authors do look around worldwide in the text, as one would expect from two colleagues who have been so active in international conferences and projects. Chapter 3 is about science. The authors both have their background in that discipline (by the way, it is funny that we sometimes hear them speak as ‘I’, without letting us know whether it is Banks or Barlex speaking at that point). The authors use seven examples to show how the learning of ‘big ideas’ in science is enhanced by using design assignments. Evidently, design & technology thus becomes the core of STEM. This will be new to many science teachers, who do not have design in their PCK (or personal subject construct, in the authors’ terminology). The authors acknowledge that and dedicate a special section in the chapter to continuing professional development for science teachers.

The authors also make clear that the integrity of learning the nature of science is not necessarily hurt by teaching it in the context of STEM. Chapter 4 continues with teaching design & technology in the context of STEM. Having read Chapter 3, Chapter 4 confused me. What is the difference between the two chapters? Again, we find good examples of how design assignments can contribute to understanding science (and math). Chapter 3 emphasized cooperation between the science teacher and the design & technology teacher, and the same is suggested in Chapter 4. I would have expected the learning of design itself as the main focus of this chapter, but that is not really the case. Of course, we get to know design better when we learn to acknowledge that science and math play a role in it, but that does not make us more aware of the fact that design & technology has its own unique features. It is also striking that in this chapter there is no section on continuous professional development for design & technology teachers. It is my experience that for many of them, who have no background in science, working with the science teacher can be extremely demanding. I am absolutely sure the design & technology teachers’ PCK needs further development if ever a proper relation between teaching the science and teaching the design & technology content is to be successful. Chapter 5, on teaching math in the context of STEM, puts the matter more or less in the context of the growing concern about math education in the light of PISA and TIMSS results. Some initiatives to improve the situation are described (for instance, the Khan Academy). Teaching math in the context of STEM is then presented as a possible contribution to improving math education. Again, we find several convincing

examples in the text. All examples in the three chapters are quite inspiring and these alone already make the book a worthwhile contribution to the development of STEM education.

Real integration of the STEM disciplines is suggested in Chapter 6 that deals with project work and problem-based learning (PBL). The authors seem to treat the terms ‘project-based learning’ and ‘problem-based learning’ separately (they also describe features of each), but the assumed differences remain unclear. To the best of my knowledge, the abbreviation PBL in literature is even used for both. Having read the previous chapters, again the question comes up: what is new? We see nice examples again, but not fundamentally different from the ones we saw in earlier chapters, apart from the fact that they seem to require some more time now (although I would doubt that for some examples in Chapters 3 through 5).

As I wrote before, the ‘E’ in STEM is a challenge in its own right. Chapter 7 takes up that challenge. The first part of this chapter is written by Matthew Harrison, Director of ‘Engineering and Education’ at the Royal Academy of Engineering (presumably in England). The authors then comment on that and consider the option of having Engineering as a separate school subject (Harrison mainly mentions extra-curricular activities). Finally, they discuss the efforts in the USA to implement pre-university engineering education. I got the impression that in Harrison’s contribution to this chapter, the difference between (design &) technology and engineering mainly lies in the fact that engineering is a profession and that engineering education for that reason is a form of vocational education. Fortunately, the authors point out that there is an alternative view, as proposed by the USA National Academy of Engineering, in which certain disciplinary characteristics can serve to make the difference: developing and using models, analysing and interpreting data, engaging in argument from evidence, as in contrast with a more qualitative and intuitive approach in design and technology. That, to me, seems to be a more fruitful way for bringing in the E in STEM, as it could serve as a bridge between (design &) technology on the one hand and science and math on the other hand.

The remaining chapters deal with practical aspects. Chapter 8 offers a description of various projects that aimed at enrichment of science, technology and math education. Chapter 9 deals with the role of computing and ICT in STEM. Both in terms of learning *with* ICT and learning *about* ICT (digital literacy). As in previous chapters, the authors offer a rich collection of ideas. Chapter 10 is about creating a proper environment for STEM education: a proper physical environment, a proper educational psychology environment and a proper professional environment. Chapter 11 closes the book with some future perspectives. Banks and Barlex first show the unsolved problems when each of the STEM disciplines remains isolated. Then they use views put forward by colleagues from Israel, Brazil and the USA to show the value of more integrated STEM. Finally, the authors hand over to their readers: what are your ambitions to realise STEM education in your school? Having provided such a rich source of inspiration, I think the authors are entitled to expect better answers than: “I do not know”. I hope this book will stimulate real STEM education, not only in England, but also in other countries

Reviewed by Peter Campbell **Physics Education**, September 2014, pp. 608-609.

The primary audience for this book is teachers of science, technology, engineering and mathematics. It explores the advantages for these teachers in 'looking sideways' to see what their colleagues are doing in the other STEM subjects. It strongly encourages them to talk and collaborate, in order to improve students' learning experiences and progression.

Both of the authors began their careers as science teachers in comprehensive schools (one of them teaching physics, the other chemistry) and ultimately moved into higher education, with responsibility for training technology teachers. Drawing on a wealth of education research and policy literature and in a fluent writing style, they discuss the nature of each of the STEM subjects, curriculum politics in many countries, curriculum innovations at school level and especially the role of teachers. Necessarily they also discuss the nature of learning and what characterizes good teaching. They examine what happens in schools, in the context of international calls for education to underpin industrial innovation.

The book is well structured. Two opening chapters review the history of STEM education, with a general discussion of what different STEM subjects share in common and how they differ. In seven central chapters packed full of detailed illustrative case studies, the authors describe and evaluate different curriculum models for STEM teaching and learning, each chapter from the perspective of a particular curriculum area: science, design and technology, mathematics, engineering, computing and information technology, project work and problem-based learning, and enhancement and enrichment activities. Two final chapters consider how schools can create an environment for sustaining STEM education and present some future visions for STEM. Every chapter ends with a good bibliography of background reading and references.

In England today, external factors drive secondary schools to optimize their students' exam performance, with detrimental effects on cross-curriculum coordination and planning. Yet, says John Holman in a foreword, 'parents want more from schools than examination performance alone. They want their daughters and sons to be inspired by their teachers, to develop skills of leadership and teamwork and to be employable when they move on from school. These qualities don't come from mere examination preparation: they need a style of teaching that aims to engage curiosity and inspire further study'.

Two other quotations resonate strongly. The Roberts 2002 UK report *SET for Success* describes a 'widespread concern that science is taught in a way that does not appeal to many pupils and that the curriculum places too much emphasis on rote learning rather than on relating theory to situations relevant to the pupil'. Elsewhere Philip Adey summarizes, 'What the research shows consistently is that if you face children with intellectual challenges and then help them to talk through the problems towards a solution, then you almost literally stretch their minds. They become cleverer, not only in the particular topic, but across the curriculum'. The book makes plain a need for more coordinated approaches to STEM education and shows a variety of ways that this could be achieved. I recommend it as a 'one-stop shop' for teachers, teacher educators and education policymakers. Indeed, it is a valuable read for anyone who might help to release the education potential of more joined-up STEM education.

2nd Edition

Andy Mitchell, Independent Consultant, UK

Banks, F. and Barlex, D. (2021) Teaching STEM in the secondary school: Helping teachers meet the challenge

This book explores the purpose and pedagogy of STEM (Science, Technology, Engineering and Mathematics) teaching and the ways in which STEM subjects can interact in the curriculum, to enhance student understanding, achievement and motivation. Publication of this second edition is particularly apposite, considering the current world under COVID 19. As reported daily in the media, STEM is at the heart of providing the solution to the pandemic. Perhaps this represents the most significant ever worldwide bringing together of the individual elements of the construct to address a common goal. In terms of education, this should only serve to promote further the benefits of cross curricular study, working in teams and the benefits to learning in terms of knowledge application not simply acquisition.

Cross curricular working, continues to be an elusive objective in many schools, not helped by the strictures of public examination systems. But the authors argue there has never been a better time to consider new ways of constructing a relevant curriculum. Not least as it best reflects the world beyond education. 'With regard to interaction between the subjects, it is becoming increasingly clear that the problems now facing the world will need robust interdisciplinary teams for their solution hence an interaction at school level might be a useful precursor. (p.53)

But the book's publication is pertinent for a second reason. From at least a UK perspective of design and technology (D&T) education, coping with the persistent challenge of employing sufficient subject trained specialists, extending design and technology teaching teams to include teacher colleagues with non-D&T backgrounds but related expertise may offer a solution. At a time when D&T is perhaps experiencing its lowest status in its history, the opportunity to use creative timetabling and collaboration with computing, science but also art and design, to revitalise both its teaching and perception, could offer interesting possibilities. Whether or not this way of working adopts the acronym STEM (the use of which is contested in some quarters), securing the fundamental of D&T teaching that makes more formal use of shared knowledge skills and understanding can only be of benefit to learners.

Central to the book's purpose, is the proposal that teachers need to look beyond their own subject, to create teaching and learning experiences that make sense of and enrich science, technology and mathematics. Indeed, the problems of siloed organisation of learning which fails to exploit the relationship between different subjects, one could argue has long held back learning. Chapter 2 refers to this as 'Looking sideways' But key is the consideration of the silent 'D' for design and the vital role that design and technology plays, not least in providing meaning, context and purpose. Throughout, concepts are explored through each contributory subject. Too often the label STEM is applied incorrectly and frequently describes work that is much narrower in nature than the construct implies and is restricted to mathematics and science. The book provides an excellent justification for STEM but also defines it in much more inclusive terms.

Those who found useful the first edition of the book published in 2014, will not be disappointed by this revision. It has been significantly updated and contains a good deal of additional content.

This book will be particularly useful to schoolteachers, interested in both curriculum development in their workplace and their own personal development. It provides an accessible source to inform their thinking and draws together perspectives from the contributing disciplines, key authors and initiatives that underpin STEM education. It should also feature in indicative reading lists for initial teacher education (ITE), assisting student's development of their ability to draw links between subjects and understand better their own subject's contribution.

The authors share considerable experience of working in various fields, including science, design and technology, teaching in schools but significantly providing teacher education. Barlex in particular has a considerable reputation for his contribution to D&T curriculum development and the publication of resources to support teaching and learning. Perhaps the best known of which is the Nuffield Design and Technology Project (2000); and also, the Young Foresight resource (2000), a 12-week programme for 14-year-olds, making use of industry links and designed to stimulate creativity by challenging orthodox practise in design and technology. The contents of both are referred to for illustrative purposes.

As a text, it also provides a very useful reader for senior leaders and curriculum planners in school, looking for ways to managing and sustain STEM approaches. Even if coming from one of the STEM subjects, it will help them become more conversant with each subject's potential contribution. If a school were to embark on developing STEM an initiative, not least those that have already taken the decision not to include D&T in the curriculum, then this book would provide an excellent introduction to promoting discussion and ensuring a common understanding.

The scenario of entering the post pandemic world to which we hope to return, adds further weight. Even when we return to life more similar to pre-March 2000, the education world will never be the same again. Addressing D&T's precarious position in many schools will depend entirely on its community being proactive, rising to the challenge and embracing the opportunities presented. Whenever we overcome Covid-19 and its variants, we cannot expect a massive investment in education to follow. Many countries including the UK will be financially challenged. Certainly, it is unlikely that D&T will be prioritised. However, in some situation, STEM might be.

The book is helpfully laid out, each chapter encouraging further exploration with the inclusion of extensive and useful recommended reading lists. This alone, serves as a very useful bibliography for scholars, not least those undertaking courses in ITE. Most chapters also contain a short conclusion and additional reading list. This may help the reader to 'dip into' the book, quickly identify issues of immediate interest to them.

The book is well illustrated contributing to its accessibility. However, the range of figures is largely restricted to diagrams and resources. Difficult though it often is to collect actual examples of STEM outcomes emanating from schools, considering the practical nature and physical outcomes of the type of activity advocated, it is perhaps disappointing these are under-represented. Chapter 9: Computing, digital competence, computer science, TEL and STEM is a case in point. The section: Computing in design & technology and engineering lesson (p.193) provides a comprehensive list of the ways in which IT has massively extended the range and capability of young people working in D&T and in STEM contexts. If photographs of student's application of microprocessors or CAD and additive manufacture,

harnessed to facilitate outcomes, until recently beyond the capability of schools had been included, it would have been compelling. This would also have provided opportunity to include contemporary, different and perhaps more imaginative examples of D&T and engineering, the type of which we should be promoting today.

Including separate chapters to consider STEM from the standpoint of each subject specialism may well provide an 'in' for the reader, eager to understand first, how their own specialism is represented. For example, Chapter 7: 'Enabling the 'E' in STEM'.

A welcome new addition is provided by Chapter 11: Looking at STEM education in different countries. In this section authors from Australia, Belgium, Brazil, China, Israel, Russia, Taiwan, and the USA write about STEM education in their particular countries. Each piece has been extracted from a longer piece, all of which can be found at the website <https://dandfordandt.wordpress.com>.

What follows are fascinating examples of how STEM education has been approached in each country, which add to the ideas throughout the book, that will provide stimulus for teachers to develop their own activity. The overcoming of challenges reported in scenarios is interesting but also the conveying of a sense of the opportunities created.

In Belgium (p. 240), we read of 'the pedagogical adjustments required to implement the STEM projects imparting a new instructional paradigm on teachers where their concept of learning progression evolved from teaching maths first, using that acquired in science, followed by application in technology, to a more integrative view where interdisciplinary interactions occur in a more natural way (Thibaut et al., 2018).

In China, (p.247) we learn how the Ministry of Education has implemented various educational reform strategies, including practical STEM activity. The scale of the 'China STEM Education 2029 Innovation Action Plan' launched in May of 2018, opens the systematic development of STEM education in China. This is enviable. It will undoubtedly provide useful experience with which to compare practise elsewhere. Although unconnected, since 2014, the D&T Association has been involved in supporting the Ministry of Education's development of design and technology in Shanghai schools, so is very familiar with the interest in and rapid development of design and STEM in parts of China.

Not only is each description supported by an example, but each study includes a section on the future development of STEM education in secondary schools again making for useful comparisons with what could be developed in a teacher's home country, region or individual school.

The final chapter builds on the examples of STEM education illustrated in chapter 11. It is divided into three sections 'Big issues and STEM education', 'STEM education and disruptive technologies' and the final part, 'Your vision' which considers four possible scenarios for the future of STEM. The latter depicts four scenarios from 'axis of uncertainty' described by two crossing continuums: one being isolation/collaboration, the other vocational/general. The authors claim these 'provide an opportunity to explore possible futures from various perspectives and consider the consequences of such futures for STEM education'. At a time when there is a need for design and technology education to consider its own future and the value of its unique contribution to the broader curriculum, this serves as a timely reminder of the dangers of being reduced in some schools, to a subject taught 'in

isolation, with vocational education intent'. Not a scenario advocates of D&T would welcome.

References

Thibaut, L., Ceuppens, S., De Loof, H., De Meester, J., Goovaerts, L., Struyf, A., Boeve-De Pauw, J., Dehaene, W., Deprez, J., De Cock, M., Hellinckx, L., Knipprath, H., Langie, G., Struyven,

K., Van de Velde, D., Van Petegem, P., & Depaepe, F. (2018) Integrated STEM education: Conceptualizing an instructional approach for secondary education. *European Journal of STEM Education*, 3(1), 02. <https://doi.org/10.20897/ejsteme/85525>

Appendix 2 – Open University Observation form

Part A

Student teacher:	PI number:
Class:	Date:
Observer:	School:
Agreed observation focus (including standards area or individual standards as appropriate)	

Time	Observation notes

Part B Comments arising from observation

Professional attributes											
Q1	Q2	Q3	Q4	Q5	Q6	Q7	Q8	Q9			
Professional knowledge and understanding											
Q10	Q11	Q12	Q13	Q14	Q15	Q16	Q17	Q18	Q19	Q20	Q21
Professional skills											
Q22	Q23	Q24	Q25	Q26	Q27	Q28	Q29	Q30	Q31	Q32	Q33
Overall comment											

Signature of observer:	Date:
-------------------------------	--------------

Appendix 3: TIME SAMPLING TEACHER BEHAVIOUR DURING THE LESSON –
BANGLADESH

Record with a tick (✓) what the teacher is doing at these precise times. <u>SELECT ONLY ONE BEHAVIOUR AT A TIME</u>						
Classroom behaviour: What the teacher is doing.		10 th minute	15 th minute	20 th minute	25 th minute	30 th minute
1	Talking about random topics related to the subject but not the lesson for that day					
2	Reading from the text book					
3	Reading from lecture notes					
4	Silently writing notes on blackboard for students to copy					
5	Using teaching aids (e.g. posters, pictures, real objects, ICT devices)					
6	Giving instructions for student activities, e.g. organising pair work or group work					
7	Supporting students as they use learning aids (e.g. posters, pictures, real					

	objects, ICT devices)					
8	Asking closed questions (e.g. they may be answered directly from the text book)					
9	Asking open questions that require creative thought (i.e. no text book answer)					
10	Giving feedback to students on their work					
11	Listening to students' ideas					
12	Moving around the classroom monitoring and facilitating group work					
13	Moving around the classroom monitoring and facilitating students as they work individually					
14	Listening to students as they read aloud from the textbook					
15	Watching the class (from desk) as they					

	complete exercises					
16	Teaching from the blackboard, e.g. drawing a diagram or making notes on the board to support explanation of a concept or topic					
17	Encouraging individual students or group to speak English in classroom activities					
18	Allowing time (silence) for students to respond to the teacher's questions					
19	Integrating the language skills (listening, speaking, reading and writing)					
20	Explaining something in English					
21	Explaining something in Bangla					
22	Focusing on one side of the classroom (e.g. boys or girls only) during the lesson					

23	Asking questions to only a particular row of students					
24	Other activity (please specify below)					

Note: Activity 16 is different from 4. In 16, the teacher is explaining an idea while the students listen, whereas in 4 the teacher is silently writing notes for student to copy