

University of Groningen

Tailor-made functionalized self-assembled peptide (nano)fibers and hydrogels, and methods, uses and kits related thereto

Maric, Ivana; Otto, Sijbren; Pappas, Charalampos

IMPORTANT NOTE: You are advised to consult the publisher's version (publisher's PDF) if you wish to cite from it. Please check the document version below.

Document Version

Publisher's PDF, also known as Version of record

Publication date:

2022

[Link to publication in University of Groningen/UMCG research database](#)

Citation for published version (APA):

Maric, I., Otto, S., & Pappas, C. (2022). Tailor-made functionalized self-assembled peptide (nano)fibers and hydrogels, and methods, uses and kits related thereto. (Patent No. WO2022211624).

Copyright

Other than for strictly personal use, it is not permitted to download or to forward/distribute the text or part of it without the consent of the author(s) and/or copyright holder(s), unless the work is under an open content license (like Creative Commons).

The publication may also be distributed here under the terms of Article 25fa of the Dutch Copyright Act, indicated by the "Taverne" license. More information can be found on the University of Groningen website: <https://www.rug.nl/library/open-access/self-archiving-pure/taverne-amendment>.

Take-down policy

If you believe that this document breaches copyright please contact us providing details, and we will remove access to the work immediately and investigate your claim.

Downloaded from the University of Groningen/UMCG research database (Pure): <http://www.rug.nl/research/portal>. For technical reasons the number of authors shown on this cover page is limited to 10 maximum.

(12) INTERNATIONAL APPLICATION PUBLISHED UNDER THE PATENT COOPERATION TREATY (PCT)

(19) World Intellectual Property
Organization

International Bureau

(43) International Publication Date
06 October 2022 (06.10.2022)



(10) International Publication Number
WO 2022/211624 A1

(51) International Patent Classification:

C07K 5/00 (2006.01) A61L 27/52 (2006.01)
A61K 38/00 (2006.01)

(21) International Application Number:

PCT/NL2022/050173

(22) International Filing Date:

30 March 2022 (30.03.2022)

(25) Filing Language:

English

(26) Publication Language:

English

(30) Priority Data:

21386023.2 30 March 2021 (30.03.2021) EP

(71) Applicant: **RIJKSUNIVERSITEIT GRONINGEN**
[NL/NL]; Broerstraat 5, 9712 CP Groningen (NL).

(72) Inventors: **MARIC, Ivana**; University of Groningen, Stratingh Institute Centre for Systems Chemistry, Nijenborgh 4, 9747 AG Groningen (NL). **OTTO, Sijbren**; University of Groningen, Stratingh Institute Centre for Systems Chemistry, Nijenborgh 4, 9747 AG Groningen (NL). **PAP-PAS, Charalampos**; University of Groningen, Stratingh Institute Centre for Systems Chemistry, Nijenborgh 4, 9747 AG Groningen (NL).

(74) Agent: **WITMANS, H.A.**; V.O., P.O. Box 87930, 2508 DH Den Haag (NL).

(81) Designated States (unless otherwise indicated, for every kind of national protection available): AE, AG, AL, AM, AO, AT, AU, AZ, BA, BB, BG, BH, BN, BR, BW, BY, BZ, CA, CH, CL, CN, CO, CR, CU, CZ, DE, DJ, DK, DM, DO, DZ, EC, EE, EG, ES, FI, GB, GD, GE, GH, GM, GT, HN, HR, HU, ID, IL, IN, IR, IS, IT, JM, JO, JP, KE, KG, KH, KN, KP, KR, KW, KZ, LA, LC, LK, LR, LS, LU, LY, MA, MD, ME, MG, MK, MN, MW, MX, MY, MZ, NA, NG, NI, NO, NZ, OM, PA, PE, PG, PH, PL, PT, QA, RO, RS, RU, RW, SA, SC, SD, SE, SG, SK, SL, ST, SV, SY, TH, TJ, TM, TN, TR, TT, TZ, UA, UG, US, UZ, VC, VN, WS, ZA, ZM, ZW.

(84) Designated States (unless otherwise indicated, for every kind of regional protection available): ARIPO (BW, GH, GM, KE, LR, LS, MW, MZ, NA, RW, SD, SL, ST, SZ, TZ,

UG, ZM, ZW), Eurasian (AM, AZ, BY, KG, KZ, RU, TJ, TM), European (AL, AT, BE, BG, CH, CY, CZ, DE, DK, EE, ES, FI, FR, GB, GR, HR, HU, IE, IS, IT, LT, LU, LV, MC, MK, MT, NL, NO, PL, PT, RO, RS, SE, SI, SK, SM, TR), OAPI (BF, BJ, CF, CG, CI, CM, GA, GN, GQ, GW, KM, ML, MR, NE, SN, TD, TG).

Published:

- with international search report (Art. 21(3))
- before the expiration of the time limit for amending the claims and to be republished in the event of receipt of amendments (Rule 48.2(h))

(54) Title: TAILOR-MADE FUNCTIONALIZED SELF-ASSEMBLED PEPTIDE (NANO)FIBERS AND HYDROGELS, AND METHODS, USES AND KITS RELATED THERETO

(57) Abstract: The invention relates to self-assembling peptide (nano)fibers, hydrogels, and methods, uses and intermediate products and kits relating thereto. Provided is a method for providing peptide-based functionally modified (nano)fibers, comprising (i) providing a fiber forming solution comprising pseudopeptide building blocks of the formula A-Peptide-B, wherein: Peptide is a moiety of 1 to 8 amino acid residues having a sequence that is predisposed to form a one-dimensional array, such as β -sheet fibrils; A is an aromatic moiety carrying two reactive thiol groups; and B is a reactive α -nucleophile; (ii) exposing the fiber forming solution to oxidizing conditions to induce supramolecular self-assembly of the pseudopeptide building blocks into peptide-based (nano)fibers; and (iii) contacting said (nano)fibers with at least one biologically relevant functional group of interest comprising reactivity C forming a reactive pair with B to obtain covalently functionally modified nanofibers.



WO 2022/211624 A1

Title: Tailor-made functionalized self-assembled peptide (nano)fibers and hydrogels, and methods, uses and kits related thereto.

5

The invention relates to the fields of material science and tissue engineering. More specifically, it relates to functionalized self-assembling peptide fibrillar hydrogels, and methods, uses, intermediate products and kits relating thereto.

10

Currently, the field of material science relies on a strategy that involves understanding and mimicking of structures and behaviors found in nature, to provide solutions in areas ranging from medicine and energy to environmental sustainability. In particular, synthetic biomaterials are being explored at a rapid pace, as they may have suitable properties to be used as extracellular matrices for tissue engineering.[1] Functional supramolecular polymers have been viewed as a powerful platform for such application, since they can be constructed from short peptides[2] or peptide-amphiphiles,[3] containing binding sites for biologically functional ligands.[4] Cell adhesion motifs,[5] peptide sequences that can direct cell differentiation[6] and susceptibility to degradation[7] are important ingredients for successful 3D cell growth within synthetic materials.[8] Synthetic biomaterials are advantageous regarding batch-to-batch consistency, enabling the translation of basic research into clinical applications.[9,10]

25

At the same time, Dynamic covalent chemistry (DCC) has been recognized as a tool to study fundamental questions of living systems,[11] but also to access emergent behaviors of functional materials. For example, self-healing,[12] shape memory, and stimuli-induced stiffness changes are properties that can be achieved by the implementation of reversible bonds into dynamic hydrogels.[13] However, the combination of multiple dynamic orthogonal chemistries has made its way into functional materials only recently, and exciting examples have started to emerge.[12,14]

30

However, current synthetic hydrogels and their functionalization face a number of practical limitations. For example, a highly specific ligand-functionalized material is typically required in order to promote proliferation of a particular type of cells or differentiation of stem cells. This means that, for each specific outcome, a specific material and corresponding 'building blocks' must be developed. Previously reported approaches do not offer a single and simple methodology for a high diverse set of application.

For example, the hydrogel material developed by the group of Stupp (*Science* 303, 1352 (2004); US2005/0272662) involves the synthesis of a large set of self-assembling charged peptide-amphiphiles comprising three segments: an alkyl tail, a structural peptide and a functional peptide. To obtain a functionalized gel capable of generating a specific type of cell response or behaviour, each peptide-amphiphile building block must be provided with a specific functional peptide, like a biologically relevant signal portion. This approach is cumbersome and time-consuming, and limits a widespread practical applications in the field of tissue engineering.

Therefore, the present inventors set out to provide a novel type of hydrogel that can undergo a fast triggered gelation and is cytocompatible. Ideally, they aimed at an approach that allows for "on-demand" chemical customization of fibrillar scaffold, thereby offering the potential for the application as bioactive platform that can dictate and/or stimulate cell fate processes.

These goals were met by the development of a novel system that uses two dynamic covalent bonds in tandem (e.g. disulfides and hydrazones), for the formation of hydrogels containing biologically relevant ligands. The system is based on the DCC mediated self-assembly of pseudo-peptide based building blocks into a one-dimensional array to yield supramolecular fibers, followed by the post-assembly surface decoration of the fibers with one or more (biologically active) compound(s) of interest. The subsequent addition

of a cross-linker can trigger the formation of a hydrogel, which is not only biocompatible but also supports cell morphology.

Thus, the present invention encompasses the discovery that it is possible to
5 modify self-assembled (nano)fibers by incorporating one or more biological signal(s) that do not participate in gel formation, while still permitting hydrogelation by covalent cross-linking of the modified fibers.

For example, in case of the first DCC reaction involving disulfides and
10 hydrazones, the reversibility of the disulfide bonds allows for fiber formation upon oxidation of a dithiol peptide-based building block, while a second reaction, which is in essence also DCC reaction, between the hydrazide-functionalized peptide and an aldehyde cross-linker results in a gel. The same acyl-hydrazone bond-forming reaction is advantageously exploited for
15 the “decoration” of supramolecular nanofiber assemblies, e.g. by cell-adhesion promoting sequences (RGD and LDV) or peptides promoting cell proliferation and/or cell differentiation (e.g. IPP), which functionalized nanofibers are subsequently able to undergo hydrogelation by cross-linking. This modular approach allows the molecular engineering of tailor-made
20 material on demand. Moreover, it is suitably used to incorporate different ligands at the same time, for example using a first molecule that promotes cell adhesion and a second molecule that promotes cell differentiation.

Accordingly, the invention provides a method for providing peptide-based
25 functionally modified fibers, comprising the steps of :

(i) providing a fiber forming solution comprising pseudopeptide building blocks of the formula A-Peptide-B, wherein:

Peptide is a moiety of 1 to 8, preferably 3 to 5, amino acid residue(s) and having a sequence that is predisposed to form a one-
30 dimensional array;

A is an aromatic moiety carrying two reactive thiol groups;

B is a reactive α -nucleophile;

(ii) exposing the fiber forming solution containing the pseudopeptide building blocks to oxidizing conditions to induce supramolecular self-assembly of the pseudopeptide building blocks into peptide-based fibers; and
5 (iii) contacting said nanofibers with at least one functional group of interest comprising reactivity C capable of reacting (i.e. forming reactive pair) with B to obtain covalently functionally modified fibers.

The concept underlying the present invention is not known or suggested in the art. US2005/181973 discloses that self-assembling peptides can be
10 modified by incorporating an additional domain that does not self-assemble, while still permitting assembly of the self-assembling portion. Thus, unlike the present invention, the β -sheet forming domains are modified/functionalized with an additional domain prior to self-assembly. The additional domain is for instance a biologically active peptide motif or a
15 target site for an interaction with a biomolecule. Exemplary self-assembling β -sheet forming domains comprise 2 to 4 copies of the tetrapeptide unit RADA.

Thiol-functionalized peptide building blocks and their self-assembly into
20 fibers have been previously disclosed by the Otto group. For example, Malakoutikhah *et al.* (J. Am. Chem. Soc. 2013, 135, 18406-18417) describes the oxidation of peptide-based dithiol building blocks into macrocyclic structures of different ring sizes, and their assembly into long fibrils held together by β -sheet formation between the peptide chains. Exemplified
25 pentapeptide chains contain the sequence Gly-Leu-Lys-Xaa-Lys, with Xaa having a varying degree of hydrophobicity. See also Sadownik *et al.* (Nature Chemistry volume 8, 264–269 (2016)) and the PhD Thesis by Altay, Y. (Novel peptide replicators from dynamic combinatorial libraries. (2019) University of Groningen).

30

Van Duc Nguyen *et al.* (Soft Matter, 2016, 12, 432) relates to cross-linking self-assembled fibers based on the pentapeptide Gly-Leu-Lys-Phe-Lys with a

focus on the effects of filament length and crosslink density on the mechanical properties of filamentous networks. The crosslinker used is the triblock copolymer PSPMA₂₅-PEO₂₃₀-PSPMA₂₅, which links the fibers together due to ionic (i.e. non-covalent) interaction with the positively charged fibers

However, the art is silent about covalent fiber functionalization, let alone that it suggests the covalent decoration of assembled fibers with one or more biologically active (peptide) compounds prior to hydrogel formation.

10

Prestwich *et al.* (J. Contr. Release 53 (1998) 93-103) discloses the formation of hyaluronic acid (HA)-hydrogel and post-modification of the hydrogel with a drug comprising a functional group that reacts with the hydrazide group carried by the hydrogel. This system differs from that of the present invention not only in the non-peptidic nature of the gel, but also in the fact that in Prestwich the hydrogels are modified after they have been prepared. In contrast, according to the present invention self-assembled peptide-based nanofibers are modified prior to the formation of a hydrogel.

20 The present invention is centered around a pseudopeptide building block represented by an amino-acid based moiety herein referred to as "Peptide", which consists of a few (1- 8) amino acids, Peptide being functionalized, preferably at its N-terminus, with reactivity A, i.e. an aromatic moiety carrying two reactive thiol (-SH) groups. Group A is capable of undergoing reversible thiol-disulfide exchange allowing for the formation of macrocyclic structures via dynamic covalent bond formation between thiol groups of A moieties of other A-Peptide-B (or A-Peptide; see below) building blocks. The thiol-groups can be attached directly to a carbon atom of the aromatic moiety, or they can be attached via an aliphatic chain, for example a C₁-C₄ linear alkyl. Preferably, the thiol-groups are attached directly to a carbon atom of the aromatic moiety.

30

The aromatic moiety is preferably a dithiol-substituted 5- or 6-membered aromatic moiety. The relative position of the thiol-substituents should allow for the formation of macrocyclic structures of A-moieties of a plurality of pseudo-peptide building blocks. In one aspect, it is a 1,3- dithiol-benzene ring, preferably with the peptide moiety attached at the 5-position.
5
In addition to the two thiol groups, the aromatic ring may contain one or more further substituents that do not interfere with macrocyclic ring formation. Suitable substituents include C₁-C₃ alkyls, such as -CH₃, and halogens, such as -Cl or -F. The further substituent(s) is for example
10 positioned at the 2- and/or 4- position of a 1,3- dithiol-benzene ring. In a specific aspect, A is 1,3-dithiol-2-methyl-benzene, 1,3-dithiol-2-ethyl-benzene, 1,3-dithiol-2-chloro-benzene, 1,3-dithiol-2-fluoro-benzene, 1,3-dithiol-2,4-dimethyl-benzene, 1,3-dithiol-2,4-diethyl-benzene, 1,3-dithiol-2,4-dichloro-benzene, or 1,3-dithiol-2, 4-difluoro-benzene. In another aspect, the
15 aromatic moiety is only substituted with two thiol groups.

Pseudopeptide building block A-Peptide-B is furthermore characterized in the Peptide moiety being functionalized with reactivity or group B, which B reactivity is compatible with, and can form a covalent bond, with both
20 reactivity C (present on the compound of interest) and reactivities D (present on the cross-linking agent; see further herein below). Herewith, the fibrils resulting from pseudo-peptide self-assembly can not only be covalently functionalized with one or more compounds of interest, but they can also be triggered to undergo hydrogelation by covalent cross-linking.
25 The B reactivity can be present at the C-terminus of Peptide, or it can be attached to one or more amino acid side chains. Good results are obtained when the B reactivity is present at the C-terminus of Peptide, preferably in combination with group A being attached at the N-terminus.

30 According to the invention, B is a reactive α -nucleophile, also known in the art as " α -effect nucleophile". The alpha effect refers to the increased nucleophilicity of an atom due to the presence of an adjacent (alpha) atom

with lone pair electrons. This first atom does not necessarily exhibit increased basicity compared with a similar atom without an adjacent electron donating atom.

5 It will be appreciated by a person skilled in the art that this approach requires a careful selection of the suitable B-C and B-D chemistries. The reaction between the B-C reactive pair and the B-D reactive pair should be compatible with disulfide chemistry. This means that they are orthogonal, i.e. that they do not interfere with each other and they are performed
10 independently. Also, each of the B, C and D reactivities must be biocompatible. The B functionality facilitates hydrogelation and must allow for bio-orthogonal bond formation between the fiber-like supramolecular structure and the cross-linker reversible covalent chemistries.

15 For example, a method of the invention relies on the disulfide/hydrazone combination or the disulfide/oxime combination. The reactions that form oxime and hydrazone bonds are among the oldest, most intensively studied bioconjugation reactions. Bioconjugation reactions must be compatible with the biomolecules upon which they act. Hydrazone and oxime bond-forming
20 reactions are biocompatible. They are also versatile, leading to the formation of widely diverse products, with usually rapid reaction rates. In oxime and hydrazone bond-forming reactions, an aldehyde or ketone reacts readily with a nucleophilic alkoxyamine (also known as aminoxy or oxyamine) or hydrazine, to yield an oxime or hydrazone, respectively. These
25 reactions are chemoselective. Water forms as a byproduct of the reaction. In general, aldehydes react more rapidly than ketones.

In one embodiment, a method of the invention relies on the disulfide/hydrazone combination. Herein, the B reactivity is or comprises a
30 hydrazine (-NH-NH₂) group and the C and D reactivities contain a carbonyl. The resultant reaction leading to a hydrazine bond involves R-NH-NH₂ + R'(CO)R" -> R-NH-N=CR'R". In a preferred embodiment, B is or comprises a

hydrazine (-NH-NH₂) group and reactivity C is an aldehyde or glyoxylyl group and/or reactivity D is an aldehyde group.

In another embodiment, a method of the invention relies on the
5 disulfide/oxime combination. Herein, the B reactivity is or comprises a
alkoxy-amine (-O-NH₂) group and the C and D reactivities contain a
carbonyl. The resultant reaction involves $R-O-NH_2 + R'(CO)R'' \rightarrow R-O-$
 $N=CR'R''$. For example, B is or comprises a -O-NH₂ group and reactivity C is
an aldehyde or glyoxylyl group and/or reactivity D is an aldehyde group.
10 The -NH-NH₂ or -O-NH₂ group is readily attached to the Peptide, either at
the C-terminus or an amino acid side chain. For example, hydrazides of
aspartic and glutamic acid can be prepared from corresponding Fmoc-
protected amino acid anhydrides (Barnes et al. Chem. Commun., 2021,57,
1006-1009). As another example, non-natural amino acids that are
15 synthetically accessible can be used (see WO2007/079130). In one
embodiment, 2-amino-3-(4-(hydrazineylmethyl)phenyl)propanoic acid,
2-amino-3-(4-(hydrazineylmethoxy)phenyl)propanoic acid, or
2-amino-3-(4-(aminoglycyl)phenyl)propanoic acid is used.
20 In a preferred embodiment, -NH-NH₂ or -O-NH₂ group is attached to the
Peptide's C-terminus. For example, the pseudo-peptide building block is of
the formula I, II, III or IV herein below.

25

Formula I

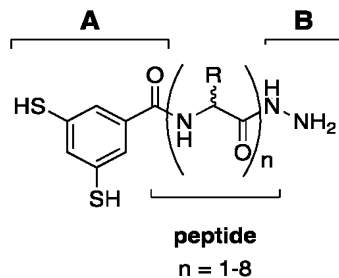

Formula II

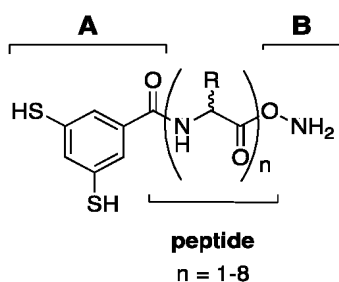
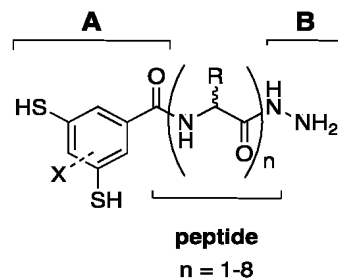

Formula III

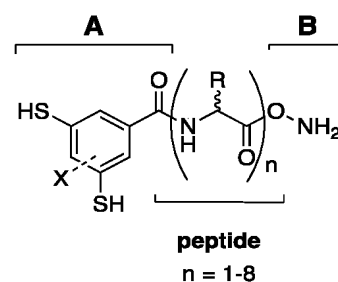

Formula IV

- 5 Indicated are the A and B reactivities, and the Peptide moiety comprising n amino acids. Preferably, n is 2-8, more preferably 2-6. R is any natural or non-natural amino acid side chain, which can be attached in the D- or L-configuration. Optional substituent X is halogen or C₁-C₃-alkyl. Preferably, X is fluorine (F) or methyl (CH₃). If present, X is preferably at the para-
- 10 position.

The A and B moieties can be attached by methods known in the art. For example, a dithiol substituted aromatic core is suitably synthesized using procedures adapted from: J. M. A. Carnall *et al.* (Science 2010, 327, 1502–1506), S. Otto *et al.* (Science 2002, 297, 590-593) and L. Field & P. R. Engelhardt (J. Org. Chem. 1970, 35, 3647-3655). A carboxylic substituent on

15 the dithiol core can be reacted with the N-terminus of peptide in the last step of solid phase peptide synthesis (SPPS). The B moiety can be introduced via hydrazinolysis of Peptidyl-Wang-TentaGel resins (C. Bello *et al.*, J. Pept. Sci. 2015, 3, 201-207).

Whereas the B reactivities of the building blocks allow for post-assembly functional modification of the nanofibers and subsequent hydrogelation, it is not necessary that all peptide-derived building blocks contain a reactive group B. In fact, the use of a mixture of building blocks of (i) B-containing building blocks of the formula A-Peptide-B and (ii) building blocks of the formula A-Peptide can be advantageous e.g. it allows to fine tune the properties of the resulting functionalized hydrogel. Accordingly, in one embodiment the fiber forming solution further comprises pseudopeptide building blocks of the formula A-Peptide, wherein A and Peptide are as defined herein above. In one aspect, the fiber forming solution comprises a mixture of A-Peptide-B and A-Peptide building blocks in a molar ration of 4:1 to 1:4, e.g. 3:1 to 1:3, 3:1 to 1:1, 2:1 to 1:1, 1:1, 1:1 to 1:2 or 1:1 to 1:3. In one embodiment, A-Peptide is present in molar excess to A-Peptide-B. In another embodiment, A-Peptide-B is present in a molar excess to A-Peptide. In yet another embodiment, the fiber forming solution contains about equal amounts of A-Peptide and A-Peptide -B pseudopeptide building blocks.

It is preferred that the A-moieties of building blocks A-Peptide-B and A-Peptide within a fiber forming solution are the same. However, the Peptide moiety can be the same, or it can be different.

A method of the present invention relies among others on the intermolecular interaction or "stacking" of peptide motifs contained in the pseudopeptide building blocks to form a one-dimensional array, thereby allowing for the formation of fibers. In other words, the peptide-based building blocks, after reacting into disulfides, are capable of assembling together under suitable conditions as a stable supra-molecular structure. In one aspect, the fibers are of nanometric dimensions and referred herein as nanofibers. The term "nanofibers" is well known in the art, and refers to fibres that have a mean diameter of the order of several nanometers, e.g. tens of nanometers, to several hundreds of nanometers.

Peptides can assemble into complex nanostructures through highly specific biomolecular interactions such as hydrogen bonding and hydrophobic interaction. For example, Peptide is a peptide moiety having a sequence that is predisposed to form β -sheet fibrils.

5 The beta sheet, (β -sheet) (also β -pleated sheet) is a common motif of the regular protein secondary structure. Beta sheets consist of beta strands (β -strands) connected laterally by at least two or three backbone hydrogen bonds, forming a generally twisted, pleated sheet. Beta-sheet fibrils are highly consistent in their morphology, even when
10 constructed from unrelated peptides or proteins. The fact that there exist so many peptides of varying sequences, lengths, and patterning of polar and nonpolar residues that form β -sheet fibrils suggests that β -sheet assemblies can tolerate a variety of appended sequences or other modifications. In many but not all cases, β -strand formation occurs when hydrophilic and
15 hydrophobic peptide side chains are positioned on opposite sides of a peptide backbone. Accordingly, in one embodiment of the invention the pseudopeptide building block contains a peptide moiety or peptide chain comprising or consisting of alternating hydrophobic and hydrophilic amino acid residues.

20 Hydrogen bonding between individual strands promotes association into intermolecular β -sheets that contain both a hydrophilic and a hydrophobic face. In β -sheets, the backbone N–H and C=O of one strand hydrogen bond with the C=O and N–H of an adjacent strand, respectively, and the side chains project alternatively above and below the plane of the
25 sheet. Although this hydrogen bonding pattern between peptide backbones is the defining characteristic of β -sheets, the structure is also reinforced by hydrophobic interactions, van der Waals forces, and electrostatic interactions that occur between the side chains and between the side chains and backbone. Most sheets also have a twist of 0–30° between consecutive
30 strands.

It is also known that certain patterns of polar and nonpolar amino acids favor the formation of β -sheet structures. Peptides with strictly

alternating polar and nonpolar residues, for example, can produce β -sheet fibrils, and many such peptides have been utilized in the construction of self-assembling biomaterials. However, many β -sheet fibrillizing peptide sequences that do not strictly adhere to the alternating polar/nonpolar design have been described. In a β -sheet with alternating polar/nonpolar sequences, all hydrophobic residues are placed on one side of the sheet, and all hydrophilic residues are placed on the opposite side, providing an amphiphilic surface that drives assembly into tertiary structures such as fibrils. Accordingly, in one embodiment the peptide moiety in a building block of the invention comprises alternating polar and nonpolar residues.

Apart from the repetitive sequence pattern, there are few rules governing the formation of β -strands and sheets, although it is known that amino acids with β -branched side-chains, e.g., Val (V), Thr (T), and Ile (I), are preferred. Furthermore, large aromatic residues (tyrosine, phenylalanine, tryptophan) and β -branched amino acids (threonine, valine, isoleucine) are favored to be found in β -strands in the middle of β -sheets. Further useful peptide sequences include those referred to in the art as "peptide replicators". See for example Dissertation of Yigit Altay (2019), University of Groningen, ISBN 978-94-034-1802-5; Dissertation of Meniz Altay (2019), University of Groningen, ISBN 978-94-034-1804-9; M. Malakoutikhah *et al.* *J. Am. Chem. Soc.* 2013 (doi:10.1021/ja4067805); J.M.A. Carnall *et al.* *Science* 2010 (doi: 10.1126/science.1182767; B. Bartolec *et al.* *Chem. Comm.* 2018 (doi:10.1039/C8CC06253F). Peptides may be synthesized using standard Fmoc chemistry and purified using high pressure liquid chromatography.

Accordingly, in one embodiment the pseudopeptide building block comprises Peptide of the sequence $-(Xaa)_n-$, wherein n is 1 to 8, and wherein Xaa can be any D- or L-amino acid (natural or non-natural) provided that Peptide as a whole allows for fiber formation.

Suitable peptides include those containing at least 2 or 3 amino acid residues. For example, they consist of 2-8, 2-7, 2-6, 2-5, 2-4, 2-3, 3-8, 3-

7, 3-6, 3-5 or 3-4 amino acids. Specific peptides are dipeptides, tripeptides, tetrapeptides, pentapeptides, hexapeptides, heptapeptides and octapeptides. Very good results can be obtained using dipeptides, tripeptides, tetrapeptides, pentapeptides or hexapeptides. However, nanofibers can also
5 be formed with building blocks containing only a single amino acid, e.g. Lys.

It is preferred that Peptide comprises at least one Lys residue. In a specific aspect, Peptide is Lys or contains a Lys residue at the C-terminus. In one embodiment, Peptide is a dipeptide of the formula Xaa1-Xaa2, for example wherein Xaa1 is p-amino-L-Phe and wherein Xaa2 is Lys. In
10 another embodiment, Peptide is a dipeptide of the formula Tyr-Lys or Lys-Tyr.

In another embodiment, Peptide is a tripeptide of the formula Xaa1-Xaa2-Xaa3, for example wherein Xaa1 and Xaa2 are non-polar amino acids and Xaa3 is a positively charged amino acid. In one aspect, Xaa1 is
15 Gly, Ala, Val, Ile or Phe, preferably Gly; Xaa2 is Gly, Leu, Ala, Val, Ile or Phe, preferably Leu; and Xaa3 is Lys, Arg or His, preferably Lys. Very good results are obtained when Xaa2 is Leu and Xaa3 is Lys. In a particularly preferred embodiment, Peptide is or comprises the sequence Gly-Leu-Lys (GLK), Gly-Ser-Lys (GSK), Gly-Ile-Lys (GIK) or Gly-Ala-Lys (GAK).

20 In yet another embodiment, Peptide is a tetrapeptide of the formula Xaa1-Xaa2-Xaa3-Xaa4, for example wherein Xaa1 and Xaa2 are non-polar amino acids, Xaa3 is a positively charged amino acid and Xaa4 is any non-polar, polar or unnatural amino acid residue. Exemplary tetrapeptides include Gly-Leu-Lys- Ser/Phe/Leu.

25 In yet another embodiment, Peptide is a pentapeptide of the formula Xaa1-Xaa2-Xaa3-Xaa4-Xaa5, for example wherein Xaa1 provides flexibility, e.g. Gly, β -Ala or γ -aminobutyric acid (GABA), Xaa2 is a non-polar amino acid, Xaa3 is a positively charged amino acid, Xaa4 is any non-polar, polar or unnatural amino acid residue, and Xaa5 is a positively
30 charged amino acid residue. Exemplary pentapeptides include Gly-Leu-Lys-Phe/Ala-Lys

In a still further embodiment, Peptide is a hexapeptide of the formula Xaa1-Xaa2-Xaa3-Xaa4-Xaa5-Xaa6, for example wherein Xaa1 provides flexibility, e.g. Gly, β -Ala or γ -aminobutyric acid (GABA), Xaa2 is a non-polar amino acid, Xaa3 is a positively charged amino acid, Xaa4 is any non-polar, polar or unnatural amino acid residue, Xaa5 is a positively charged amino acid residue, and Xaa6 is a negatively charged residue, such as Asp or Glu.

Exemplary penta- or hexapeptide sequences for use in the present invention are of the formula Xaa1-Xaa2-Xaa3-Xaa4-Xaa5-Xaa6, wherein

10 Xaa1 is Gly, β -Ala or γ -aminobutyric acid (GABA)
Xaa2 is Ala, Val, Leu, Ile or Phe, preferably Leu
Xaa3 is Lys, Arg or His, preferably Lys
Xaa4 is Ala, Val, Leu, Ile or Phe
Xaa5 is Lys, Arg or His, preferably Lys
15 Xaa6 is Asp, Glu, or absent.

As mentioned herein above, the invention also related to a method for providing peptide-based functionally modified (nano)fibers, comprising the steps of :

20 (i) providing a fiber forming solution comprising a mixture of (a) pseudopeptide building blocks of the formula A-Peptide-B and (b) pseudopeptide building blocks of the formula A-Peptide, wherein:

Peptide is a moiety of 1 to 8, preferably 3 to 5, amino acid residues having a sequence that is predisposed to form a one-dimensional array, such as β -sheet fibrils;

25

A is an aromatic moiety carrying two reactive thiol groups; and

B is a reactive α -nucleophile;

(ii) exposing the fiber forming solution to oxidizing conditions to induce supramolecular self-assembly of the mixture pseudopeptide building blocks into peptide-based (nano)fibers; and

30

(iii) contacting said (nano)fibers with at least one functional group of interest comprising reactivity C forming a reactive pair with B to obtain functionally modified nanofibers.

5 It one embodiment, the Peptide-moieties of building blocks A-Peptide-B and/or A-Peptide within a mixture of building blocks are different with respect to the number of amino acids and/or the nature of the amino acids, provided that the different Peptide moieties allow for the formation of a one-dimensional array. For example, the fiber forming solution comprises a
10 mixture of (i) A-Peptide-B wherein Peptide is (Xaa)_n; and (ii) A-Peptide is wherein Peptide is (Xaa)_m, wherein n and m are individually selected from 1-5, and wherein n and m are the same or distinct. In one aspect, n is 3-4 and m is 1-4. See example 7 herein below for various representative
15 mixtures of pseudopeptide building blocks with and without the B reactive α-nucleophile.

In a method of the invention, step (ii) comprises exposing the fiber forming solution comprising the (mixture of) pseudopeptide building blocks to oxidizing conditions to induce supramolecular self-assembly of the
20 pseudopeptide building blocks into peptide-based fibers. The oxidizing conditions allow for group A to undergo reversible thiol-disulfide exchange, resulting in the formation of macrocyclic structures via dynamic covalent bond formation. Furthermore, the conditions facilitate, or at least do not interfere with, intermolecular interactions between the peptide moieties of
25 the building blocks.

Suitable oxidizing conditions may involve one or more of the following:

- 1) exposure to air (slow oxidation) or Na-perborate (fast oxidation);
- 2) pH between 8 and 8.5 to have thiols deprotonated so they can attack
30 disulfides and promote exchange;
- 3) temperature between room temperature to about 45°C. An increase in temperature can alter the kinetic of assembly formation.

4) aqueous conditions, such as a borate buffer. High concentration of salt can cause unwanted precipitation of assemblies/precursors or fiber aggregation.

- 5 In one embodiment, peptide building blocks are dissolved to a concentration of about 2-10 mM, e.g. 4-6 mM, in an aqueous borate buffer in the range pH 8-8.5, followed by oxidation using perborate, for example a 20-60 mM sodium perborate solution.

Because remaining B groups ought to participate in subsequent hydrogelation, only partial covalent modification of the B groups is desired. For example, if it is intended to modify 10% of B moieties with biologically relevant ligand functionalized with C, it can be calculated what is the 10% of total number of moles of A-peptide-B. Since B and C react in a 1 to 1 stoichiometry, this means that a remaining 90% of free moiety B is available for subsequent hydrogelation. The degree of modification is readily monitored, e.g. by UPLC.

(Nano)fiber formation may involve the self-assembly of one type of pseudopeptide building blocks, or a mixture of two or more types of pseudopeptide building blocks, differing for example in the Peptide sequence, the dithiol-aromatic core A, and/or reactivity B. Also, reactivity B may be absent in some of the building blocks. In case the same building blocks are used, self-assembly results in homogenous (nano)fibers. In case different building blocks are used, self-assembly results in heterogenous (nano)fibers. For example, it has been reported that in mixed systems, in which peptide 1 is already assembled into short fibers, peptide 2 can assemble on top and bottom of the first assembly to result in triblock fibrous copolymers (Pal *et al.* *Angewandte Chemie* (2015), Vol. 54, Issue 27, 7852-7856).

30 In one embodiment, a Formula I or II building block is used for A-Peptide-B, preferably Formula I. In another embodiment, a Formula III or IV building block is used, preferably Formula III.

In yet another embodiment, a combination of two or more building blocks A-Peptide-B according to Formula I, II, III or IV is used, for example a mixture comprising Formula I and II, Formula I and III, Formula II and III; or Formula II and IV building blocks is used.

- 5 These embodiments may be combined in a mixed system comprising A-Peptide building blocks.

Following self-assembly, the (nano)fibers are “decorated” or functionalized with one or more (bioactive; biologically relevant) compounds of interest. To
10 that end, step (iii) of a method of the invention comprises contacting the assembled (nano)fibers with at least one functional group of interest comprising reactivity C capable of reacting with B (i.e. B and C form a reactive pair) to obtain functionally modified nanofibers. Thus, reactivity C is selected on the basis of the chemical nature of group B. For example, in
15 case B is or comprises a hydrazine (-NH-NH₂) or an alkoxy-amine (-O-NH₂) group, the C reactivity suitably comprises a carbonyl moiety to allow for covalent nanofiber functionalization via, respectively, a hydrazine or an oxime bond. In one embodiment, reactivity C is or comprises an aldehyde or glyoxylyl group. In a specific embodiment, reactivity C is a 4-formylbenzoyl
20 group.

A person skilled in the art will understand and appreciate that a “biologically relevant functional group of interest” refers to any molecule, ligand, substance or moiety that is (suspected to be) of use in cell or tissue
25 engineering, e.g. in preparing a cell responsive hydrogel. It can be a proteinaceous or non-proteinaceous substance. It can be any substance capable of directing, supporting or enhancing cell fate, development, morphology, growth or differentiation.

30 Since a method of the invention involves post-assembly modification it is advantageously used to functionally modify the nanofibers with two or more different functional groups of interest. Accordingly, in one aspect step (iii)

comprises contacting said nanofibers with two or more different biologically relevant functional groups of interest, either sequentially or simultaneously i.e. using a mixture of two or more different functional groups of interest in a predetermined ratio. This approach is especially attractive in studies
5 involving the optimization of one or more cell responses in the presence of a functionalized hydrogel.

Exemplary proteinaceous functional groups of interest comprise biologically active peptide motifs that are well known in the art, e.g., a peptide motif
10 found in a naturally occurring protein, or a target site for an interaction with a biomolecule. In certain embodiments of the invention the naturally occurring protein is a component of the extracellular matrix (ECM), e.g., a component of the basement membrane.

Preferably, the peptide of interest is selected from the group
15 consisting of growth factors, differentiation factors, cytokines, chemokines, cell adhesion ligands and protease cleavage sites. For example, the peptide of interest is or comprises a protease-degradation site, such as a substrate for matrix metalloproteinases (MMPs).

In another specific aspect, the biologically relevant peptide of
20 interest comprises or consists of an oligopeptide. For example, the oligopeptide has the amino acid sequence RGD or LDV. These motifs are often employed peptides for stimulated cell adhesion on synthetic surfaces. RGD has been introduced into synthetic biopolymers formed by blending, copolymerization, chemical or physical treatment, as stable covalent linking of
25 the bioactive signal is a prerequisite for promoting cell spreading. The LDV motif has been applied for its cell adhesive properties, in chemical systems that can inhibit tumor metastasis and soft materials for T-cell activation. As another example, the biologically relevant group of interest is a peptide having an effect on osteoblasts, for instance the tripeptide Ile-Pro-Pro.

30

In a specific aspect, step (iii) of a method of the invention comprises contacting assembled (nano)fibers comprising -NH-NH₂ and/or -O-NH₂

groups with at least one functional ligand comprising an aldehyde or glyoxylyl-reactivity.

It was found that post-modified fibers remained stable over a period of at least several weeks, and that they can be triggered to undergo rapid hydrogelation upon an external trigger. A further aspect of the invention therefore relates to a method for providing a peptide-based functionalized hydrogel. Hydrogels are in principle three-dimensional (3D) polymeric networks that are filled with water. The water content reaches as high as 90%–99% while it depends on the polymer concentration. This fact explains high hydrophilicity of hydrogels and the ability to safely incorporate biological entities (proteins and cells) without an aggregation. The mechanical behavior of hydrogels is typically viscoelastic which is associated with the water and the movement of polymer networks in fluid.

A method of the invention for providing a peptide-based functionalized hydrogel comprises providing functionally modified peptide-based (nano)fibers according to a method as described herein above, followed by adding a crosslinker comprising a plurality of reactive groups D capable of reacting with B to induce hydrogelation of the functionally modified (nano)fibers. As explained previously, any type of chemistry can be used for the B and D moieties, provided that the cross-linker comprises functionalities complementary to the B groups. Moreover, the conditions required or applied for covalent bond formation between B and D should be compatible, e.g. sufficiently mild, with peptide-based nanofibers. For example, a fiber solution is prepared as above mentioned at a 0.5 to 10 mM concentration (total of A-Peptide-B and A-Peptide units). Cross-linking may involve adding corresponding amount of cross-linker dissolved in a suitable solvent, such as acetone. Preferably, the relative amount/concentration of assembled fibers and the amount/concentration of cross-linker are chosen such that the molar ratio of complementary (remaining) reactivities B and D are about equal.

In one aspect, reactive group D comprises a carbonyl-
functionality, preferably an aldehyde. For example, suitable crosslinkers
comprising a plurality of D reactivities include di- and trialdehydes. In a
specific aspect, the cross-linker is selected from the group consisting of
5 glutaraldehyde, 2,5-thiophenedicarboxaldehyde, terephthaldehyde,
isophthaldehyde, succinaldehyde, substituted versions of benzene-1,3 and
1,4 bis-carboxaldehydes, and benzene- 1,3,5- tricarboxaldehyde. These cross-
linkers are particularly suitable for preparing a hydrogel from
functionalized (nano)fibers comprising carbonyl groups as B reactivity.

10

As is demonstrated herein below, cells grown on hydrogels prepared from
nanofibers comprising the GLK tripeptide motif displayed extended
morphologies, characteristic for cell spreading and adhesion independent of
the ligand used for its functionalization. Herewith, GLK-containing building
15 blocks are advantageously used for (nano)fiber assembly and subsequent
hydrogelation. The invention therefore also relates to a method for providing
an ECM-mimicking/cell adhesive peptide-based hydrogel, comprising the
steps of:

(i) providing pseudopeptide building blocks of the formula
20 A-Peptide-B, wherein "Peptide" is a peptide moiety of 3 to 8, preferably 3 to
6, amino acid residues comprising or consisting of the sequence GLK, A is
an aromatic moiety carrying two reactive thiol groups, and B is a reactive α -
nucleophile;

(ii) exposing the pseudopeptide building blocks to oxidizing
25 conditions to induce supramolecular self-assembly of the pseudopeptide
building blocks into peptide-based (nano)fibers; and adding a crosslinker
comprising a plurality of reactive groups D capable of reacting with B to
induce hydrogelation of the (nano)fibers into an ECM-mimicking hydrogel.
Prior to hydrogelation, the assembled fibers may be functionally modified
30 with one or more groups of interest, e.g. with further adhesive ligands
and/or bioactive signals, as described herein above.

The present invention discloses materials characterized by several properties that potentially make this system a tunable, bioactive scaffold that can stimulate cell fate processes. First, similarly to the extracellular matrix (ECM), the synthetic material possesses a fibrous structure, as it is prepared from one-dimensional assemblies of molecular stacking motifs. Second, the B functionality on the building blocks facilitates hydrogelation between a fiber-like supramolecular polymer and a suitable cross-linker having functionalities D. The same reaction can allow attachment of C-functionalized biologically relevant ligand(s), such as cells adhesion motifs (e.g., RGD, LDV) or short peptide sequences known to direct differentiation of cells, e.g. osteoblasts or stem cells. Third, due to its peptide nature, the material has an excellent cytocompatibility. The invention therefore also relates to the products obtainable or obtained by a method herein disclosed. In one embodiment, it provides peptide-based functionally modified (nano)fibers obtainable by the "post-assembly modification" method. In a further embodiment, it provides a peptide-based functionalized hydrogel obtainable by a method of the invention.

Further aspects of the invention relate to various uses, methods, compositions and applications of peptide-based functionally modified (nano)fibers and/or a peptide-based functionalized hydrogel as provided herein. Exemplary uses include tissue engineering, scaffold synthesis, cell culturing, cell culture substrates, for drug and gene delivery, as wound dressing, as an implant, as an injectable agent that gels in situ, in pharmaceutical or cosmetic compositions, in regenerative medicine, in tissue engineering and tissue regeneration.

One embodiment relates to a composition comprising (i) peptide-based functionally modified (nano)fibers and/or a peptide-based functionalized hydrogel according to the invention and (ii) cells, preferably mammalian cells. The composition may comprise one or more further components, such as bioactive therapeutic(s) that stimulate regenerative processes and/or

modulate the immune response. Preferred compositions include peptide-based functionalized hydrogel according to the invention and mammalian cells.

5 The invention provides uses of and methods for using peptide-based functionally modified (nano)fibers and/or a peptide-based functionalized hydrogel according to the invention in tissue engineering and tissue regeneration. Disclosed is a method for tissue engineering, comprising contacting cells with a peptide-based functionalized hydrogel. Also disclosed
10 is a method of tissue regeneration comprising the steps:
providing a peptide-based functionalized hydrogel as defined above,
exposing said hydrogel to cells which are to form regenerated tissue,
allowing said cells to grow on said hydrogel. In one embodiment, the method as defined above is performed in-vitro or in-vivo. In one embodiment, the
15 method as defined above is performed in vivo, wherein, a hydrogel is provided at a place in a body where tissue regeneration is intended. In one embodiment, the method comprises injecting said hydrogel at a place in the body where tissue regeneration is intended.

20 A further embodiment relates to a tissue-engineering or biomimetic scaffold, that can support the in vivo and/or in vitro growth of cells and facilitate the regeneration of native tissue. In one aspect, the invention provides tissue-engineering or biomimetic scaffold, comprising:
(a) a microporous scaffold comprising a biocompatible material suitable for
25 use in tissue-engineering scaffolds, wherein said biocompatible material is a biocompatible polymer that comprises a biodegradable polymer; and
(b) a peptide-based functionalized hydrogel according to the invention.

Since the concept underlying the present invention relies on the post-
30 assembly functionalization of peptide-based (nano)fibers, it also provides a kit-of-parts that allows for the “on site” functionalization of a peptide-based fiber assembly by the end user. The kit may provide the pre-assembled

(nano)fibers, or it may provide pseudo-peptide based building blocks for (nano)fiber self-assembly on-site.

Accordingly, the invention provides a kit-of-parts for use in a method of the invention, comprising (i) first container comprising pseudo-peptide building blocks of the formula A-Peptide-B, wherein Peptide
5 consists of 1 to 8, preferably 2 to 8, more preferably 3 to 5, amino acid residues; A is an aromatic moiety carrying two thiol groups capable of undergoing reversible thiol-disulfide exchange; B is a reactive α -nucleophile; and (ii) in a second container one or more functional group(s) of interest
10 comprising reactivity C capable of reacting with B.

Also provided is a kit-of-parts for providing a functionalized hydrogel, comprising (i) peptide-based (nano)fibers comprising moiety B being a reactive α -nucleophile; and (ii) one or more functional group(s) of interest comprising reactivity C capable of reacting with B. Herein, the B
15 and C reactivities are as described herein above. Preferably, the kit comprises two or more distinct biologically relevant groups of interest, such as a growth factor and an adhesion ligand, each carrying the same reactivity C. The kit may further comprise a cross-linking agent having functionalities D.

20 Analogous to what is described herein above in relation to the building blocks, B may comprise or consist of a -NH-NH₂ or -O-NH₂ functionality, preferably B is -NH-NH₂. Reactivity C and D may comprise a carbonyl-functionality, preferably C is an aldehyde or glyoxylyl group and D is an aldehyde. The kit may furthermore comprise pseudo-peptide building blocks
25 of the formula A-Peptide.

LEGEND TO THE FIGURES

Figure 1. a) Mechanism of fiber formation starting from aromatic dithiol functionalized pseudo-peptide building block 1. Molecule 1 undergoes
30 oxidation to form a small dynamic combinatorial library (DCL) consisting of cyclic disulfides in different oligomeric states. Macrocycle 1₅ self stabilizes

by forming short stacks of rings, shifting the exchange pool towards the formation of **15**. Short stacks elongate from both ends, resulting in a supramolecular polymer with a fiber-like structure.

- b) Cartoon representation of the stepwise hydrogelation process. Fast triggered gelation is achieved through the acyl-hydrazone formation by the addition of dialdehyde cross-linker to the fiber solution. Here, for simplicity reasons, only cross-linking with dialdehyde is schematically depicted, while it is expected that cross-linking with trialdehyde is achieved identically. Covalent linking interconnects the fibers into a hydrogel, a 3D network that can contain a large amount of water.
- c) Di- and trialdehydes tested for cross-linking of **15** fibers for hydrogel formation: glutaraldehyde (**2**), aldehyde-PEG-aldehyde, MW 600 (**3**), terephthalaldehyde (**4**), isophthalaldehyde (**5**), quinolone-based dialdehyde (**6**), benzene – 1,3,5 – tricarboxaldehyde (**7**) and triazine-based trialdehyde (**8**).
- d) Hydrogel formation upon the addition of different cross-linkers. Vial inversion test indicates the formation of hydrogels in the presence of di- and trialdehydes containing short and rigid spacer groups between the carbonyls, such as **2**, **4**, **5**, and **7**.

Figure 2 Scanning electron micrographs of a) hydrogel formed upon addition of **2**, b) hydrogel formed upon addition of **4**, c) hydrogel formed upon addition of **5** and d) hydrogel formed upon addition of **7**. The solvent of the hydrogels was removed in vacuo to yield the product as a white powder, which was then spread over a clean silicon wafer for SEM measurement.

Figure 3 i) Gel formation ($V = 300 \mu\text{L}$, $[1] = 4.0 \text{ mM}$) upon addition of terephthalaldehyde; iv) vial inversion test shows undamaged gel in presence of growth medium on day 5; ii) and v) addition of $200 \mu\text{L}$ of growth medium on gel (day 0 and day 5, respectively); iii) and vi) vial inversion test a few minutes after a new portion of the medium has been added (day 0 and day 5, respectively); before adding a new portion of the medium, the previous layer

of the liquid has been removed. The gel exhibits a good stability for at least several months.

Figure 4 a) Representative transmitted light image and b) representative
5 fluorescence microscopy image of human bone marrow-derived
mesenchymal stem cells (hBM-MSCs) on hydrogel-coated glass coverslips in
growth medium, stained with calcein-AM (live cells) and propidium iodide
(dead cells), after 24 h. Scale bars equal to 150 μm . c) Quantification of cell
10 viability cultured on hydrogel-coated glass coverslips in growth medium for
three repetitions of the experiment. Mean \pm SD (n=3, three random image
fields per experiment).

Figure 5 UPLC analyses of dynamic combinatorial libraries (DCLs) made
by oxidation and disulfide exchange of **1** (4.0 mM) in borate buffer (12.5 mM,
15 pH 8.2) stirred at 1200 rpm: a) when dominated by self-assembly **1₅**; b) post-
assembly functionalization of **1₅** by glyoxylyl-RGD (**1₅-RGD**) and c) glyoxylyl-
LDV (**1₅-LDV**), both recorded 30 minutes after addition of the corresponding
aldehydes. Formed acyl-hydrazones (mixed species) are highlighted in blue.
Hydrogel formation upon addition of terphthalaldehyde (CL) to DCLs
20 dominated by **1₅** and post-modified by d) glyoxylyl-RGD (**1₅-RGD**) and e)
glyoxylyl-LDV (**1₅-LDV**). The vial inversion test indicates the formation of
hydrogels within 2 minutes after the addition of CL.

Figure 6 Representative fluorescence microscopy images of human bone
25 marrow-derived mesenchymal stem cells (hBM-MSCs) cultured on
hydrogels made from: a) **1₅** fibers; b) **1₅** fibers post-modified with glyoxal-
RGD, or c) **1₅** fibers post-modified with glyoxal-LDV, and coated on glass
coverslips in the growth medium, stained with calcein-AM (live cells) and
propidium iodide (dead cells), after 24 h. Scale bars equal to 150 μm . For
30 clarity, red circles emphasize the presence of dead cells (red). d)
Quantification of cell viability cultured on three different types of hydrogel-

coated glass coverslips in growth medium for three repetitions of each type of material. Mean \pm SD (n=3, at least three random image fields per experiment, at least 50 counted cells per image field).

Figure 7 Representative fluorescence microscopy images of hBM-MSCs cells cultured on hydrogels prepared from a) – c) 1₅ fibers; d) – f) 1₅ fibers post-assembly functionalized with glyoxylyl-RGD and g) – i) 1₅ fibers post-assembly functionalized with glyoxylyl-LDV, stained with DAPI (blue) and FITC-phalloidin (cytoskeleton), after 24 h. The bottom images represent the merge of the two channels. Scale bars equal to 300 μ m.

10

Figure 8 Representative UPLC traces of DCL prepared from mixed building blocks 1 and 16 (see Example 7A).

Figure 9 Characterization of mixed building block fibers. Panel A: The transmission electron microscopy (TEM) photograph of example 7A following covalent post-assembly modification with IPP, prior to cross-linking. Panel B: Hydrogel formation of cross-linked functionalized nanofibers prepared from mixed building blocks, with or without covalent post-assembly modification.

Figure 10 A synthetic strategy towards mimicking the native extracellular matrix. Acyl-hydrazone bond formation can be employed to achieve: a) cross-linking of peptide-based, fibrous self-assemblies yielding hydrogel formation; b) immobilization of bioactive short peptide sequences within the material; c) decoration of fibrillar scaffold with full-length proteins and growth factors, and/or d) tuning in protease-sensitive peptides as cross-linkers that would facilitate cell-induced enzymatic remodeling of the gel. As fibers bear NH-NH₂ groups (reactivity B), biologically relevant ligands comprising reactivity C and cross-linkers comprising reactivity D, e.g. mono- or di- carbonyl-functionalized, form a reactive pair (B-C and B-D). This

unique modular approach allows the molecular engineering of tailor-made material on demand.

EXPERIMENTAL SECTION

5

Materials

Cross-linkers were purchased from TCI Chemicals, Sigma-Aldrich, Acros Organics, or Creative PEGworks. Boric anhydride (Sigma-Aldrich) and sodium hydroxide (Merck Chemicals) were utilized for buffer preparation and pH adjustments. The concentration of borate buffer is given in $B_4O_7^{2-}$ ions. Acetonitrile (UPLC-MS grade), water (UPLC-MS grade), DMF (HPLC grade), and trifluoroacetic acid (HPLC grade) were purchased from Biosolve BV. Building block 1 was purchased from Cambridge Peptides Ltd. (Birmingham, U.K.) by coupling 3,5-bis(tritylthio)-benzoic acid, which was synthesized via a previously reported procedure[11a] at the N-terminus. Glyoxylyl-RGD and glyoxylyl-LDV were purchased from Cambridge Peptides Ltd. (Birmingham, U.K.) and GenScript Biotech (Piscataway, New Jersey, USA), respectively. Gels were prepared on round, 12 mm diameter, and 0.17 mm thick borosilicate glass coverslips (Fischerbrand). Costar® multiple well plates (24 well, Corning® CellBIND® surface, polystyrene) were purchased from Corning and used for cell culture. Human bone marrow-derived mesenchymal stem cells (hBM-MSCs) were used for cell experiments. The growth medium supplemented with Alpha modified Eagle's medium (Gibco), 10% fetal bovine serum (Gibco), 0.1% ascorbic acid 2-phosphate (Sigma), and 1% penicillin/streptomycin (Gibco) and trypsin (Sigma-Aldrich) were utilized for cell culture and harvesting, respectively. Dyes propidium iodide and calcein-AM were obtained from Sigma-Aldrich and Thermo Fisher Scientific. For immunostaining cells were incubated with a primary antibody for vinculin (clone hVin-1, Sigma), followed by treatment with a secondary antibody Rhodamine Red™-X-

labeled goat-anti-mouse antibody (Jackson Immunolab). The nucleus and cytoskeleton were stained with DAPI (4',6-diamidino-2-phenylindole) and TRITC-phalloidin purchased from Sigma-Aldrich. EM-grade PFA was purchased from Electron Microscopy Sciences.

5

General methods

Fiber preparation

Building block 1 was dissolved to a concentration of 4.0 mM in borate buffer (12.5 mM in $B_4O_7^{2-}$, pH 8.2) to obtain a fiber forming solution. Due to 1 being a salt of TFA, the pH value had to be re-adjusted to 8.2 with 1M NaOH. Subsequently, the solution was oxidized to approximately 40% with $NaBO_3$ (40 mM). The sample was equilibrated in a UPLC vial (12 x 32 mm) with a Teflon-coated screw cap. The UPLC vial was equipped with a 15 cylindrical stirring bar (2 x 5 mm, Teflon-coated, purchased from VWR), and the solution was stirred at 1200 rpm using an IKA C-MAG HS 7 control hot plate stirrer. The temperature was kept constant at 25 °C using a Thermo Scientific Compact Digital Dry Bath.

20 *UPLC/MS analysis*

UPLC/MS measurements were performed using a Waters Acquity UPLC H-class system coupled to Waters Xevo-G2 TOF. The mass spectrometer was operated in the positive electrospray ionization mode with the following ionization parameters: capillary voltage: 3 kV, sampling cone voltage: 20 V, 25 extraction cone voltage: 4 V, source gas temperature: 120°C, desolvation gas temperature: 450°C, cone gas flow (nitrogen): 1 L/h, desolvation gas flow (nitrogen): 800 L/h.

Atomic force microscopy (AFM)

30 AFM samples were prepared by depositing 100 μ L of a sample (diluted to 10 μ M concentration of 1 with UPLC water) onto a clean mica surface (Grade

V1, Van Loenen Instruments). Subsequently, the excess solvent was evaporated by blotting into a piece of paper, the surface was washed twice with 100 μ L UPLC grade water, blotted into a piece of paper and finally dried in a gentle stream of air. The AFM measurements have been performed using a Bruker Multimode 8 instrument in ScanAsyst-Air imaging mode. Measurements were performed in air at room temperature. As a probe, a ScanAsyst Air (Bruker) silicon tip on a nitride cantilever was used with the following parameters: length: 115 μ m, width: 25 μ m, resonance frequency: 70 kHz, force constant: 0.4 N/m. The images were recorded with frequencies between 0.5 and 1.5 Hz and analyzed with NanoScope Analysis 1.50 software (Bruker Corporation, 2015).

Post-assembly functionalization of fibers with glyoxylyl-RGD and glyoxylyl-LDV and gel preparation

Self-assembly **1₅** was obtained by oxidizing building block **1** under basic conditions ([**1**] = 4.0 mM, 12.5 mM borate buffer, pH 8.2). After UPLC/MS analysis confirmed that DCLs are dominated by assembly **1₅**, 10 mol% of glyoxal-RGD and glyoxal-LDV was added, and the library was stirred for another 30 min. The reaction between the aldehyde and **1₅** was confirmed by UPLC/MS, where mixed species (**1₄1₁1₃1₁2** and **1₄1₂1₃1₂2/1₂1₂3**) were observed. To a fiber solution post-modified with monoaldehyde, a portion of cross-linker **4** was added to achieve hydrogelation. The remaining reactive groups of fibers and cross-linkers were kept constant at a molar ratio of 1:1.

UPLC analysis

UPLC measurements were performed on a Waters Acquity UPLC H-class system equipped with a PDA detector. UPLC analyses were performed on an Acquity UPLC Peptide CSH C18 1.7 μ m (150 x 2.1 mm) column, purchased from Waters, using UPLC-MS grade water (eluent A) and UPLC-MS grade acetonitrile (eluent B), containing 0.1 V/V % TFA as a modifier. A

flow rate of 0.3 mL/min and a column temperature of 35°C were applied. Spectra were recorded at a detection wavelength of 254 nm.

Preparation of gel-coated cover slips and cell seeding

5 Glass coverslips were plasma treated for 5 min in PlasmaFlecto 10 to enhance the surface's wettability and adhesion. The reactive groups of fibers and cross-linkers were kept constant at a molar ratio of 1:1. The stock solution of cross-linker **CL** was prepared by dissolving the compound in acetone. Gels were prepared by mixing 100 µL of fiber solution (4.0 mM in building block 1) with 2 µL of cross-linker stock solution, in an Eppendorf. 10 Before gelation occurred, 25 µL (preliminary cytotoxicity experiments) or 50 µL (cytotoxicity of modified gels, cell morphology experiments) of the mixture was placed on top of the coverslip and left undisturbed until gelation was complete (app. 5 min). Coverslips were transferred into a 24- 15 well plate. To each of the wells containing gel-coated coverslip, 250 µL of MiliQ water was added to prevent gel drying for the duration of UV-treatment. Gels were sterilized with UV-light for 15 minutes. After sterilization, cells were seeded on top of hydrogels at the app. 10000 cell/mL of culture medium ($V = 1$ mL per well), for all experiments. Plates were 20 incubated at 37°C, 5% CO₂, at maximum humidity. Live/dead staining was performed after 24 h, proliferation kinetics was followed for five days (day 1, 3, and 5), while cell morphology when cells are seeded on top or encapsulated was assessed after one day.

25 *Staining for assessment of cell morphology*

For assessment of cell morphology, cells were rinsed with PBS and fixed for 15 min using warm 3.7% EM-grade paraformaldehyde (PFA) solution in PBS after 24h. Afterward, the membranes of the cells were permeabilized with 0.5% Triton-X 100 solution in PBS for 3 min, and non-specific 30 background was blocked with 5% bovine serum albumin (BSA) in PBS for 30 minutes. The nucleus and cytoskeleton of fixed cells were stained with DAPI

and FITC-labelled phalloidin. The working solution was prepared in PBS containing 1% bovine serum albumin (BSA) by adding FITC-labelled phalloidin (final concentration = 2 $\mu\text{g}/\text{mL}$) and DAPI (final concentration = 4 $\mu\text{g}/\text{mL}$) and protected from light. The hydrogels were incubated with a
5 sufficient amount of working solution to completely cover the sample ($V = 400 \mu\text{L}$) in the dark, for an hour, and subsequently visualized by fluorescence microscopy.

Confocal microscopy and image analysis

10 Cells were imaged with Celldiscoverer 7 with Plan-APOCHROMAT 5x/0.35 air objective (Carl Zeiss AG, Oberkochen, Germany) and TissueFAXs (TissueGnostics GmbH, Vienna, Austria) microscopes. Cell quantification was performed in ImageJ. Data are given as mean values \pm standard deviation (SD).

15

EXAMPLE 1: Peptide-based fiber formation

This example describes the use of dynamic combinatorial chemistry for the formation of fiber-like, supramolecular polymers from pseudo-peptide
20 building blocks. We designed a pseudo-peptide building block **1** (Figure 1a) of the formula A-Peptide-B, with three distinctive features: (i) a dithiol, aromatic core to promote thiol-disulfide exchange and stacking via π - π interactions (A); (ii) a short peptide chain that will assist self-assembly and is biocompatible (Peptide);[9,15] and (iii) a hydrazide-functionalized C-
25 terminus representing further chemical reactivity (B) through a second dynamic covalent bond.

Upon exposure to air, pseudopeptide building block **1** underwent oxidation to form a dynamic combinatorial library (DCL) of differently sized cyclic disulfides (**1₃**, **1₄** and **1₅**), which continuously interconvert by the thiol-
30 disulfide covalent exchange. In a such mixture, one of the rings (**1₅**) can form stacks with copies of itself, which promotes the process of self-assembly. This shifts the distribution of the exchange pool towards the synthesis of

more of the self-assembling library member. Growth of the stacks from their ends, combined with breakage of stacks through mechanical agitation, results in an increase in the amount of supramolecular fibrous polymer (Fig. 1a).

5 The composition of the resulting DCL was monitored with UPLC for 23 days. The progress of **1₅** (fiber) formation was followed by sampling 5 μ L of the DCL and diluting it to 50 μ L with doubly distilled water. When **1** was depleted, and **1₅** had an abundance of at least 50 % (based on the integration of UPLC chromatograms), the solution was used for gel
10 preparation. The fiber sample was used directly since products of hydrazide hydrolysis were observed upon prolonged incubation.

Atomic force microscopy (AFM) and cryo-electron microscopy (cryo-EM) of DCLs dominated by **1₅** indicated the presence of fibers with lengths ranging from hundreds of nanometers to several micrometers (data not
15 shown).

EXAMPLE 2: Hydrogel formation and characterization

Subsequently, we investigated the capacity of the peptide-based fibers for hydrogel formation upon the addition of a di- or trialdehyde (Figure 1b) as
20 cross-linkers. The selection of cross-linkers (**CLs**) is based on differences in length and flexibility of the spacer group between the aldehyde moieties, and the number of cross-linking groups (Figure 1c). The concentration (4.0 mM in **1**) and the ratio of **1** to **CL** (1:1 in complementary functionalities i.e., NH-NH₂ and carbonyls) were kept constant in all experiments. The addition
25 of **CLs** containing short and rigid spacers (**2**, **4**, **5**, and **7**) to the solutions of pre-formed fibers did result in gel formation. Hydrogelation occurs in the span of 2 to 10 minutes, depending on the cross-linking reagent (Figure 1d). In contrast, molecules with a flexible spacer **3**, **6**, and **8** yielded viscous solutions even upon prolonged incubation. We hypothesize that an increase
30 in distance between carbonyl groups and spacer flexibility enables hydrazone formation within a single fiber.

In order to probe the concentration dependence of **1** for gel formation, we prepared a series of samples at different concentrations ranging from 4.0 mM to 0.25 mM, while using glutaraldehyde (**2**) as a model cross-linker. Remarkably, the critical gelation concentration (CGC) was found to be 0.5
5 mM (in **1**) or 0.025 wt%, which is at the low end of the scale for hydrogels reported in the literature.[16] At 0.25 mM, the sample exists as a viscous solution. The same value was found using terephthalaldehyde (**4**) as a cross-linking agent.

To directly visualize the organization of fibers, as a component of the gel
10 scaffold, we used cryo-EM and scanning electron microscopy (SEM) following drying in a high vacuum. The appearances of the samples without and with cross-linkers were remarkably identical, despite the distinct macroscopic differences. Regardless of cross-linker, the samples do not exhibit longer-range order within the hydrogel network (Figure 2).

15

EXAMPLE 3: Hydrogel stability in the presence of culture media

Maintaining bulk stability and properties of the material on the time scale of cell culture experiments is essential, as the migration of cells to the stiff
20 bottom of the culture container could lead to alteration of cell morphology. Such lack of stability would essentially reduce a 3D ECM model (if cells are encapsulated within the material) or 2D soft model (if cells are cultured on top of the soft material) to the traditional and static 2D culture on glass or plastic substrate. Both soft-material models are recognized as significantly
25 more-true to tissue microenvironments[17] since stiffness can influence stem cell lineage specification,[18] morphology, and adhesion.[19]

Therefore, prior to encapsulating cells or seeding them on top of the gels, we tested compatibility between gel material and growth medium. The growth medium used was Alpha modified Eagle's medium, containing
30 10% fetal bovine serum, 0.1% ascorbic acid 2-phosphate, and 1% penicillin/streptomycin.

The gels were prepared as described in Example 2 (Fig. 3-i), and a portion of growth medium was added on top (Figure 3-ii), to mimic an experiment involving cell seeding. The culture medium was found to diffuse inside the gel without any effect on the macroscopical level (Figure 3-iii), as evidenced by the red color of the medium penetrating the gel, while the material remained undamaged. The hydrogel was stable after prolonged incubation with culture medium (Figure 3-vi), indicating its applicability in experiments that require long-term intactness of material.

10

EXAMPLE 4: Cytocompatibility of Hydrogels

In this example, the potential cytotoxic effect of the hydrogel was evaluated based on viability levels and proliferation rate of cells, as these parameters are good indicators of cell health.

15

Cell culture hBM-MSCs

Human bone marrow-derived mesenchymal stem cells (hBM-MSCs) from Lonza (passage 2) were cultured in a growth medium supplemented with Alpha modified Eagle's medium (Gibco), 10% fetal bovine serum (Gibco), 0.1% ascorbic acid 2-phosphate (Sigma), and 1% penicillin/streptomycin (Gibco). Cells were incubated at 37°C with 5% CO₂. Every 3 days, the culture medium was refreshed, and cells were passaged or harvested at approximately 80% confluence. The confluent cells were subcultured by trypsinization. hBM-MSCs of passage 4 were used for the next experiments.

25

Live/dead staining

Live/dead staining was performed using propidium iodide and calcein-AM. Live cells were characterized by enzymatic conversion of cell-permeant, non-fluorescent calcein-AM into strongly fluorescent calcein (green) within live cells. Dead cells were characterized by propidium iodide as it binds to double-stranded DNA by intercalating between the bases but is excluded

30

from cells with intact plasma membranes. Once the dye is bound, its fluorescence is enhanced 20- to 30-fold, producing a bright red fluorescence in dead cells. The working solution was prepared in serum-free media by adding propidium iodide (final concentration = 3 μM) and calcein-AM (final concentration = 5 μM) and protected from light. Culture media was removed, and hydrogels were washed with warm PBS, to which a sufficient amount of working solution to completely cover the sample ($V = 400 \mu\text{L}$) was added. Cells were incubated at 37°C for 20 minutes and subsequently visualized by fluorescence microscopy.

10

In order to quantify the survival of cells, a live/dead analysis was performed using fluorescence microscopy. Human bone marrow-derived mesenchymal stem cells (hBM-MSCs) were seeded on top of the gels prepared by the previously established procedure, incubated for one day, and subsequently stained by two fluorescent dyes, calcein-AM and propidium iodide (PI). After a short-term culture, the hydrogel material showed a minimal negative effect on cell viability, as there are more live cells (green dye) than dead cells (red dye) as shown in Figure 4. Quantification of the number of live cells per unit macroscopic field gave a mean of $91.0 \pm 1.0\%$, among the three repetitions of the experiment.

20

To follow the change in cell number, staining with 4',6-diamidino-2-phenylindole (DAPI) at different time points, followed by fluorescence imaging was employed, as the dye strongly interacts with AT-rich regions of DNA within the nuclei. Visualization of cells within the population showed an increase in cell density over a period of five days, indicating that the material is suitable for cell survival and division. Furthermore, staining of the cytoskeleton with tetramethylrhodamine (TRITC)-phalloidin revealed that the cells do not display the rounded morphologies typical of apoptosis (data not shown), suggesting that the hydrogel chemistry is not intrinsically toxic.

30

Overall, the outcome of these *in vitro* cytotoxicity tests (cell viability and cellular proliferation) indicates cytocompatibility of the hydrogels.

5 **EXAMPLE 5: Post-assembly functionalization**

Incorporation of Cell Adhesion Motives Into Fibrillar Scaffold

As shown in the previous examples, a hydrogel based on fibers of self-assembled building blocks 1 shows sufficient mechanical stability to support cells, as well as the desired stability towards degradation by growth media, and is non-toxic. A further important aspect for application of the hydrogel in cell and tissue engineering relates to an adequate interaction between the hydrogel and cells.

15 This example illustrates the surprising finding that it is possible to incorporate biologically relevant ligands into the material, by post-assembly functionalization of peptide-based (nano)fibers and their subsequent hydrogelation. The known cell adhesion peptide motifs RGD and LDV were used as exemplary biologically active compounds for post-assembly
20 “decoration” of nanofiber assemblies. Scheme 1 shows the chemical structures of the components used. This “on-demand” approach to provide a chemically customized fibrillar scaffold is advantageously used to promote a specific cell response.

Peptide building block

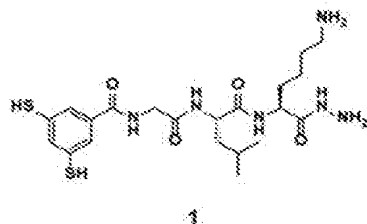

Cross-linkers

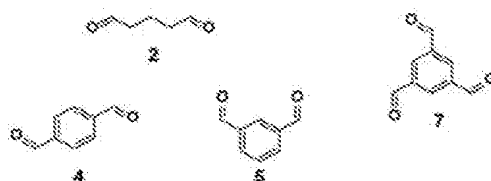

Functionalized bioactive peptides

glyoxylyl-RGD

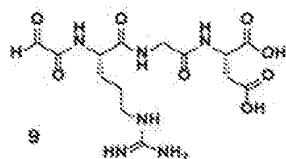

glyoxylyl-LDV

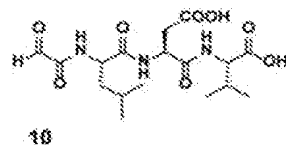

Acyl-hydrazone adducts

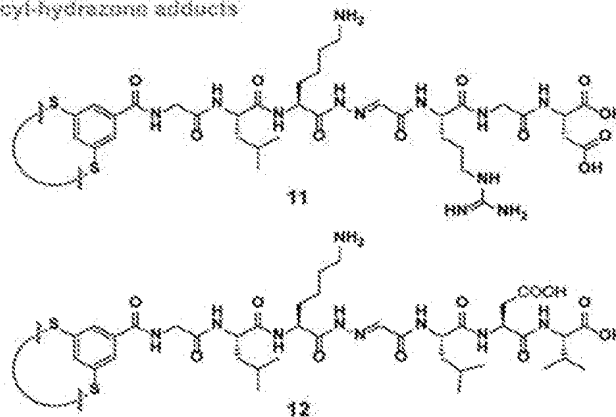

5

Scheme 1: Exemplary Dithiol pseudo-peptide building block (1) used for fiber formation; exemplary di- and trialdehydes used for cross-linking of 15 fibers for hydrogel formation: glutaraldehyde (2), terephthalaldehyde (4), isophthalaldehyde (5), and benzene – 1,3,5 – tricarboxaldehyde (7); carbonyl-
 10 functionalized bioactive peptides: glyoxylyl-RGD (9) and glyoxylyl-LDV (10), and corresponding acyl-hydrazone adducts 11 and 12, represented as a part of a macrocycle.

Functionalization of Fibers with Cell Adhesion Signals and Their Hydrogelation

Supramolecular, self-assembled fibrous structure (**1₅**) was obtained as described herein above. After UPLC/MS analysis confirmed that DCLs are dominated by **1₅** (Figure 5a), the preformed assembly was split into two and reacted with 10 mol% of glyoxylyl-RGD and glyoxylyl-LDV. Upon short-term stirring (30 min), UPLC traces of the two libraries showed partial covalent modification of **1₅** (Figure 5b-c). The reaction appeared to be finished within 30 minutes, as a further change in library composition was not observed even upon prolonged stirring (20 h; data not shown).

In general, incorporation of both carbonyl-functionalized peptide sequences led to the formation of mixed self-assemblies (**1₄1₁**, **1₃1₁2**, and **1₄1₂**, **1₃1₂2**, **1₂1₂3**), while **1₅** also remained present. As remaining hydrazide groups ought to participate in hydrogel formation, partial covalent modification is desired. Atomic force micrographs of DCLs dominated by pentamer species functionalized with biologically relevant peptides demonstrate the presence of fibers, similar to the original library composed of **1₅** (data not shown).

Next, the possibility for customized, functionalized fibers to undergo hydrogelation upon the addition of a cross-linker was investigated. Vial-inversion tests indicate gel formation in 2 minutes, for fibers functionalized with either glyoxylyl-RGD (Figure 5d) or glyoxylyl-LDV (Figure 5e).

These data show that acyl-hydrazone chemistry allows for a quick and efficient customization of (nano)fibers by biologically relevant ligands, as well as their hydrogelation. It demonstrates the unique capacity of the “post-assembly” decorated peptide-based (nano)fibers of the invention to undergo hydrogelation. Apparently, the addition of a functional group of interest does not interfere with the hydrogelation induced by cross-linking.

This approach can find application in the fabrication of versatile materials by simple “decoration” of the fibrillar scaffold.

EXAMPLE 6: Application in cell culture

5

This example describes the characterization of spreading and organization of the actin cytoskeleton in order to evaluate the effectiveness of hydrogel materials functionalized with RGD or LDV. Furthermore, to assess whether the presence of signaling peptides has an effect on cell viability, live/dead staining was performed on cells in the presence of material based on pseudo-peptide 1_5 and functionalized with glyoxylyl-RGD or glyoxylyl-LDV. For identifying the influence of these peptide motifs on the morphology of the cells, hBM-MSCs were cultured on modified substrates and allowed to attach/spread for 1 day prior to visualization.

15

Live/Dead Viability Assay of Cells Cultured on hydrogels functionalized with Cell Adhesion Signals

Cytotoxicity of hydrogel material based on 1_5 -RGD or 1_5 -LDV was evaluated as described herein above. Cells were seeded on the hydrogels and visualized after a one day incubation. The green (live) and red (dead) cells (Figure 6a-c) were manually counted in the three random domains per sample (n=3) per type of material. The results are shown in Figure 6d, demonstrating a high viability of cells in all cases.

25

Influence on Cell Morphology

To determine the effect of the RGD and LDV cell adhesion motifs on the morphology of human bone marrow-derived mesenchymal stem cells, the cells were cultured for one day on the original material based on either the non-functionalized 1_5 hydrogels, or on the functionalized substrates 1_5 -RGD and 1_5 -LDV. After that, cells were fluorescently labelled to visualize their

30

nuclei (DAPI) and cytoskeleton (FITC), (Figure 7a-i). From fluorescent imaging of the cytoskeleton (Figure 7) it was observed that hBM-MSCs exhibit extended morphologies on all three types of materials, without significant discrepancies. The absence of notable effect of cell adhesion peptides on cell morphology, but also of cells with rounded morphology on the original substrate, indicate that peptide sequence of 1, GLK, on its own promotes cell spreading. To the best of our knowledge, this peptide sequence has not been reported as a cell adhesion motif (naturally or synthetically derived) thus far.

10

EXAMPLE 7: Post-assembly functionalization and hydrogel formation of functionalized nanofibers prepared from mixed pseudopeptide building blocks.

15 This example describes DCLs of mixed building blocks (A-Peptide-B and A-Peptide) that are capable of being modified, and then induces to undergo gel formation via dialdehyde cross-linking.

General procedure of dynamic combinatorial library (DCL)

20 **formation:**

A fiber forming solution was prepared by dissolving a mixture of building blocks A-Peptide-B and A-Peptide (see table 1) were dissolved in 12.5 mM in $B_4O_7^{2-}$ borate buffer in different predetermined molar ratios, so that the total building block concentration was 4.0 mM. The pH was adjusted to 8.2 with 1.0 M NaOH, and the DCLs were left stirring at 1200 rpm for 20 days at 32°C.

25

Table 1. Conditions and detected species of dynamic combinatorial libraries of mixed building blocks.

Example	Building block #1 A-Peptide-B	Building block #2 A-Peptide	Molar Ratio	Species formed
A	XGLK-NH ₂ (1)	XGLKFK (16)	3:1, 1:1, 1:3	1₁16₂, 1₂16₁, 1₂16₂, 1₂16₃, 1₁16₄
B	XGLK-NH ₂ (1)	XGLKAK (17)	3:1, 1:1, 1:3	1₂17₂, 1₁17₂, 1₂17₁, 1₁17₇, 1₂17₆, 1₃17₅, 1₄17₄
C	XGLK-NH ₂ (1)	XGSK (18)	3:1	1₁18₃, 1₂18₂, 1₂18₃, 1₃18₂, 1₄18₁, 1₁18₂, 1₂18₁
D	XGLK-NH ₂ (1)	X(p-NH ₂ -F)K (19)	1:1	1₁19₃, 1₂19₂, 1₃19₁, 1₁19₂, 1₂19₁
E	XGLK-NH ₂ (1)	XK (20)	3:1	1₁20₃, 1₂20₂, 1₃20₁, 1₃20₂, 1₄20₁, 1₁20₂, 1₂20₁
F	XGLK-NH ₂ (1)	XK-NH ₂ (21)	1:1	1₁21₃, 1₂21₂, 1₃21₁, 1₁21₂, 1₂21₁
G	XGIK-NH ₂ (13)	XGLKFK (16)	1:1	1₃216₂, 1₃16₃, 1₃216₃, 1₃16₄, 1₃216₁, 1₃16₂
H	XGAK-NH ₂ (14)	XGLKFK (16)	1:1	1₄216₂, 1₄216₁, 1₄16₃, 1₄216₃, 1₄16₅, 16₆
I	X(p-NH ₂ -F)K-NH ₂ (15)	-		15₆

Scheme 2. Structures of C-terminal hydrazide building blocks A-Peptide-B (13-15) and C-terminal acid building blocks A-Peptide (16-20) that formed gels upon cross-linking with dialdehyde 4.

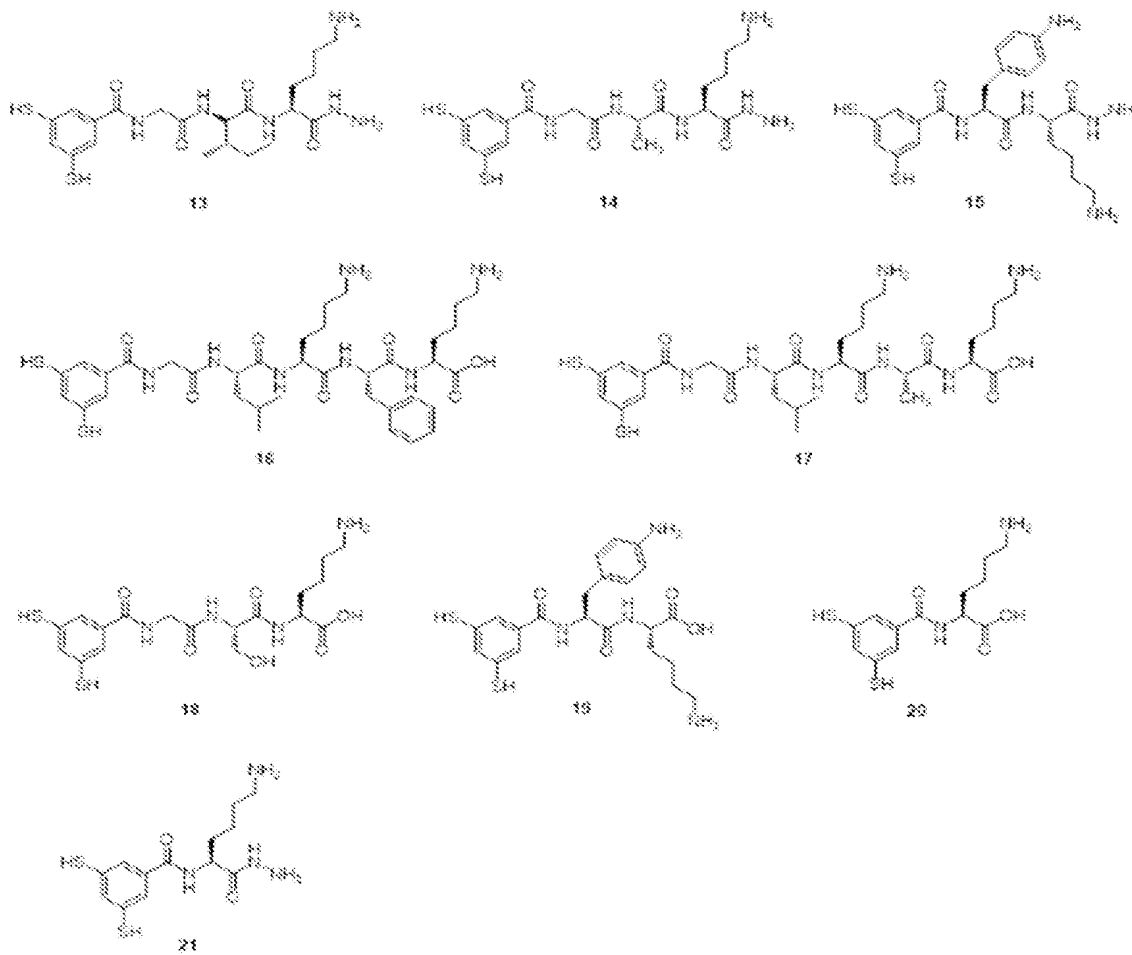

Scheme 3. (4-Formylbenzoyl)-IPP peptide (**22**) and acyl-hydrazone adducts (**23-26**):

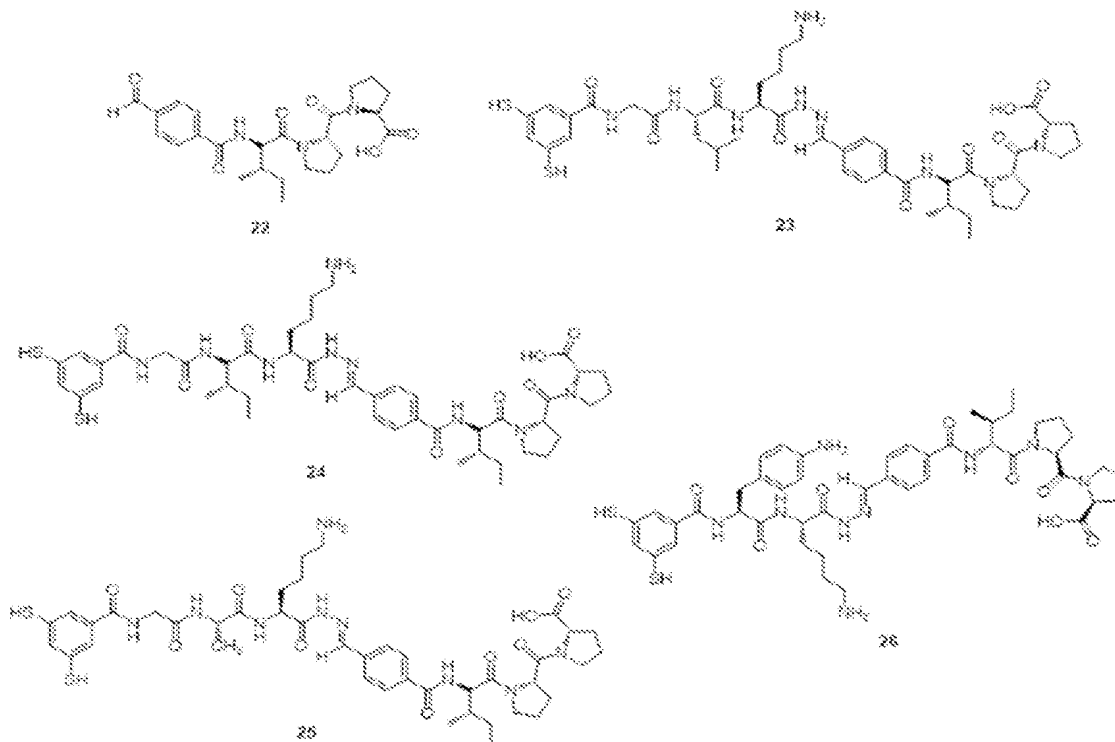

5

General procedure of post-assembly functionalization of fibers from a mixed building block system with biologically active peptide IPP.

Self-assembly of a mixed system of building blocks was obtained according to the general procedure. When the macrocycles interconversion was completed and the DCL composition is stable for several days, 10 mol. % of IPP derivative **22** (4-formylbenzoyl-IPP) was added. The tripeptide Ile-Pro-Pro (IPP) is implicated among others in osteoblast differentiation, which is relevant for biomineralization and bone formation.

The DCL was stirred for 30 minutes at 1200 rpm, and the appearance of macrocycles containing acyl-hydrazone adducts **23-26** (incorporated into the disulfide macrocycles) was confirmed by UPLC/MS. Hydrogels from the IPP-

functionalized samples were obtained according to the general procedure of a hydrogel preparation.

Results

The UPLC traces Figure 8 show the formation of new mixed species between building blocks and their development in time (day 0, 10 and 20) of DCL from representative example 7A. By day 20, the DCL is dominated with mixed pentamer species (**1₂16₃** and **1₁16₄**) that form fibers. Upon functionalization of fibers with addition of biologically active substance **22**, the intensity of **1₂16₃** and **1₁16₄** peaks decreased. At the same time, the appearance of new broad peaks **1₃16₁23**, **1₂16₂23** and **16₄23** in area 8.4-8.9 minutes were observed. These peaks are adducts of chemical interaction between **22** and pentamer species **1₂16₃**, **1₃16₂** and **1₁16₄**, providing evidence of covalent post-modification of fibers.

Table 2 shows the elution times of the formed species after 20 days of stirring of the 1:1 mixture at 1200 rpm.

Table 2

Species	UPLC elution time, min	UPLC/MS elution time, min
1₁	6.44	6.88
16₁	7.80	8.28
1₂16₂	7.77	8.09
1₂16₃	7.91	8.35
1₁16₄	8.02	8.46
1₂16₁	8.28	8.72
1₁16₂	8.41	8.85
16₃	8.58	9.03
IPP-functionalized macrocycles		
1₃16₁23	8.15	8.60
1₂16₂23	8.26	8.71

1₁16₂23	8.32	8.77
1₁16₃23	8.38	8.82
16₄23	8.45	8.91

The transmission electron microscopy (TEM) picture of Figure 9A demonstrates the fibers formed in DCL from example 7A (after functionalization with IPP and before cross-linking).

- 5 Essentially the same results were obtained using the 3:1 or 1:3 mixture of building blocks **1** and **16**, and for the other mixed building block systems of Examples 7B-7H (data not shown).

Example 7I concerns a fiber forming solution with only A-Peptide-B building blocks **15**, wherein Peptide is dipeptide (p-NH₂)-F-K, comprising a
10 hydrazide B-moiety. This building block forms fibers, can be functionally modified e.g. with IPP or RGD peptides, and can form a gel (data not shown).

Example 8: Hydrogel formation of functionalized nanofibers prepared from mixed building blocks.

In this example, the IPP-functionalized nanofibers according to examples 7A-7G were cross-linked to undergo hydrogelation. To that end,
5 functionalized fiber solutions were cross-linked with dialdehyde 4, giving a firm elastic material, which sticks to the walls of a glass vial. Non-functionalized nanofibers were included as control to investigate the effect of post-assembly modification on gelation.

As is shown in Figure 9B, non-functionalized as well as IPP-functionalized
10 nanofibers of representative example 7B gave rise to a solid gel. The same results were obtained using the other mixed building block systems (data not shown).

REFERENCES

- 15 [1] a) H. Shin, S. Jo, A. G. Mikos, *Biomaterials* **2003**, *24*, 4353-4364; b) P. X. Ma, *Adv. Drug. Deliv. Rev.* **2008**, *60*, 184-198; c) J. Patterson, M. M. Martino, J. A. Hubbell, *Mater. Today* **2010**, *13*, 14-22.
- [2] a) C. A. E. Hauser, S. Zhang, *Chem. Soc. Rev.*, **2010**, *39*, 2780-2790; b) S. Zhang, *Nat. Biotechnol.* **2003**, *21*, 1171-1178.
- 20 [3] H. Cui, M. J. Webber, S. I. Stupp, *Biopolymers* **2010**, *94*, 1-18.
- [4] a) O. J. G. M. Goor, S. I. Hendrikse, P. W. Dankers, E. W. Meijer *Chem. Soc. Rev.* **2017**, *46*, 6621-6637; b) K. Sato, M. P. Hendricks, L. C. Palmer, S. I. Stupp, *Chem. Soc. Rev.* **2018**, *47*, 7539-7551.
- [5] P. Y. W. Dankers, M. C. Hamsen, L. A. Brouwer, M. J. A. van Luyn, E.
25 W. Meijer, *Nat. Mater.* **2005**, *4*, 568-574.
- [6] G. A. Silva, C. Czeisler, K. L. Niece, E. Beniash, D. A. Harrington, J. A. Kessler, S. I. Stupp *Science*, **2004**, *303*, 1352-1355.
- [7] M. P. Lutolf, J. L. Lauer-Fields, H. G. Schmoekel, A. T. Metters, F. E. Weber, G. B. Fields, J. A. Hubbell *Proc. Natl. Acad. Sci. USA*, **2013**, *100*,
30 9413-9418.

- [8] M. P. Lutolf, J. A. Hubbell, *Nat. Biotechnol.* **2005**, *1*, 47-55.
- [9] P. Worthington, D. J. Pochan, S. A. Langhans, *Front. Oncol.* **2015**, *92*, 1-10.
- [10] D. Seliktar, *Science*, **2012**, *336*, 1124-1128.
- 5 [11] a) J. M. A. Carnall, C. A. Waudby, A. M. Belenguer, M. C. A. Stuart, J. J.-P. Peyralans, S. Otto, *Science*, **2010**, *327*, 1502-1506; b) M. Colomb-Delsuc, E. Mattia, J. W. Sadownik, S. Otto, *Nat. Commun.* **2015**, *6*, 7427-7433; c) Y. Altay, M. Tezcan, S. Otto, *J. Am. Chem. Soc.* **2017**, *139*, 12459-14662; d) J. W. Sadownik, D. Philp, *Angew. Chem. Int. Ed.* **2008**, *47*, 9965-9970; e) T. Kosikova, Douglas Philp, *J. Am. Chem. Soc.* **2019**, *141*, 3059-3072; f) B. Liu, C. G. Pappas, E. Zangrando, N. Demitri, P. J. Chmielewski, S. Otto, *J. Am. Chem. Soc.* **2019**, *141*, 1685-1689; g) C. G. Pappas, P. K. Mandal, B. Liu, B. Kauffmann, X. Miao, D. Komáromy, W. Hoffmann, C. Manz, R. Chang, K. Liu, K. Pagel, I. Huc, S. Otto, *Nat. Chem.* **2020**, *12*, 1180-1186.
- 10 [12] a) G. Deng, F. Li, H. Yu, F. Liu, C. Liu, W. Sun, H. Jiang, Y. Chen, *ACS Macro Lett.* **2012**, *1*, 275-279; b) L. He, D. Szopinski, Y. Wu, G. A. Luinstra, P. Theato, *ACS Macro Lett.* **2015**, *4*, 673-678.
- [13] M. M. Perera, N. Ayers, *Polym. Chem.* **2020**, *11*, 1410-1423.
- 20 [14] a) J. Chen, Q. Su, R. Guo, J. Zhang, A. Dong, C. Lin, J. Zhang, *Macromol. Chem. Phys.* **2017**, *218*, 1700166; b) J. Collins, M. Nadgorny, Z. Xiao, L. A. Connal, *Soft Matter* **2013**, *9*, 4635-4641.
- [15] a) A. N. Jonker, D. W. P. M. Löwik, J. C. M. van Hest, *Chem. Mater.* **2012**, *24*, 759-773; b) J. Li, R. Xing, S. Bai, X. Yan, *Soft Matter.* **2019**, *15*, 1704-1715.
- 25 [16] X. Du, J. Zhou, J. Shi, B. Xu. *Chem. Rev.* **2015**, *115*, 13165-13307.
- [17] B. M. Baker, C. S. Chen, *J. Cell. Sci.* **2012**, *125*, 3015-3024.
- [18] A. J. Engler, S. Sen, H. L. Sweeny, D. E. Discher, *Cell*, **2016**, *126*, 677-689.
- 30 [19] M. Sun, G. Chi, P. Li, S. Lv, J. Xu, Z. Xu, Y. Xia, Y. Tan, J. Xu, L. Li, Y. Li, *Int. J. Med. Sci.* **2018**, *15*, 257-268.

Claims

1. A method for providing peptide-based functionally modified (nano)fibers, comprising the steps of :
- 5 (i) providing a fiber forming solution comprising pseudopeptide building blocks of the formula A-Peptide-B, wherein:
- Peptide is a moiety of 1 to 8, preferably 3 to 5, amino acid residues having a sequence that is predisposed to form a one-dimensional array, such as β -sheet fibrils;
- 10 A is an aromatic moiety carrying two reactive thiol groups; and
B is a reactive α -nucleophile;
- (ii) exposing the fiber forming solution to oxidizing conditions to induce supramolecular self-assembly of the pseudopeptide building blocks into peptide-based (nano)fibers; and
- 15 (iii) contacting said (nano)fibers with at least one biologically relevant functional group of interest comprising reactivity C forming a reactive pair with B to obtain covalently functionally modified nanofibers.
2. Method according to claim 1, wherein A comprises a 5- or 6-membered
20 thiol-substituted aromatic ring, preferably a thiol-substituted benzene.
3. Method according to claim 1 or 2, wherein B is or comprises a -NH-NH₂ or a -O-NH₂ functionality, preferably wherein B is -NH-NH₂.
- 25 4. Method according to claim 3, wherein the pseudopeptide building block is of the formula I, II, III or IV

30

Formula I

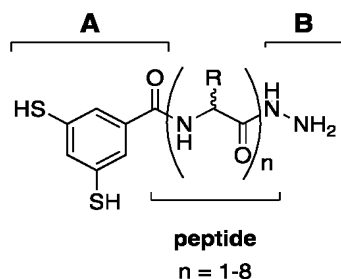

Formula II

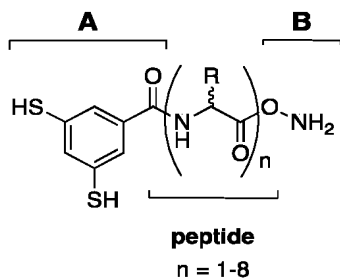
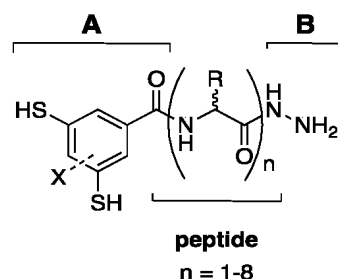

Formula III

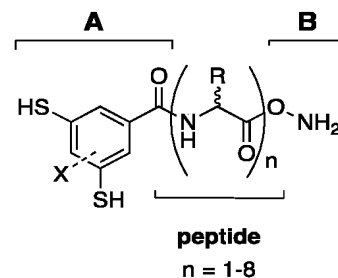

Formula IV

- 5 wherein R is any natural or non-natural amino acid side chain
 X is halogen, preferably fluorine, or C₁-C₃ alkyl,
 preferably CH₃.
5. Method according to any one of the preceding claims, wherein the fiber
 10 forming solution further comprises pseudopeptide building blocks of
 the formula A-Peptide, preferably wherein the fiber forming solution
 comprises a mixture of A-Peptide-B and A-Peptide in a molar ratio of
 4:1 to 1:4, more preferably 3:1 to 1:3.
- 15 6. Method according to any one of the preceding claims, wherein the
 Peptide moiety comprises alternating hydrophobic and hydrophilic
 amino acid residues.

7. Method according to any one of the preceding claims, wherein the Peptide moiety comprises or consists of the formula
- (i) Xaa1-Xaa2-Xaa3, wherein
- Xaa1 is Gly, Ala, Val, Ile or Phe, preferably Gly;
- 5 Xaa2 is Gly, Ala, Val, Ile or Phe; and
- Xaa3 is Lys, Arg or His, preferably Lys;
- (ii) Xaa1-Xaa2-Xaa3-Xaa4-Xaa5-Xaa6, wherein
- Xaa1 is Gly, β -Ala or γ -aminobutyric acid (GABA)
- Xaa2 is Ala, Val, Leu, Ile or Phe
- 10 Xaa3 is Lys, Arg or His, preferably Lys
- Xaa4 is Ala, Val, Leu, Ile or Phe
- Xaa5 is Lys, Arg or His, preferably Lys
- Xaa6 is Asp, Glu, or absent.
- 15 8. Method according to any one of the preceding claims, wherein reactivity C comprises a carbonyl-functionality, preferably an aldehyde or glyoxylyl group.
9. Method according to any one of the preceding claims, wherein the
- 20 biologically relevant functional group of interest is a biologically active peptide, preferably selected from the group consisting of growth factors, differentiation factors, cytokines, chemokines, cell adhesion ligands, or wherein the biologically relevant functional group of interest is or comprises
- a protease-degradation site, such as a substrate for matrix
- 25 metalloproteinases (MMPs).
10. Method according to any one of the preceding claims wherein step
- (iii) comprises contacting said (nano)fibers with two or more different
- biologically relevant functional groups of interest, either sequentially or
- 30 simultaneously.

11. A method for providing a peptide-based functionalized hydrogel, comprising providing peptide-based functionally modified (nano)fibers according to a method of any one of the preceding claims, followed by adding a crosslinker comprising a plurality of reactive groups D capable of reacting
5 with B to induce hydrogelation of the functionally modified (nano)fibers.
12. Method according to claim 11, wherein reactive group D comprises a carbonyl-functionality, preferably an aldehyde, more preferably wherein the crosslinker is a di- or trialdehyde, most preferably selected from
10 the group consisting of glutaraldehyde, 2,5-thiophenedicarboxaldehyde, terephthalaldehyde, isophthalaldehyde, succinaldehyde, substituted versions of benzene-1,3 and 1,4 biscalboxaldehydes, and benzene- 1,3,5-tricarboxaldehyde.
- 15 13. Peptide-based functionally modified (nano)fibers obtainable by a method according to any one of claims 1-10.
14. A peptide-based functionalized hydrogel obtainable by a method according to claim 11 or 12.
20
15. The use of peptide-based functionally modified (nano)fibers according to claim 13 and/or a peptide-based functionalized hydrogel according to claim 14 in tissue engineering.
- 25 16. A method for tissue engineering, comprising contacting cells with a peptide-based functionalized hydrogel according to claim 14.
17. A composition comprising (i) peptide-based functionally modified (nano)fibers according to claim 13 and/or a peptide-based functionalized
30 hydrogel according to claim 14 and (ii) cells, preferably mammalian cells.

18. A tissue-engineering scaffold, comprising:
(a) a microporous scaffold comprising a biocompatible material suitable for use in tissue-engineering scaffolds, wherein said biocompatible material is a biocompatible polymer that comprises a biodegradable polymer; and
5 (b) a peptide-based functionalized hydrogel according to claim 14.
19. A kit-of-parts for use in a method of claims 1-12, comprising
(i) pseudo-peptide building blocks of the formula A-Peptide-B, wherein Peptide comprises 1 to 8, preferably 3 to 5, amino acid residues; A is an
10 aromatic moiety carrying two thiol groups capable of undergoing reversible thiol-disulfide exchange; B is a reactive α -nucleophile; and
(ii) one or more functional group(s) of interest comprising reactivity C capable of reacting with B.
- 15 20. A kit-of-parts for providing a functionalized hydrogel, comprising
(i) peptide-based (nano)fibers comprising moiety B being a reactive α -nucleophile, the (nano) fibers being prepared from pseudo-peptide building blocks of the formula A-Peptide-B, wherein Peptide
comprises 1 to 8, preferably 3 to 5, amino acid residues; A is an
20 aromatic moiety carrying two thiol groups capable of undergoing reversible thiol-disulfide exchange; and
(ii) one or more functional group(s) of interest comprising reactivity C capable of reacting with B.
- 25 21. Kit-of-parts according to claim 19 or 20, wherein B is or comprises a -NH-NH₂ or a -O-NH₂ functionality, and wherein C comprises a carbonyl-functionality, preferably wherein C is an aldehyde or glyoxylyl group.
22. Kit-of-parts according to any one of claims 19-21, further
30 comprising a cross-linking agent.

Fig. 1A

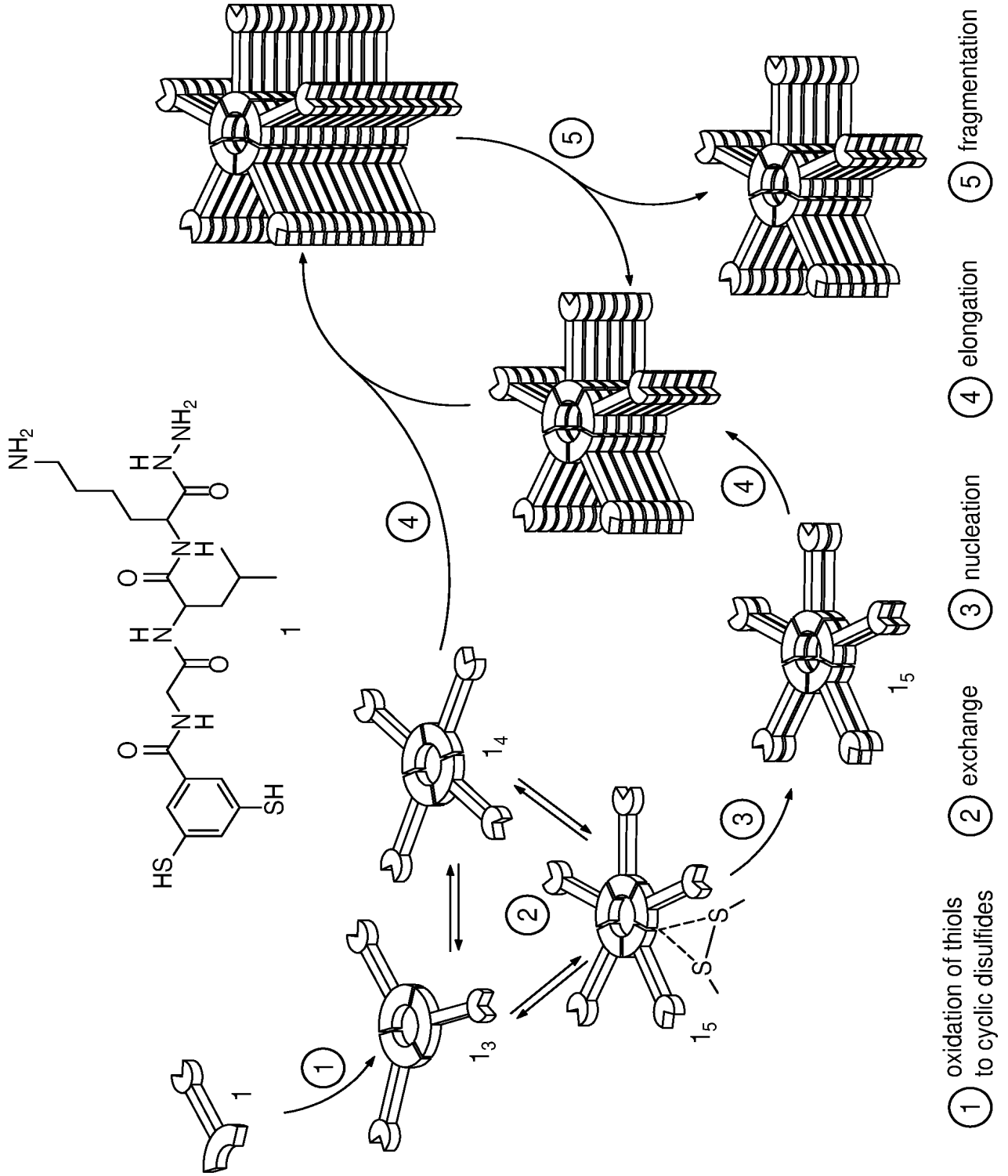

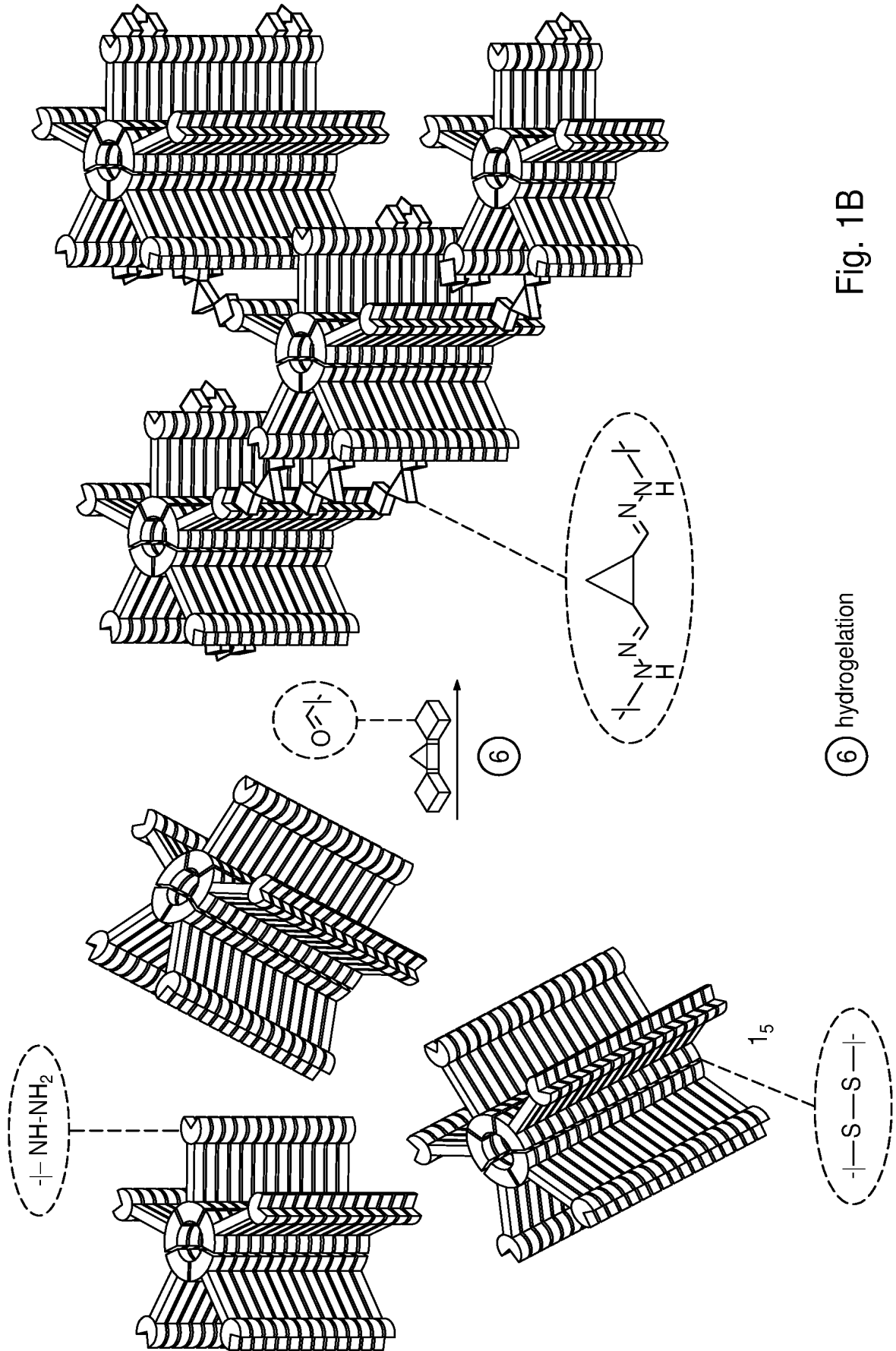

Fig. 1B

⑥ hydrogelation

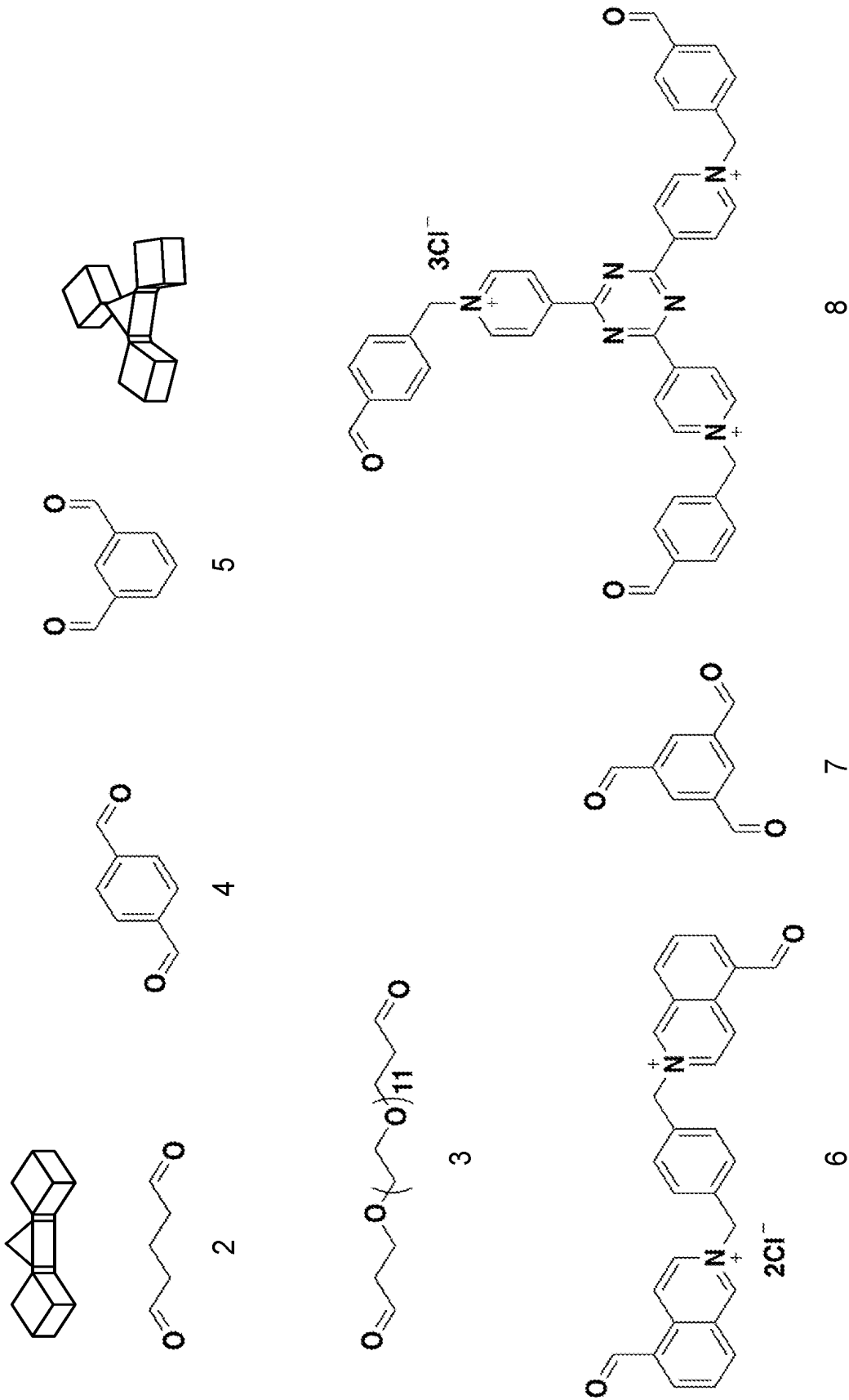
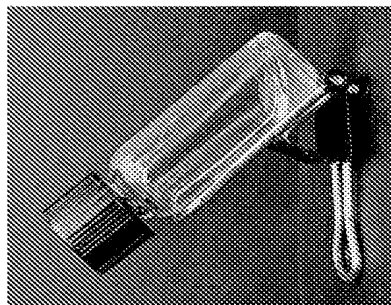
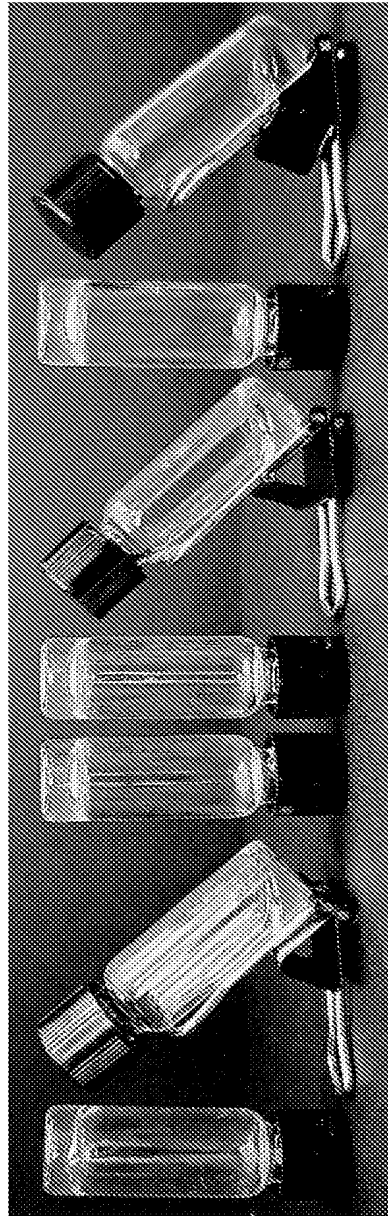

Fig. 1C



fiber solution	CL	2	3	4	5	6	7	8
	eq. of CL	0.5	2	0.5	0.5	2	0.33	1.32
	gelation time (min)	10	/	2	2	/	2	/

Fig. 1D

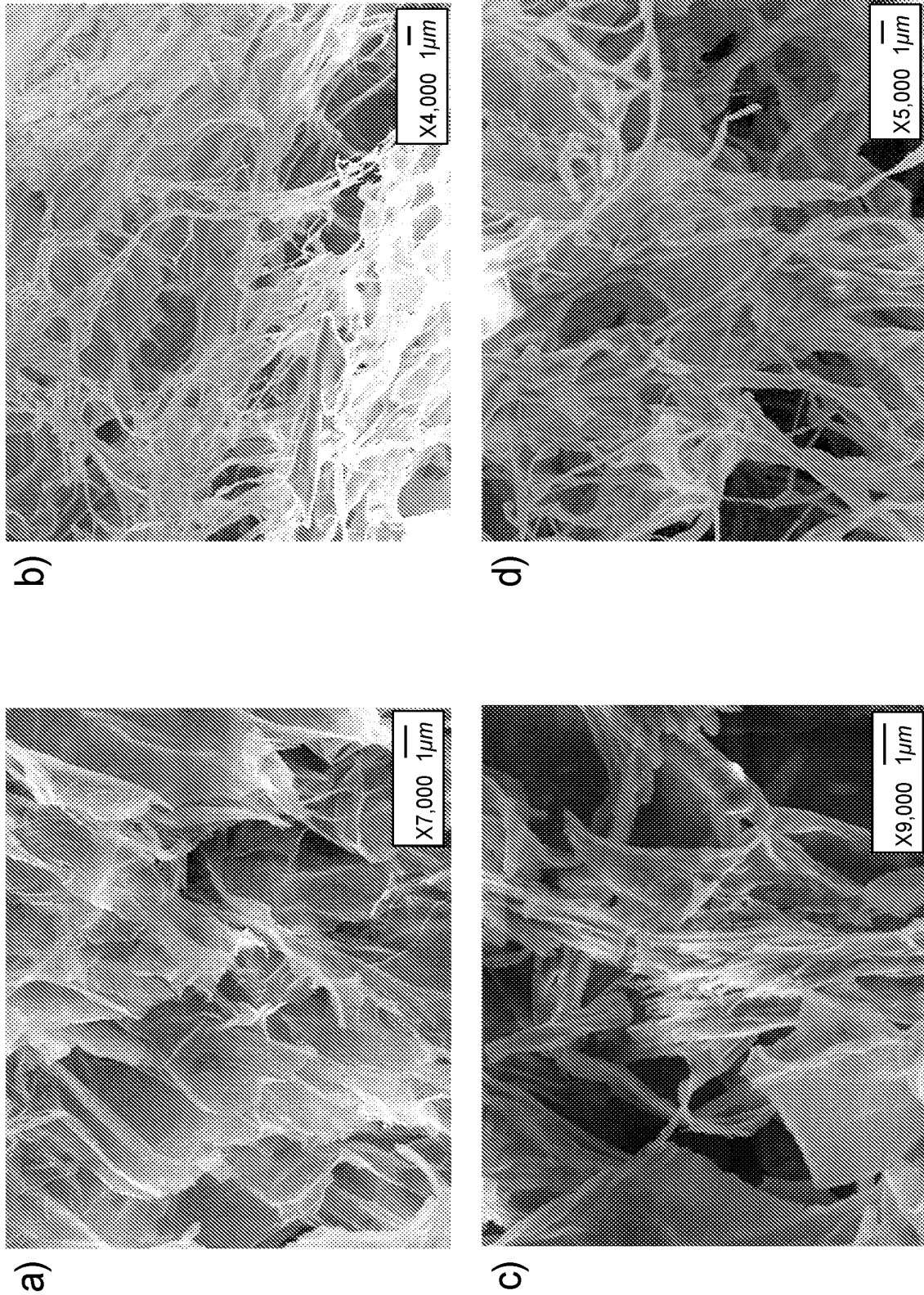

Fig. 2

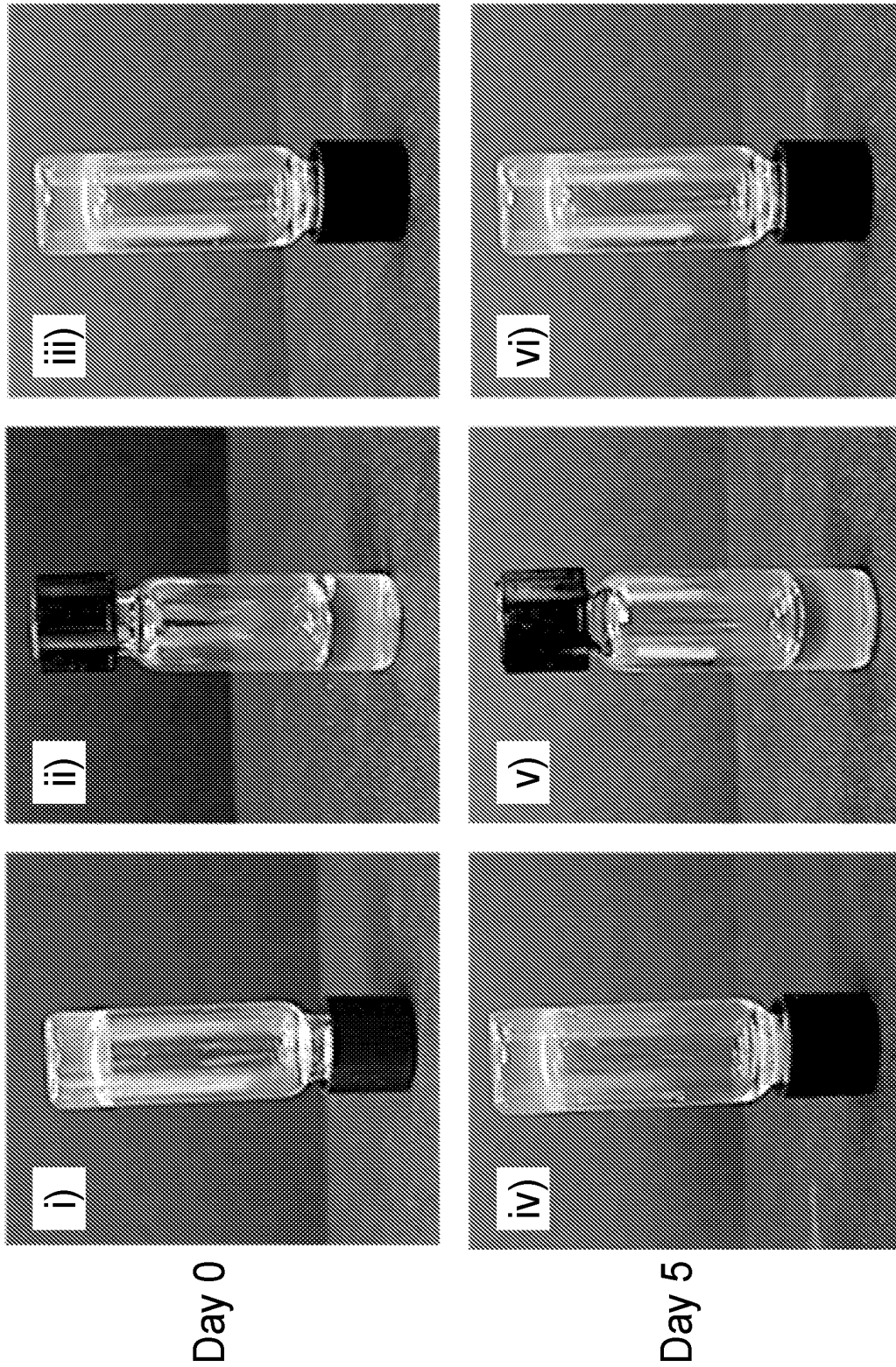

Fig. 3

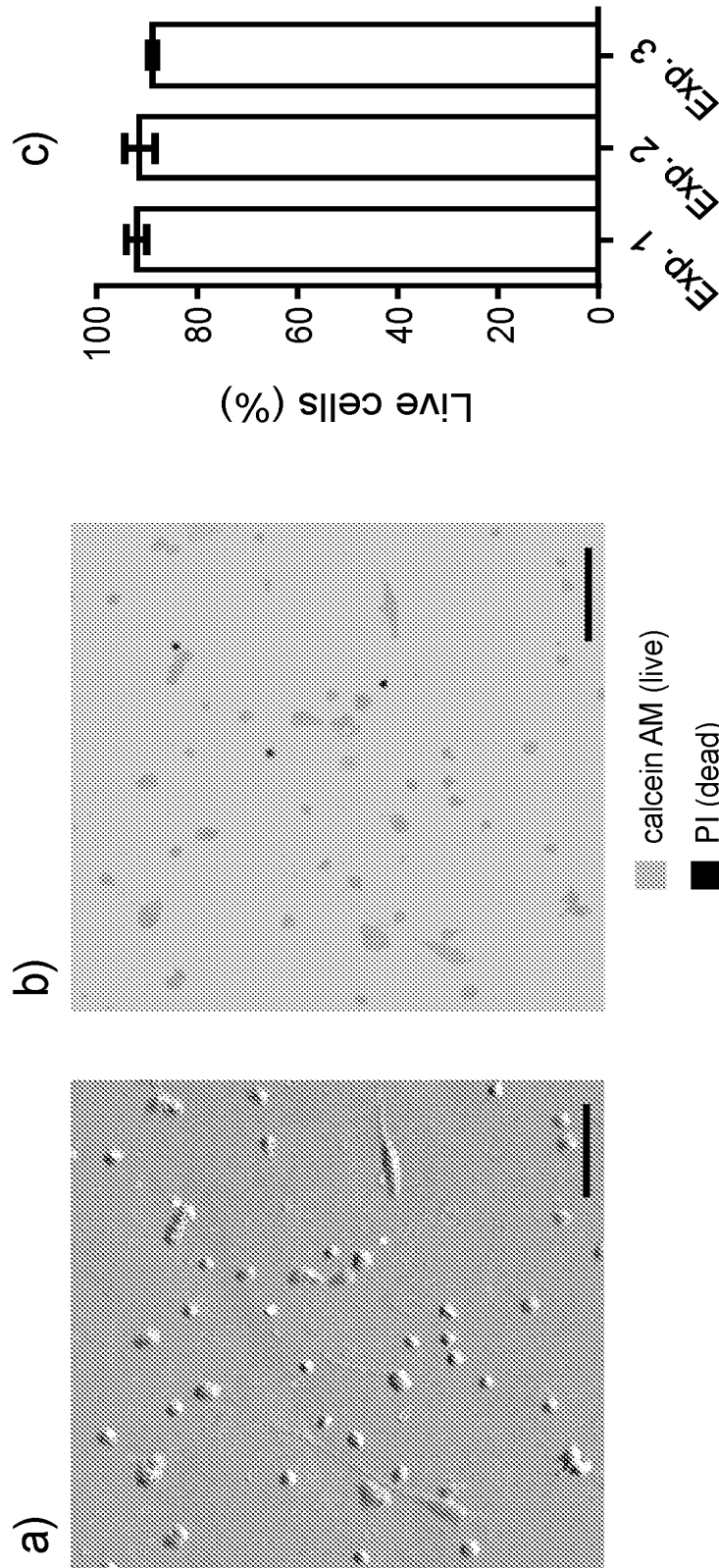

Fig. 4

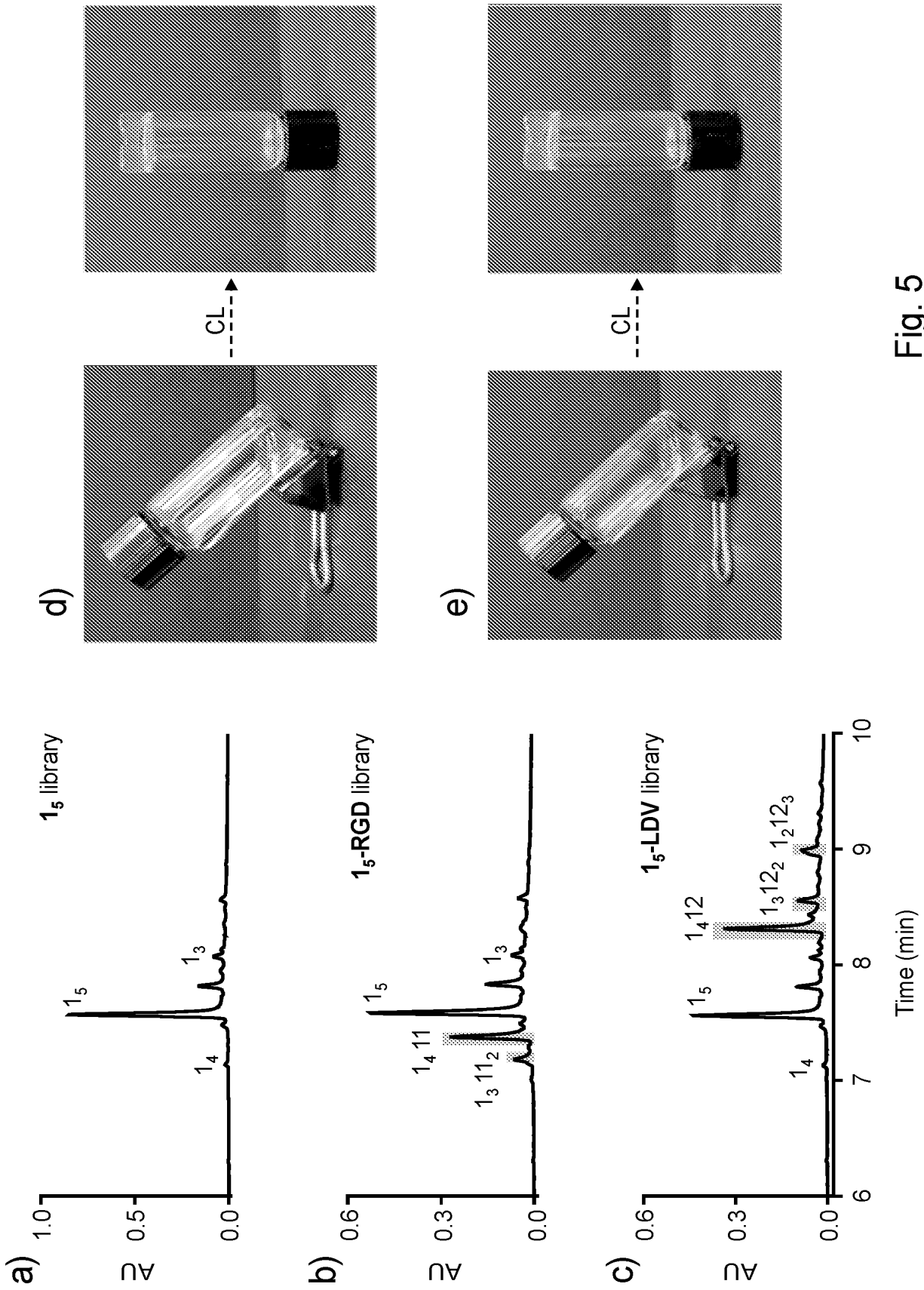

Fig. 5

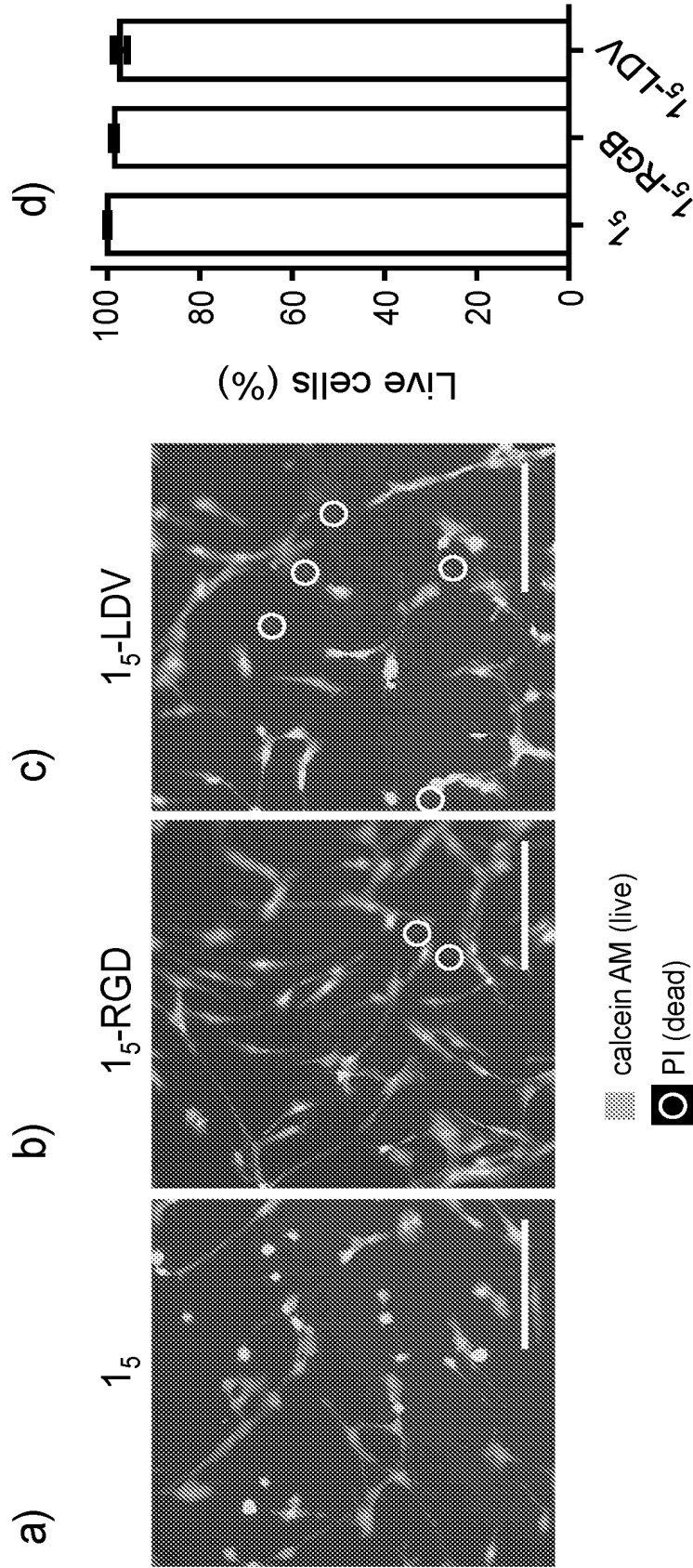

Fig. 6

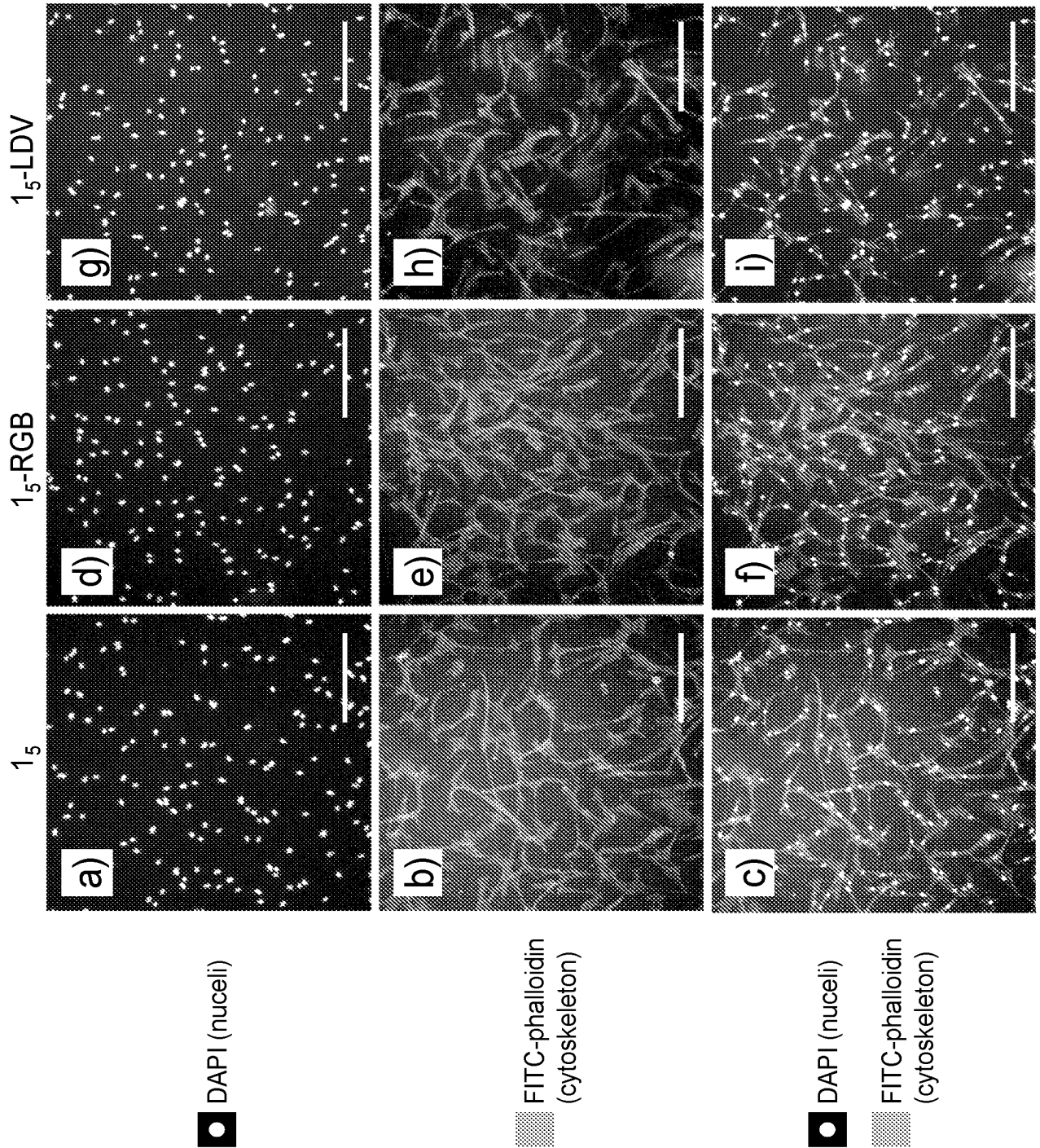

Fig. 7

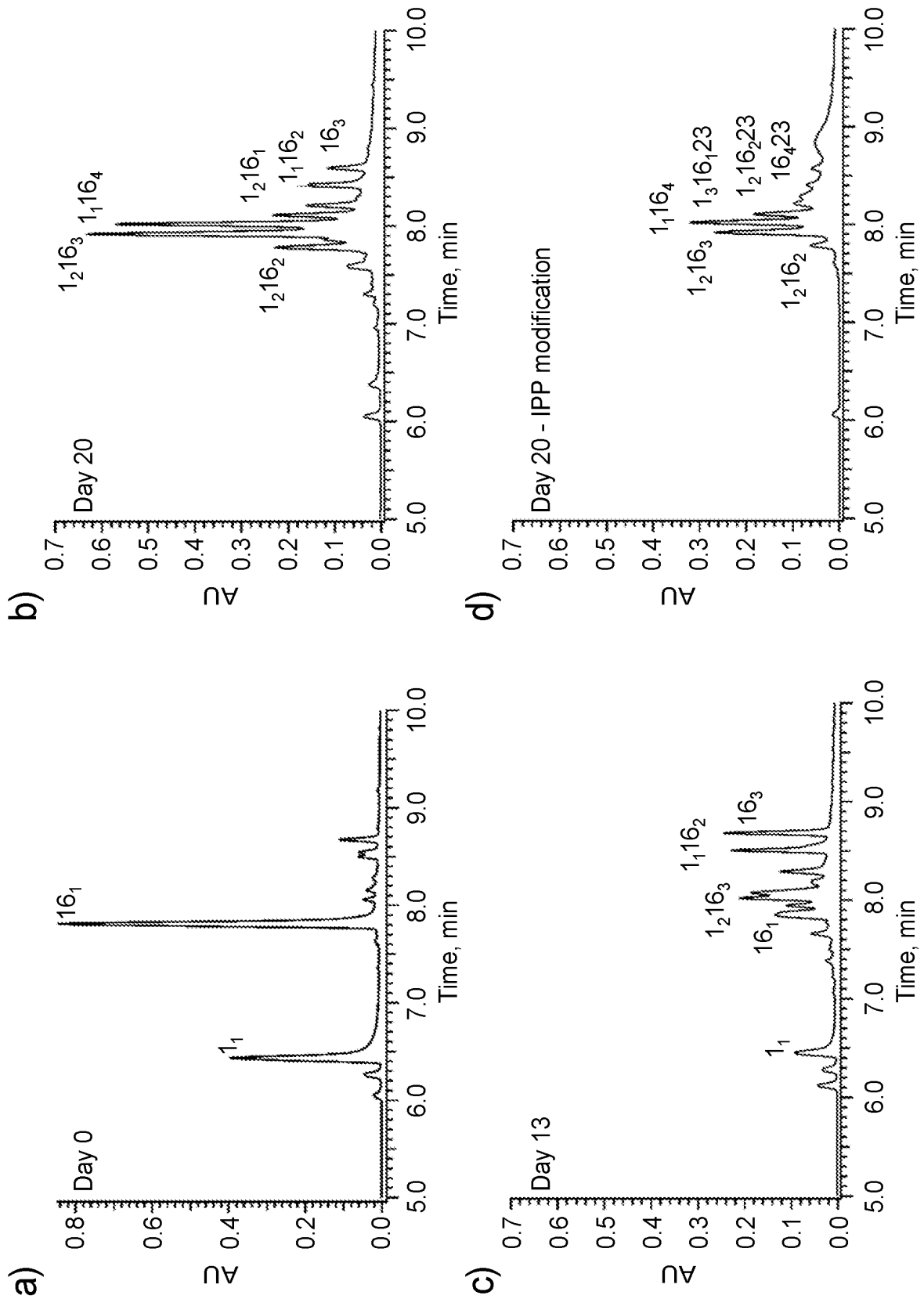
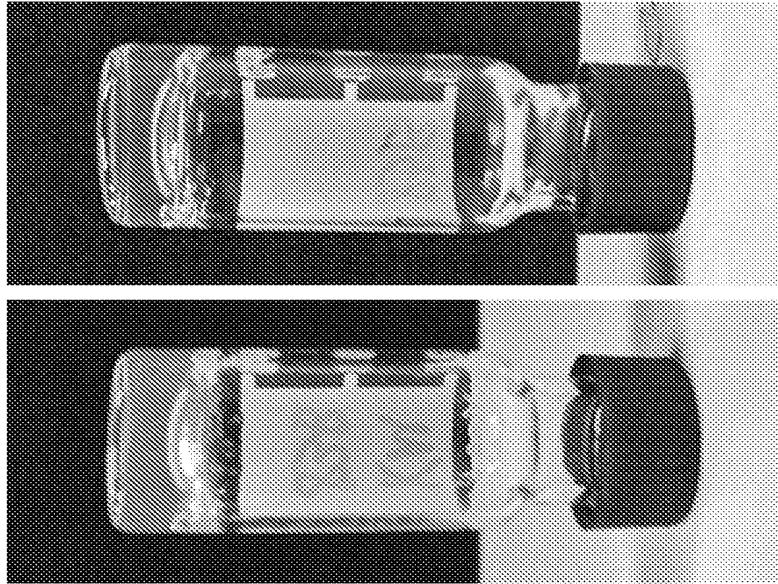

Fig. 8



Hydrogel from
IPP functionalized
nanofibers

Hydrogel from
non-functionalized
nanofibers

Fig. 9B

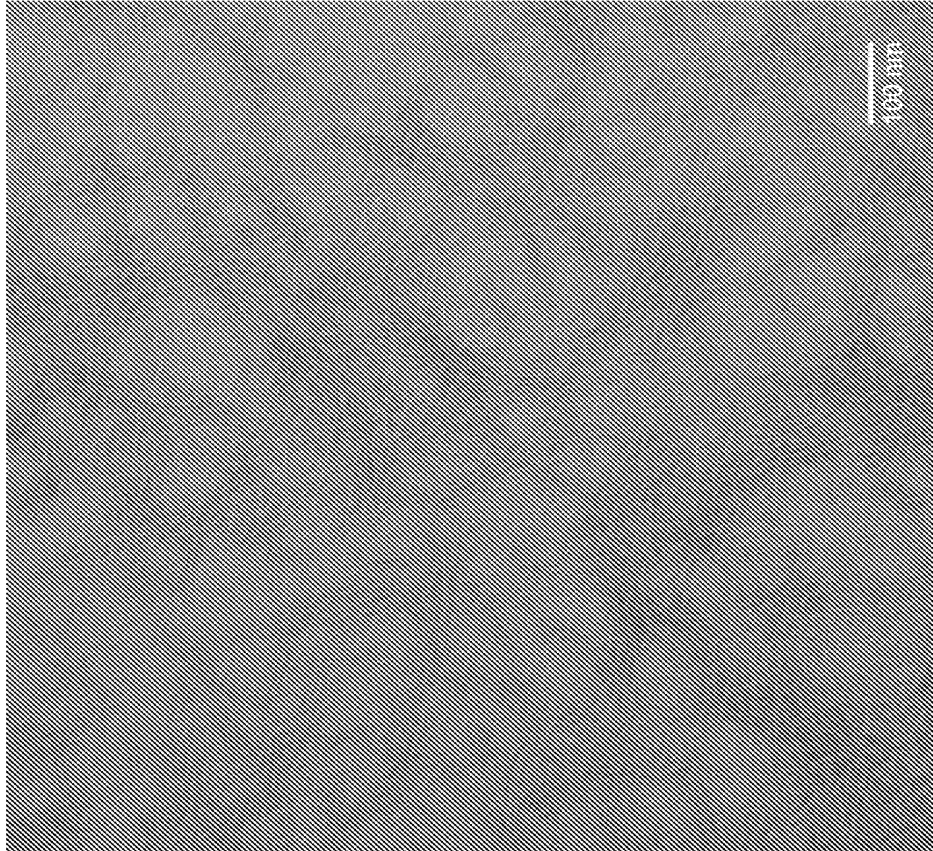

Fig. 9A

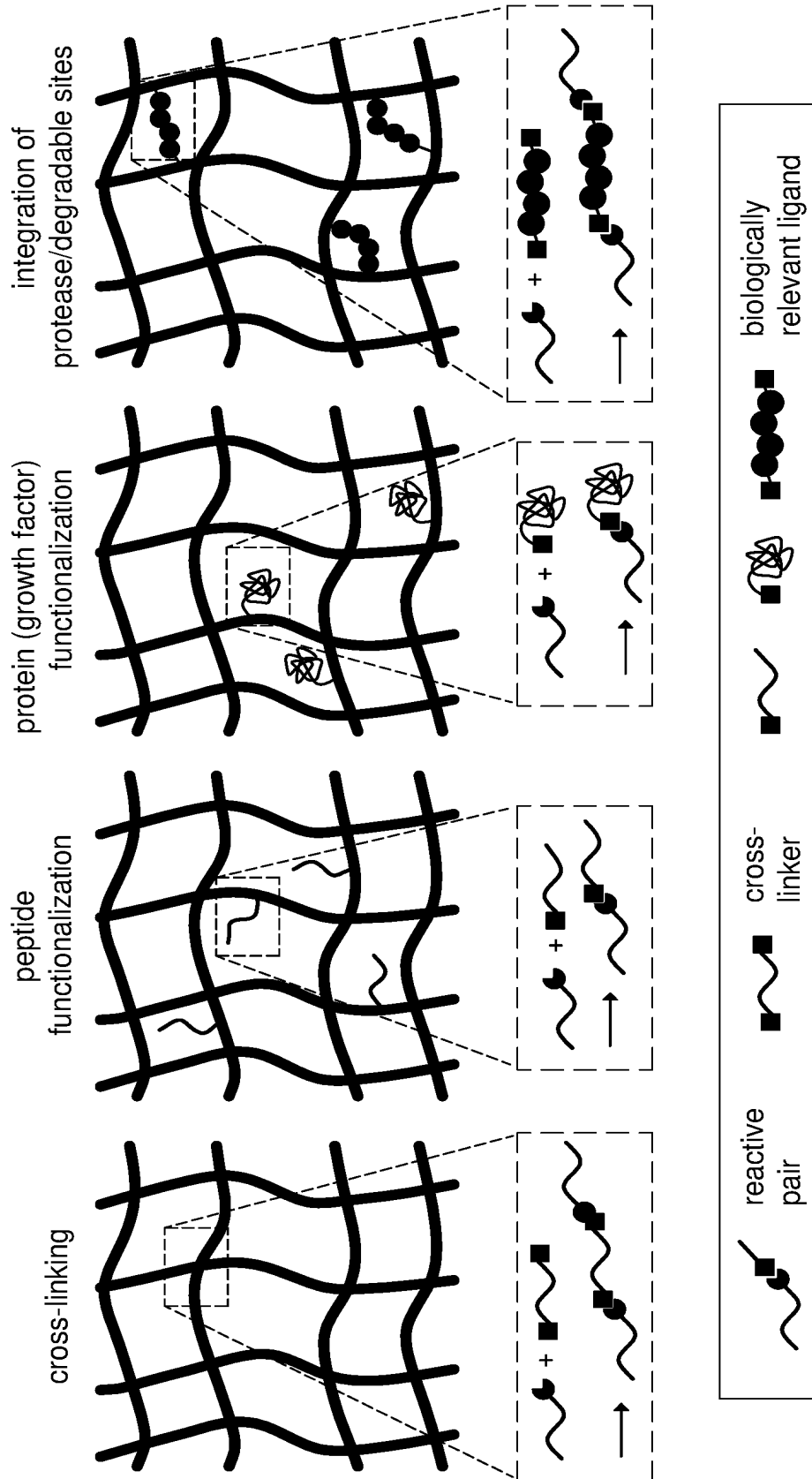

Fig. 10

INTERNATIONAL SEARCH REPORT

International application No
PCT/NL2022/050173

A. CLASSIFICATION OF SUBJECT MATTER
INV. C07K5/00 A61K38/00 A61L27/52
ADD.

According to International Patent Classification (IPC) or to both national classification and IPC

B. FIELDS SEARCHED
 Minimum documentation searched (classification system followed by classification symbols)
C07K A61L A61K

Documentation searched other than minimum documentation to the extent that such documents are included in the fields searched

Electronic data base consulted during the international search (name of data base and, where practicable, search terms used)
EPO-Internal, BIOSIS, EMBASE, WPI Data

C. DOCUMENTS CONSIDERED TO BE RELEVANT

Category*	Citation of document, with indication, where appropriate, of the relevant passages	Relevant to claim No.
X	NGUYEN VAN DUC ET AL: "Multi-step control over self-assembled hydrogels of peptide-derived building blocks and a polymeric cross-linker", SOFT MATTER (PRINT), vol. 12, no. 2, 12 October 2015 (2015-10-12), pages 432-440, XP055871333, GB	1, 2, 5-15
Y	ISSN: 1744-683X, DOI: 10.1039/C5SM02088C Abstract; Fig. 1	1-22
	----- -/--	

Further documents are listed in the continuation of Box C. See patent family annex.

* Special categories of cited documents :

"A" document defining the general state of the art which is not considered to be of particular relevance	"T" later document published after the international filing date or priority date and not in conflict with the application but cited to understand the principle or theory underlying the invention
"E" earlier application or patent but published on or after the international filing date	"X" document of particular relevance;; the claimed invention cannot be considered novel or cannot be considered to involve an inventive step when the document is taken alone
"L" document which may throw doubts on priority claim(s) or which is cited to establish the publication date of another citation or other special reason (as specified)	"Y" document of particular relevance;; the claimed invention cannot be considered to involve an inventive step when the document is combined with one or more other such documents, such combination being obvious to a person skilled in the art
"O" document referring to an oral disclosure, use, exhibition or other means	"&" document member of the same patent family
"P" document published prior to the international filing date but later than the priority date claimed	

Date of the actual completion of the international search 13 July 2022	Date of mailing of the international search report 29/07/2022
--	---

Name and mailing address of the ISA/ European Patent Office, P.B. 5818 Patentlaan 2 NL - 2280 HV Rijswijk Tel. (+31-70) 340-2040, Fax: (+31-70) 340-3016	Authorized officer López García, F
--	--

INTERNATIONAL SEARCH REPORT

International application No

PCT/NL2022/050173

C(Continuation). DOCUMENTS CONSIDERED TO BE RELEVANT		
Category*	Citation of document, with indication, where appropriate, of the relevant passages	Relevant to claim No.
A	<p>SOTIRIOS KOUTSOPOULOS: "Self-assembling peptide nanofiber hydrogels in tissue engineering and regenerative medicine: Progress, design guidelines, and applications : Self-Assembling Peptides in Tissue Engineering and Regeneration", JOURNAL OF BIOMEDICAL MATERIALS RESEARCH PART A, vol. 104, no. 4, 25 January 2016 (2016-01-25), pages 1002-1016, XP055491859, US ISSN: 1549-3296, DOI: 10.1002/jbm.a.35638 Abstract; Fig. 2, 3, 5</p> <p style="text-align: center;">-----</p>	1-22
Y	<p>PRESTWICH G D ET AL: "Controlled chemical modification of hyaluronic acid: synthesis, applications, and biodegradation of hydrazide derivatives", JOURNAL OF CONTROLLED RELEASE, ELSEVIER, AMSTERDAM, NL, vol. 53, no. 1-3, 30 April 1998 (1998-04-30), pages 93-103, XP004121260, ISSN: 0168-3659, DOI: 10.1016/S0168-3659(97)00242-3 Abstract; Fig. 1,2</p> <p style="text-align: center;">-----</p>	1-22
A	<p>WO 2014/039245 A1 (UNIV CALIFORNIA [US]; MAYNARD HEATHER D [US] ET AL.) 13 March 2014 (2014-03-13) Abstract; Fig. 1</p> <p style="text-align: center;">-----</p>	1-22
Y	<p>LI JIANWEI ET AL: "Hydrogel Formation upon Photoinduced Covalent Capture of Macrocyclic Stacks from Dynamic Combinatorial Libraries", ANGEWANDTE CHEMIE INTERNATIONAL EDITION, vol. 50, no. 36, 29 August 2011 (2011-08-29), pages 8384-8386, XP055871641, ISSN: 1433-7851, DOI: 10.1002/anie.201103297 Scheme 1</p> <p style="text-align: center;">-----</p> <p style="text-align: center;">-/--</p>	1-22

INTERNATIONAL SEARCH REPORT

International application No
PCT/NL2022/050173

C(Continuation). DOCUMENTS CONSIDERED TO BE RELEVANT		
Category*	Citation of document, with indication, where appropriate, of the relevant passages	Relevant to claim No.
Y	<p>MENZIES DONNA J. ET AL: "Tailorable Cell Culture Platforms from Enzymatically Cross-Linked Multifunctional Poly(ethylene glycol)-Based Hydrogels", BIOMACROMOLECULES, vol. 14, no. 2, 11 February 2013 (2013-02-11), pages 413-423, XP055932948, US ISSN: 1525-7797, DOI: 10.1021/bm301652q Title; Abstract; Fig. 1;p. 415, right hand column, "Gelation", last paragraph -----</p>	1-22
X	<p>LIU CHANG ET AL: "Preparation and applications of peptide-based injectable hydrogels", RSC ADVANCES, vol. 9, no. 48, 9 September 2019 (2019-09-09), pages 28299-28311, XP055871511, GB ISSN: 2046-2069, DOI: 10.1039/C9RA05934B Title; Abstract; table 1; p. 28300, left hand column, penultimate sentence -----</p>	1-22
X	<p>MARIC IVANA: "The quest for function in systems with two dynamic covalent bonds: supramolecular self-assembly, self-replication and hydrogels for biomedical applications", UNIVERSITY OF GRONINGEN, 1 January 2021 (2021-01-01), pages 1-287, XP055932684, DOI: 10.33612/diss.167788912 Retrieved from the Internet: URL:https://pure.rug.nl/ws/portalfiles/portal/167788934/Complete_thesis.pdf> the whole document -----</p>	1-22

INTERNATIONAL SEARCH REPORT

Information on patent family members

International application No

PCT/NL2022/050173

Patent document cited in search report	Publication date	Patent family member(s)	Publication date
WO 2014039245 A1	13-03-2014	US 2015202305 A1	23-07-2015
		WO 2014039245 A1	13-03-2014
