

Defining the cost of water impact for thermoelectric power generation

Fontina Petrakopoulou

Thermal and Fluid Engineering Department, Universidad Carlos III de Madrid, Avda. de la Universidad 30, 28911 Leganés (Madrid), Spain

ARTICLE INFO

Article history:

Received 9 October 2020
Received in revised form 10 March 2021
Accepted 3 April 2021
Available online 20 April 2021

Keywords:

Energy and water nexus
Power plants
Coal
Natural gas
Water cost
Cooling water system

ABSTRACT

Thermal power plants use large amounts of water, mainly for cooling purposes. Over a long operational period, power-plant cooling can have a large impact on the water source: elevated temperatures of return flows alter the local physical and chemical properties of the water (i.e., quality impact), while water consumption reduces the available water reserves for future and down-stream uses (i.e., Quantity impact). The vulnerability of the energy sector to water availability is an important problem and measures to confront or mitigate this challenge have not yet been adopted. Here, a novel, straightforward methodology to calculate the cost of water impact caused by coal and natural-gas (combined-cycle) plants with once-through and wet-recirculating cooling systems is developed. The goal is to internalize systemic costs related to water use impacts and thereby incentivize more sustainable energy generation practices. The impact is calculated here as a theoretical feedback on the plant's operational costs, since altered water properties will eventually lead to malfunction or part-load operation. The main parameter affecting the cost of water impact is found to be the temperature rise of the cooling water in the condenser. In plants with once-through cooling systems, the quantity and quality impacts of water use are of a comparable magnitude. The cost of water impacts in facilities with wet-recirculating cooling systems, on the other hand, is determined only by their quantity impact on water resources. Overall, recirculating systems result in a significantly lower water cost when compared to once-through systems. Furthermore, an approximately three times higher cost of water impact is calculated for coal plants in comparison to natural gas plants, which clearly demonstrates the importance of operational efficiency on the water use of power plants.

© 2021 The Author. Published by Elsevier Ltd. This is an open access article under the CC BY-NC-ND license (<http://creativecommons.org/licenses/by-nc-nd/4.0/>).

1. Introduction

The negative impacts of water scarcity and deterioration of its quality emphasize the need for a change in the way water availability and use is valued (Garrick et al., 2017; United Nations, World Bank, 2017). Currently, 41% and 42% of the freshwater withdrawn in the United States and Europe, respectively, is used in the energy sector, mainly in thermoelectric plants that rely on large quantities of water for cooling purposes (Medarac et al., 2018; Miara et al., 2017). China is also strongly dependent on thermoelectric plants, and coal-fired power plants are found to be responsible for around one-tenth of the country's total freshwater withdrawals (Wu et al., 2019).

Cooling water systems of thermal power plants withdraw and consume large quantities of water. Of the four types of cooling systems implemented in power plants, two use water as the cooling agent (wet- or closed-recirculating and once-through cooling systems), while the other two partly or completely replace the need for water with air (hybrid and dry cooling systems). Water-based systems are by far the dominant technology in use today (IEA, 2012).

Water used for cooling is either returned back to its source with modified physical and chemical properties, or it is consumed (i.e., lost), mainly due to evaporation and leakages. This has two main impacts: first, elevated temperatures of return water flows (several hundreds of power plants across the United States were found to return the water at temperatures above the limit set by law (Averyt et al., 2011)) and, second, the reduction of available water for future and downstream uses. Power plants also discharge important amounts of heavy metals like mercury, arsenic and lead, into the waters that can concentrate as they travel up the food chain and impact fish and wildlife (US EPA, 2018). The extent of the impact of power-plant operation on water resources depends on several parameters. For example, the smaller the water source, the more significant the long-term impacts of the operation of a connected power plant will be. Addressing the water-energy nexus by proposing concrete water use mitigation measures in the energy sector has so far received little attention.

Previously published work emphasizes the value of cooling water in the stability of the energy sector (Baleta et al., 2019; Behrens et al., 2017; Liu et al., 2017; Rogers et al., 2013; van Vliet et al., 2012), while more recent work has studied the effect of power plant operation on water resources (Miara et al., 2018). The water requirement of an energy conversion system depends

E-mail address: fpetrako@ing.uc3m.es.

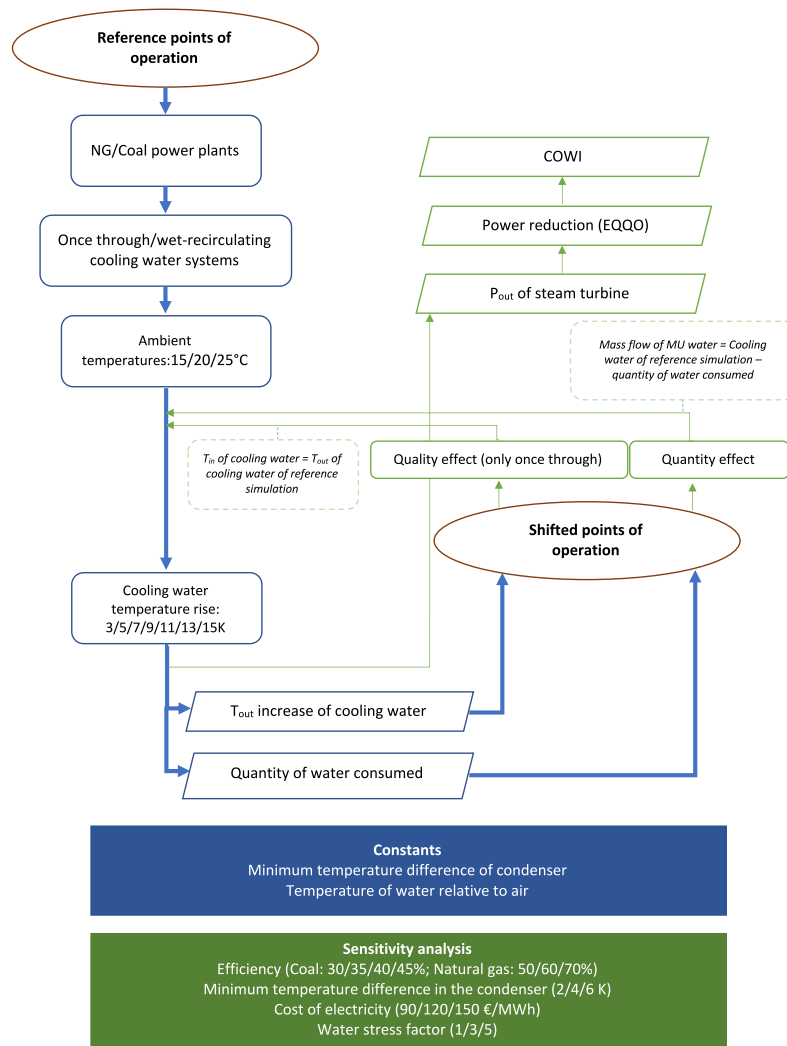

Fig. 1. Steps and characteristics of the proposed methodology.

on its operational efficiency, which is determined by the type of fuel used and the plant's technology (Ifaei and Yoo, 2019). Studies have shown high vulnerability of current power generation systems to increasing water temperature linked to climate change (Liu et al., 2017; Petrakopoulou et al., 2020). Recent events have shown that higher cooling water temperatures and/or inadequate water resources lead to reduced power plant capacity and could render many power plants uncompetitive (Kimmell and Veil, 2009; Peer and Sanders, 2018). In addition, thermal power plants are not attractive targets of water consumption reduction initiatives based on pricing alone (Lubega and Stillwell, 2019). The importance of less water-intensive energy systems and more effective regulations for water use in energy processes has been thereby recognized by many international organizations (IEA, 2016; U.S. Department of Energy, 2014; World Energy Council, 2016, 2010).

This paper aims to introduce an approach for assigning costs to qualitative and quantitative impacts of water exploitation – namely, temperature increase and reduced availability, – in power generation systems. Chemical contamination can be considered as an additional impact, however it is not considered here, as it would require a more complex treatment that is saved for future work. This study assumes that the long-term operation of a power plant affects the connected water resources and would therefore affect the future operation of the power plant in return. We, therefore, define worst-case scenarios under

maximum water exploitation applying theoretical qualitative and quantitative modifications of water properties, and then use these scenarios to estimate the impact they would have on power plant operation. Efficiency reductions due to increasing temperatures of cooling water and reduced water availability are then linked to power output reductions that represent an economic loss to the operation of the plant. To conceptualize the influence and weight of all studied parameters on the calculated costs, examples of two 400 MW plants operating with coal and natural gas (combined-cycle plants) are considered. The plants have a capacity factor of 85% (7446 h per year) and generate 2978 GWh of electricity per year. The adaptation of the methodology to other thermoelectric plants, including solar-thermal plants, is reserved for future work. Due to the global importance of the issue, the methodology also accounts for regional considerations (differentiation between water-abundant and water-stressed areas). The end result are generalized equations that aim to facilitate policy makers and energy experts to use the approach with minimal effort.

2. Methods

The analysis is realized in three steps, as visualized in Fig. 1. First, reference points of operation of natural gas and coal power plants with both once-through and wet-recirculating cooling systems are simulated in the software EpsilonProfessional (SteagEnergyServices, 2020). EpsilonProfessional is a commercial thermal

Table 1
Units of parameters and variables used in the equations.

	Units
EQQO	kW
f_{cons}	–
COE	€/MWh
c_w	kJ/kgK
\dot{m}	kg/s
η_{pp}	–
$T, \Delta T$	K
$\dot{W}, \Delta \dot{W}, \dot{Q}$	kW

engineering software used to simulate steady state and off-design behavior of thermal power plants. It includes common power plant components that can be used to simulate conventional power plants, nuclear, solar and wind power plants, desalination plants, fuel-cell applications, and user-specific processes.

First, to include regions with diverse climates, the simulations are realized for three ambient temperatures and seven cooling-water temperature ranges (reference conditions). Second, shifted points of operation are studied: the quality and quantity effects of changing water properties (i.e., cooling water temperature increase and mass flow rate decrease) on the operation of the power plants (note that the air temperature remains constant in the shifted points of operation and equal to that of the corresponding reference scenario). Penalties due to modified cooling water parameters are linked to reduced power output, relative to the reference conditions. Third, the economic loss related to the reduced power output is calculated. This expenditure, named cost of water impacts (COWI) is meant to be added onto any already existing base cost of water. The three steps of the methodology showing how to pass from the numerical simulations, realized for this purpose of this study, to general equations are described in more detail below. The units used in the parameters and variables of the equations are presented in Table 1.

Reference points of operation: water withdrawal and consumption. The simulations include coal and natural gas plants studied both with once-through and recirculating water-cooling systems. The flow diagrams of the plants are shown in the Appendix of the paper. Figs. A.1 and A.2 present the plants with closed-recirculated systems, while the plants with once-through cooling systems do not include cooling towers. Consider the simplified diagram of the cooling systems shown in Fig. 2, in which the steam exiting the steam turbine (Stream 1) is condensed (Stream 2; saturated water) and Streams 3 and 4 are the inlet and outlet streams of the cooling water. The simulations are realized for three ambient temperatures: 288.15 K, 293.15 K and 298.15 K. In each case, the operation of the condenser is studied as part of a once-through cooling system, as well as connected with a cooling tower (wet-recirculating cooling system). Furthermore, the condenser is considered to operate under seven cooling water temperature rise values (temperature difference between entering and exiting cooling water streams in the condenser, Streams 3 and 4 in Fig. 2, respectively): 3, 5, 7, 9, 11, 13 and 15 K. A higher cooling water temperature rise in the condenser (otherwise called cooling range of the cooling tower) corresponds to a higher exiting temperature of the cooling water (temperature of Stream 4). The reference simulations include thus a total of 84 scenarios. The default value of the temperature difference between the cooling water exiting the condenser and the steam exiting the steam turbine of the plant, i.e., the minimum temperature difference in the condenser (difference between Streams 1 and 4 of Fig. 2), is 4 K. For each simulation, the relative temperature increase of water exhausted to the environment and the quantity of water consumed resulting from the steady-state power plant operation are calculated. The stream results of the reference points with the

Table 2
Minimum and maximum temperatures of streams shown in Fig. 2 (derived from the numerical simulations of reference points of operation).

Stream no.	T_{min} [K]	T_{max} [K]
1	290.7	309.7
2	290.7	309.7
3		
<i>Once through</i>	283.7	290.7
<i>Wet recirculating</i>	286.8	295.4
4		
<i>Once through</i>	286.7	305.7
<i>Wet recirculating</i>	289.8	310.4
5	288.2	298.2
6	289.2	307.4
7	283.7	290.7
8	286.8	295.4

minimum and maximum temperature rise values (3 and 15 K) are presented in the Appendix of the paper. The minimum and maximum temperatures assumed for the streams of Fig. 2 at the reference points of operation are shown in Table 2.

The three ambient temperatures are applied to all air and fuel streams entering from the environment. The inlet temperature of the cooling water is calculated as 0.7 the temperature of the air (Morrill et al., 2005). The effect of the ambient temperature on the operation of the energy conversion systems is revealed in the numerical simulations and depends on (1) the cooling water system, (2) the type of fuel used and (3) the power plant technology implemented.

Increasing the air and water temperatures decreases the efficiency of the steam cycles of the plants: it increases the outlet temperature of the water (for a given condenser cooling water temperature rise) that in turn leads to a higher outlet pressure at the exit of the steam turbine (given a constant minimum temperature difference in the condenser). A higher pressure at the exit of the steam turbine results in decreased power output of the turbine that consequently decreases the overall efficiency of the facility. In closed-loop cooling systems, the temperature of the circulating water in the condenser depends on the wet bulb temperature of the ambient air, which is lower than its dry-bulb temperature. The temperature of the circulating water is thus lower than the air temperature. Moreover, higher ambient temperatures influence combined cycles more than coal plants, because they have a negative effect on the operation of the gas turbine system. Specifically, the reference point simulations realized in this work reveal an efficiency loss in the gas turbine of about 0.13% for every degree rise in air temperature. This is linked to a decrease of power output of 300–360 kW for each degree of air temperature increase.

Furthermore, higher values of the cooling water temperature rise in the condenser also lead to a higher outlet water temperature, which in turn leads to a higher outlet pressure at the exit of the steam turbine of the plants (constant minimum temperature difference in the condenser). Since this affects the steam cycle of the plant, it has a much lower effect on natural gas plants that only generate 1/3 of their power in the steam cycles. In this work, a decrease of approximately one percentage point in the efficiency of a coal power plant for a ten-degree increase in the cooling water temperature rise is found. The analogous result in natural gas plants is found to be negligible, i.e., one percentage point efficiency reduction for a thirty-degree increase in the temperature rise.

Shifted points of operation: effect of cooling water temperature rise and water availability. The simulations are here run again to study the effect of two issues on the operation of the power plants, relative to the reference simulations: (a) operation with higher cooling water inlet temperature (water quality effect)

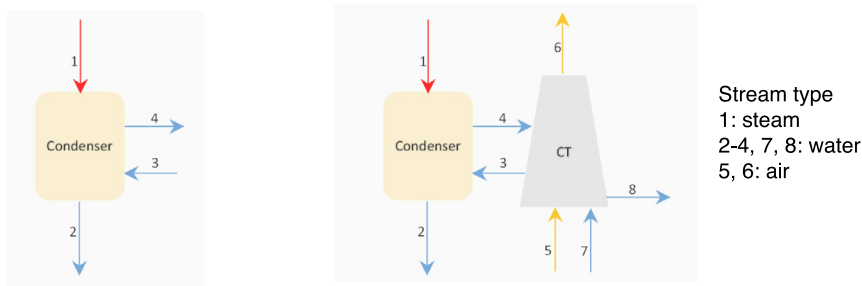

Fig. 2. Schematic design of once-through (left) and closed-recirculated (right) water cooling systems, where numbered streams are referred to in the text (CT: cooling tower). (For interpretation of the references to color in this figure legend, the reader is referred to the web version of this article.)

and (b) operation with insufficient water resources (water quantity effect). These scenarios result in 126 simulations.¹ Both of these changes of water characteristics are assumed to be caused by the operation of the power plant itself. The total water quality and quantity effect on power plant operation (EQQO) is then calculated summing up the individual water quality and quantity effects.

The **water quality effect** reflects the fact that elevated temperatures of return water flow from power plants will, over a long period of time, impact the quality of a water reserve. The extent of the impact of a plant on the water depends on the cooling technology employed, the capacity of the plant, as well as the size and other characteristics of the water source. The high-temperature water returned by a plant is mixed in the water source resulting in a moderate temperature overall. However, here, the aim is to account for the full impact of the plant on the water reserves, without accounting for external factors, like dilution effects based on environmental conditions or the size of the water resource. The shifted point of operation refers to the simulation that assumes elevated incoming cooling water (or make-up water) temperature equal to that of the outlet water temperature in the reference operation. The shifted point of operation in plants with once-through water cooling systems assumes cooling water inlet temperature equal to the water exhaust temperature of the reference point. For example, if the reference point of operation of a plant assumes a water return flow at 22°C, the shifted power plant operation sets the cooling water inlet temperature to 22 °C. The cooling water temperature rise and minimum temperature difference in the condenser are kept constant and equal to those of the reference case. Higher temperatures of cooling water force power plants to operate at reduced loads and result in lower efficiencies. The difference between the power output of reference and shifted points of operation constitutes the water quality effect of the plants. The effect of increasing the inlet temperature of cooling water in coal plants is expected to be higher than that in natural gas, since the latter generate only part of their electricity in the Rankine cycle.

In plants with wet-recirculating systems, the temperature of the exhaust water flow (blowdown, Stream 8 in Fig. 1) depends on the wet-bulb temperature of the air passing through the natural draft cooling tower (Stream 5). Since the shifted point of operation assumes variations in water inlet temperatures but constant air temperatures (the only variable in the water quality effect calculations is the temperature of the cooling water), the water quality effect is not calculated for plants with wet-recirculating cooling systems. As was the case with increasing ambient conditions, an increase in the inlet cooling water temperature in once-through systems leads to an increase in the exiting water temperature (assuming constant temperature rise

and minimum temperature difference in the condenser). This causes an increase in the outlet pressure of the steam turbine and reduces the power output and efficiency of the steam cycle. The qualitative power reduction relative to the reference simulation in plants with once-through systems is calculated as:

$$\begin{aligned}\Delta \dot{W}'_{qual} &= \dot{W}'_{ST,net} - \dot{W}'_{ST,net} = 3.83 \cdot \Delta T_{CW} \cdot (\dot{m}'_{CW} - \dot{m}_{CW}) \Rightarrow \\ \Delta \dot{W}'_{qual} &= 3.83 \cdot \Delta T_{CW} \cdot [(C_{fuel} \cdot \Delta T_{CW} + 1) \cdot \dot{m}_{CW} - \dot{m}_{CW}] \Rightarrow \\ \Delta \dot{W}'_{qual} &= 3.83 \cdot \Delta T_{CW} \cdot (C_{fuel} \cdot \Delta T_{CW} \cdot \dot{m}_{CW}) \Rightarrow \\ \Delta \dot{W}'_{qual} &= (B \cdot \Delta T_{CW}^2 \cdot \dot{m}_{CW})\end{aligned}\quad (1)$$

with $\dot{W}'_{ST,net}$ and $\dot{W}'_{ST,net}$ the steam turbine power output of the reference and shifted points of operation, respectively, ΔT_{CW} the cooling water temperature rise of the condenser, \dot{m}_{CW} and \dot{m}'_{CW} the cooling water mass flow of the reference and shifted points of operation, respectively, and B and C_{fuel} constants related to the type of fuel used. B and C_{fuel} are constants introduced to minimize the deviation of the generalized equations from the ensemble of numerical simulations. Combined they show the influence of ΔT_{CW} on the relative change of power output and cooling water mass flow. Parameter B is set here equal to 7.83×10^{-3} in coal and 9.41×10^{-3} in natural gas plants (based on numerical simulations). C_{fuel} is $2.04 \cdot 10^{-3}$ in coal and $2.46 \cdot 10^{-3}$ in natural gas plants. Two additional approximations used in the equations above are: $\frac{\dot{W}'_{tot,net} - \dot{W}_{tot,net}}{\dot{m}'_{CW} - \dot{m}_{CW}} = -3.83 \cdot \Delta T_{CW}$ and $\dot{m}'_{CW} \approx (C_{fuel} \cdot \Delta T_{CW} + 1) \cdot \dot{m}_{CW}$.

The mass flow of circulating water flowing through the condenser (equal to the water withdrawn in once-through systems) can be calculated as follows:

$$\dot{m}_{CW} = \frac{\dot{W}_{net} (1 - A - \eta_{PP})}{\eta_{PP} \cdot c_w \cdot \Delta T_{CW}} \quad [\text{in kg/s}] \quad (2)$$

with, c_w the specific heat capacity of water, η_{PP} the efficiency of the power plant and \dot{W}_{net} the net power output of the plant. A is a constant that represents the percentage of the energy of the fuel lost through the exhaust gases of the plant and depends on the type of fuel used in the plant. With appropriate tuning and for the purpose of this work, the values of $A = 0.12$ for coal plants and $A = 0.24$ for natural gas plants are used.

Eq. (2) is derived using the definition of the mass flow of circulating water in the condenser as:

$$\dot{m}_{CW} = \frac{\dot{Q}_{CW}}{c_w \cdot \Delta T_{CW}} \quad (3)$$

where, \dot{Q}_{CW} is the amount of thermal energy extracted using cooling water.

The overall energy balance of the plant is: $\dot{Q}_{CW} = \dot{Q}_F - \dot{Q}_L - \dot{W}_{net}$, where, \dot{Q}_F is the thermal energy input, i.e., the fuel of the plant and \dot{Q}_L is the thermal energy lost through the flue gas exhaust. It is assumed that the thermal energy lost through the

¹ The water quality effect for plants with wet-recirculating cooling systems is not calculated (see below for further explanation).

flue gas exhaust is some part A of the fuel input: $\dot{Q}_L = \dot{m}_{fg} h_{fg} = A \cdot \dot{Q}_F$. Thus: $\dot{Q}_{CW} = \dot{Q}_F - A \cdot \dot{Q}_F - \dot{W}_{net} = (1 - A) \dot{Q}_F - \dot{W}_{net}$.

Accounting for the fact that the thermal energy input through the fuel is equal to the ratio of net electricity generation over the efficiency of the power plant (η_{PP}), $\dot{Q}_F = \frac{\dot{W}_{net}}{\eta_{PP}}$, it is found that:

$$\dot{Q}_{CW} = (1 - A) \left(\frac{\dot{W}_{net}}{\eta_{PP}} \right) - \dot{W}_{net} = \dot{W}_{net} \left[\frac{(1 - A)}{\eta_{PP}} - 1 \right] \quad (4)$$

Eq. (2) is subsequently obtained by substituting Eq. (4) into Eq. (3).

The **water quantity (quant) effect** is based on the fact that thermal power plant operation consumes large amounts of water that are not recuperated, preventing their downstream use. Water losses from cooling systems mainly stem from evaporation. Water evaporation requires continuous make-up water flows from a water source. This repercussion of the operation of the power plants may further accentuate water availability issues, affecting the global water cycle. Scarce water resources have a direct impact on the operation of the power plants, forcing them to operate at decreased capacity and may even render their operation as non-viable in the energy market.

The water quantity effect is defined for both once-through and wet-recirculating systems. It is here estimated by decreasing the cooling water mass flow of the simulation (water withdrawn in once-through systems or water recycled in closed-loop systems) by the total amount of water consumed in the reference case. In these cases, zero make-up water is assumed, while all other operational conditions are kept constant. Forcing the condenser of the plants to operate with smaller mass flow rates of cooling water reduces the thermal extraction capacity of the Rankine cycle and has a direct effect on the power output. The difference between the power output of reference and shifted points of operation constitutes the water quantity effect of the plants. Although wet-recirculating cooling systems withdraw much smaller amounts of water than once-through systems, they consume relatively larger quantities of water due to more significant evaporation losses in the cooling tower (Luo et al., 2018).

The water quantity effect is calculated with equations incorporated into the simulations using the programming language interface of EpsilonProfessional. In all cases, a linear relationship between the power output of the steam cycle and the circulating water flowing through the condenser is assumed. For coal power plants the net power output is that of the steam turbines $\dot{W}_{quant} = E \cdot \dot{W}_{ST}$, while for combined-cycle power plants, it is the sum of the power output of the gas (\dot{W}_{quant_GT}) and steam turbines: $\dot{W}_{quant} = \dot{W}_{GT,net} + (E \cdot \dot{W}_{ST,net})$. Parameter E represents the ratio by which the theoretically decreased water amount would reduce the power output of the steam turbine, when compared to the reference point of operation:

$$E = \frac{(\dot{m}_{CW} - \dot{m}_{CW_MU})}{\dot{m}_{CW}} \quad (5)$$

where, \dot{m}_{CW} is the mass flow rate of the circulating water in the condenser in the simulation (withdrawn in once-through systems and recycled in cooling towers) and \dot{m}_{CW_MU} is the mass flow rate of water lost due to evaporation in the shifted point of operation (due to increased inlet water temperature). If not known, the mass flow rate \dot{m}_{CW} (kg/s) of the cooling water passing through the condenser can be approximated using Eq. (2).

In power plants with once-through systems, parameter E of the shifted point of operation is more accurately defined as: $\frac{\dot{m}'_{CW} - (\dot{m}'_{CW} \cdot f_{cons})}{\dot{m}'_{CW}}$. The power output in this case, is thus calculated as:

$$\dot{W}'_{ST,net} = \frac{\dot{m}'_{CW} - (\dot{m}'_{CW} \cdot f_{cons})}{\dot{m}'_{CW}} \dot{W}'_{ST,net} = (1 - f_{cons}) \cdot \dot{W}'_{ST,net} \quad (6)$$

with, f_{cons} the percentage of water consumed/lost in the plant, $\dot{W}'_{ST,net}$ the net power output of the steam turbine in the shifted point of operation (with increased inlet cooling water temperature) and $\dot{W}''_{ST,net}$ the net power output of the steam turbine in the shifted point of operation (also with decreased water availability).

Thus, the quantitative reduction in power output is:

$$\begin{aligned} \Delta \dot{W}'_{quant} &= \dot{W}_{ST,net} - \dot{W}''_{ST,net} = \dot{W}_{ST,net} - (1 - f_{cons}) \cdot \dot{W}'_{ST,net} \Rightarrow \\ \Delta \dot{W}'_{quant} &= B \cdot \Delta T_{CW}^2 \cdot \dot{m}_{CW} (1 - f_{cons}) + (f_{cons} \cdot \dot{W}_{ST,net}) \end{aligned} \quad (7)$$

with, the product $\dot{m}_{CW} \cdot f_{cons}$ representing the total amount of water consumed. Thus, the total of quality and quantity effect of water use on power plant operation (EQQO) with once-through water cooling system is:

$$\begin{aligned} EQQO^{once} &= \Delta \dot{W}'_{quant} + \Delta \dot{W}'_{qual} \\ &= B \cdot \Delta T_{CW}^2 \cdot \dot{m}_{CW} (2 - f_{cons}) + (f_{cons} \cdot \dot{W}_{ST,net}) \end{aligned} \quad (8)$$

In the case of wet-recirculating water-cooling systems, the make-up water balances the blowdown loss (related to water in the air used in the cooling tower) and the drift loss fraction (related to the recirculating water stream). To estimate the water quantity effect, the $\dot{W}'_{ST,net}$ is defined as follows:

$$\dot{W}'_{ST,net} = \frac{\dot{m}_{CW} - \dot{m}'_{MU}}{\dot{m}_{CW}} \dot{W}_{ST,net} = \left[1 - \frac{\dot{m}'_{MU}}{\dot{m}_{CW}} \right] \cdot \dot{W}_{ST,net} \quad (9)$$

In this case, the error is small, allowing the assumption that the differences between the make-up water flows of the reference and shifted simulations are negligible: $\dot{m}_{MU} = \dot{m}'_{MU}$. Thus, assuming that $\dot{m}'_{MU} = (1 + 0.0015 \cdot \Delta T_{CW}) \cdot \dot{m}_{MU}$ and $\dot{m}_{MU} = (1.35 \cdot 10^{-3} \cdot \Delta T_{CW} + 0.012)$, it is derived that $\dot{m}'_{MU} = (1.35 \cdot 10^{-3} \cdot \Delta T_{CW} + 0.012) \cdot \dot{m}_{CW}$. The quantitative power effect is then found to be $(\dot{W}_{ST,net} - \dot{W}'_{ST,net})$:

$$\Delta \dot{W}'_{quant} = \frac{\dot{m}'_{MU}}{\dot{m}_{CW}} \cdot \dot{W}_{ST,net} = (1.35 \cdot 10^{-3} \cdot \Delta T_{CW} + 0.012) \cdot \dot{W}_{ST,net} \quad (10)$$

The EQQO when wet-recirculating water-cooling systems are used (labeled with CT) is thus equal to the quantitative power effect:

$$EQQO^{CT} = \Delta \dot{W}'_{quant} = (1.35 \cdot 10^{-3} \cdot \Delta T_{CW} + 0.012) \cdot \dot{W}_{ST,net} \quad (11)$$

The cost of water impacts, COWI. What defined here as the cost of water impacts (COWI) is based on known or easily estimated operational parameters. The power reduction at the shifted points of operation (with higher temperature or unavailability of cooling water) is herewith linked to an economic expenditure. COWI is based on mathematical expressions of power plant operation and it is formulated using the results of the detailed numerical simulations presented above. In essence, the COWI represents the economic loss of a plant from electricity that would be lost under new background conditions (shifted points of operation) that account for the power plant's impact on the water resource. The multiplication of EQQO with the appropriate (regional) levelized cost of electricity (COE) represents the theoretical economic loss of the plant from electricity lost, i.e., not sold in the market due to imposed (theoretical) deterioration of the water resource. COWI needs to be added to any already existing base cost of water and can be imposed on the plant as a penalty for water use, i.e., it provides the cost of water impacts for a more just reflection of water use in the markets.

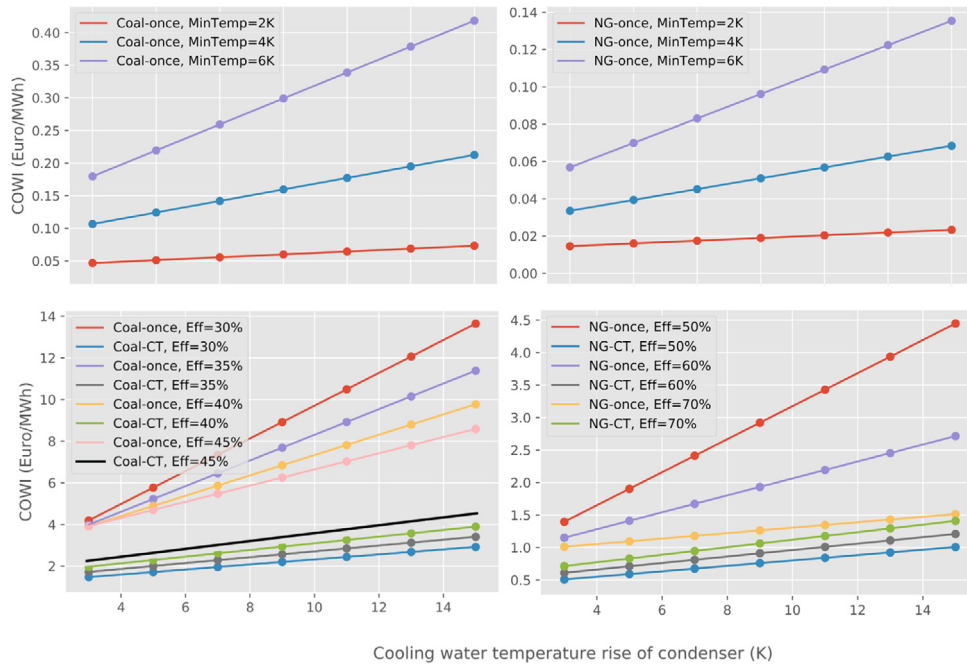

Fig. 3. Variation of the COWI as a function of the cooling water temperature rise, with different minimum temperatures in the condenser (top panels) and power plant efficiency (bottom panels). Left panels refer to coal plants and right panels to natural gas plants. Note the different ranges in the vertical axes (the figures are based on the general equations that are independent of the inlet ambient temperature).

COWI is calculated as:

$$COWI = \frac{COE}{\dot{W}_{in,tot}} \cdot f_{ws} \cdot EQQO \quad [€/MWh] \quad (12)$$

where, *COE* is the levelized cost of electricity and $\dot{W}_{in,tot}$ is the net power output of the reference point of operation of the plant. f_{ws} is a simple water scarcity factor extracted from linking the ratio of freshwater withdrawal to available flow (WTA) (Zhang et al., 2018). The water scarcity factor is introduced as an additional scaling of the impact of the power plant operation onto the environment. This factor accounts for the fact that a more vulnerable environment (with a high water scarcity factor) will be affected more severely by the operation of the plant. Overall higher values of COWI, due to higher power reduction and higher revenue loss, show a stronger effect of power plant operation on water resources and, vice versa, a stronger impact of water restrictions to the operation of the power plant.

Eqs. (8) and (11) are generalized equations that can be used for the calculation of COWI (Eq. (12)) of similarly operating power plants.

3. Results

3.1. Effect of operational conditions on the COWI: efficiency, temperature rise and minimum temperature difference in the condenser

The basic parameters used in the reference points of operation and the general equations presented above are shown in Table 3.

The main parameter affecting the COWI is the temperature increase of the cooling water in the condenser, i.e., the cooling water temperature rise of the condenser. The relationship between the COWI and the temperature rise is linear (see Fig. 3). A higher temperature rise will lead to an increase of the outlet pressure of the steam turbine (to keep the minimum temperature difference in the condenser fixed) and will subsequently cause a significant decrease in the power output of the plant. Furthermore, although a plant with a higher temperature rise

Table 3

Basic parameters of general equations (efficiencies derived from the numerical simulations of reference points of operation).

Natural gas plant efficiency	54%
Relative power output (steam over gas turbines in the combined cycle)	31%
Coal plant efficiency	36%
Water consumed in once-through cooling (f_{cons})	0.02 (2% of the water flows through condenser)
Water stress factor	Six categories from 1 to 6. 1 for low WTA ratio (<0.1), 2 for low to medium (0.1–0.2), 3 for medium to high (0.2–0.4), 4 for high (0.4–0.8), 5 for extremely high (>0.8) and 6 for arid and low water use (defined for areas with available blue water and water withdrawal of less than 0.03 and 0.012 m ³ m ⁻² yr ⁻¹ , respectively).

allows the use of less cooling water, it may cause an overall higher quality impact on the water resource due to the higher exhaust temperature of the water used.

The influence of the cooling water temperature rise on the COWI is found to be significantly stronger in the case of power plants with once-through cooling systems and coal plants. Overall, an approximately threefold increase in the COWI for a fivefold increase in the cooling water temperature rise of the condenser is estimated (modified from 3 to 15 K). Specifically, the COWI for power plants with once-through cooling water systems is estimated to be between 3.94 and 4.03 €/MWh in coal and between 1.26 and 1.33 €/MWh in natural gas plants (varies with varying water inlet temperature), when the temperature rise increase is 3 K, while it is close to three times higher for a temperature rise of 15 K (11.19–11.45 €/MWh for coal and 3.66–3.87 €/MWh for natural gas plants, respectively). This implies an increase of more than 0.6 and 0.2 €/MWh per degree of increase of water return temperature for coal and natural gas plant, respectively.

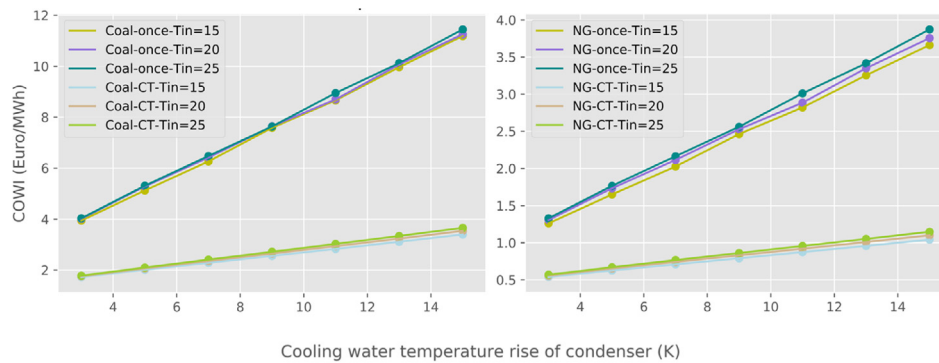

Fig. 4. Variation of the COWI with cooling water temperature rise and air temperature (T_{in}) in coal (left panel) and natural gas plants (right panel) with wet-recirculating (CT) and once-through (once) cooling water systems (assuming default $T_{min} = 4K$).

Two other important parameters in the calculation of the COWI, are the minimum temperature difference in the condenser and the operational efficiency of the plants.

The minimum temperature difference in the condenser affects the outlet pressure of the steam turbine. In this way, a smaller minimum temperature difference in the condenser could dissipate part of the effect of the variation of the cooling water temperature rise has on the outlet pressure of the steam turbine. This effect is only accounted for in power plants with once-through systems. In plants with closed-recirculating water systems, the effect was found to be negligible. In this case, the effect depends on the ratio between the make-up and cooling water mass flow rates and the power output of the plant (see Eq. (10) of Methods). If constant power output is assumed, the variation of the ratio of the two mass flow rates is minimal. For example, if a lower minimum temperature difference is allowed in the condenser, a higher outlet temperature of the cooling water is automatically allowed. This larger increase in water temperature would mean a decrease in the required circulating cooling water in the condenser and a lower make-up water flow. Thus, it is assumed that the EQQO of plants with wet-recirculating cooling systems remains unaffected. As shown in Fig. 3, the COWI increases with increasing cooling water temperature rise of the condenser. Small minimum temperature differences decrease the effect of cooling water temperature rise variations on the calculated COWI (the slope becomes less steep, and the lines converge for a smaller temperature rise).

The variation of the efficiency of the plants has a similar effect on the calculated COWI as the minimum temperature difference. The effect of the cooling water temperature rise decreases with increasing overall efficiency (slope becomes less steep). The slope for plants with wet-recirculating systems is independent from the efficiency of the plant. The relative effect of a change in the temperature rise in a plant will thus be practically similar in two plants with different efficiencies. A change in the operational efficiency in plants will cause the same change in the mass flow rate of cooling water in plants independent of their cooling system. In plants with once-through systems, however, this would imply a direct increase of their quality and quantity impact and, consequently, EQQO. As mentioned previously, in plants with wet-recirculating systems, the EQQO depends on the ratio between the make-up and cooling water mass flow rate and the power output of the plant and it can be considered practically negligible. The total effect of the cooling water mass flow in the case of plants with recirculating systems is thus lower. If the 2015 reported COE of UAE and Germany (90 and 150 E/MWh) is assumed, for example, a COWI 67% higher for Germany than for UAE is found (Statista, 2018).

3.2. Effect of cooling water inlet temperature on the COWI

Fig. 4 shows the COWI of coal and natural gas plants with once-through and wet-recirculating systems with varying inlet water temperature and cooling water temperature rise. The COWI (Eq. (12)) depends on the ratio $\frac{EQQO_{once/CT}}{W_{in,tot}}$. Increasing the inlet water temperature thus decreases the efficiency that in turn increases the COWI (Fig. 4). However, it is seen that this single change does not result in notable changes. It should be noted that if the shifted points of operation accounted for the variation of all ambient streams (including the air temperature), the effect on the operation of the power plants would be much stronger. However, it was intentionally chosen to account solely for the effect of the water temperature on the operation of the plant and to not include other byproducts of what could be considered potential climatic change impacts. Since our simulations show that the effect of the variation of the inlet temperature of the cooling water is rather small, it is not accounted for in the general equations.

3.3. Effect of regional factors on the COWI: cost of electricity and water stress

Two parameters that influence the calculated COWI significantly are the COE and the water stress factor. The specific effect of the variation of these two parameters can be seen in Fig. 5. The variation of the COWI is of the same order of magnitude as the variations of COE and water scarcity factor. For example, doubling the COE or water stress factor will cause a doubling of the COWI. The relationship between coal and natural gas plants remains unchanged, with coal resulting in approximately three times higher COWI than natural gas plants. The same is true for the relationship between plants with open loop and wet-recirculating systems.

The two parameters studied here depend on regional regulations and they provide a better representation of regional conditions when considered together. Fig. 5 shows the variation of the levelized COE in the range of 90–150 €/MWh. When also accounting, however, for the water stress of each region, the results change. According to the World Resources Institute (Gassert et al., 2013), Germany is characterized with a water stress factor of 3 (numbering accounting for an additional initial level (Statista, 2018)), while the UAE is linked with the maximum stress factor of 6. The combination of both the COE and WS would result in an overall 20% higher COWI for UAE, when compared to Germany. Two regions with equal ratios of COE and water stress factors will have equal COWI.

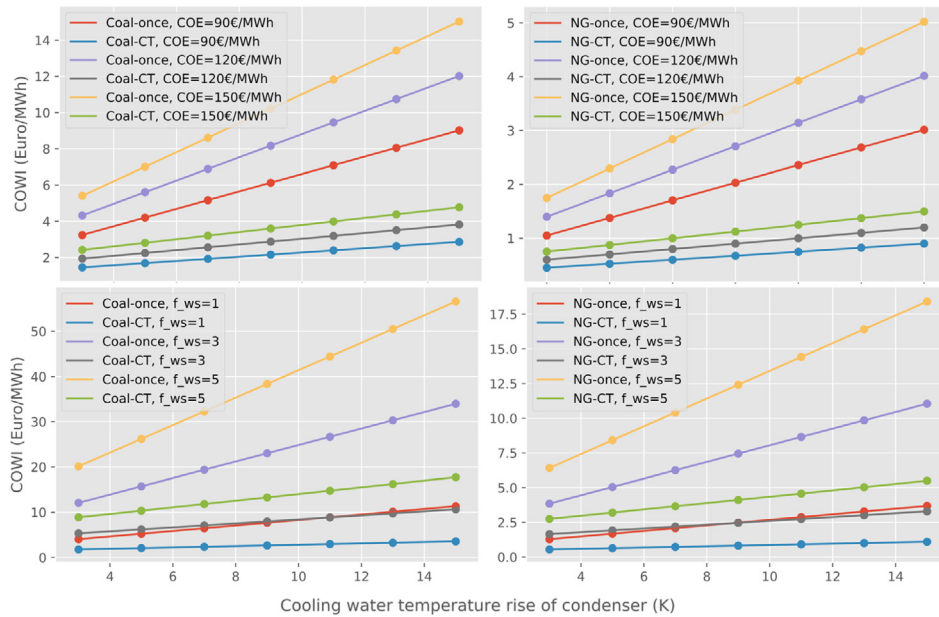

Fig. 5. Variation of the COWI with assumed COE (top panels) water stress factor (bottom panels) and cooling water temperature rise. Left panels refer to coal plants and right panels to natural gas plants (the figures are based on the general equations that are independent of the inlet ambient temperature and assume default $T_{min} = 4K$).

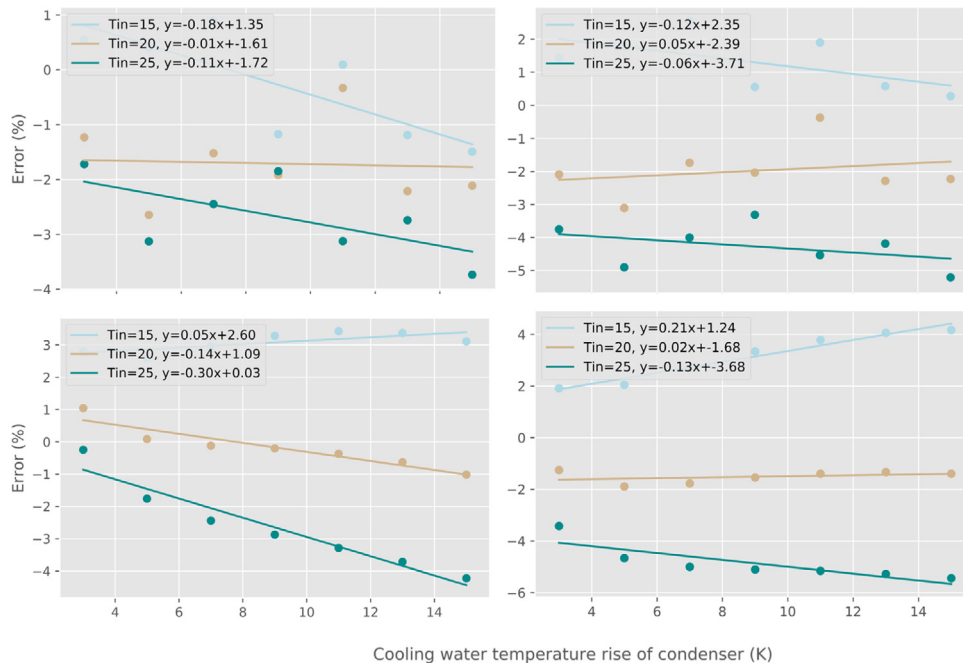

Fig. 6. Graphical representation of the errors of the generalized equations relative to the analytical numerical simulations, including linear fits to aid comparison. Plants with once-through water-cooling systems are shown in the top panels and plants with wet-recirculating systems in the bottom panels. Left panels refer to coal and right panels to natural gas plants.

4. Error analysis of the mathematical simplification of the generalized equations

The generalized equations, Eqs. (8), (11) and (12), approximate the results of the ensemble of detailed simulations of coal and natural gas plants, and are thus subject to error quantified here (Fig. 6). Fig. 6 is based on a reference inlet ambient temperature (air and fuel) equal to 20 °C. As seen, the magnitude of the error of the general equations increases for higher cooling water temperature rise of the condenser and inlet temperatures of the cooling water.

The error analysis results in lower values when the ambient temperature is lower and it is also kept at lower levels for coal plants, when compared to natural gas plants. Nonetheless, the error between the general equations and the real numerical results is not seen to surpass 6% in any case.

5. Conclusion

Our methodology defines the COWI, the cost of water impacts that can incentivize the more sustainable and responsible use

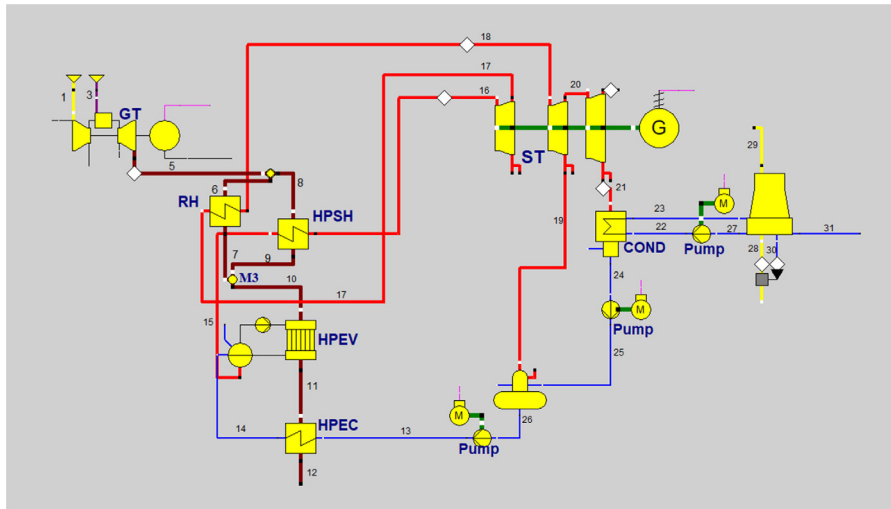

Fig. A.1. Flow diagram of the natural gas plant.

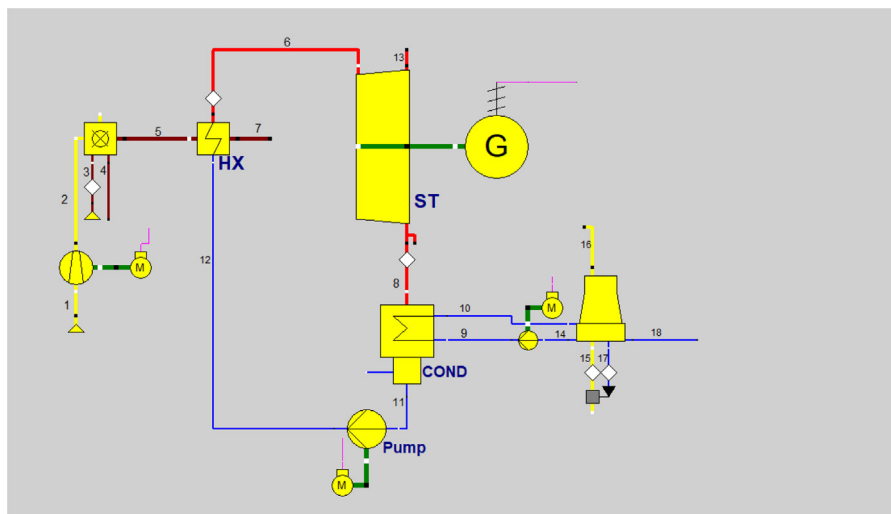

Fig. A.2. Flow diagram of the coal plant.

Table A.1

Stream results for the coal plants with ambient temperatures 15, 20 and 25 °C with wet-recirculating (columns marked green) and once-through (columns marked orange) cooling systems. The temperature rise in the condenser is 3K.

Stream	Mass [kg/s]	Temperature [°C]	Pressure [bar]	Mass [kg/s]	Temperature [°C]	Pressure [bar]	Mass [kg/s]	Temperature [°C]	Pressure [bar]	Mass [kg/s]	Temperature [°C]	Pressure [bar]	Mass [kg/s]	Temperature [°C]	Pressure [bar]	Mass [kg/s]	Temperature [°C]	Pressure [bar]
1	519.18	15.00	1.01	509.59	20.00	1.01	500.11	25.00	1.01	519.18	15.00	1.01	509.59	20.00	1.01	500.11	25.00	1.01
2	519.18	15.26	1.02	509.59	20.36	1.02	500.11	25.27	1.02	519.18	15.26	1.02	509.59	20.36	1.02	500.11	25.27	1.02
3	35.54	15.00	1.02	35.79	20.00	1.02	36.07	25.00	1.02	35.54	15.00	1.02	35.79	20.00	1.02	36.07	25.00	1.02
4	0.00	0.00	1.02	0.00	0.00	1.02	0.00	0.00	1.02	0.00	0.00	1.02	0.00	0.00	1.02	0.00	0.00	1.02
5	554.72	1649.58	1.01	545.39	1689.07	1.01	536.18	1721.30	1.01	554.72	1649.58	1.01	545.39	1689.07	1.01	536.18	1721.30	1.01
6	290.87	560.00	210.00	296.14	560.00	210.00	301.70	560.00	210.00	290.87	560.00	210.00	296.14	560.00	210.00	299.87	560.00	210.00
7	554.72	205.00	1.01	545.39	205.00	1.01	536.18	205.00	1.01	554.72	205.00	1.01	545.39	205.00	1.01	536.18	205.00	1.01
8	290.87	20.41	0.02	296.14	24.90	0.03	301.70	29.39	0.04	290.87	17.50	0.02	294.70	21.08	0.03	299.87	24.63	0.03
9	43935.18	13.61	1.06	44912.60	17.93	1.06	45924.77	22.25	1.06	43624.86	10.50	1.01	44521.91	14.00	1.01	45449.26	17.50	1.01
10	43935.18	16.61	1.01	44912.60	20.93	1.01	45924.77	25.25	1.01	43624.86	13.50	1.01	44521.91	17.00	1.01	45449.26	20.50	1.01
11	290.87	20.41	0.02	296.14	24.90	0.03	301.70	29.39	0.04	290.87	17.50	0.02	294.70	21.08	0.03	299.87	24.63	0.03
12	290.87	22.11	221.05	296.14	26.66	221.05	301.70	31.23	221.05	290.87	19.14	221.05	294.70	22.78	221.05	299.87	26.39	221.05
13	0.00	20.41	0.02	0.00	24.90	0.03	0.00	29.39	0.04									
14	43935.18	13.61	1.01	44912.60	17.93	1.01	45924.77	22.25	1.01									
15	40421.93	15.00	1.01	35111.88	20.00	1.01	30239.41	25.00	1.01									
16	40688.74	16.01	1.01	35376.11	20.33	1.01	30518.47	24.65	1.01									
17	686.16	10.50	1.01	713.35	14.00	1.01	738.31	17.50	1.01									
18	439.35	13.61	1.01	449.13	17.93	1.01	459.25	22.25	1.01									

of water resources in the energy sector. The extent of the estimated cost depends on basic operational characteristics of the studied power plant. Our calculations, considering the default values shown in Table 3 of Methods, show that the COWI can significantly increase the annual costs of a plant. To conceptualize

and weigh the influence of all studied parameters on the calculated costs, an example of two 400 MW plants operating with coal and natural gas, respectively, both with a capacity factor of 85% (7446 h per year) and electricity generation of 2978 GWh per year has been considered. It should be mentioned that the calculated costs would change significantly for a different set of

Table A.2

Stream results for the coal plants with ambient temperatures 15, 20 and 25°C with wet-recirculating (columns marked green) and once-through (columns marked orange) cooling systems. The temperature rise in the condenser is 15K.

Stream	Mass [kg/s]	Temperature [°C]	Pressure [bar]	Mass [kg/s]	Temperature [°C]	Pressure [bar]	Mass [kg/s]	Temperature [°C]	Pressure [bar]	Mass [kg/s]	Temperature [°C]	Pressure [bar]	Mass [kg/s]	Temperature [°C]	Pressure [bar]	Mass [kg/s]	Temperature [°C]	Pressure [bar]			
1	519.18	15.00	1.01	509.59	20.00	1.01	519.18	15.00	1.01	509.59	20.00	1.01	519.18	15.00	1.01	509.59	20.00	1.01	519.18	15.00	1.01
2	519.18	15.26	1.02	509.59	20.26	1.02	519.18	15.26	1.02	509.59	20.26	1.02	519.18	15.26	1.02	509.59	20.26	1.02	519.18	15.26	1.02
3	36.64	15.00	1.02	36.87	20.00	1.02	37.14	15.00	1.02	36.64	15.00	1.02	36.87	20.00	1.02	37.14	15.00	1.02	36.64	15.00	1.02
4	0.00	0.00	0.00	0.00	0.00	0.00	0.00	0.00	0.00	0.00	0.00	0.00	0.00	0.00	0.00	0.00	0.00	0.00	0.00	0.00	0.00
5	558.82	1691.23	1.01	546.46	1726.28	1.01	537.25	1762.62	1.01	558.82	1691.23	1.01	546.46	1726.28	1.01	537.25	1762.62	1.01	558.82	1691.23	1.01
6	305.61	560.00	210.00	310.66	560.00	210.00	316.29	560.00	210.00	304.32	560.00	210.00	309.13	560.00	210.00	314.32	560.00	210.00	305.61	560.00	210.00
7	558.82	205.00	1.01	546.46	205.00	1.01	537.25	205.00	1.01	558.82	205.00	1.01	546.46	205.00	1.01	537.25	205.00	1.01	558.82	205.00	1.01
8	305.61	32.88	0.05	310.66	36.91	0.06	316.29	41.27	0.08	304.32	29.60	0.04	309.13	33.09	0.05	314.32	36.46	0.06	305.61	32.88	0.05
9	9317.71	13.61	1.06	9501.14	17.93	1.06	9702.15	22.25	1.06	9252.88	10.50	1.01	9426.27	14.00	1.01	9609.10	17.50	1.01	9317.71	13.61	1.06
10	9317.71	38.61	1.01	9501.14	42.93	1.01	9702.15	47.25	1.01	9252.88	25.50	1.01	9426.27	29.00	1.01	9609.10	35.50	1.01	9317.71	38.61	1.01
11	305.61	32.88	0.05	310.66	36.91	0.06	316.29	41.27	0.08	304.32	29.60	0.04	309.13	33.09	0.05	314.32	36.46	0.06	305.61	32.88	0.05
12	305.61	34.77	221.05	310.66	38.86	221.05	316.29	43.29	221.05	304.32	31.44	221.05	309.13	34.98	221.05	314.32	38.41	221.05	305.61	34.77	221.05
13	0.00	0.00	0.00	0.00	0.00	0.00	0.00	0.00	0.00	0.00	0.00	0.00	0.00	0.00	0.00	0.00	0.00	0.00	0.00	0.00	0.00
14	9317.71	13.61	1.01	9501.14	17.93	1.01	9702.15	22.25	1.01	9252.88	10.50	1.01	9426.27	14.00	1.01	9609.10	17.50	1.01	9317.71	13.61	1.01
15	12410.20	15.00	1.01	10655.35	20.00	1.01	10994.78	25.00	1.01	10259.26	15.00	1.01	10597.33	20.00	1.01	10933.29	24.25	1.01	12410.20	15.00	1.01
16	12599.26	25.61	1.01	10859.75	29.93	1.01	11133.29	34.25	1.01	10259.26	15.00	1.01	10597.33	20.00	1.01	10933.29	24.25	1.01	12599.26	25.61	1.01
17	282.24	10.50	1.01	299.42	14.00	1.01	315.65	17.50	1.01	282.24	10.50	1.01	299.42	14.00	1.01	315.65	17.50	1.01	282.24	10.50	1.01
18	93.18	13.61	1.01	95.01	17.93	1.01	97.02	22.25	1.01	93.18	13.61	1.01	95.01	17.93	1.01	97.02	22.25	1.01	93.18	13.61	1.01

Table A.3

Stream results for the natural gas plants with ambient temperatures 15, 20 and 25 °C with wet-recirculating (columns marked green) and once-through (columns marked orange) cooling systems. The temperature rise in the condenser is 3K.

Stream no.	Mass [kg/s]	Temperature [°C]	Pressure [bar]	Mass [kg/s]	Temperature [°C]	Pressure [bar]	Mass [kg/s]	Temperature [°C]	Pressure [bar]	Mass [kg/s]	Temperature [°C]	Pressure [bar]	Mass [kg/s]	Temperature [°C]	Pressure [bar]	Mass [kg/s]	Temperature [°C]	Pressure [bar]				
1	627.68	15.00	1.01	619.16	20.00	1.01	613.85	25.00	1.01	627.68	15.00	1.01	619.16	20.00	1.01	613.85	25.00	1.01	627.68	15.00	1.01	
2	0.00	223.54	5.50	0.00	223.54	5.50	0.00	223.54	5.50	0.00	223.54	5.50	0.00	223.54	5.50	0.00	223.54	5.50	0.00	223.54	5.50	0.00
3	14.75	15.00	20.00	14.74	20.00	20.00	14.75	25.00	20.00	14.75	15.00	20.00	14.74	20.00	20.00	14.76	25.00	20.00	14.75	15.00	20.00	
4	0.00	13.00	0.00	0.00	13.00	0.00	0.00	13.00	0.00	0.00	13.00	0.00	0.00	13.00	0.00	0.00	13.00	0.00	0.00	13.00	0.00	0.00
5	642.43	618.52	1.03	633.90	629.48	1.03	628.61	638.23	1.03	642.43	618.52	1.03	633.90	629.48	1.03	628.61	638.23	1.03	642.43	618.52	1.03	
6	321.22	536.51	1.02	316.95	544.30	1.02	314.30	550.52	1.02	321.22	536.51	1.02	316.95	544.30	1.02	314.30	550.52	1.02	321.22	536.51	1.02	
7	321.22	618.52	1.03	316.95	629.48	1.03	314.30	638.23	1.03	321.22	618.52	1.03	316.95	629.48	1.03	314.30	638.23	1.03	321.22	618.52	1.03	
8	321.22	423.42	1.02	316.95	436.75	1.02	314.30	449.41	1.02	321.22	423.42	1.02	316.95	436.75	1.02	314.30	449.41	1.02	321.22	423.42	1.02	
9	642.43	480.35	1.02	633.90	485.94	1.02	628.61	490.40	1.02	642.43	480.35	1.02	633.90	485.94	1.02	628.61	490.40	1.02	642.43	480.35	1.02	
10	642.43	341.18	1.02	633.90	341.18	1.02	628.61	341.18	1.02	642.43	341.18	1.02	633.90	341.18	1.02	628.61	341.18	1.02	642.43	341.18	1.02	
11	642.43	231.66	1.01	633.90	227.12	1.01	628.61	223.49	1.01	642.43	231.66	1.01	633.90	227.12	1.01	628.61	223.49	1.01	642.43	231.66	1.01	
12	642.43	140.04	134.56	88.76	140.04	134.56	88.76	140.04	134.56	88.76	140.04	134.56	88.76	140.04	134.56	88.76	140.04	134.56	88.76	140.04	134.56	88.76
13	86.37	325.17	130.53	88.76	325.17	130.53	88.76	325.17	130.53	88.76	325.17	130.53	88.76	325.17	130.53	88.76	325.17	130.53	88.76	325.17	130.53	88.76
14	86.37	331.17	130.53	88.76	331.17	130.53	88.76	331.17	130.53	88.76	331.17	130.53	88.76	331.17	130.53	88.76	331.17	130.53	88.76	331.17	130.53	88.76
15	86.37	360.00	124.00	88.76	360.00	124.00	88.76	360.00	124.00	88.76	360.00	124.00	88.76	360.00	124.00	88.76	360.00	124.00	88.76	360.00	124.00	88.76
16	86.37	407.72	47.37	88.76	407.72	47.37	88.76	407.72	47.37	88.76	407.72	47.37	88.76	407.72	47.37	88.76	407.72	47.37	88.76	407.72	47.37	88.76
17	86.37	560.00	45.00	88.76	560.00	45.00	88.76	560.00	45.00	88.76	560.00	45.00	88.76	560.00	45.00	88.76	560.00	45.00	88.76	560.00	45.00	88.76
18	15.01	232.59	4.10	14.94	232.59	4.10	14.78	232.59	4.10	15.31	232.59	4.10	15.35	232.59	4.10	15.32	232.59	4.10	15.01	232.59	4.10	14.94
19	71.36	232.59	4.10	73.83	232.59	4.10	76.05	232.59	4.10	71.06	232.59	4.10	73.41	232.59	4.10	75.52	232.59	4.10	71.36	232.59	4.10	73.83
20	71.36	20.41	0.02	73.83	24.90	0.03	76.05	29.39	0.04	71.06	17.50	0.02	73.41	21.08	0.03	75.52	24.63	0.03	71.36	20.41	0.02	73.83
21	12204.26	13.61	1.05	12688.33	17.93	1.05	13131.26	22.25	1.05	12104.89	10.50	1.01	12559.57	14.00	1.01	12971.09	17.50	1.01	12204.26	13.61	1.05	12688.33
22	12204.26	38.61	1.01	12688.33	42.93	1.01	13131.26	47.25	1.01	12104.89	25.50	1.01	12559.57	29.00	1.01	12971.09	35.50	1.01	12204.26	38.61	1.01	12688.33
23	71.36	20.41	0.02	73.83	24.90	0.03	76.05	29.39	0.04	71.06	17.50	0.02	73.41	21.08	0.03	75.52	24.63	0.03	71.36	20.41	0.02	73.83
24	71.36	20.43	3.40	73.83	24.91	3.40	76.05	29.40	3.40	71.06	17.51	3.40	73.41	21.09	3.40	75.52	24.64	3.40	71.36	20.43	3.40	73.83
25	86.37	423.42	3.40	88.76	423.85	3.40	89.84	423.85	3.40	86.37	423.42	3.40	88.76	423.85	3.40	89.84	423.85	3.40	86.37	423.42	3.40	88.76
26	86.37	560.00	45.00	88.76	560.00	45.00	88.76	560.00	45.00	86.37	560.00	45.00	88.76	560.00	45.00	88.76	560.00	45.00	86.37	560.00	45.00	88.76
27	12204.26	13.61	1.01	12688.33	17.93	1.01	13131.26	22.25	1.01	12104.89	10.50	1.01	12559.57	14.00	1.01	12971.09	17.50	1.01	12204.26	13.61	1.01	12688.33
28	11228.24	15.00	1.01	9919.40	20.00	1.01	10646.25	25.00	1.01	10646.25	15.00	1.01	10646.25	20.00	1.01	10646.25	25.00	1.01	11228.24	15.00	1.01	9919.40
29	2559.24	13.61	1.05	2653.39	17.93	1.05	2741.86	22.25	1.05	2559.24	13.61	1.05	2653.39	17.93	1.05	2741.86	22.25	1.05	2559.24	13.61	1.05	2653.39
30	190.60	10.50	1.01	201.53	14.00	1.01	211.10	17.50	1.01	190.60	10.50	1.01	201.53	14.00	1.01	211.10	17.50	1.01	190.60	10.50	1.01	201.53
31	122.04	13.61	1.01	126.88	17.93	1.01	131.31	22.25	1.01	122.04	13.61	1.01	126.88	17.93	1.01	131.31	22.25	1.01	122.04	13.61	1.01	126.88

Table A.4

Stream results for the natural gas plants with ambient temperatures 15, 20 and 25°C with wet-recirculating (columns marked green) and once-through (columns marked orange) cooling systems. The temperature rise in the condenser is 15K.

Stream	Mass [kg/s]	Temperature [°C]	Pressure [bar]	Mass [kg/s]	Temperature [°C]	Pressure
--------	-------------	------------------	----------------	-------------	------------------	----------

additional annual cost related to water use of 178.7 million Euro. Our baseline calculations of COWI, assume a water stress factor of 1 (low water stress level). A transition from a water stress level of a low-to-medium ranking (level 3) to the level of medium-to-high (level 4) would be equivalent to a 33% increase in the COWI. This would result in an increase in the COWI of 2.2 €/MWh for the coal plant with once-through system (COWI: 8.6€/MWh, for a cooling water temperature rise of 5 K) and an increase of 0.2 €/MWh for the natural gas plant with a recirculating system. The annual costs of the coal and natural gas plants would thus be increased by €6.6 million and €595.600, respectively. Today a large part of Europe is characterized by water stress levels of 4–6 (medium-to-high–extremely-high). This would result in COWI four to six times higher than the baseline results presented in this paper and would significantly increase the contribution of the COWI to the annual costs of the plants.

The minimum temperature difference in the condenser (studied only for plants with once-through cooling water systems) and the plant efficiency have a secondary impact on the calculation of the COWI, mainly because of the smaller range of plausible variability of these parameters. A 50% increase in the minimum temperature difference from the default value (blue line in Fig. 2) leads to a higher COWI, which would, for example, mean a total additional annual cost of €113,164 in the case of the natural gas plant (for a cooling water temperature rise of 7 K). A 20% decrease in the efficiency of the plant, would be linked to a total additional annual cost of €1.8 million in the case of the natural gas plant (for a cooling water temperature rise of 7 K). These costs would be three times higher for the analogous coal plant.

Lastly, it is also found that the cooling water inlet temperature does not influence the COWI strongly. It should be noted, however, that if the shifted points of operation accounted for the variation of all ambient streams (including the air temperature), the effect on the operation of the power plants would be much stronger. Nevertheless, it is intentionally chosen to isolate the effect of the water temperature on the operation of the plant and it should not be compared or confused with the influence of inlet water temperature in climate change scenarios.

The general equations defined in this paper allow, first, the straightforward and objective calculation of water cost in different plants and, second, the evaluation of the impact different parameters have on the calculated costs. A linear relationship between the COWI and the water temperature rise in the condenser exists because a linear relationship between the power output of the steam cycle and the circulating water flowing through the condenser has been assumed. The simulations are realized in the design mode of the software, without accounting for the non-linear part-load operation of the components. This was realized to make the individual simulations independent from a parent profile and to allow the design of each scenario for the corresponding specific starting conditions. The robustness of the proposed method is supported by the small errors compared to detailed simulations.

Nomenclature

Abbreviations

COE	cost of electricity
COWI	cost of water impacts
CT	cooling tower
CW	cooling water
EQQO	
ST	steam turbine
UAE	United Arab Emirates
WTA	withdrawal to available flow

Symbols

A, B, C	constants
f	factor
c	specific heat capacity ()
\dot{m}	mass flow rate (refers to the reference point of operation)
\dot{m}'	mass flow rate (refers to the shifted point of operation)
η	efficiency
\dot{Q}	thermal energy
T	temperature
\dot{W}	net power output (refers to the reference point of operation)
\dot{W}'	net power output at shifted points of operation, i.e., with increased inlet cooling water temperature
\dot{W}''	calculated net power output with reduced water availability (based on the shifted points of operation)
ΔT	temperature difference
$\Delta \dot{W}$	change in power output

Superscripts/subscripts

cons	consumption
in	refers to the reference point of operation
net	net (power output)
L	loss
min	minimum
mu	make-up (water)
F	fuel of the plant
PP	power plant
qual	quality
quant	quantity
tot	total
w	water
ws	water scarcity

CRedit authorship contribution statement

Fontina Petrakopoulou: Conceptualization, Analysis, Investigation, Methodology, Validation, Writing of the work.

Declaration of competing interest

The authors declare that they have no known competing financial interests or personal relationships that could have appeared to influence the work reported in this paper.

Acknowledgment

Fontina Petrakopoulou would like to thank the Spanish Ministry of Science, Innovation and Universities and the Universidad Carlos III de Madrid (Ramón y Cajal Programme, RYC-2016-20971).

Appendix

This appendix presents the flow diagrams of the power plants studied as simulated in the software EpsilonProfessional and the stream results of the simulations for the minimum and maximum temperature rise in the condenser: 3 and 15 K.

See Figs. A.1 and A.2 and Tables A.1–A.4.

References

- Averyt, K., Fisher, J., Huber-Lee, A., Lewis, A., Macknick, J., Madden, N., Rogers, J., Tellinghuisen, S., 2011. Freshwater use by U.S. power plants: Electricity's thirst for a precious resource - A Report of the Energy and Water in a Warming World Initiative.
- Baleta, J., Mikulčić, H., Klemeš, J.J., Urbaniec, K., Duić, N., 2019. Integration of energy, water and environmental systems for a sustainable development. *J. Clean. Prod.* 215, 1424–1436. <http://dx.doi.org/10.1016/j.jclepro.2019.01.035>.
- Behrens, P., van Vliet, M.T.H., Nanninga, T., Walsh, B., Rodrigues, J.F.D., 2017. Climate change and the vulnerability of electricity generation to water stress in the European union. *Nat. Energy* 2, 17114.
- Garrick, D.E., Hall, J.W., Dobson, A., Damania, R., Grafton, R.Q., Hope, R., Hepburn, C., Bark, R., Boltz, F., De Stefano, L., O'Donnell, E., Matthews, N., Money, A., 2017. Valuing water for sustainable development. *Science* 358, 1003–1005. <http://dx.doi.org/10.1126/science.aao4942>.
- Gassert, F., Reig, P., Luo, T., Maddocks, A., 2013. WRI - Aqueduct country and river basin rankings - A weighted aggregation of spatially distinct hydrological indicators.
- IEA, 2012. Water for energy - is energy becoming a thirstier resource?.
- IEA, 2016. Water-Energy Nexus. Technical report.
- Ifaei, P., Yoo, C., 2019. The compatibility of controlled power plants with self-sustainable models using a hybrid input/output and water-energy-carbon nexus analysis for climate change adaptation. *J. Clean. Prod.* 208, 753–777. <http://dx.doi.org/10.1016/j.jclepro.2018.10.150>.
- Kimmell, T.a., Veil, J.a., 2009. Impact of Drought on US Steam Electric Power Plant Cooling Water Intakes and Related Water Resource Management Issues, Technology.
- Liu, L., Hejazi, M., Li, H., Forman, B., Zhang, X., 2017. Vulnerability of US thermoelectric power generation to climate change when incorporating state-level environmental regulations. *Nat. Energy* 2, 17109. <http://dx.doi.org/10.1038/nenergy.2017.109>.
- Lubega, W.N., Stillwell, A.S., 2019. Analyzing the economic value of thermal power plant cooling water consumption. *Water Res. Econ.* 1–12. <http://dx.doi.org/10.1016/j.wre.2019.01.003>.
- Luo, T., Krishnaswami, A., Li, X., 2018. A methodology to estimate water demand for thermal power plants in data-scarce regions using satellite images.
- Medarac, H., Magagna, D., Hidalgo-González, I., 2018. Projected fresh water use from the European energy sector. In: EUR 29438 EN, Publications Office of the European Union, Luxembourg. ISBN: 978-92-79-97250-8, <http://dx.doi.org/10.2760/30414>. (online), JRC113696.
- Miara, A., Macknick, J.E., Vörösmarty, C.J., Tidwell, V.C., Newmark, R., Fekete, B., 2017. Climate and water resource change impacts and adaptation potential for US power supply. *Nat. Clim. Chang.* 7, 793–798.
- Miara, A., Vörösmarty, C.J., Macknick, J.E., Tidwell, V.C., Fekete, B., Corsi, F., Newmark, R., 2018. Thermal pollution impacts on rivers and power supply in the Mississippi River watershed. *Environ. Res. Lett.* 13, 034033. <http://dx.doi.org/10.1088/1748-9326/aaac85>.
- Morrill, J.C., Bales, R.C., Conklin, M.H., 2005. Estimating stream temperature from air temperature: Implications for future water quality. *J. Environ. Eng.* 131, 139–146. [http://dx.doi.org/10.1061/\(ASCE\)0733-9372\(2005\)131:1\(139\)](http://dx.doi.org/10.1061/(ASCE)0733-9372(2005)131:1(139)).
- Peer, R.A.M., Sanders, K.T., 2018. The water consequences of a transitioning US power sector. *Appl. Energy* 210, 613–622. <http://dx.doi.org/10.1016/j.apenergy.2017.08.021>.
- Petrakopoulou, F., Robinson, A., Olmeda-Delgado, M., 2020. Impact of climate change on fossil fuel power-plant efficiency and water use. *J. Clean. Prod.* 273, 122816.
- Rogers, J., Averyt, K., Clemmer, S., Davis, M., Flores-Lopez, F., Frumhoff, P., Kenney, D., Macknick, J., Madden, N., Meldrum, J., Overpeck, J., Sattler, S., Spanger-Siegrfried, E., Yates, D., 2013. Water-Smart Power: Strengthening the U.S. Electricity System in a Warming World. Cambridge, MA.
- Statista, 2018. Levelized cost of electricity worldwide by country 2020 [WWW Document]. URL <https://www.statista.com/statistics/478005/global-levelized-electricity-cost-prediction-by-country/> (accessed 12.11.18).
- SteagEnergyServices, 2020. EBSILONProfessional [WWW Document].
- United Nations, World Bank, 2017. High-level Panel on Water: Sustainable Development Knowledge Platform [WWW Document]. URL <https://sustainabledevelopment.un.org/HLPWater> (accessed 12.20.17).
- U.S. Department of Energy, 2014. The water-energy nexus: Challenges and opportunities.
- US EPA, 2018. Cleaner Power Plants [WWW Document]. URL <https://www.epa.gov/mats/cleaner-power-plants> (accessed 10.3.19).
- van Vliet, M.T.H., Yearsley, J.R., Ludwig, F., Vögele, S., Lettenmaier, D.P., Kabat, P., 2012. Vulnerability of US and European electricity supply to climate change. *Nat. Clim. Chang.* 2, 676–681. <http://dx.doi.org/10.1038/nclimate1546>.
- World Energy Council, 2010. Water for Energy. London, UK.
- World Energy Council, 2016. World Energy Perspectives 2016 - The road to resilience - Managing the risks of the energy-water-food nexus.
- Wu, X.D., Ji, X., Li, C., Xia, X.H., Chen, G.Q., 2019. Water footprint of thermal power in China: Implications from the high amount of industrial water use by plant infrastructure of coal-fired generation system. *Energy Policy* 132, 452–461. <http://dx.doi.org/10.1016/j.enpol.2019.05.049>.
- Zhang, C., Zhong, L., Wang, J., 2018. Decoupling between water use and thermoelectric power generation growth in China. *Nat. Energy* 3, 792–799.