



# How Space Robotics benefits from the World Standard for Motion Communication

White Paper, version: 03/07/2022

## Authors:

Imran Aslam<sup>‡</sup>, Alexander Beyer<sup>θ</sup>, Dr. Gerhard Grunwald<sup>θ</sup>, Dave Hiemstra<sup>‡</sup>, Greg Jimmerson<sup>◇</sup>, Valeri Kirischian<sup>‡</sup>, Martin Rostan<sup>†</sup>, Thomas Rettig<sup>‡</sup>, Manfred Schedl<sup>θ</sup>, Steffen Schwarz<sup>‡</sup>, Raphael R. Some<sup>ψ</sup>, Chris Thayer<sup>¶</sup>

‡ **Beckhoff Automation**

θ **DLR German Aerospace Center**

† **EtherCAT Technology Group**

¶ **Jena-Optronik**

‡ **mda MacDonald, Dettwiler and Associates**

¶ **Motiv Space Systems**

ψ **NASA Jet Propulsion Laboratory**

◇ **Tethers Unlimited**

## Abstract:

Space-specific communication technologies only partially meet the technical needs of space robotics and have disadvantages in terms of the strategic demands for openness, vendor diversity, and cost. EtherCAT is the Ethernet-based world standard for motion communication also widely used for robotics. In this paper, we describe how EtherCAT meets the specific requirements of space robotics. Moreover, we show how the space industry benefits from agreeing on this technology for robotics.

## Published by:

EtherCAT Technology Group

Ostendstr. 196, 90482 Nuremberg, Germany

Phone: +49 911 540 56 20, fax: +49 911 540 56 29, email: [info@ethercat.org](mailto:info@ethercat.org), web: [www.ethercat.org](http://www.ethercat.org)

# How Space Robotics benefits from the World Standard for Motion Communication

Martin Rostan  
*EtherCAT Technology Group*  
Nuremberg, Germany  
m.rostan@ethercat.org

Dr. Gerhard Grunwald  
*Institute of Robotics and  
Mechatronics*  
DLR German Aerospace Center  
Weßling, Germany  
gerhard.grunwald@dlr.de

Valeri Kirischian  
*mda MacDonald, Dettwiler and  
Associates*  
Brampton, ON, Canada  
valeri.kirischian@mda.space

Steffen Schwarz  
*Jena-Optronik*  
Jena, Germany  
steffen.schwarz@jena-  
optronik.de

Imran Aslam  
*mda MacDonald, Dettwiler and  
Associates*  
Brampton, ON, Canada  
imran.alsam@mda.space

Dave Hiemstra  
*mda MacDonald, Dettwiler and  
Associates*  
Brampton, ON, Canada  
dave.hiemstra@mda.space

Thomas Rettig  
*Beckhoff Automation  
Verl, Germany*  
t.rettig@beckhoff.com

Raphael R. Some  
*California Institute of Technology  
Jet Propulsion Laboratory*  
Pasadena, CA, USA  
raphael.r.some@jpl.nasa.com

Alexander Beyer  
*Institute of Robotics and  
Mechatronics*  
DLR German Aerospace Center  
Weßling, Germany  
alexander.beyer@dlr.de

Greg Jimmerson  
*Tethers Unlimited,  
Bothell, WA, USA*  
jimmerson@tethers.com

Manfred Schedl  
*Institute of Robotics and  
Mechatronics*  
DLR German Aerospace Center  
Weßling, Germany  
manfred.schedl@dlr.de

Chris Thayer  
*motiv space systems*  
Pasadena, CA, USA  
chris.thayer@motivss.com

**Scope— The space industry is in transition and has realized that sticking to proprietary technologies is a cost trap, while adopting proven standards leads to success faster and more economically. This is particularly true for space robotics and its communication technologies: agreeing on a uniform standard makes particular sense here, because this leads to standard components from which all space robot makers benefit. This paper discusses the fieldbus requirements of space robotics and shows how EtherCAT - the world standard for motion communication - meets these requirements.**

## I. INTRODUCTION

Service robotic systems are differing from their industrial robot ancestors by extensive use of internal and external sensor data, having a kinematics with 7dof and more, and interacting in close vicinity to other technical systems or even in co-operation with humans. From the technical perspective, this requires a high-performance control and communication. In addition, feedback control of soft robotics needs advanced real-time capabilities and strong determinism in communication. For systems with higher softness and improved reactivity sampling rates in excess of 1kHz are required. Nowadays these robot systems are creating new markets for robot and servicing systems.

Simultaneously, the space flight is asking more and more for dexterous robots and the application field is as manifold as on earth. Rovers equipped with robot arms for (semi-)autonomous exploration of foreign planets will be the extended arm of scientists, therefore the performance must be comparable to

human arms. Mid-term on-orbit missions and concepts are relying on the use of many robot arms of different sizes, dexterity, and performances. Orbital services, repair, and maintenance are the buzzwords of today. Assembly in space is the newest challenge.

From the functional perspective there is no real difference between robot services on earth or in space. It is thus a reasonable approach relying on the robotics and automation experiences on earth. The technology is proven, worldwide applied, standardized, low cost with respect to the tasks, and sufficient human resources are available. The spin-in of automation technology will offer new opportunities at lower costs for the space business.

The autonomous assembly of large structures in space is a key challenge for future missions that will necessitate structures too large to transport in a single piece. The James Webb Space Telescope has reached this limit and the next generation telescope expected by astronomers, like the High Definition Space Telescope, will therefore require new assembly technologies, in particular autonomous robots. The need for large structures in space goes beyond telescopes and concerns also solar arrays for power plants, light sails to reach outermost regions of the solar system or heat shields to land on Mars.

The current state is, that there are a variety of space-specific communication technologies, but most of them only partially meet the increasing communication performance requirements (speed, latency, determinism) of impedance-controlled space robots, which is further increased by the transition from single-axis view to complex, centrally controlled kinematics. For the

software implementation, standard drive profiles are not available, so that every implementation reinvents the wheel.

Besides the technical limitations, most existing communication technologies for space applications have strategic disadvantages for the usage in space robotics, such as the dependency on one manufacturer and or only slow further development, and lack of availability of standard components.

Therefore, more and more players in this growing market understand that the communication technology is no suitable differentiation feature but rely on technologies from general robotics to simplify and speed up the space robotics development and testability. Of course, these data bus technologies also must support the overall system avionics architecture in meeting the mass, power, volume, reliability, and flexibility demands imposed by the mission requirements.

## II. REQUIREMENTS TO A COMMUNICATION STANDARD FOR SPACE ROBOTIC

### A. TECHNICAL

#### 1) *Performance*

The core functionality for space robotic applications is motion control, and the performance requirements of space robotic applications are meanwhile like those of robots on earth. Although the movement velocities in space are usually lower, the extreme lightweight construction means that the systems are less rigid and therefore must be controlled highly dynamically and with low overall system delay margin. This requires cycle times down to significantly below one millisecond and precise synchronization accuracy for equidistance of position scanning and synchronization of multi-degree-of-freedom (DOF) systems, since space robots are no longer seen as individual axes lined up in a row, but as a complete system moved dynamically and synchronously.

#### 2) *Topology*

Space robotics applications require a network structure that can adapt to dynamic configuration changes such as the addition of payload tools, sensors, cameras etc. to a robotics system. The data bus must accommodate a changing network topology by automatically detecting, addressing, and communicating with added nodes with minimal network initialization delays and hardware configuration changes.

#### 3) *High Availability*

By its very nature, high availability is of much greater importance in space. System reliability requires different levels of redundancy depending on the mission: from cable redundancy via controller redundancy to independent primary and secondary networks. A space robotics communication technology must support these features. Ideally a technology supports cross-strapping between prime and redundant network nodes with minimal cabling and switches so that the robotics can operate with any combination of prime and redundant channel nodes, improve system reliability, and reduce the impact of individual node failures.

#### 4) *Environment*

A communication system for space robotics must be able to meet the extended requirements for radiation robustness, temperature, shock, vibration and so on. These are derived from

the character of the mission and therefore cannot be quantified in general terms.

#### 5) *Integrated solutions*

Development, qualification, debugging, cost, and time can be saved by communication technologies that provide the node implementation with an FPGA IP core. An FPGA based implementation provides the following advantages:

- **Radiation Tolerant Hardware Availability:** Technologies that provide IP cores for the radiation tolerant path to flight FPGAs significantly reduce development time and cost associated with qualifying an ASIC for the flight radiation environment.
- **Low Utilization:** The lower the FPGA utilization for the IP Core, the more headroom available for the application specific controller logic.
- **Small Circuit Card Footprint:** By combining the node controller with application specific firmware in the same FPGA, developers can optimize the electronics circuit card assembly (CCA) form factors that support the volume constraints of the assembly.

#### 6) *Testability and Verification*

Space systems and their interfaces must be tested very carefully because implementation errors cannot be corrected during operation or can only be corrected with great difficulty. Accordingly, the testing effort usually exceeds the actual implementation effort, also for the communications interfaces. This can be reduced considerably if the bus technology provides extensive and proven conformance test systems.

#### 7) *Flexibility of test set-ups*

Space technologies need to be replicated on a high-fidelity ground-based test bed that will be used to exercise, verify, test, and debug the system during development or flight. Additional sensors should be easy to integrate time-synchronously within the overall system. A technology that has supporting test equipment, less expensive, and commercially available off the shelf hardware/software for implementation of the communication bus architecture in a ground-based test bed is preferred over one that will require the time and expense of more specialty or custom GSE development.

#### 8) *Interfacing to other communication systems or data sources*

It is often necessary to integrate subsystems using other bus technologies – such as grippers or equipment for test set-ups – into the robot control system. It must also be possible to integrate the robot itself into other environments. Therefore, the availability of interfaces to other bus systems is an indispensable requirement. Beneficial would be the capability to transfer data from additional sensors or cameras that are not part of the robot system itself without jeopardizing the real-time properties: this would avoid additional cabling.

#### 9) *Cables with low rigidity and torsional stiffness*

Space robots operate in gravity-free conditions and thus with low forces, and therefore interference caused by inflexible cables should be largely avoided. Therefore, the availability of

communication cables with low rigidity and torsional stiffness is of importance.

10) *Safety*

Communication-integrated functional safety according to IEC 61508 is only slowly finding its way into space robotics. Up to now, humans have rarely been in the workspace of the moving robot in space, and so simple shutdown is usually sufficient for personal protection, also thanks to relatively slow movements combined with the low forces generated by robots in space. However, it is foreseeable that this will change. Therefore, a communication system for space robotics should fundamentally support integrated functional safety.

11) *Security*

Cyber security is gaining importance everywhere, so it would be reassuring if the space robotics bus system has no weaknesses in this regard.

B. *Strategic*

The strategic requirements for a communications standard for space robotics are less detailed than the technical ones, but equally important:

1) *Openness*

Open access to technology avoids dependency on individual suppliers and is therefore a central strategic requirement for a space robotics bus system. Ideally, openness extends beyond the space industry to increase supplier diversity and ensure the momentum of ongoing technological progress. Thus the technology should be an international standard.

2) *Large Community*

Only when the bus technology is backed by a large community broad support for space robotics component and

system providers is available. Moreover, a large supporting community leads to long term availability.

3) *Stable*

Technical progress, improvements and functional enhancements are important and necessary, but should preferably not be accompanied by new incompatible versions of the technology. Communication systems in particular are known for sacrificing stability for improvements and generating versioning problems. However, this is particularly problematic for space applications because development cycles are relatively long.

4) *Cost effective*

Costs are also playing an increasingly important role in space applications, and it goes without saying that the robotic bus system must contribute to cost savings.

5) *Proven in robotics*

A technology for space robots should already have proven itself in other robot applications. This is a matter of common sense but is not always taken into account.

6) *Roadmap*

Even if a bus technology already must meet all technical and strategic requirements today, the existence of a technology roadmap would be helpful because it suggests that future requirements can also be covered with the same solution.

III. THE UNIQUE ETHERCAT FUNCTIONAL PRINCIPLE

1) *The Ethernet real-time challenge*

Ethernet provides a robust and space proven physical layer and a data link layer with good error detection mechanisms that can host a virtually unlimited protocol variety. However, IT-

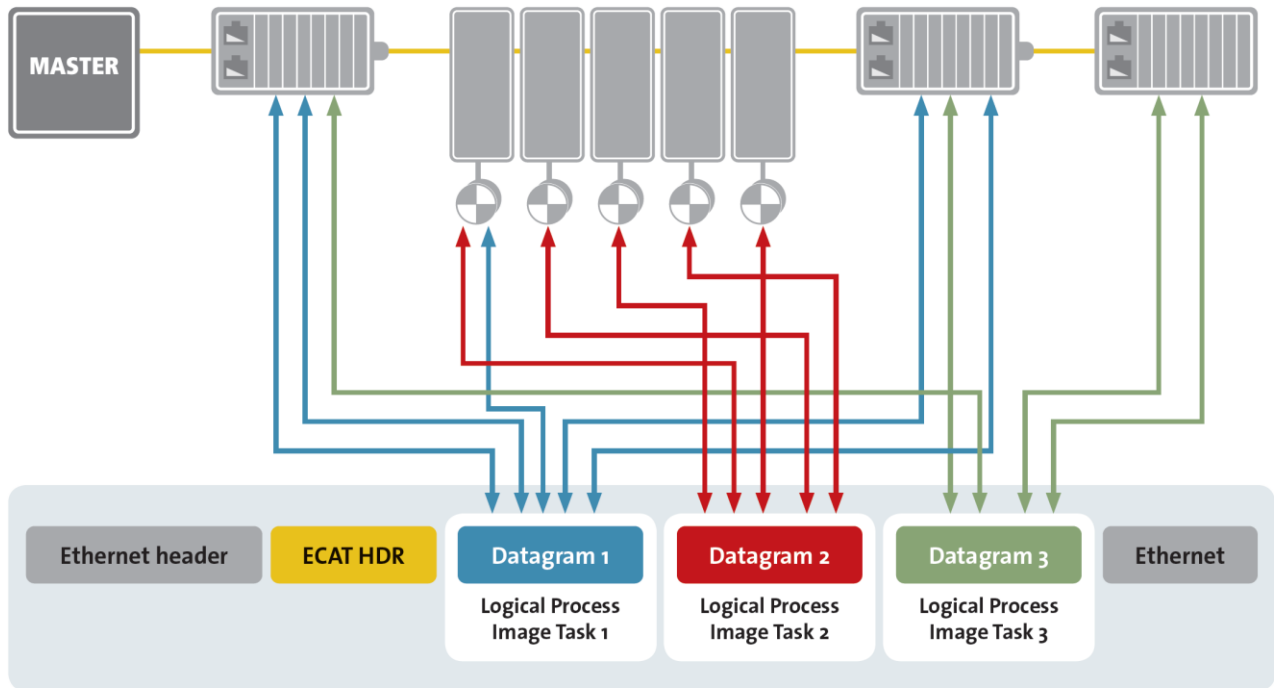

Fig. 1: Functional Principle: EtherCAT devices insert data and extract data on the fly within the same Ethernet frame

style Ethernet lacks determinism and has poor bandwidth utilization for small process data units such as those needed to control drives. In addition, large protocol software stacks in the network nodes not only increase complexity and thus error-proneness and local processing delays, but also require computing power and memory, which is especially undesirable for space applications.

The determinism issue can be addressed by extensions of switches combined with complex traffic planning, and the bandwidth issue by higher bit rates, but these have disadvantages in terms of robustness.

2) *EtherCAT approach: Processing on the fly*

EtherCAT takes a different approach with its unique functional principle of "processing on the fly". Instead of sending a separate Ethernet frame to each connected device and receiving a response frame from each device in every communication cycle, the EtherCAT controller sends one single frame containing all process data through all devices, and each device extracts its output data from this frame and inserts its input data into the same frame (Fig. 1).

Distributed clocks in the devices are synchronized with the very same frame in such a way that the sending determinism of the frame has no influence on the synchronization accuracy: the frame contains the clock time of the first device which is latched by the subsequent devices and used for adjusting the local clock.

The EtherCAT functional principle results in maximum performance through the best possible use of bandwidth and at the same time leads to highly accurate synchronization of the connected devices (Fig. 2)

But not only that: it lowers the complexity of Ethernet below the level of classic fieldbuses without limiting the Ethernet capabilities, since EtherCAT can also transmit any IT-protocols such as TCP/IP in addition, if required, without diluting the real-time properties. EtherCAT does not require large software stacks because the key functionality is implemented in the

EtherCAT chips in hardware. For the network master no special chips are needed: here an Ethernet MAC with a lean software is sufficient as the master typically only sends one standard Ethernet frame per cycle and receives one.

Neither switches nor their configuration are required, which also means that EtherCAT supports the line topology without the limitations imposed by cascaded switches.

IV. ETHERCAT MEETS THE TECHNICAL REQUIREMENTS

1) *Performance*

EtherCAT is known to be the fastest industrial Ethernet Technology, since it makes optimum use of the available bandwidth due to its functional principle. Typical cycle times start at 50µs, and 100 drives can be updated every 100 µs. The Distributed Clocks synchronization mechanism results in a jitter of less than 100ns, which is also achieved in networks without a precision clock in the master: the nodes share the clock time already present in the chips. The system scales very well, so that additional nodes have minimal effect on the latency, which is appreciated by every control software architect.

2) *Topology*

EtherCAT supports any topology without affecting performance and without the complexity that arises from cascading switches or hubs: line, tree, star topologies can be freely combined. There can be up to 65,535 nodes per segment. A master can host several segments. EtherCAT masters can automatically detect network changes using a topology recognition feature which compares the actual network to the configuration expected by the master and can reconfigure accordingly. Hence, nodes can be connected and disconnected during operation. The dynamically adapting network recognition permits network segments or individual nodes to be connected and disconnected during operation such as when a robotic manipulator grapples onto and connects to specific EtherCAT based sensor tools. EtherCAT slave controllers include the basis for this Hot Connect feature. EtherCAT automatically assigns addresses to slave nodes, and hence no manual addressing is required. This is highly supportive of the changing robotic manipulator configurations where the robotics has to extend its internal data network to include external grappled loads and/or sensors. Addresses can be kept so that no new addressing is required if more nodes are added because at boot-up the addresses are assigned automatically.

3) *High Availability*

EtherCAT achieves cable redundancy by the ring topology without the network nodes or their chips having to have special properties. If a neighboring node (or tool) is removed from the network, the port is automatically closed so the rest of the network can continue to operate. Very short detection times < 15 µs guarantee a smooth transition. This also prevents the limitation that a failure in one node can disable the whole segment. Master redundancy with hot standby is also possible. EtherCAT can detect topology changes due to failures, disconnection, or addition of slaves with a node discovery method by querying the nodes through the network whereas the nodes not only respond with their identification, but also with information regarding the connection status of each port. Hence, this ability to automatically reconfigure to accommodate

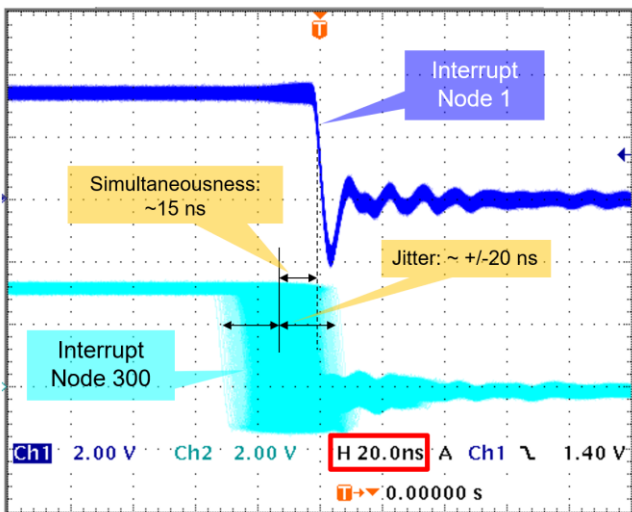

Fig. 2: EtherCAT synchronicity and simultaneousness: Long-term scope view of two distributed devices with 300 nodes an 120m of cable in between

changing nodes in the network supports the operational demands of space robotic applications. Furthermore, the network nodes can be equipped with several EtherCAT chips to achieve multiple redundancy - the combination of all these possibilities is used e.g. by NASA [1].

#### 4) *Environment*

Chips with EtherCAT slave controller functionality are already available from 12 semiconductor manufacturers: including those for extended environmental requirements such as temperature, shock or impermeability. A Beckhoff EtherCAT ASIC type was put through extensive irradiation tests in preparation for ISS missions (LEO) and was found to be suitable for space use. In addition, there are three different FPGA manufacturers for whose devices an EtherCAT IP core is available: Xilinx, Intel and Microchip - also for the respective radiation-tolerant and radiation-hardened space grade devices. Thus, EtherCAT semiconductors are available for the full range of space mission requirements.

#### 5) *Integrated solutions*

The chip variety of EtherCAT also includes highly integrated devices: with a wide variety of peripherals, CPU/ $\mu$ C cores and memory. The flexibility is naturally even greater with the FPGA solutions: here the exact functional scope of both the EtherCAT IP core and the other features can be adapted exactly to the requirements, thus reducing the number of components on the circuit board and its size and weight.

#### 6) *Testability and Verification*

Well-functioning interoperability is the prerequisite for the success of an open communication technology. That is why the EtherCAT Technology Group has placed emphasis on testing and certification from the very beginning. The comprehensive EtherCAT Conformance Test Tool (CTT) tests devices with well over 1000 test cases for compliance with the standard, and accredited EtherCAT test centers in North America, Europe and Asia issue official test reports, on the basis of which the ETG issues certificates of conformance. The CTT can also be extended by the developer with additional test cases, which can be used e.g. in a consortium to test specific functional extensions.

#### 7) *Flexibility of test set-ups*

Thanks to the openness of the technology and the great acceptance in the market even beyond space and aerospace applications, COTS devices are available for practically all requirements of e.g., test set-ups. For example, there are well over 1000 different I/O devices for virtually all signal variants and in many form factors, and a similar wide variety of drive components. EtherCAT controllers support all common programming languages, and tools such as Matlab Simulink. This allows prototypes and test setups to be implemented flexibly and quickly. Thus, EtherCAT comes fully equipped with plug and play test bed solutions that provide a wide suite of system diagnostic features and tools which can help detect and locate errors or track performance.

#### 8) *Interfacing to other communication systems or data sources*

The efficient bandwidth utilization of EtherCAT allows to tunnel other protocols over the network. These can be individual

telegrams/frames or entire process images of fieldbus systems. With "Ethernet over EtherCAT" (EoE) any Ethernet protocols are tunneled via EtherCAT without affecting its real-time properties. The mapping of fieldbus gateways to EtherCAT is also standardized within the ETG, so that the process data and parameters are transferred consistently, and the controller does not have to differentiate functionally between native EtherCAT devices and devices connected to underlying bus systems. There are now gateways to 35 different fieldbus systems.

#### 9) *Cables with low rigidity and torsional stiffness*

EtherCAT does not change the 100BASE-TX Ethernet physical layer. 100BASE-TX cabling provides a low conductor count, a small cable outer diameter and associated bend radius to minimize volume impact for a robotics assembly, and EtherCAT be operated with the entire variety of corresponding cables. This also includes very flexible and bendable cables as required for space robotics. Optical fibers according to 100BASE-FX are suitable for large expansions and special requirements. EtherCAT P also provides a solution for nodes that are to be supplied with data and power via a single line: 2 x 24VDC/3A and full-duplex EtherCAT communication are transmitted via 4 wires. For higher power there are hybrid cables with additional wires.

#### 10) *Safety*

An additional level of reliability is achieved with the protocol extension "Fail Safe over EtherCAT" [2] (FSoE also known as "Safety over EtherCAT"). The TÜV approved protocol has a proven residual error probability of < 10<sup>-9</sup>/h and meets the requirements of Safety Integrity Level (SIL) 3 with single channel communication, whereas SIL4 can also be achieved with additional measures. A well-developed ecosystem including a TÜV-certified test tool facilitates implementation, and Safety over EtherCAT also meets the more stringent requirements of the latest edition of IEC61784-3 without modification.

#### 11) *Security*

EtherCAT is inherently hardened against cyber-attacks: The protocol is not based on the Internet Protocol and thus eliminates almost all attacks from the outset. Non-EtherCAT frames are filtered out in hardware by the EtherCAT chips. Additional unwanted EtherCAT nodes cannot communicate unless actively enabled by the master, and topology modifications are also recognized by the master. Unused ports are switched off by the master so that unintentionally connected nodes cannot cause any damage. EtherCAT is therefore secure without the complexity of certificate handling.

## V. HOW ETHERCAT MEETS THE STRATEGIC REQUIREMENTS

### 1) *Openness*

EtherCAT is an open standard that can be implemented and used by anyone. As an IEC standard EtherCAT [3][4], the EtherCAT drive profile [5] and Safety over EtherCAT are internationally recognized. In countries where IEC standards are not automatically acknowledged (such as China and South Korea) EtherCAT is also a national standard [6][7]. The specification is available in English, Chinese, Korean and Japanese.

## 2) *Large Community*

EtherCAT is supported and maintained by the EtherCAT Technology Group (ETG). With over 6500 member companies from 69 countries [8], ETG is the world's largest fieldbus organization. Several hundred of ETG's members are active in the space and aerospace sector.

## 3) *Stable*

ETG has succeeded in advancing EtherCAT without versioning issues known from other communication technologies: with EtherCAT new features have been added without changing the existing ones. Older devices can be easily replaced by newer ones without having to consider network protocol versions. This provides a stability of the technology that is second to none and ensures long-term availability and investment security.

## 4) *Cost effective*

The costs are primarily determined by two factors: Vendor variety and implementation complexity. A large variety of vendors ensures low prices and fully featured products. EtherCAT has the widest vendor and product variety of all Industrial Ethernet solutions: over 3000 vendors have registered as official EtherCAT suppliers, offering the full range of products for any type of application. Simple implementation is particularly important in space programs, as it reduces the probability of errors. With EtherCAT, the complex part of the implementation is embedded in the chips and not in the stacks. The chips (including the IP cores) are deployed in many millions of nodes and are very mature. The EtherCAT protocol stacks are extremely lean – also on the controller(master) side and have successfully implemented I thousands of products. The availability of tools from different manufacturers additionally contributes to easy implementation and thus to cost reduction.

## 5) *Proven in robotics*

EtherCAT is the leading industrial Ethernet motion bus system used by many robot makers as system bus. Industrial, medical, and humanoid robots can meanwhile be divided into three categories regarding the communication systems used: its either EtherCAT, or they still use CAN, or self-developed technologies from the time when EtherCAT was not yet available. All other bus systems no longer matter.

A prominent example is Kuka, the market leading robot supplier to the automotive industry: All Kuka robots have been EtherCAT robots since 2010.

## 6) *Roadmap*

EtherCAT is proven and mature a million times over, but it is far from the end of its possibilities: ETG is working on the next fully backward compatible extension: with bit rates of 1 Gbit/s and more, EtherCAT G provides even more bandwidth. A focus of this development is the seamless integration of 100 Mbit/s EtherCAT networks, so that current devices and developments will not become obsolete or redundant through EtherCAT G.

EtherCAT G ensures that in 25 years EtherCAT will still be the technology of choice for fast, deterministic communication in control applications.

## VI. PROVEN IN SPACE APPLICATIONS

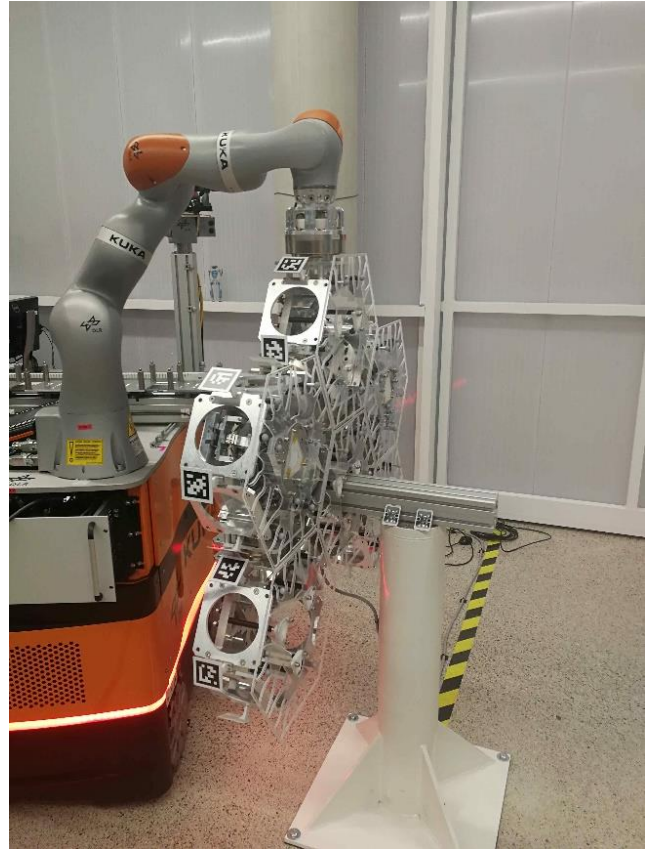

Fig. 3: PULSAR: KUKA KMR iiwa Mobile Manipulator

### 1) *EtherCAT on ISS*

EtherCAT has been used in space applications since 2015. It is permitted to report about the project "Kontur 2"[9], a joint project of the German Aerospace Center DLR and the Russian Federal Space Agency ROSCOSMOS, as well as about the „Haptics-2” flight experiment within the METERON project [10] of the European Space Agency (ESA) in conjunction with NASA. In both projects an EtherCAT equipped joystick was deployed to ISS, and EtherCAT was selected for its determinism, its openness and the radiation robustness of the ET1100 EtherCAT Slave Controller chip, which was tested extensively with different radiation sources and doses [11].

### 2) *PULSAR*

The multi-national team of the EC-funded project PULSAR [12] has developed a robot system for demonstrating the on-orbit assembly of a space telescope. One demonstrator of Pulsar was set-up by the DLR Robotics and Mechatronics Institute. The EtherCAT based robotics demonstrator is a KUKA KMR iiwa Mobile Manipulator with some additional sensor systems.

Such assembly tasks as demonstrated in PULSAR (Fig. 3) need an impedance-controlled robot arm, like the iiwa robot arm.

### 3) CAESAR

Currently the DLR Institute of Robotics and Mechatronics is setting up the CAESAR [13] arm, based on the same technology as iiwa. The 7dof robot arm (Fig. 4) is equipped with torque sensors in each joint, intelligent joint control units and EtherCAT as the fast, deterministic communication system.



Fig. 4: CAESAR (Compliant Assistance and Exploration SpAce Robot)

CAESAR is a robotic system designed for commercial use in space business. It brings the benefits of terrestrial light weight robots and the philosophy used in the design of Cobots into orbit. Based on joint torque sensing capabilities, complex joint state-control and cartesian impedance control at the tool center point, it is able to cope with any kind of activity needed in On-Orbit-Servicing. Pick and Place operations, Docking and Berthing, manipulation, up to maintenance and refueling are possible with the needed reliability and robustness. Small deviations in the scenario or in instantaneous changes in occurring contact forces are handled by the controller of the robotic arm.

To accomplish that the dynamic behavior of the robot's end effector can be adapted in stiffness and damping to match the requirements. Even in unexpected Off-Nominal situations like collisions with the robots structure a risk minimizing strategy to stop the maneuver is possible as the sensory information is available all over the arm in each of the joints.

To implement all of these features a reliable real-time exchange of measured and reference values, adaptable limits, control and performance parameters as well as housekeeping data has to be guaranteed. A mission specific base power

insulation unit adapts the robots necessary supply to the spacecraft.

By integrating an additional EtherCAT slave at the last joint and programmable logic various interfaces to end effectors, lighting units, tool changers and even camera systems can be realized without additional cabling inside the robotic arm.

## VII. SUMMARY

Space robotics applications require data bus technologies that not only support the real-time deterministic performance and data rate requirements of internal control loops, but also support the overall system avionics architecture in meeting the mass, power, volume, reliability, and flexibility demands imposed by the mission requirements.

Space applications such as robotic manipulators need to minimize the impact of the mass, stiffness, and diameters of the network harnesses, and make use of topologies that minimize the use of additional hardware and associated mass and power of repeaters, hubs, and switches. This must be accomplished while still affording the ability to support a dynamically configurable network topology for applications such as interfacing with robotic tools, sensors, cameras, or other payloads.

The lack of onsite repair options coupled with long mission durations require the use of network architectures that support fault tolerance and redundancy features for circumnavigating around failed nodes.

Implementation of the node controllers using qualified FPGAs allows space avionics developers to meet the goals of mission EEE parts reliability and radiation environments without the added cost and schedule burden of an ASIC screening, qualification, and radiation test campaign which is becoming increasingly more expensive for GEO missions.

Finally, all space applications require a ground-based test bed which emulates the hardware and software functions of the flight unit in order to support testing during development and debugging when the flight hardware is deployed. Technologies that come fully equipped with low cost, low schedule, plug and play test bed solutions and provide a wide suite of system diagnostic features are crucial for both the development and flight phases of the mission.

With all of these considerations in mind, EtherCAT proves to be an ideal choice for the next generation space avionics communication technologies for deterministic motion control and sensor interface applications.

## REFERENCES

- [1] T. Rettig, J. Stubbs: "NASA develops Modular Robot Vehicle", PC-Control magazine 02 2016,
- [2] IEC 61784-3-12: Industrial communication networks – Profiles, Part 3: Functional safety fieldbuses - Additional specifications for CPF 12 (EtherCAT™)
- [3] IEC 61158-3/4/5/6 Industrial communication networks – Fieldbus specifications Type 12 (EtherCAT™): Part 3-12: Data-link layer service definition, Part 4-12: Data-link layer protocol specification, Part 5-12: Application layer service specification, Part 6-12: Application layer protocol specification



- [4] IEC 61784-5-12: Industrial communication networks – Profiles, Part 5: Installation of fieldbuses - Installation profiles for CPF 12 (EtherCAT™)
- [5] IEC 61800-7: Adjustable speed electrical power drive systems
- [6] GB/T 31230: Industrial ethernet fieldbus EtherCAT
- [7] GB/T 36006: Safety-over-EtherCAT
- [8] EtherCAT Technology Group Website [www.ethercat.org](http://www.ethercat.org)
- [9] C. Riecke et al.: “KONTUR-2 MISSION: THE DLR FORCE FEEDBACK JOYSTICK FORSPACE TELEMANIPULATION FROM THE ISS”
- [10] ESA: “Multi-Purpose End-To-End Robotic Operation Network”
- [11] ETG press release: “EtherCAT in outer Space: Robustness is paramount”
- [12] PULSAR: “Prototype of an Ultra Large Structure Assembly Robot”
- [13] CAESAR: “Compliant Assistance and Exploration SpAce Robot”
- [14] G. Grunwald et al.: “CAESAR: Space Robotics technology for assembly, maintenance, and repair”, International Astronautical Federation Space Systems Symposium 2018.