



AALBORG UNIVERSITY
DENMARK

Aalborg Universitet

Power and Energy Applications Based on Quantum Computing

The Possible Potentials of Grover's Algorithm

Habibi, Mohammad Reza; Golestan, Saeed; Soltanmanesh, Ali; Guerrero, Josep M.; Vasquez, Juan C.

Published in:
Electronics (Switzerland)

DOI (link to publication from Publisher):
[10.3390/electronics11182919](https://doi.org/10.3390/electronics11182919)

Creative Commons License
CC BY 4.0

Publication date:
2022

Document Version
Publisher's PDF, also known as Version of record

[Link to publication from Aalborg University](#)

Citation for published version (APA):

Habibi, M. R., Golestan, S., Soltanmanesh, A., Guerrero, J. M., & Vasquez, J. C. (2022). Power and Energy Applications Based on Quantum Computing: The Possible Potentials of Grover's Algorithm. *Electronics (Switzerland)*, 11(18), [2919]. <https://doi.org/10.3390/electronics11182919>

General rights

Copyright and moral rights for the publications made accessible in the public portal are retained by the authors and/or other copyright owners and it is a condition of accessing publications that users recognise and abide by the legal requirements associated with these rights.



- Users may download and print one copy of any publication from the public portal for the purpose of private study or research.
- You may not further distribute the material or use it for any profit-making activity or commercial gain
- You may freely distribute the URL identifying the publication in the public portal -

Take down policy

If you believe that this document breaches copyright please contact us at vbn@aub.aau.dk providing details, and we will remove access to the work immediately and investigate your claim.

Article

Power and Energy Applications Based on Quantum Computing: The Possible Potentials of Grover's Algorithm

Mohammad Reza Habibi ^{1,*}, Saeed Golestan ¹, Ali Soltanmanesh ², Josep M. Guerrero ¹
and Juan C. Vasquez ¹

¹ The Faculty of Engineering and Science, Aalborg University, 9220 Aalborg, Denmark

² Department of Chemistry, Sharif University of Technology, Tehran 1458889694, Iran

* Correspondence: mre@energy.aau.dk

Abstract: In quantum computing, calculations are achieved using quantum mechanics. Typically, two main phenomena of quantum mechanics (i.e., superposition and entanglement) allow quantum computing to solve some problems more efficiently than classical algorithms. The most well-known advantage of quantum computing is the speedup of some of the calculations, which have been performed before by classical applications. Scientists and engineers are attempting to use quantum computing in different fields of science, e.g., drug discovery, chemistry, computer science, etc. However, there are few attempts to use quantum computing in power and energy applications. This paper tries to highlight this gap by discussing one of the most famous quantum computing algorithms (i.e., Grover's algorithm) and discussing the potential applications of this algorithm in power and energy systems, which can serve as one of the starting points for using Grover's algorithm in power and energy systems.

Keywords: Grover's algorithm; power and energy applications; quantum bit; quantum computing; quantum mechanics



Citation: Habibi, M.R.; Golestan, S.; Soltanmanesh, A.; Guerrero, J.M.; Vasquez, J.C. Power and Energy Applications Based on Quantum Computing: The Possible Potentials of Grover's Algorithm. *Electronics* **2022**, *11*, 2919. <https://doi.org/10.3390/electronics11182919>

Academic Editor: Jingyang Fang

Received: 21 June 2022

Accepted: 7 September 2022

Published: 15 September 2022

Publisher's Note: MDPI stays neutral with regard to jurisdictional claims in published maps and institutional affiliations.



Copyright: © 2022 by the authors. Licensee MDPI, Basel, Switzerland. This article is an open access article distributed under the terms and conditions of the Creative Commons Attribution (CC BY) license (<https://creativecommons.org/licenses/by/4.0/>).

1. Introduction

Quantum computing (QC) can be understood as methods/algorithms that have been developed to solve computational problems based on quantum mechanics (QM). QM is a theory that was developed at the beginning of the 20th century to explain phenomena that the classical physics theories could not explain. The idea of QC and replacing classical computation with QC was initialized after the foundation of the QM. A strong connection between QM and computer science was made in 1980 by Paul Benioff, who made an important contribution by designing the quantum Turing machine [1].

Several quantum-based algorithms have been introduced and developed by scientists to solve some fundamental problems in computer science and mathematics. For example, Shor's algorithm [2] and Grover's algorithm [3] have been developed to solve important problems in computer science much faster than classical methods. Shor's algorithm is able to solve two problems based on the quantum algorithm, i.e., finding discrete logarithms and factoring integers [2]. In addition, Grover's algorithm can be deployed as a search algorithm to find an element with a specific property or constraint within an unstructured search space [3,4].

Previously, some works have been conducted related to QC in power and energy systems. For example, in [5], QC has been implemented for the transient analysis in power systems. In addition, in [6], QC has been deployed for power flow in power systems. Furthermore, [7] deployed quantum machine learning for the transient stability assessment of power grids. Furthermore, in [8], a quantum key distribution (QKD) method is discussed for the communication architecture of microgrids. In addition, in [9] introduced a QKD-based strategy for controlling microgrids. Further, in [10] proposed quantum network

microgrids, which can be programmable and can integrate QKD and software-defined networking. As another example, in [11] used QC for unit commitment. In addition, in [12] deployed the quantum-based strategy for the estimation in microgrids.

Quantum computation-based algorithms provide the opportunity to accelerate the rate of the calculations and reduce the complexity of some problems. However, for a real implementation of a quantum computation-based algorithm, more investigations and considerations about the hardware and quantum mechanics are required. Still, there are some challenges in quantum computing and information in connection with the physics of the system. For instance, due to the coherence in quantum, there is the possibility to store more information, but, in the case of losing the coherence, there is the risk of losing part of the stored information [13]. In addition, in quantum information-based research, the consideration of quantum correlation is vital [14]. In addition, the system can keep some quantum features even if the system is in a classical state [15].

The purpose of this paper is to discuss the importance of QC and especially Grover's algorithm in PE applications and show the possible directions and potentials of using QC in a PE application. It is important to note that, in QC, there are some algorithms that solve basic and important problems. Therefore, for the implementation of them in a special application such as a PE application, there is a need to convert and translate the problem of the PE application to a problem that may be solved by the quantum-based algorithm. In other words, an innovative, clever, and genius way is needed to convert the problems of a PE application to those that have been solved before by QC. In addition, it can be possible to develop new algorithms for the problems of the PE application. Furthermore, it can be possible to divide a problem in a PE application into smaller ones and try to solve the smaller sub-problems using QC. Therefore, many possible methods need to be evaluated for the implementation of QC in a PE application. Therefore, it definitely has its challenges, but due to the great potential of QC, the evaluation of different ways of using QC in the PE applications can provide valuable benefits.

This paper mainly focuses on the unstructured search problem and its quantum solution, i.e., Grover's search algorithm, which may provide a quadratic speedup compared to its classical counterparts in solving the search problem. The main objective of this paper is to highlight the great benefits of this algorithm in solving some problems in PE applications. The purpose of this paper is to discuss the potential of Grover's algorithm to be used for a PE application. This manuscript tries to discuss possible problems in a PE application, which can be converted or considered as a search-based problem, and talk about the potential of them to deploy quantum computing to accelerate the rate of calculations using Grover's algorithm. In addition, to have a greater understanding of Grover's algorithm, the basis of this algorithm is discussed in more detail.

The rest of this paper is organized as follows. Section 2 explains the basics of QC and its features. In Section 3, the basics of the unstructured search problem and Grover's search algorithms are presented. In Section 4, the potential of this algorithm in three aspects (i.e., reliability assessment, optimization, and control) of PE applications will be discussed. In addition, an example will be explained in Section 5. In addition, a discussion is provided in Section 6, and directions for future works and conclusions will be talked about in Section 7. Finally, an appendix is prepared in Appendix A.

2. Introduction to Quantum Bit

The difference between QC and classical computation lies in the way of creating and handling data. In classical computation, bits are the most basic information unit for the computation. Each bit can be 0 or 1. The concept of superposition should be introduced after quantum bit (qubit), as a linear combination of quantum states of 0 and 1 [4]

$$|\Psi\rangle = x_1|0\rangle + x_2|1\rangle \quad (1)$$

where x_1 and x_2 are complex coefficients. The coefficients should satisfy the following equality constraint [4]

$$|x_1|^2 + |x_2|^2 = 1, \quad (2)$$

where it means that if the state of the qubit is measured, it can be found in $|0\rangle$ or $|1\rangle$ with the probability of $|x_1|^2$ and $|x_2|^2$, respectively [4]. Figure 1 shows how the state of a qubit can be shown by the Bloch sphere, and the state of the qubit $|\Psi\rangle$ can be represented as follows [4]:

$$|\Psi\rangle = \cos\frac{\theta}{2}|0\rangle + e^{i\varphi}\sin\frac{\theta}{2}|1\rangle. \quad (3)$$

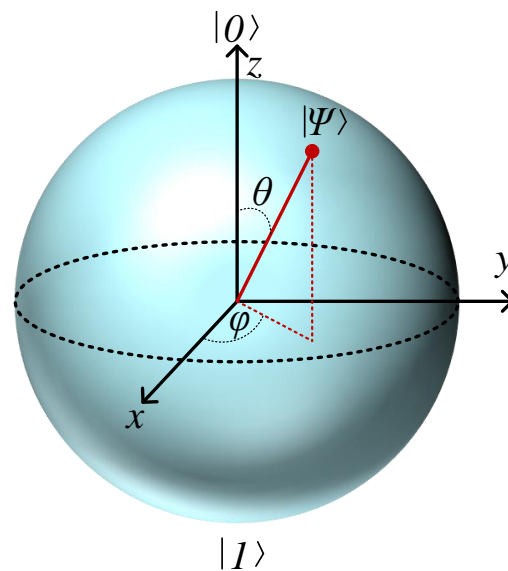

Figure 1. Visualization of the state of a qubit Ψ in the Bloch sphere (more details can be found in [4]).

3. Basics of the Unstructured Search Problem and Grover's Algorithm

In the unstructured search problem, the objective is to find the desired element with a specific property or constraint in a dataset, when there is no information about the search space. Note that in the case of a classical algorithm, $O(n)$ operators are needed to find the desired element in a search space with N elements. However, using Grover's algorithm, only $O(\sqrt{N})$ operators are needed. Therefore, it offers a quadratic speedup. Furthermore, it can be demonstrated that this algorithm is optimal, i.e., developing a faster algorithm is not possible [4]. These features highlight the importance and efficiency of Grover's algorithm.

In the rest of this part, the unstructured search problem will be introduced in more detail. Then, Grover's algorithm will be introduced and discussed. Further, the quantum circuit of this algorithm will be shown and explained. Finally, a conclusion about this part will be provided.

3.1. Unstructured Search Problem

As mentioned above, in an unstructured search problem, the problem is finding an element that should satisfy a constraint or should have a specific property. In addition, in this problem, there is no information about the structure of the search space. For example, assume that the search problem is finding an element with a specific situation among a set of elements. Having no information about the search space means that solving the search problem is only possible by checking elements. In the best case scenario, i.e., when the desired element is located in the first position, it can be recognized by the first check. However, in the worst-case scenario, i.e., when the desired element is located at the last position, after N times checking (N is the number of the elements in the search space), the desired element will be identified. Therefore, on average, one needs to check $\frac{N}{2}$ times to find the desired element. Therefore, a classical solution to the unstructured search problem

has $O(N)$ complexity. However, as mentioned before, Grover's algorithm can find the desired element by $O(\sqrt{N})$ operators or assessments. This fact is clarified later.

If the desired element is located at place i and if an algorithm starts from place i , it detects the desired element at the first checkpoint. However, if it starts from element $i + 1$, it needs to check all elements, i.e., the desired element will be detected at the last (N^{th}) checkpoint.

Mathematically speaking, if the search space includes N members, and if the desired datum is the i^{th} member, the search problem can be formulated as follows:

$$f : \{0, 1, 2, \dots, N - 2, N - 1\} \rightarrow \{0, 1\}, \quad (4)$$

where

$$f(x) = \begin{cases} 0 & \text{if } x \neq i \\ 1 & \text{for } x = i \end{cases} \quad (5)$$

In many cases, it can be very difficult to calculate or find the desired data or element directly, but it is possible to check a given datum, such as x or an element, to see if it is the answer or not. To better understand this, consider, for example, a ninth-order polynomial equation with an integer answer. The process of solving this equation can be difficult; however, it is still quite easy to check whether a given integer is the answer or not. Therefore, (5) is related to checking the specific constraint or the property of the j^{th} element. If $f(j) = 0$, it means that the j^{th} element is not the answer, but if $f(j) = 1$, it can be concluded that the j^{th} member is the answer and $j = i$.

Therefore, in some problems, it is very hard to find the solution and, at the same time, easy to check if an element is a response or not. In such cases, Grover's algorithm can be an efficient solution to solving the problem.

3.2. Introduction to Grover's Algorithm

As mentioned before, the main advantage of the QC could be the high speed of the calculations. For the case of Grover's algorithm, a quadratic speedup is achieved [4,16]. Note that search algorithms are needed in a wide variety of applications, which implies the quadratic speedup provided by Grover's algorithm can be a great help in solving such problems [4].

In Grover's algorithm, oracles play an important role. The task of an oracle is to determine whether a state or element is the answer or not. Note that the oracle will not solve the problem; it just checks a state to see if it is the response or not. In the algorithm, the oracle is represented by a quantum circuit. Therefore, a proper quantum circuit can be made based on (5), and it will be implemented in the quantum circuit of Grover's algorithm. Therefore, the oracle should be defined based on the search problem considering the property or the constraint of the desired element, which we are looking for. The oracle (U_O , which is a unitary matrix) behaves as follows [4]:

$$U_O|x\rangle = (-1)^{f(x)}|x\rangle \quad (6)$$

Figure 2 shows the relevant quantum circuit of Grover's algorithm. In Figure 2, first, the Hadamard transform is implemented to have an equal superposition as follows [4]:

$$|E\rangle = \frac{1}{\sqrt{N}} \sum_0^{N-1} |x\rangle. \quad (7)$$

Furthermore, Grover's operator is used in the quantum circuit of Figure 2. Grover's operator includes an oracle, two Hadamard transformers, and a conditional phase shift gate. In addition, Grover's operator is repeated $O(\sqrt{N})$ times in the circuit. Furthermore, if the combination of the two Hadamard transformers and the phase shift is called U_{Gr} , it operates as follows [4]:

$$U_{Gr} = (2|E\rangle\langle E| - I) \quad (8)$$

Furthermore, in [4]:

$$2|E\rangle\langle E| - I = H^{\otimes n}(2|0^n\rangle\langle 0^n| - I)H^{\otimes n}, \tag{9}$$

where, $\log_2^N = n$.

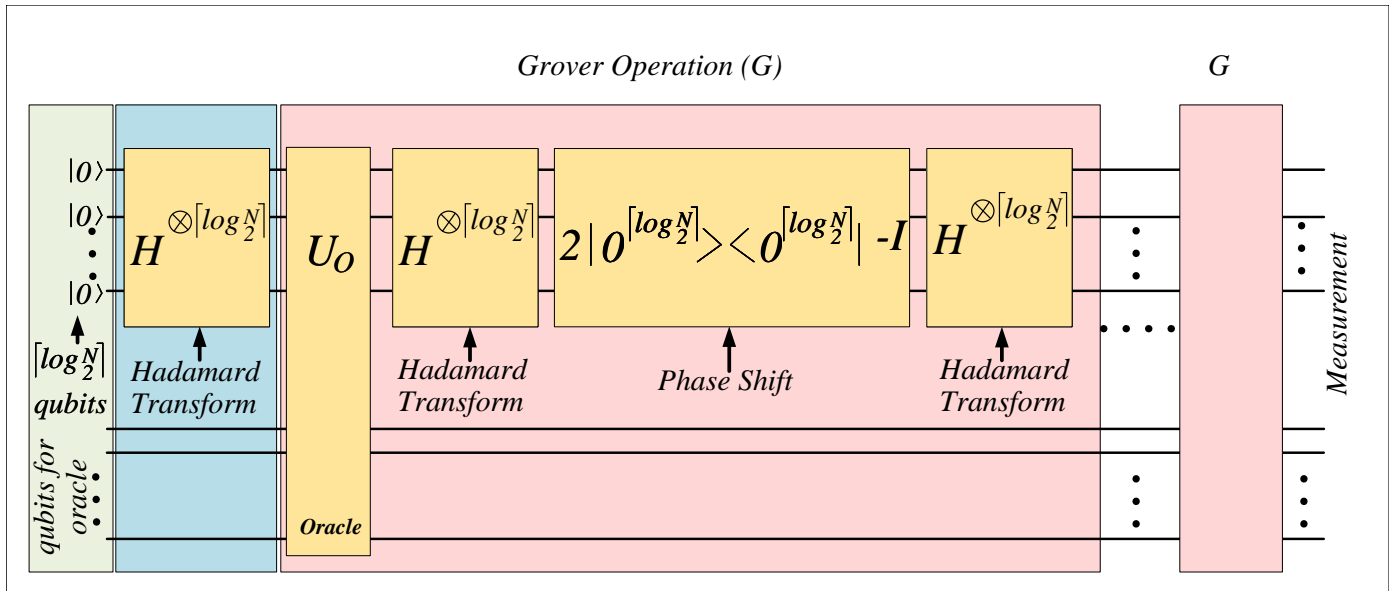

Figure 2. The quantum circuit of Grover’s algorithm (it is important to note that, if it is needed, some extra qubits can be used for the oracle), and detailed information can be found in [4].

For Grover’s algorithm, it is possible to have a geometrical visualization to show what can be happening based on the algorithm. For this visualization, for generalization, if there is K solutions among a search space with N possibility, the initial state can be written in the form of the solutions and the non-solution state as follows [4]:

$$|E\rangle = \sqrt{\frac{N - K}{N}}|E_{ns}\rangle + \sqrt{\frac{K}{N}}|E_s\rangle, \tag{10}$$

where E_s and E_{ns} are related to the solutions state and non-solutions state, respectively. The starting state can be shown in a 2D space [4], which is made by E_s and E_{ns} based on Figure 3. In Figure 3, α is as follows:

$$\alpha = \sin^{-1}\left(\sqrt{\frac{K}{N}}\right). \tag{11}$$

Based on Figure 3, Grover’s operator rotates the state for 2α radians closer to the solutions state. For a special case, if $K = 1$ and $1 \ll N$, it can be assumed that $\alpha = \sqrt{\frac{1}{N}}$. Therefore, the number of Grover’s operators (N_{Gr}) to find the solution can be approximately estimated as follows (more information can be found in [4]):

$$N_{Gr} = \frac{\frac{\pi}{2}}{2\sqrt{\frac{1}{N}}} = \frac{\pi}{4}\sqrt{N}. \tag{12}$$

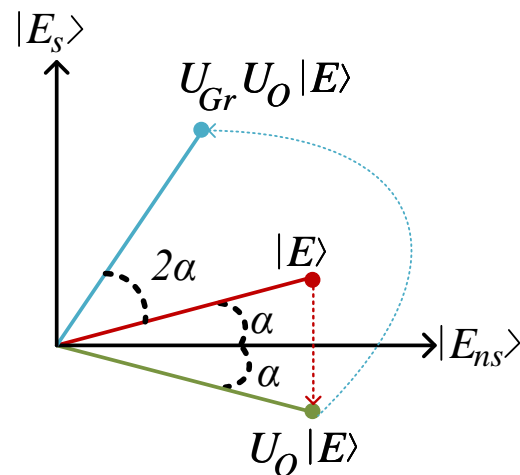

Figure 3. The starting state in a 2D space, which is made by E_s and E_{ns} and with the operation of Grover's operator, and more details can be found in [4].

Briefly, Grover's operator tries to make the state closer to the state of the solution to find the solution with a high probability. The circuit of Grover's algorithm firstly initializes a uniform superposition state, and after that, some Grover operators are implemented for the continuation of the circuit. In the rest of the paper, the possible potential of the QC and Grover's algorithm for solving the problems related to the PE applications will be discussed. After that, two basic examples will be explained to have a more in-depth realization about Grover's algorithm.

4. Potential of Grover's Algorithm in Power and Energy Applications

In this part, it will be discussed how QC algorithms, especially Grover's algorithm, can be employed in solving PE problems. As discussed before, the speed of the calculations by QC can be significantly greater than classical approaches. Therefore, if a system relies on a high volume of data gathering/processing, it can be highly recommended to use QC for the calculations. In PE applications (e.g., power systems, distribution systems, microgrids, and power electronic-based power systems), there are a lot of sensors to gather data and send them to local controllers or decision-making centers for different monitoring and control purposes. For example, in microgrids, a hierarchical control structure may be used. Therefore, different controllers are needed to be implemented in different control layers. As another example, in a power system, there can be a lot of controllable loads, and by gathering their data and using algorithms, a demand response application can be used to satisfy the loads and also consider the constraints and cost functions, e.g., technical constraints, and the operation cost of the system. In addition, the PE applications such as power systems and microgrids should work even under the outage of elements, e.g., transmission lines, generators, and buses. Therefore, a reliability assessment for them should be conducted to predict and see what may happen under different events or $N-k$ contingencies.

In addition, the classical algorithms and approaches to operate and control the PE application can have many constraints and sometimes more than one objective. Therefore, they can be very complex, and it can increase the run time of them to reach the desired response. Therefore, in very complex problems in the PE applications, some simplifications might be needed to make the problem easier to solve. Therefore, in these cases, the performance of the PE application may not be optimum. Furthermore, the PE applications are very important applications due to their important job of making a lot of systems alive. Therefore, the security of the PE applications is very vital. Some previous works have been conducted to increase the cybersecurity of the PE applications, e.g., microgrids. For example, in [17] investigated a method to detect cyber-attacks in a DC microgrid based on recurrent neural networks. Furthermore, in [18–21] introduced strategies to increase

the cybersecurity of DC microgrids by the implementation of artificial intelligence to mitigate cyber-attacks. It is important to note that, as discussed before, the QC provides an opportunity to solve problems ultrafast compared to classical methods. Therefore, if classical systems and methods are still used to operate and control PE applications, the vulnerability of the PE application to cyber-attacks by a quantum computer can increase.

Briefly, for PE applications, it could be necessary to gather a high volume of data and make calculations based on them in order to make decisions and control them in the right way to have a robust, secure, and trustable PE application. To increase the performance of the PE application, speed up their decision making, and reduce their vulnerability to cyber-attacks, it can be recommended to use QC in PE applications.

In the following, the potential of Grover's algorithm in a PE application will be discussed. Based on the best knowledge of the authors, the direct implementation of Grover's algorithm in a PE application could be a new direction with its own challenges and advantages. As mentioned before, the purpose of this paper is to discuss the possible applications in PE-based systems, which may be can be operated and improved by Grover's algorithm. Therefore, to continue, three applications in PE-based systems will be discussed, which may benefit from QC and especially Grover's algorithm.

4.1. Reliability Assessment of Power Systems

In power systems, contingency analysis plays an important role as it supports the operator in identifying events that may cause serious problems for the system. In some cases, the events may shut the system down and, therefore, cause huge financial damage. Therefore, having a solution to evaluate the system and make a contingency analysis allows the grid to have a more secure operation and significantly reduces the risk of extra economical burden as a result of outages of units and blackouts.

To have a contingency analysis, all possible sets of events should be evaluated, and in the case of a high number of components, a large number of scenarios should be considered. Therefore, the contingency analysis can be a time-consuming application. Therefore, considering the most important advantage of the QC, i.e., faster calculations, the implementation of QC for contingency analysis can be very helpful. Previously, some works have been conducted to speed up the contingency analysis using classical methods. Some of those classical methods introduce ways to avoid calculating all possible state of events, and as a result, just some desired event should be considered that can reduce the computational burden and accelerate the contingency analysis. Therefore, if it can be possible to use QC for those classical methods, two speedups can happen. The first one is the speedup due to the classical methods to reduce the number of cases for the evaluation and analysis. In addition, the second speedup is because of the implementation of the QC to run those classical methods.

For a contingency analysis, all possible outages of components in a power system are studied. For more clarification, if a power system has 100 transmission lines, 2^{100} different sets can be defined, in which the members of them are the lines of the power system. For a contingency analysis, one of the sets is selected. Then, the lines that are the members of the selected sets will be removed from the system. Then, a load flow will be calculated to see whether the system can work or not. Therefore, to have a complete contingency analysis, 2^{100} different cases should be considered (in this case, just the outage of lines is considered). It is obvious that, for many cases, there is no need for a contingency analysis. For example, if all of the lines are removed from the system, obviously the system will not work. However, a lot of cases should be considered.

For more clarification, Figure 4 shows a contingency analysis of a power system with 100 lines for $k = 2$.

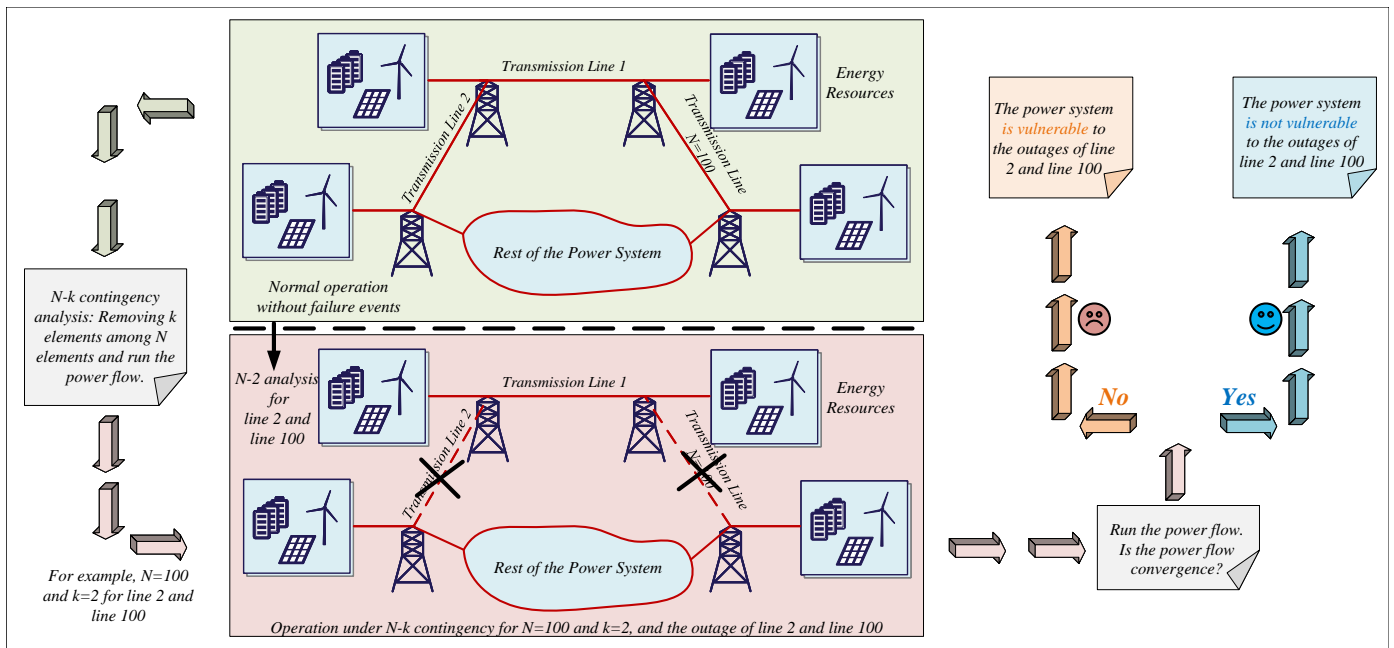

Figure 4. Contingency analysis of a power system with 100 transmission lines under $N - 2$.

4.2. Optimizations in PE Applications

Optimization can be implemented in various types of PE applications. For example, a voltage balancing for DC systems was made in [22] by optimization for a two-phase bipolar DC power system considering power flow, power loss and voltage unbalancing indices. In addition, in [23], a binary optimization has been deployed to solve a unit commitment problem for the short-term operation of systems, including different numbers of units. Furthermore, in [24], a two-stage optimization strategy has been implemented for the placement and sizing of photovoltaic systems. In [24], binary and continuous variables have been used for the location of the photovoltaic system and the power flow, respectively. Furthermore, the optimization strategy of [24] has been organized as a mixed-integer nonlinear programming (MINLP) structure. As another instance, an optimization was performed by [25] for the optimal placement and sizing of an energy storage system in a microgrid. Furthermore, an optimization was deployed by [26] for the optimal placement of distributed generations. In addition, in [27] attempted to have an energy management system for renewable energy resources in multi microgrids, which are integrated by the sources. The implemented method in [27] used a binary particle swarm optimization method to manage the renewable energy resources. In [28], a study was conducted to solve the optimal placement of phasor measurement units (PMUs) in power systems. It is important to note that [28] performed an analysis to minimize the number of PMUs using two binary optimizations, i.e., binary grey wolf and binary bat optimizations. For another example, in [29], a binary particle swarm optimization was used to manage interruptible loads.

As discussed above, optimization can be deployed in different types of systems in PE applications. In addition, in the case of a complex or large-scale system, an optimization can be a time-consuming strategy due to the evaluation of different cases. Therefore, it can be highly recommended to try to use QC. Binary optimization can be a convenient starting point to deploy QC and especially Grover’s algorithm. In a binary optimization, the problem is to find the optimal value of a function, which includes some variables as follows:

$$\min\{h(x_1, x_2, \dots, x_n)\}. \tag{13}$$

where h is the function that should be optimized. Further, n is the number of variables. If each variable has a binary value, it can be 0 or 1. Therefore,

$$x_i \in \{0, 1\} \quad \text{and} \quad i \in \{1, 2, \dots, n\}. \quad (14)$$

Therefore, 2^n different states exist. Therefore, to find the optimal solution, a search space with 2^n members can be evaluated to find the optimal solution. By increasing the number of variables, the search space will be expanded exponentially, and it can make the binary optimization very complex and time-consuming. Therefore, maybe Grover's algorithm can be implemented to solve the optimization problem (due to its ability to find the desired element in an unstructured search space) very faster and find the solution among the search space in a very short time for large-scale PE systems.

4.3. Control of PE Applications

In PE applications, several elements are contained. For example, in a large-scale power system, different types of power sources (e.g., renewable energy resources), loads, energy storage systems (e.g., lithium-ion batteries), one or more buses, transmission or distribution lines, and power electronic-based components, such as power converters, can be included. Due to the scalability of PE applications, control strategies are implemented in them to operate and control them. Control methods can be used for different aspects of PE application, e.g., control of power converters, control of energy resources, control of controllable loads, control of energy storage systems, and control of cooling and heating systems. For example, in [30,31], sensorless control methods were investigated in order to control AC and DC microgrids, respectively. As another example, consensus-based control strategies were implemented by [32–37] for use in DC microgrids. Furthermore, a fuzzy-based application was used in [38] to control hybrid systems, including a fuel cell and a battery in an electric vehicle. Furthermore, a model predictive control-based strategy was deployed in [39] to control a multilevel back-to-back cascaded H-bridge converter. In [40], MPC has been used for dual active bridge DC-DC converters. Furthermore, in [41], MPC was implemented to stabilize DC microgrids with constant power loads.

Based on the above-mentioned examples, there are several types of control strategies, e.g., PI-based method, and MPC-based approaches, which have been used in PE applications. MPC tries to produce proper output signals by predicting the states of the system and the future value of that. MPC can be deployed in different types of applications, e.g., energy management of an electrified powertrain to climate control [42], control of three-phase dual-active-bridge converters [43], control of drive systems [44], control of the energy storage systems [45], improvement of the cybersecurity of DC microgrids [46], and sensorless control of DC microgrids [47]. There are some types of MPC-based controllers, and based on the application, the proper type of MPC can be selected. One of the important types of MPC is finite control set MPC (FCSMPC). A lot of work has been conducted using this type of controller in different applications. For example, in [48], FCSMPC was implemented to control linear induction motors. In addition, in [49] tried to use FCSMPC to control PV systems considering time delay compensation. In [50], FCSMPC was used to control heaving wave energy converters. Furthermore, FCSMPC attempted to control AC-DC converters with an *LCL* filter in [51]. Further, in [52], an FCSMPC-based control approach was introduced for linear induction machines.

In an FCSMPC, the controller tries to predict the future of the system and then produce the proper output signal considering a finite set and selecting the proper values from the finite set. Therefore, in an FCSMPC, the controller can search to find the suitable members or values within the search space to make the best decision and, as a result, produce the proper output signal. Therefore, Grover's algorithm may be implemented to find the desired elements or values. In Figure 5, a general structure related to FCSMPC in a PE application is shown. Typically, power converters provide the opportunity to make renewable energy resources controllable. Based on the switching frequency in a power-based application, each switch can be off (0) or on (1) in each time step. Therefore, based on the existing power converters in a power-based application, if a total of z switches are

operated in the system, in each time step, 2^z different states can happen in the system. For more clarification, if s_j is the state of the j^{th} , switch, then:

$$s_j \in \{1, 0\}, \tag{15}$$

If S_P is the state of the power-based system at P^{th} sampling time, then:

$$S_P \in \{s_1, s_2, \dots, s_j, \dots, s_{z-1}, s_z\}. \tag{16}$$

where S_P can have 2^z different states. Therefore, by increasing the scale of the system and the number of power converters, the number of members in the search space can be increased significantly. In addition, MPC-based strategies are based on prediction and optimization. Therefore, different states of different time steps should be considered to optimize a cost function. Therefore, the MPC-based strategies are time-consuming methods due to predictions of the future and the evaluation of many possible solutions to find the best answer. Therefore, by the implementation of QC, this disadvantage can be corrected. For more clarification, if three variables existed for the FCSMPC, and each variable can only have two possible values, the finite set has eight members. Therefore, if the prediction horizon for the FCSMPC is five, the number of possible states in the search space can be 32,768 different states. Therefore, it can be seen that searching to find the best state among the search space can be very time-consuming. In addition, some applications should be applied within a very short time, even on the scale of between ms and μ s (e.g., for power electronics-based systems such as power converters). Then, if Grover’s algorithm can be implemented, it can be very helpful.

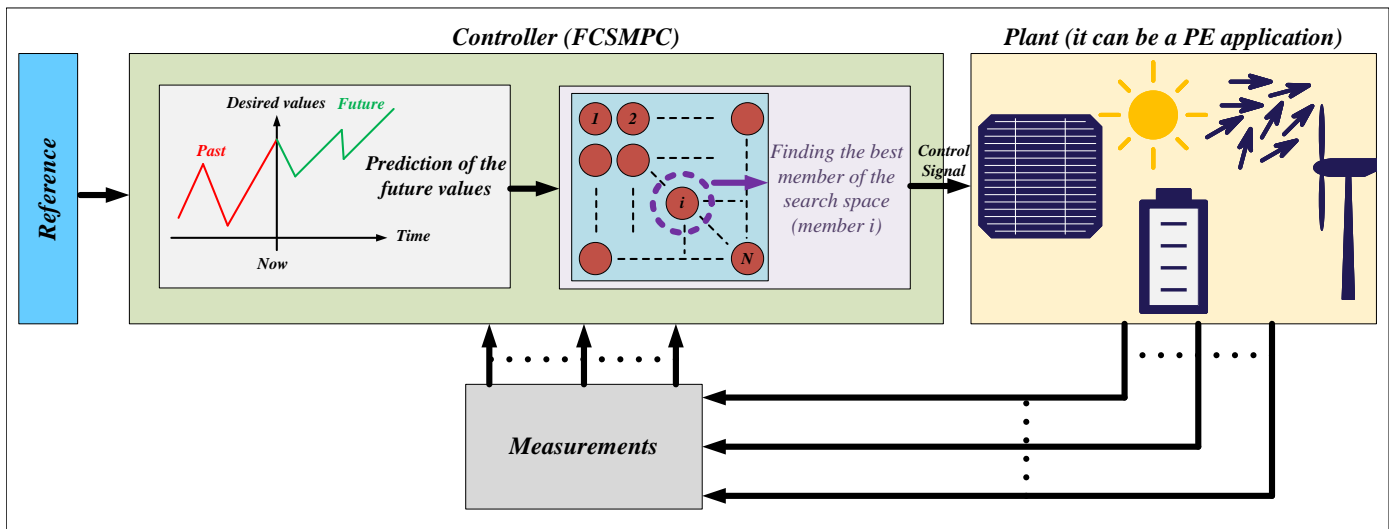

Figure 5. Implementation of FCSMPC in PE applications.

Finally, to conclude this part, a discussion about the existing algorithms in the PE applications and a comparison between them and Grover’s algorithm will be provided. For the reliability assessment of a power system, a search space can be made, which includes all possible events for the outage of one or more components, e.g., transmission lines. Then, those events should be considered one by one to evaluate the system and see the results. Therefore, in the case of a large-scale system, large numbers of events should be studied one by one and in series, which can be a very time-consuming process. In addition, there are some other methods for the contingency analysis of a large-scale system, but it is very hard for them to guarantee the extraction of all possible events, which can result in cascading failures. In other words, by reducing the search space, there is the opportunity that a few or some important events would be missed, which can cause a reduction in the accuracy.

In addition, in the case of model predictive-based control and optimization in a PE application, an optimization process will be used. To solve an optimization problem, and especially in the case of a discrete problem, all possible states can be checked and compared to find the best solution, but in the case of a large-scale system, it needs a long time. Therefore, some methods can be suggested to solve the problem. Typically, to solve these types of problems (i.e., optimization problems), artificial intelligence-based methods can be suggested. However, this type of solution needs to run for some iterations, and it is hard to find the optimal number of iterations. Therefore, usually, a large number of iterations can be used for them, which can directly increase the run time of the process. In addition, sometimes, this type of solution can find the best local state, and as a result, they miss the best global state and solution. Therefore, quantum computing can be used to support the system by accelerating the rate of calculations. In addition, in Grover’s algorithm, a Hadamard gate is used to make an equal superposition for all possible states and allows parallel computing in all possible states, which provides the opportunity to evaluate all possible states faster.

5. Example to Show the Accuracy of Grover’s Algorithm

In this part, an example will be discussed to show the mechanism of Grover’s algorithm. In this example, 12 qubits are considered. Therefore, the search space includes 2^{12} or 4096 states. Therefore, if all the initial qubits are in the state of $|0\rangle$, by applying a Hadamard transform for each qubit, an equal superposition will be made based on (7) as follows:

$$|E\rangle = \frac{1}{\sqrt{4096}} \sum_0^{4095} |x\rangle, \tag{17}$$

or in other words, $|E\rangle$ is a 4096×1 vector as follows:

$$|E\rangle = \begin{bmatrix} \frac{1}{\sqrt{4096}} \\ \frac{1}{\sqrt{4096}} \\ \vdots \\ \frac{1}{\sqrt{4096}} \end{bmatrix}. \tag{18}$$

After the preparation of the equal superposition, the Grover operator should be implemented. The first operator in Grover operator is the oracle. If in this example the problem is to find $|010010001000\rangle$, the oracle works based on (5). In other words, the oracle rotates the phase of the response 180° , and it does not make a change in the phase of the other states [3]. Therefore, the oracle can be a 4096×4096 matrix, where all of the elements on the main diagonal are one except for the element related to the state $|010010001000\rangle$, which can be the 1161st element of the main diagonal. Therefore, the oracle can be written as follows:

$$U_O = \begin{bmatrix} u_1 & 0 & 0 & \cdots & 0 & 0 \\ 0 & u_2 & 0 & \cdots & 0 & 0 \\ 0 & 0 & u_3 & \cdots & 0 & 0 \\ \vdots & \vdots & \vdots & \ddots & \vdots & \vdots \\ 0 & 0 & 0 & \cdots & u_{4095} & 0 \\ 0 & 0 & 0 & \cdots & 0 & u_{4096} \end{bmatrix}. \tag{19}$$

where

$$u_j = \begin{cases} 1 & \text{if } j \neq 1161 \\ -1 & \text{if } j = 1161 \end{cases}. \tag{20}$$

For more clarification and as an example, by the implementation of the oracle for the first iteration and after the oracle (U_O) gate, the state of the system will be as follows:

$$U_O|E\rangle = \begin{bmatrix} \frac{u_1}{\sqrt{4096}} \\ \frac{u_2}{\sqrt{4096}} \\ \vdots \\ \frac{u_{4096}}{\sqrt{4096}} \end{bmatrix}. \tag{21}$$

where u_j is based on (20). Furthermore, in this example, for the rest of the Grover operator, U_{Gr} can be obtained based on (9) as follows:

$$U_{Gr} = H^{\otimes 12}(2|000000000000\rangle\langle 000000000000| - I)H^{\otimes 12}. \tag{22}$$

In addition, $|000000000000\rangle\langle 000000000000|$ can be considered a 4096×4096 matrix, where the only first element of the main diagonal is 1 and the other elements of the matrix are zero, as follows:

$$|000000000000\rangle\langle 000000000000| = \begin{bmatrix} 1 & 0 & 0 & \cdots & 0 & 0 \\ 0 & 0 & 0 & \cdots & 0 & 0 \\ 0 & 0 & 0 & \cdots & 0 & 0 \\ \vdots & \vdots & \vdots & \ddots & \vdots & \vdots \\ 0 & 0 & 0 & \cdots & 0 & 0 \\ 0 & 0 & 0 & \cdots & 0 & 0 \end{bmatrix}. \tag{23}$$

Furthermore, $H^{\otimes 12}$ is a 4096×4096 , and it can produce the following:

$$H^{\otimes 12} = H \otimes H \otimes H \otimes H \otimes H \otimes H \otimes H \otimes H \otimes H \otimes H \otimes H. \tag{24}$$

Further, the Hadamard transformer is [4]

$$H = \frac{1}{\sqrt{2}} \begin{bmatrix} 1 & 1 \\ 1 & -1 \end{bmatrix}. \tag{25}$$

Therefore, based on (19) and (22)–(25), the matrix representation of the Grover operator (G) can be calculated. Furthermore, the Grover operation can be repeated based on (12) $50 (\frac{\pi}{4}\sqrt{4096} = 50.2655)$ times. In this example, $P_S(j)$ and $P_O(j)$ are the probability of the solution and the probability of a non-solution state (e.g., $|100001111000\rangle$) after the j^{th} Grover operator, respectively. To show the effectiveness of Grover’s algorithm, Figures 6 and 7 show the values of $P_S(j)$ and $P_O(j)$ (for $|100001111000\rangle$) for $1 \leq j \leq 50$. Based on Figures 6 and 7, after each iteration of the Grover operator, the probability of the desired solution, that is, state $|010010001000\rangle$, is increased. Furthermore, the probability of $|010010001000\rangle$ after 50 Grover operators is very close to 100%. Based on the results, Grover’s algorithm is successful at finding the solution by making the probability of the solution near 100%.

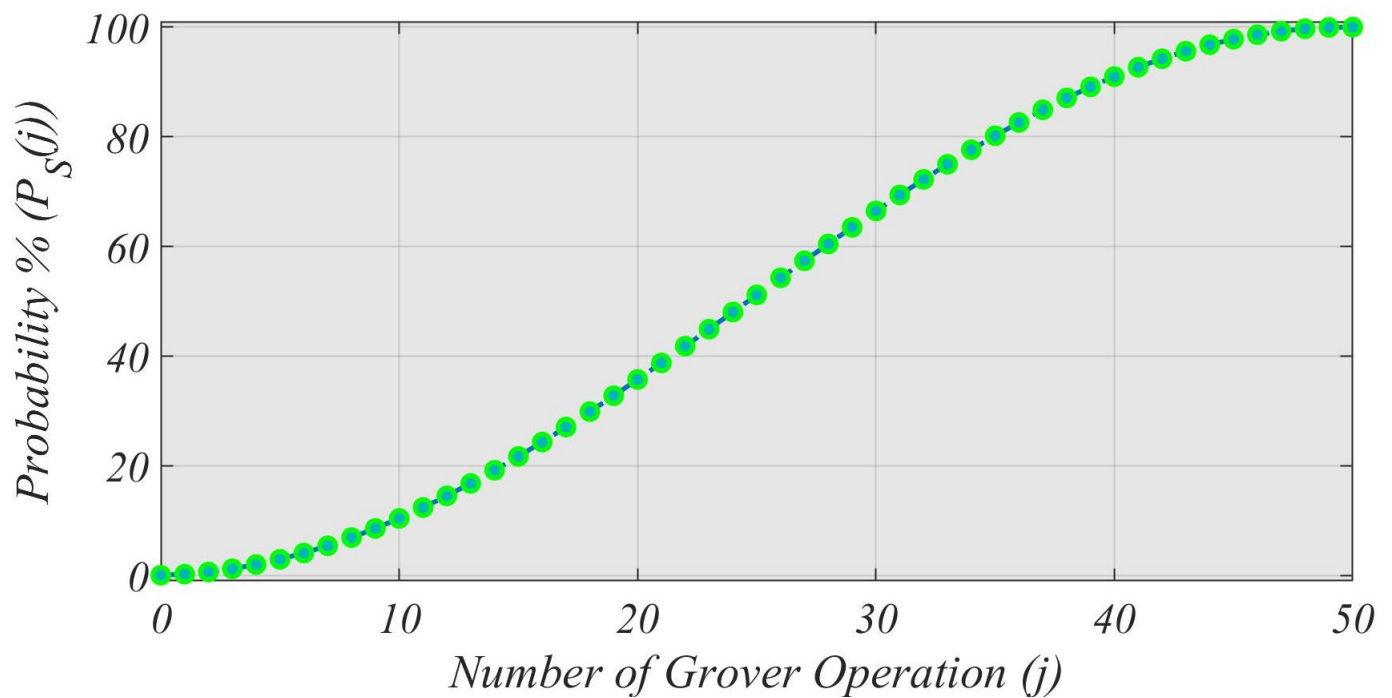

Figure 6. The probability of the state of the solution ($|010010001000\rangle$) after j Grover operator.

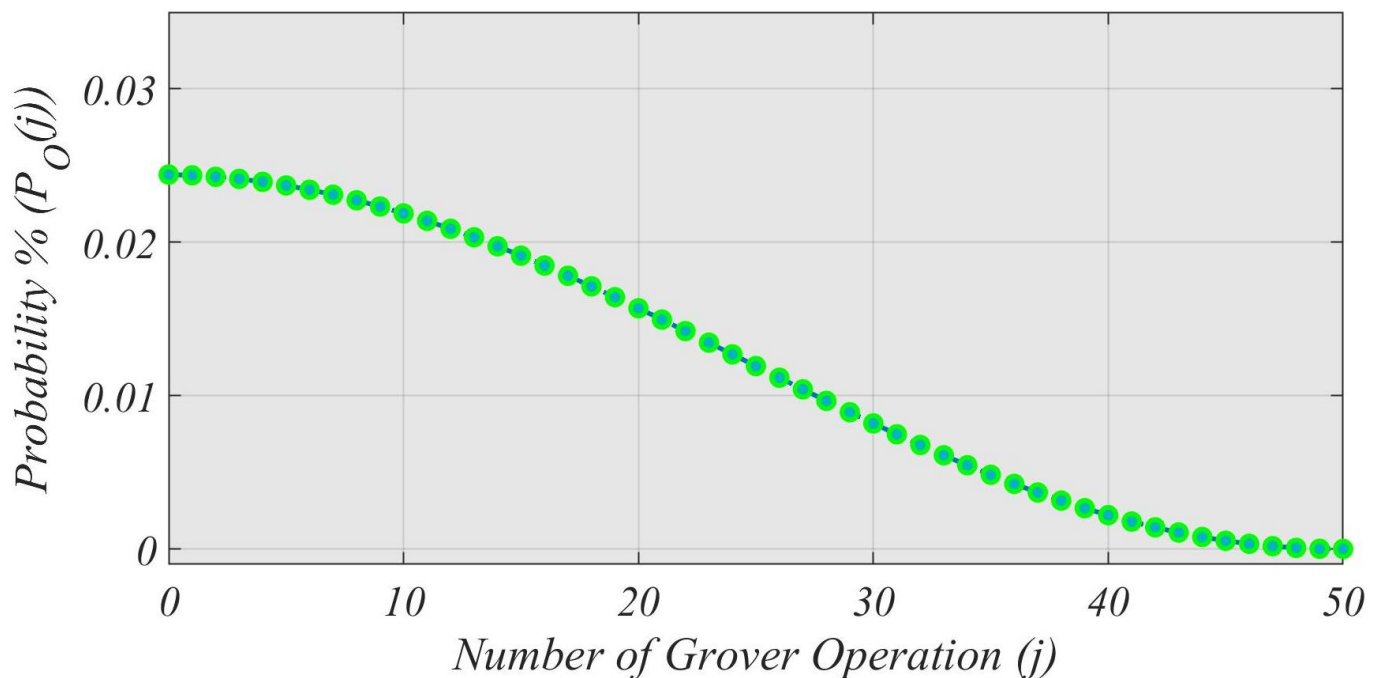

Figure 7. The probability of the state $|100001111000\rangle$ after j Grover operator.

6. Discussion

This paper tried to discuss Grover's algorithm and the possibility of deploying it in a PE application. The implementation of Grover's algorithm can have benefits (i.e., accelerating the rate of calculations by reducing the complexity of the solution) for a PE application. The discussed problems of the PE applications are reliability, optimization, and the control of them. It is important to note that the implementation of Grover's algorithm can have its constraints and difficulties. For example, Grover's algorithm is a quantum computing-based strategy, and a quantum computer can be implemented for

that. Currently, there is limited access to quantum computers. In addition, considering the amount of implemented qubits in quantum computers, it is not possible to use Grover's algorithm for a large-scale problem. Therefore, to use Grover's algorithm and especially for a large-scale system, it is necessary to reach a level of technology that enables a quantum computer with more qubits. Furthermore, one of the main problems in the case of quantum computing is the sensitivity of physical qubits to the environmental noise, which can result in a reduction in the accuracy of the calculations and thus inevitable errors in the calculations. To overcome this issue, two main solutions can be suggested. The first solution is to make physical qubits more isolated from the environment, which is very difficult and expensive. The second solution is to implement some noise calculation or noise cancellation methods, which can support increasing the accuracy of the calculations. In addition, another problem with implementing Grover's algorithm is designing an appropriate oracle. The oracle should have the ability to remark on the desired solution. Furthermore, the technical constraints related to the PE application should be considered in the case of the oracle and Grover's algorithm implementation. The oracle can be considered the main part of Grover's algorithm, and it can be designed based on the studied system and the problems related to that.

7. Conclusions and Future Directions

This paper provided a brief description of QC and one of the important quantum algorithms, i.e., Grover's algorithm. This algorithm can result in a quadratic speedup for unstructured search problems. The possible potential of Grover's algorithm to be implemented in PE applications has been discussed. In this paper, three problems of PE applications (i.e., reliability, optimization, and control) have been discussed. To use Grover's algorithm in PE applications, it is necessary for the desired PE application to be converted to a search problem. In addition, the main core of Grover's algorithm is an oracle, which can be designed based on the constraints of the problem or the problem definition to check different solutions and mark the desired state by changing the phase of the state that is the solution. There are other types of QC-based algorithms, and the potential for them to be implemented in PE applications can be studied and evaluated in future works.

Author Contributions: Writing—original draft preparation, M.R.H.; Writing—review and editing, M.R.H., S.G. and A.S.; Supervision, J.M.G. and J.C.V. All authors have read and agreed to the published version of the manuscript.

Funding: This work was supported by VILLUM FONDEN under the VILLUM Investigator Grant (no. 25920): Center for Research on Microgrids (CROM).

Data Availability Statement: Not applicable.

Conflicts of Interest: The authors declare no conflict of interest.

Appendix A

In this part, the matrix representation of important quantum gates for a single qubit or multiple qubits will be shown. The vector representation of $|0\rangle$ and $|1\rangle$ are, respectively, as follows [4]:

$$|0\rangle = \begin{bmatrix} 1 \\ 0 \end{bmatrix}, \quad (\text{A1})$$

and

$$|1\rangle = \begin{bmatrix} 0 \\ 1 \end{bmatrix}. \quad (\text{A2})$$

In addition, for a single qubit, a Hadamard gate and a Not gate can be represented, respectively, as follows [4]:

$$H = \frac{1}{\sqrt{2}} \begin{bmatrix} 1 & 1 \\ 1 & -1 \end{bmatrix}, \quad (\text{A3})$$

and

$$X = \begin{bmatrix} 0 & 1 \\ 1 & 0 \end{bmatrix}. \quad (\text{A4})$$

Further, a controlled-Not gate and a CZ gate for two qubits are respectively as follows [4]:

$$CX = \begin{bmatrix} 1 & 0 & 0 & 0 \\ 0 & 1 & 0 & 0 \\ 0 & 0 & 0 & 1 \\ 0 & 0 & 1 & 0 \end{bmatrix}, \quad (\text{A5})$$

and

$$CZ = \begin{bmatrix} 1 & 0 & 0 & 0 \\ 0 & 1 & 0 & 0 \\ 0 & 0 & 1 & 0 \\ 0 & 0 & 0 & -1 \end{bmatrix}. \quad (\text{A6})$$

Furthermore, a CCNot gate for three qubits is as follows [4]:

$$CCNot = \begin{bmatrix} 1 & 0 & 0 & 0 & 0 & 0 & 0 & 0 \\ 0 & 1 & 0 & 0 & 0 & 0 & 0 & 0 \\ 0 & 0 & 1 & 0 & 0 & 0 & 0 & 0 \\ 0 & 0 & 0 & 1 & 0 & 0 & 0 & 0 \\ 0 & 0 & 0 & 0 & 1 & 0 & 0 & 0 \\ 0 & 0 & 0 & 0 & 0 & 1 & 0 & 0 \\ 0 & 0 & 0 & 0 & 0 & 0 & 0 & 1 \\ 0 & 0 & 0 & 0 & 0 & 0 & 1 & 0 \end{bmatrix}. \quad (\text{A7})$$

References

1. Benioff, P. The computer as a physical system: A microscopic quantum mechanical Hamiltonian model of computers as represented by Turing machines. *J. Stat. Phys.* **1980**, *22*, 563–591. [\[CrossRef\]](#)
2. Shor, P. Algorithms for quantum computation: Discrete logarithms and factoring. In Proceedings of the 35th Annual Symposium on Foundations of Computer Science, Santa Fe, NM, USA, 20–22 November 1994; pp. 124–134. [\[CrossRef\]](#)
3. Grover, L.K. A Fast Quantum Mechanical Algorithm for Database Search. In Proceedings of the STOC '96: Twenty-Eighth Annual ACM Symposium on Theory of Computing, Philadelphia, PA, USA, 22–24 May 1996; Association for Computing Machinery: New York, NY, USA, 1996; pp. 212–219. [\[CrossRef\]](#)
4. Nielsen, M.A.; Chuang, I. *Quantum Computation and Quantum Information: 10th Anniversary Edition*; Cambridge University Press: Cambridge, UK, 2011.
5. Zhou, Y.; Feng, F.; Zhang, P. Quantum Electromagnetic Transients Program. *IEEE Trans. Power Syst.* **2021**, *36*, 3813–3816. [\[CrossRef\]](#)
6. Feng, F.; Zhou, Y.; Zhang, P. Quantum Power Flow. *IEEE Trans. Power Syst.* **2021**, *36*, 3810–3812. [\[CrossRef\]](#)
7. Zhou, Y.; Zhang, P. Noise-Resilient Quantum Machine Learning for Stability Assessment of Power Systems. *IEEE Trans. Power Syst.* **2022**. [\[CrossRef\]](#)
8. Tang, Z.; Qin, Y.; Jiang, Z.; Krawec, W.O.; Zhang, P. Quantum-Secure Microgrid. *IEEE Trans. Power Syst.* **2021**, *36*, 1250–1263. [\[CrossRef\]](#)
9. Yan, R.; Wang, Y.; Dai, J.; Xu, Y.; Liu, A.Q. Quantum-Key-Distribution-Based Microgrid Control for Cybersecurity Enhancement. *IEEE Trans. Ind. Appl.* **2022**, *58*, 3076–3086. [\[CrossRef\]](#)
10. Tang, Z.; Zhang, P.; Krawec, W.O.; Jiang, Z. Programmable Quantum Networked Microgrids. *IEEE Trans. Quantum Eng.* **2020**, *1*, 1–13. [\[CrossRef\]](#)
11. Nikmehr, N.; Zhang, P.; Bragin, M. Quantum Distributed Unit Commitment. *IEEE Trans. Power Syst.* **2022**, *37*, 3592–3603. [\[CrossRef\]](#)
12. Feng, F.; Zhang, P.; Zhou, Y.; Tang, Z. Quantum microgrid state estimation. *Electr. Power Syst. Res.* **2022**, *212*, 108386. [\[CrossRef\]](#)
13. Soltanmanesh, A.; Shafiee, A. Clausius inequality versus quantum coherence. *Eur. Phys. J. Plus* **2019**, *134*, 282. [\[CrossRef\]](#)
14. Soltanmanesh, A.; Naeij, H.R.; Shafiee, A. Can thermodynamic Behavior of Alice's Particle Affect Bob's particle? *Sci. Rep.* **2020**, *10*, 1–12. [\[CrossRef\]](#) [\[PubMed\]](#)

15. Soltanmanesh, A.; Shafiee, A. Quantum Decoherence in System-Bath Interferometry. *arXiv* **2018**, arXiv:1802.07468.
16. Vinod, G.M.; Shaji, A. Finding Solutions to the Integer Case Constraint Satisfiability Problem Using Grover's Algorithm. *IEEE Trans. Quantum Eng.* **2021**, *2*, 1–13. [[CrossRef](#)]
17. Habibi, M.R.; Baghaee, H.R.; Dragičević, T.; Blaabjerg, F. Detection of False Data Injection Cyber-Attacks in DC Microgrids Based on Recurrent Neural Networks. *IEEE J. Emerg. Sel. Top. Power Electron.* **2021**, *9*, 5294–5310. [[CrossRef](#)]
18. Habibi, M.R.; Baghaee, H.R.; Blaabjerg, F.; Dragičević, T. Secure Control of DC Microgrids for Instant Detection and Mitigation of Cyber-Attacks Based on Artificial Intelligence. *IEEE Syst. J.* **2021**, *16*, 2580–2591. [[CrossRef](#)]
19. Habibi, M.R.; Dragicevic, T.; Blaabjerg, F. Secure Control of DC Microgrids under Cyber-Attacks based on Recurrent Neural Networks. In Proceedings of the 2020 IEEE 11th International Symposium on Power Electronics for Distributed Generation Systems (PEDG), Dubrovnik, Croatia, 28 September–1 October 2020; pp. 517–521. [[CrossRef](#)]
20. Habibi, M.R.; Baghaee, H.R.; Dragičević, T.; Blaabjerg, F. False Data Injection Cyber-Attacks Mitigation in Parallel DC/DC Converters Based on Artificial Neural Networks. *IEEE Trans. Circuits Syst. II Express Briefs* **2021**, *68*, 717–721. [[CrossRef](#)]
21. Habibi, M.R.; Sahoo, S.; Rivera, S.; Dragičević, T.; Blaabjerg, F. Decentralized Coordinated Cyberattack Detection and Mitigation Strategy in DC Microgrids Based on Artificial Neural Networks. *IEEE J. Emerg. Sel. Top. Power Electron.* **2021**, *9*, 4629–4638. [[CrossRef](#)]
22. Chew, B.S.H.; Xu, Y.; Wu, Q. Voltage Balancing for Bipolar DC Distribution Grids: A Power Flow Based Binary Integer Multi-Objective Optimization Approach. *IEEE Trans. Power Syst.* **2019**, *34*, 28–39. [[CrossRef](#)]
23. Kigsirisin, S.; Miyachi, H. Short-Term Operational Scheduling of Unit Commitment Using Binary Alternative Moth-Flame Optimization. *IEEE Access* **2021**, *9*, 12267–12281. [[CrossRef](#)]
24. Montoya, O.D.; Rivas-Trujillo, E.; Hernández, J.C. A Two-Stage Approach to Locate and Size PV Sources in Distribution Networks for Annual Grid Operative Costs Minimization. *Electronics* **2022**, *11*, 961. [[CrossRef](#)]
25. Kim, D.; Yoon, K.; Lee, S.H.; Park, J.W. Optimal Placement and Sizing of an Energy Storage System Using a Power Sensitivity Analysis in a Practical Stand-Alone Microgrid. *Electronics* **2021**, *10*, 1598. [[CrossRef](#)]
26. Katyara, S.; Shaikh, M.F.; Shaikh, S.; Khand, Z.H.; Staszewski, L.; Bhan, V.; Majeed, A.; Shah, M.A.; Zbigniew, L. Leveraging a Genetic Algorithm for the Optimal Placement of Distributed Generation and the Need for Energy Management Strategies Using a Fuzzy Inference System. *Electronics* **2021**, *10*, 172. [[CrossRef](#)]
27. Hannan, M.A.; Abdolrasol, M.G.M.; Faisal, M.; Ker, P.J.; Begum, R.A.; Hussain, A. Binary Particle Swarm Optimization for Scheduling MG Integrated Virtual Power Plant Toward Energy Saving. *IEEE Access* **2019**, *7*, 107937–107951. [[CrossRef](#)]
28. Priyadarshini, S.; Kumar Panigrahi, C. Comparative Analysis between Binary Grey Wolf and Binary Bat Optimization for Optimal PMU Placement with Complete Observability. In Proceedings of the 2020 IEEE International Women in Engineering (WIE) Conference on Electrical and Computer Engineering (WIECON-ECE), Bhubaneswar, India, 26–27 December 2020; pp. 422–425. [[CrossRef](#)]
29. Pedrasa, M.A.A.; Spooner, T.D.; MacGill, I.F. Scheduling of Demand Side Resources Using Binary Particle Swarm Optimization. *IEEE Trans. Power Syst.* **2009**, *24*, 1173–1181. [[CrossRef](#)]
30. Adineh, B.; Habibi, M.R.; Akpolat, A.N.; Blaabjerg, F. Sensorless Voltage Estimation for Total Harmonic Distortion Calculation Using Artificial Neural Networks in Microgrids. *IEEE Trans. Circuits Syst. II Express Briefs* **2021**, *68*, 2583–2587. [[CrossRef](#)]
31. Akpolat, A.N.; Habibi, M.R.; Dursun, E.; Kuzucuoğlu, A.E.; Yang, Y.; Dragičević, T.; Blaabjerg, F. Sensorless Control of DC Microgrid Based on Artificial Intelligence. *IEEE Trans. Energy Convers.* **2021**, *36*, 2319–2329. [[CrossRef](#)]
32. Chen, Z.; Yu, X.; Xu, W.; Wen, G. Modeling and Control of Islanded DC Microgrid Clusters with Hierarchical Event-Triggered Consensus Algorithm. *IEEE Trans. Circuits Syst. I Regul. Pap.* **2021**, *68*, 376–386. [[CrossRef](#)]
33. Shi, M.; Shahidehpour, M.; Zhou, Q.; Chen, X.; Wen, J. Optimal Consensus-Based Event-Triggered Control Strategy for Resilient DC Microgrids. *IEEE Trans. Power Syst.* **2021**, *36*, 1807–1818. [[CrossRef](#)]
34. Wang, B.; Wang, Y.; Xu, Y.; Zhang, X.; Gooi, H.B.; Ukil, A.; Tan, X. Consensus-Based Control of Hybrid Energy Storage System With a Cascaded Multiport Converter in DC Microgrids. *IEEE Trans. Sustain. Energy* **2020**, *11*, 2356–2366. [[CrossRef](#)]
35. Fan, B.; Guo, S.; Peng, J.; Yang, Q.; Liu, W.; Liu, L. A Consensus-Based Algorithm for Power Sharing and Voltage Regulation in DC Microgrids. *IEEE Trans. Ind. Inform.* **2020**, *16*, 3987–3996. [[CrossRef](#)]
36. Cucuzzella, M.; Trip, S.; De Persis, C.; Cheng, X.; Ferrara, A.; van der Schaft, A. A Robust Consensus Algorithm for Current Sharing and Voltage Regulation in DC Microgrids. *IEEE Trans. Control. Syst. Technol.* **2019**, *27*, 1583–1595. [[CrossRef](#)]
37. Du, Y.; Lu, X.; Tang, W. Accurate Distributed Secondary Control for DC Microgrids Considering Communication Delays: A Surplus Consensus-Based Approach. *IEEE Trans. Smart Grid* **2022**, *13*, 1709–1719. [[CrossRef](#)]
38. Chen, J.; Xu, C.; Wu, C.; Xu, W. Adaptive Fuzzy Logic Control of Fuel-Cell-Battery Hybrid Systems for Electric Vehicles. *IEEE Trans. Ind. Inform.* **2018**, *14*, 292–300. [[CrossRef](#)]
39. Gaburro Bacheti, G.; Sartório Camargo, R.; Silva Amorim, T.; Yahyaoui, I.; Frizera Encarnaçao, L. Model-Based Predictive Control with Graph Theory Approach Applied to Multilevel Back-to-Back Cascaded H-Bridge Converters. *Electronics* **2022**, *11*, 1711. [[CrossRef](#)]
40. Guennouni, N.; Chebak, A.; Machkour, N. Optimal Dual Active Bridge DC-DC Converter Operation with Minimal Reactive Power for Battery Electric Vehicles Using Model Predictive Control. *Electronics* **2022**, *11*, 1621. [[CrossRef](#)]
41. Alidrissi, Y.; Ouladsine, R.; Elmouatamid, A.; Errouissi, R.; Bakhouya, M. Constant Power Load Stabilization in DC Microgrids Using Continuous-Time Model Predictive Control. *Electronics* **2022**, *11*, 1481. [[CrossRef](#)]

42. Kibalama, D.; Liu, Y.; Stockar, S.; Canova, M. Model Predictive Control for Automotive Climate Control Systems via Value Function Approximation. *IEEE Control Syst. Lett.* **2022**, *6*, 1820–1825. [[CrossRef](#)]
43. Sun, J.; Qiu, L.; Liu, X.; Zhang, J.; Ma, J.; Fang, Y. Improved Model Predictive Control for Three-Phase Dual-Active-Bridge Converters With a Hybrid Modulation. *IEEE Trans. Power Electron.* **2022**, *37*, 4050–4064. [[CrossRef](#)]
44. Yang, Q.; Karamanakos, P.; Tian, W.; Gao, X.; Li, X.; Geyer, T.; Kennel, R. Computationally Efficient Fixed Switching Frequency Direct Model Predictive Control. *IEEE Trans. Power Electron.* **2022**, *37*, 2761–2777. [[CrossRef](#)]
45. He, J.; Shi, C.; Wei, T.; Jia, D. Stochastic Model Predictive Control of Hybrid Energy Storage for Improving AGC Performance of Thermal Generators. *IEEE Trans. Smart Grid* **2022**, *13*, 393–405. [[CrossRef](#)]
46. Habibi, M.R.; Baghaee, H.R.; Blaabjerg, F.; Dragicevic, T. Secure MPC/ANN-Based False Data Injection Cyber-Attack Detection and Mitigation in DC Microgrids. *IEEE Syst. J.* **2021**, *16*, 1487–1498. [[CrossRef](#)]
47. Akpolat, A.N.; Habibi, M.R.; Baghaee, H.R.; Dursun, E.; Kuzucuoglu, A.E.E.; Yang, Y.; Dragicevic, T.; Blaabjerg, F. Dynamic Stabilization of DC Microgrids using ANN-Based Model Predictive Control. *IEEE Trans. Energy Convers.* **2021**, *37*, 999–1010. [[CrossRef](#)]
48. Xu, W.; Elmorshedy, M.F.; Liu, Y.; Islam, M.R.; Allam, S.M. Finite-Set Model Predictive Control Based Thrust Maximization of Linear Induction Motors Used in Linear Metros. *IEEE Trans. Veh. Technol.* **2019**, *68*, 5443–5458. [[CrossRef](#)]
49. Jin, T.; Shen, X.; Su, T.; Flesch, R.C.C. Model Predictive Voltage Control Based on Finite Control Set With Computation Time Delay Compensation for PV Systems. *IEEE Trans. Energy Convers.* **2019**, *34*, 330–338. [[CrossRef](#)]
50. Jama, M.; Mon, B.F.; Wahyudie, A.; Mekhilef, S. Maximum Energy Capturing Approach for Heaving Wave Energy Converters Using an Estimator-Based Finite Control Set Model Predictive Control. *IEEE Access* **2021**, *9*, 67648–67659. [[CrossRef](#)]
51. Falkowski, P.; Sikorski, A. Finite Control Set Model Predictive Control for Grid-Connected AC–DC Converters With LCL Filter. *IEEE Trans. Ind. Electron.* **2018**, *65*, 2844–2852. [[CrossRef](#)]
52. Elmorshedy, M.F.; Xu, W.; Allam, S.M.; Rodriguez, J.; Garcia, C. MTPA-Based Finite-Set Model Predictive Control Without Weighting Factors for Linear Induction Machine. *IEEE Trans. Ind. Electron.* **2021**, *68*, 2034–2047. [[CrossRef](#)]