

2022

A Heuristic Model Predictive Control Method to Activate the Energy Flexibility of School Buildings

Navid Morovat

Andreas K Athienitis

José Agustín Candanedo

Follow this and additional works at: <https://docs.lib.purdue.edu/ihpbc>

Morovat, Navid; Athienitis, Andreas K; and Candanedo, José Agustín, "A Heuristic Model Predictive Control Method to Activate the Energy Flexibility of School Buildings" (2022). *International High Performance Buildings Conference*. Paper 411.
<https://docs.lib.purdue.edu/ihpbc/411>

This document has been made available through Purdue e-Pubs, a service of the Purdue University Libraries. Please contact epubs@purdue.edu for additional information. Complete proceedings may be acquired in print and on CD-ROM directly from the Ray W. Herrick Laboratories at <https://engineering.purdue.edu/Herrick/Events/orderlit.html>

A Heuristic Model Predictive Control Method to Activate the Energy Flexibility of Electrically-Heated School Buildings

Navid Morovat^{1*}, Andreas K. Athienitis¹, José Agustín Candanedo^{1,2}

¹Concordia University, Centre for Zero Energy Building Studies,
Montréal, Québec, Canada
n_morova@encs.concordia.ca, andreask.athienitis@concordia.ca

²CanmetENERGY,
Varenes, Québec, Canada
jose.candanedoibarra@canada.ca

* n_morova@encs.concordia.ca

ABSTRACT

This paper presents a methodology to model and activate the energy flexibility of electrically-heated school buildings using a heuristic model predictive control approach. The heuristic model predictive control method is developed based on data-driven grey-box models for archetype thermal zones in school buildings. The archetype zones include the zones with convective systems (e.g., classrooms, library, and kindergarten). A third-order RC network for classrooms is developed and calibrated using measured data from an archetype school building. The winter peak load in Québec (Canada) significantly strains the electrical grid. Therefore, very cold and cold winter days are clustered into three categories depending on the one-day-ahead weather prediction: sunny, semi-cloudy/intermediate, and cloudy days. Heuristic setpoint profiles are selected to achieve the optimal zone temperature profile based on forecasted weather scenarios while considering the thermal comfort of the occupants. Key performance indicators are applied to quantify the energy flexibility at the school building. The case study school (located in Québec, Canada) is an electrically-heated building with geothermal heat pumps, radiant floors, and energy storage. Preliminary results show that with an appropriate heuristic model predictive control strategy, the zones with the convective system can provide energy flexibility of 47% during on-peak hours relative to a reference as-usual profile.

1. INTRODUCTION

The share of renewable energy sources (RES) increases in parallel with extensive electrification of the energy demand. The large-scale deployment of intermittent RES could adversely affect the operation and stability of the grid. In Québec, winter's morning and evening peak load significantly strain the electrical grid, while photovoltaic (PV) electricity production peaks around noon. Therefore, controlling energy use is essential to reduce the mismatch between supply and demand (Afroz *et al.*, 2018; Klein *et al.*, 2017; Morovat *et al.*, 2019). Recently, Québec awarded a 25-year contract to power New York State (HydroQuebec, 2021), and there has been another contract with Massachusetts since 2019 (HydroQuebec, 2019). These contracts mean the province needs to emphasize load management in buildings more. In this context, energy flexibility is critical to addressing the grid's challenges of (a) balancing supply and demand and (b) incorporating renewable energy capacity. Energy flexibility is defined as "the ability to manage demand and generation according to local climate conditions, user needs, and grid requirements." The role of buildings as flexible loads is increasingly recognized as a key component of electricity grids; they can act as energy generators, energy storage devices, and controllers of demand. A study by Choi *et al.* (2012) revealed that the best level of energy savings cannot always be achieved just by implementing new energy-saving technologies. They found that energy management strategies could be more effective than energy-saving technologies.

Commercial buildings are typically the focus of studies evaluating buildings' energy performance (Azar *et al.*, 2012; Mulville *et al.*, 2014), but few studies have been focused on school buildings in Canada. There are over 15,500 schools in Canada, with more than 5 million students and nearly 700,000 teachers and other employees (Statistic

Canada, 2017). Ouf *et al.* (2017) found that school buildings' median total energy consumption is higher than other similar Canadian benchmarks. Thus, quantification of energy flexibility in school buildings has a significant role in providing a safe and efficient operation of the future resilient grid.

Therefore, we need to develop models for school buildings that provide reliable predictions and can be generalized for widespread deployment in schools. Classical control techniques such as thermostat control (On/Off control with predefined setpoints and PID control) are popular in Building Energy Management Systems (BEMS). These controllers react to changes in weather and occupancy conditions without making any predictions. These approaches are suitable for fast responding local loops. However, they fail to efficiently control slow responding dynamic processes (e.g., radiant floor systems used for energy storage) (Afram *et al.*, 2014). Medium and large commercial buildings usually have significant thermal mass in exposed concrete or tiled concrete floors. Thus, anticipatory controls can be beneficial since they address the delay between the supplied heating/cooling and its effect on the indoor temperature (Ruusu *et al.*, 2019). MPC can enable programming the building operation based on future weather and occupant behavior. The proactive "look ahead" approach of MPC makes it possible to optimize the building operation, resulting in significant improvements in energy flexibility, IEQ, load management, and building-grid interaction.

Predictive control strategies can be classified into two types: 1) rule-based model predictive control (RBMPC), which is a Near-optimal approach; 2) model-based predictive control (MPC), which is a "proper" MPC, based on a formal mathematical optimization (O'Brien *et al.*, 2015). The first approach is typically used for actual implementations since formulating an optimization problem in real-time is challenging. Load shifting with fixed scheduling is the most common form of rule-based control to maximize energy flexibility (Carvalho *et al.*, 2015; Lee *et al.*, 2015).

This paper presents a heuristic model predictive control approach to model and activate the energy flexibility of electrically-heated school buildings in cold climate regions. The study consists of four components:

- Developing grey-box models and calibration of these models with real data,
- Clustering forecasted weather data based on the outdoor temperature and solar irradiance,
- Testing of different control scenarios to assess the impact on electricity demand and energy performance,
- Energy flexibility quantification to enable interaction between buildings, aggregators, and utilities.

2. Case study: Electrically-heated school building

An electrically-heated school building (Horizon-du-Lac) located near Montréal, Canada (45°31'N 73°56'W), was considered as a case study (Figure 1). It is a two-floor school building with twenty classrooms, five offices, one gym, one kindergarten, one kitchen, and one meeting room as shown in Figures 2 and 3.



Figure 1: Horizon-du-Lac school building in a winter cold cloudy day



Figure 2: Plan view of the first floor (zones with convective system are highlighted)

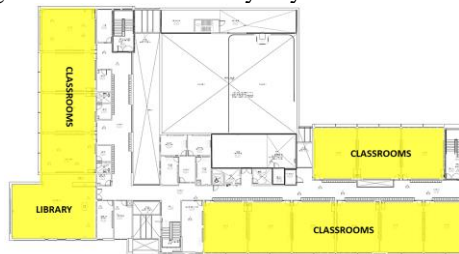

Figure 3: Plan view of the second floor (zones with convective system are highlighted)

This study was conducted in a school with geothermal heat pumps, radiant floors, and energy storage systems. A geothermal water-water HP can provide 24 kW of heating, a high-temperature thermal storage device can store 80 kW of heating, and 36 water-air HPs can generate 182 kW of heating. Proportional-Integral control (PI) is used in the local-loop control of room air temperature. All heating systems are electrical devices and hence provide a link with the electrical grid. A predictive controller can exploit this link to help balance electricity production and demand, among other potential uses. Figure 4 presents the schematic of the building heating systems.

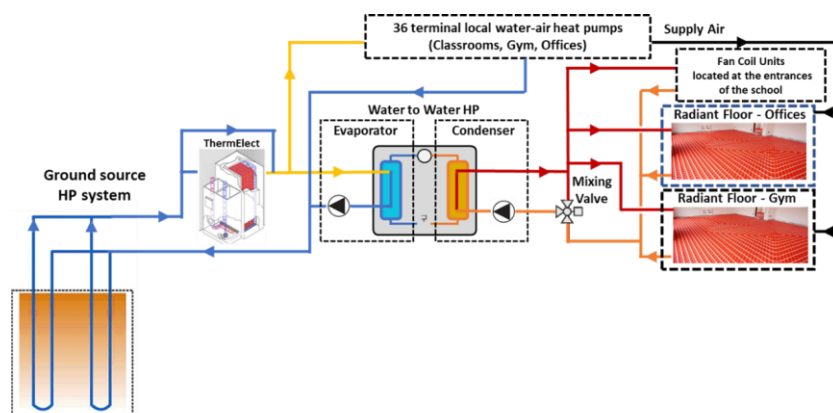

Figure 4: Process flow diagram (PFD) of the building heating systems.

3. METHODOLOGY

The heuristic MPC routine proposed in this paper includes collecting input data, developing an archetype data-driven grey-box model, clustering the weather forecasts with a prediction horizon of 24 h, developing heuristic model predictive control strategies, and quantifying energy flexibility and energy efficiency (Figure 5).

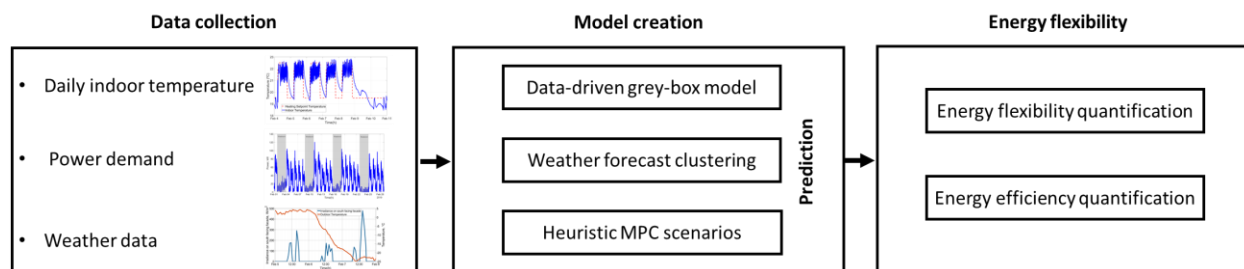

Figure 5: Model structure – Data collection, predicting, and energy flexibility quantification

2.1 Data-Driven Grey-Box Modelling

Proper identification of building thermal models with adequate resolution, robust, and acceptable computation time is fundamental for implementing MPC or other advanced control strategies in building automation systems. Reducing features to those that are most relevant can deliver the following gains:

- Improved performance.
- Reduced complexity.
- Improved interpretability of the developed models.

The grey box model structures are derived from resistance-capacitance (RC) networks analogy to electric circuits to describe the dynamics of the systems. Grey-box models rely on physical knowledge about the system dynamics to define the model structure (i.e., the layout of RC parameters). Optimization methods are then used to estimate the unknown parameters. These models are an integral part of the heuristic MPC method. By performing a heat balance on the control volume, the differential equation can be written as equation 1:

$$C_i \frac{dT_i}{dt} = Q_i + \sum_{i,j}^n \frac{(T_j - T_i)}{R_{i,j}} \quad (1)$$

Each node solves its energy balance using a fully explicit finite difference approach, in which the conditions determine the current temperature at the previous time step. The time derivative term is discretized as follows:

$$C_i \frac{dT_i}{dt} \approx C_i \frac{\Delta T_i}{\Delta t} = C_i \frac{(T_i^{t+1} - T_i^t)}{\Delta t} \quad (2)$$

Temporal discretization of Equation (1) can be rearranged in the following explicit manner:

$$T_i^{t+1} = \frac{\Delta t}{C_i} \left[\sum_j U_{ij}^t (T_j^t - T_i^t) + \sum_k U_{ik}^t (T_k^t - T_i^t) + \frac{C_i}{\Delta t} (T_i^t) + \dot{Q}_i^t \right] \quad (3)$$

Where $R_{i,j}$ is the thermal resistance between nodes, Q_i is the heat source generation at a node, T is the temperature of a node, and C is the thermal capacitance of a node. Using statistical indices, such as the Coefficient of Variance of Root Mean Squared Error (CV-RMSE), model predictions are compared to measurements, and RC parameters are identified. The details of the governing equations are presented in (O'Brien & Athienitis, 2015).

2.2 Weather data clustering

This paper implements a centroid-based approach (K -means clustering) in Python to classify weather prediction into sunny, semi-cloudy, and cloudy days. The forecasts were obtained using CanMETEO® a free program developed by Natural Resources Canada (NRCan, 2021). An illustration of the K -means clustering algorithm is shown in Figure 6.

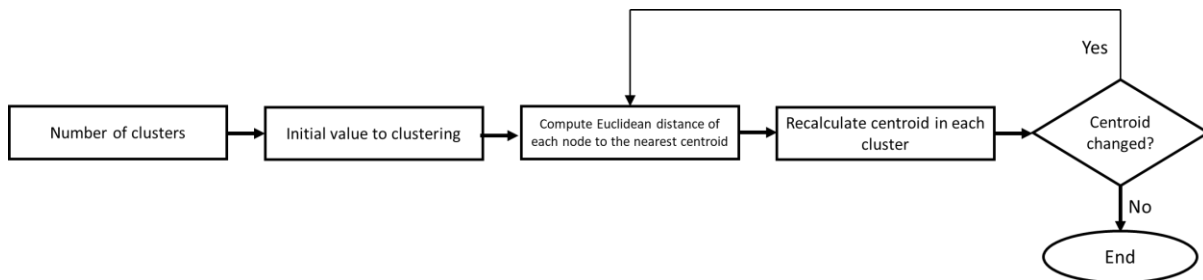

Figure 6: K -means clustering algorithm flowchart

The first step in K -means clustering is selecting the number of clusters (K). Then, K time-series data points are randomly selected from the data set to serve as the initial centroids for clusters. Each data point is assigned to a cluster based on its closest centroid. In the third step, a new centroid for each cluster is calculated. Once the centroids are recalculated, each data point is examined for closer proximity to a different centroid (a new cluster assignment). Cluster assignment and centroid updating are repeated until the cluster assignments stop changing.

2.3 Rule-based model predictive control

MPC is a control method that includes a dynamic model of the system to be controlled, forecasts of future disturbances (such as weather, occupancy), and a cost function that is minimized over a prediction horizon. Figure 7 provides a representation of the rule-based MPC approach which is used in this study.

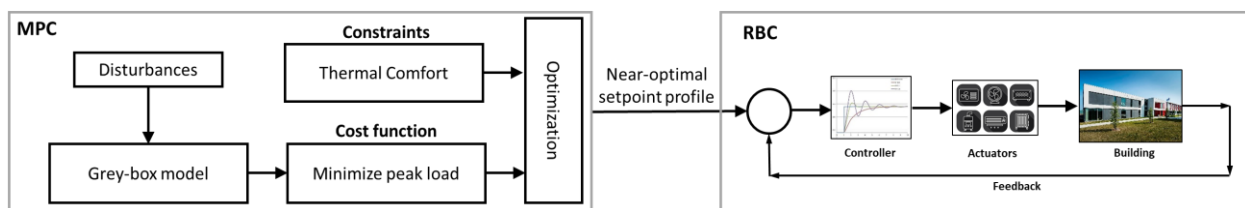

Figure 7: Conceptual representation of the rule-based model predictive Control (RBMPC)

The optimal control problem in MPC is solved by looking ahead at forecast disturbances (e.g., weather) over the prediction horizon. The prediction horizon is a period that has reasonably reliable information about the future, ranging from a few hours to a few days. An optimization routine is solved using data from the prediction horizon period, and an optimal sequence of control moves is identified through MPC implementation. A "control horizon" is applied to the building to determine schedules and controls. The objective function of the controller is to minimize a cost that may include energy and power while maintaining the thermal comfort of occupants. Equation 4 describes the general MPC framework; some describe the system's dynamics for control, while others define limits and boundary conditions.

$$\begin{aligned}
 J &= \min_{u^0, \dots, u^{N-1}} \sum_{t=0}^{N-1} l(x^t, u^t, w^t) \\
 &\text{subject to } h_i(x^t, u^t, w^t) = 0, i \in \{1, \dots, m\}, \text{equality constraints} \\
 &g_j(x^t, u^t, w^t) \geq 0, j \in \{1, \dots, n\}, \text{inequality constraints} \\
 &x^0 = x, \text{ current state} \\
 &x^{t+1} = f(x^t, u^t, w^t) = Ax^t + Bu^t + Ew^t, \text{ system dynamics}
 \end{aligned} \tag{4}$$

Where,

- x^t system variables track the system dynamics,
- u^t control variables which can be manipulated in order to improve the building performance,
- w^t exogenous inputs that can be observed but cannot be controlled, such as weather,
- $l(x, u, w)$ cost function, which could be to minimize the utility cost or the grid interaction.
- $h(x, u, w) = 0$ equality constraints; the system dynamics of the system are given by the trained model,
- $g(x, u, w) \geq 0$ inequality constraints; here, the inequality constraints are the boundaries of the problem.

2.1 Energy Flexibility Indicators

A building Energy Flexibility Index would help define the amount of power variation available from a building (Finck *et al.*, 2020). In this paper, energy flexibility has been calculated based on Equation (5). This Equation calculates the average BEFI under implementing the flexibility strategy and the reference as-usual profile. We presented the details of this index in (Athienitis *et al.*, 2020).

$$\overline{BEFI}(t, Dt) = \frac{\int_t^{t+Dt} P_{ref} dt - \int_t^{t+Dt} P_{flex} dt}{Dt} \tag{5}$$

The calculation of the BEFI as a percentage compares the peak power under the flexible case and the reference as usual profile (Equation 6).

$$BEFI\% = \frac{P_{ref} - P_{Flex}}{P_{ref}} \tag{6}$$

4. RESULTS AND DISCUSSION

4.1 Model development

The measured data (room temperatures, historical weather data, and power demand) were used to calibrate an archetype grey-box model of the zones with convective systems. The third-order model, shown in Figure 8, is a resistance-capacitance (RC) thermal network with three capacitances. In this model, C_1 represents the envelope capacitance, C_2 the air capacitance, C_4 the floor capacitance, $R_{1,ext}$ the thermal resistance between the envelope and the exterior air, $R_{2,ext}$ the thermal resistance between the interior and exterior air, $R_{1,2}$ the thermal resistance between the envelope and the interior air, and $R_{2,3}$ the thermal resistance between the interior air and the floor.

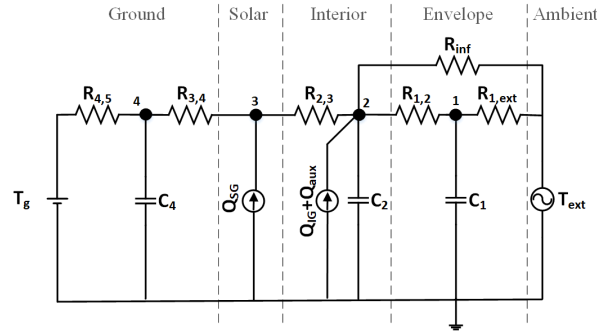

Figure 8: Thermal network model of the zones with convective system

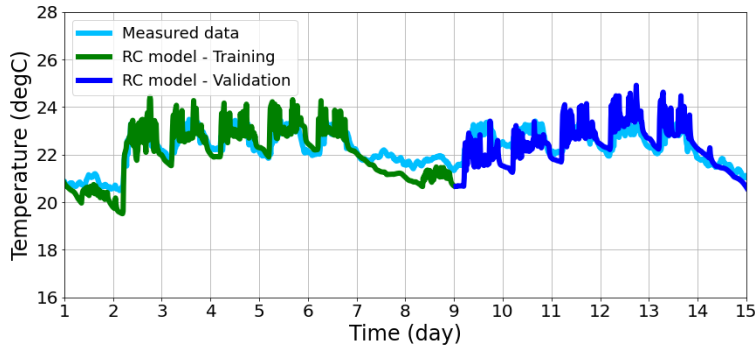

Figure 9: Calibration of thermal network model with measured data

The measured data from February 1st to February 15th were used for model learning (Figure 9). The dataset was divided into two datasets: 60% of the dataset was used for training, while 40% was kept for validation purposes. The performance of models was assessed by comparing model predictions with BAS measurements. The accuracy was evaluated in terms of coefficient of variance of the root mean square error (CV-RMSE) as a fit metric. In accordance with ASHRAE Guideline 14, the model should not exceed a CV-RMSE of 30% relative to hourly measured data (ASHRAE Guideline 14, 2002). By minimizing CV-RMSE, the optimization algorithm determines the equivalent parameters for RC circuits.

4.2 Weather forecast

Weather data for Montreal's coldest months (January and February) are selected because peak energy demand occurs under these conditions. The historical weather data is obtained from the hourly Montreal weather file [32]. *K*-means clustering is performed for the solar irradiance (SI) and outdoor temperature data, and the Silhouette index is used to determine the clustering quality. With this indicator (ranging between +1 and -1), the clustering quality is assessed according to how well data points fit within the cluster. Clusters with an average silhouette index close to 1 are dense and well-separated; negative values indicate that the dataset may have been grouped incorrectly. The number of clusters (within a specific range) that maximizes the average Silhouette is considered the optimal value. As shown in Figure 10 and 12, the average Silhouette index for the solar radiation shows three and for outdoor temperature shows two clusters as the optimal number of clusters.

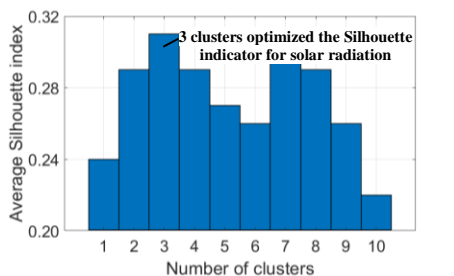

Figure 10: Average Silhouette index for the solar radiation

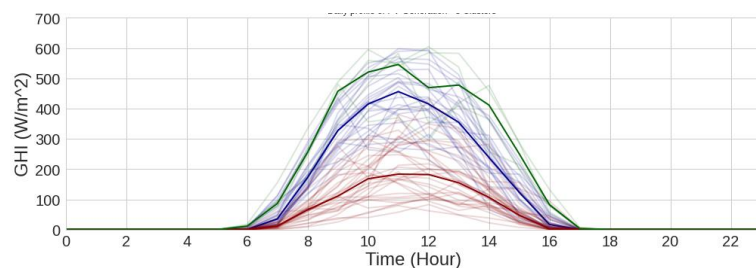

Figure 11: Three clusters and the corresponding solar radiation

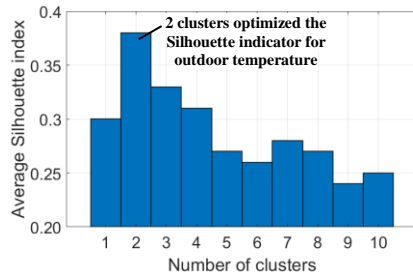

Figure 12: Average Silhouette index for the outdoor temperature

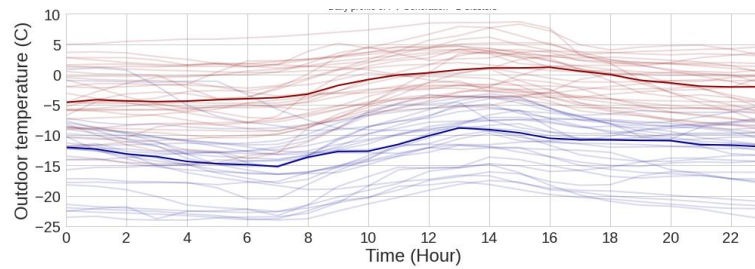

Figure 13: Two clusters and the corresponding outdoor temperature

Thus, the possible expected weather conditions are clustered into six possible categories. A predictive setpoint profile is developed with a target for each scenario to maximize energy flexibility. Table 1 presents weather forecast scenarios clustered based on the outdoor temperature and solar irradiance.

Table 1: Weather prediction classification

Ambient Temperature	Cloudiness		
	Sunny ($SI > 500 \text{ W/m}^2$)	Semi-cloudy ($250 < SI < 500 \text{ W/m}^2$)	Cloudy ($SI < 250 \text{ W/m}^2$)
Very cold day ($T_{\text{avg}} = -12.5 \text{ }^\circ\text{C}$)	Scenario 1	Scenario 2	Scenario 3
Cold day ($T_{\text{avg}} = -2.5 \text{ }^\circ\text{C}$)	Scenario 4	Scenario 5	Scenario 6

The developed model runs a simulation using forecast weather data for each scenario to estimate the associated electricity consumption over the next 24 h. The setpoint profile yielding the lowest peak load during on-peak hours is selected as the optimal control strategy for energy flexibility.

4.3 Heuristic MPC routine

Once the building model is appropriately developed, a set of setpoint profiles can be defined with an objective function. The objective of the proposed MPC is the peak load reduction in electrically-heated school buildings. Overall, this approach aims to provide a general methodology for load management in commercial and institutional buildings, thus facilitating replicability in other buildings.

The MPC routine consists of the following steps:

1. The control-oriented model estimates the building heating demand for all the considered pre-defined setpoint profiles (Figure 14).
2. Weather forecasts with a prediction horizon of 24 h, derived from CanMETEO[®] (developed by Natural Resources Canada).
3. Weather forecasts are clustered and used along with the control-oriented model to estimate the building heating demand for all the considered predefined set-point profiles.
4. The setpoint profile achieving the lowest peak load is identified as a “near-optimal control strategy” for energy flexibility.
5. The next day, the building is operated under the identified optimal control set-point.

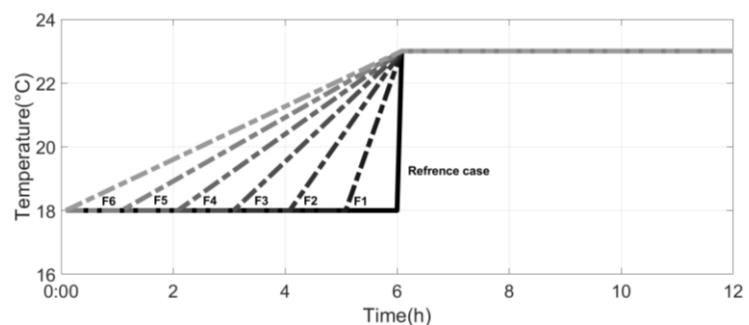

Figure 14: Predefined set-point profiles in early morning

The considered pre-defined setpoint profiles could be applied to most commercial and institutional buildings, as these buildings are usually occupied during the same period of the day, from 8:00 to 17:00, while considering thermal comfort.

4.4 Energy Flexibility

Quebec's utility rates include fees for power consumption and demand. Because of this, customers are seeking to reduce energy consumption and adequately manage their power use. Customers can enroll in a Demand Response (DR) Program during peak winter times to get financial assistance to reduce their building's demand. In order to assess the peak load reduction from the MPC implementation, benchmarking models of the building loads under business-as-usual control were developed (Figures 15a and 16a). These benchmarking models predict the daily power demand using the outdoor air temperature and solar radiation as inputs. The observed trend was studied by running the control-oriented models with weather data corresponding to two different days of the MPC implementation period: a) a very cold day ($-12.5\text{ }^{\circ}\text{C}$ average daily OAT) and b) a cold day ($-2.5\text{ }^{\circ}\text{C}$ average daily OAT). Six predefined profiles were tested on both day clusters. For example, Figures 15b and 16b present power demand for very cold days and cold days under a set-point profile with a four-hour transition ramp.

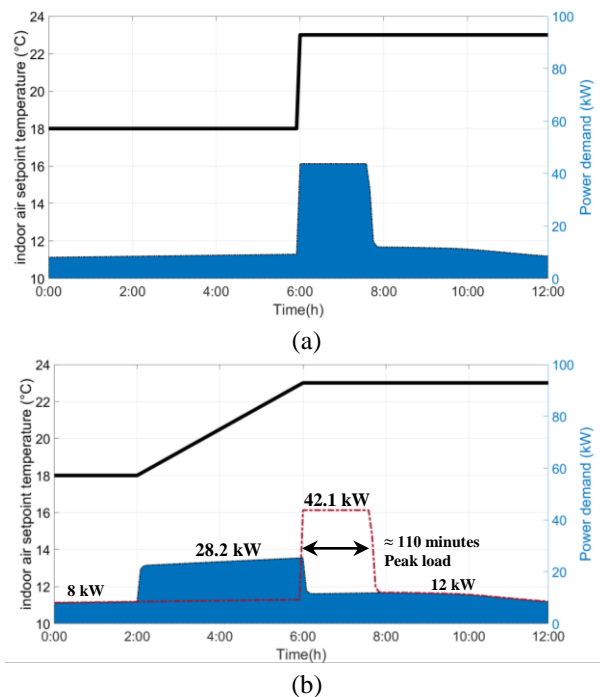

Figure 15: Power demand during very cold sunny days (Daily average OAT = $-12\text{ }^{\circ}\text{C}$) with a) Step-change, b) 4-hour ramp in setpoint temperature

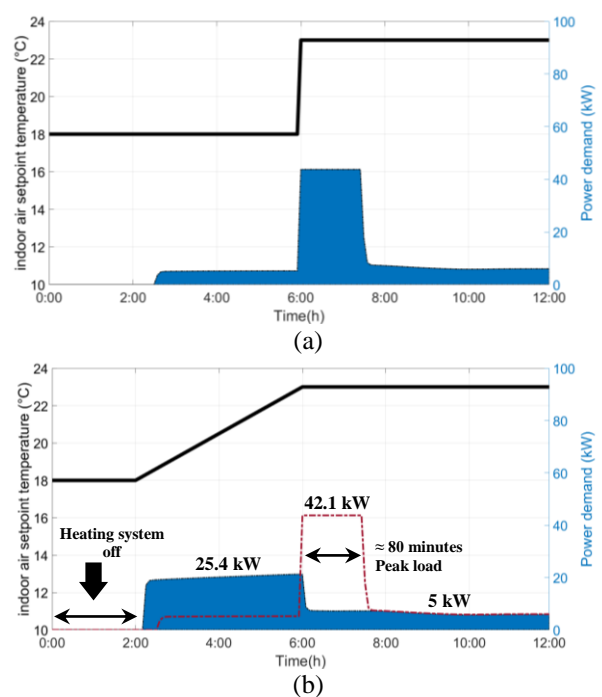

Figure 16: Power demand during cold cloudy days (OAT = $-2\text{ }^{\circ}\text{C}$) with a) Step-change, b) 4-hour ramp in setpoint temperature

In the case of the very cold and cold days, simulations showed that when the outdoor air temperature is very low, it is beneficial to maintain a lower night set-back value to avoid peak load during on-peak hours. An almost flat setpoint allows shifting the building heating load from the on-peak hour to the off-peak hours (nighttime). Furthermore, MPC improved occupants' thermal comfort by gradually increasing the indoor temperature during the night, rather than applying abrupt set-point variations just before occupancy starts.

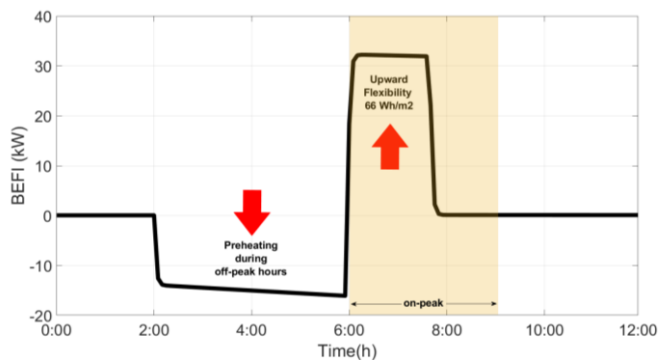

Figure 17: Average hourly BEFI – Flexible scenario with four hours ramp

As can be observed in Figure 17, by applying four hours ramp, the available hourly BEFI that can be provided to the grid during peak hours is positive, which indicates the value of power reduction available compared to the reference case. During off-peak hours (nighttime), the BEFI is negative, showing a higher power demand for preheating the zones. According to Figure 19, energy flexibility of around 66 W/m² in the during morning on-peak hours can be provided to the grid.

Table 2: BEFI and energy efficiency for proposed control strategies

Control Scenario	Peak load (kW)	BEFI (%)	Energy consumption (kWh)	Energy efficiency (%)
Reference case	42.1 kW	(-)	173.9	-
1-hour ramp (F1)	42.1 kW	(0 %)	174.5	- 0.34
2-hour ramp (F2)	39.2 kW	(6 %)	175.8	- 1.09
3-hour ramp (F3)	31.5 kW	(25 %)	176.4	- 1.43
4-hour ramp (F4)	25.4 kW	(39%)	177.9	- 2.30
5-hour ramp (F5)	24.1 kW	(42 %)	178.7	- 2.81
6-hour ramp (F6)	22.2 kW	(47 %)	179.9	- 3.45

According to table 2, with notification from the utility to the customer given at midnight (6 hours ahead of an event at 6 AM), a BEFI of 47% can be achieved. Depending on the utility rate structure, the peak demand during critical event hours can be reduced by 20 kW for 3 hours. A relatively short notification time of 3 hours also allows MPC to reduce peak demand during the critical hours by 25 percent and achieve a BEFI of 10.4 kW for 3 hours. In general, this approach provides a method for load management in commercial and institutional buildings, which can be replicated in other buildings. In the future work, the MPC strategy developed and presented in this paper will be improved by integrating constraints on building power demand into the objective function of the MPC routine and by considering additional indoor setpoint profiles when aiming for optimal control.

5. CONCLUSIONS

The development of control-oriented rule-based models for MPC applications requires less time, information, and technical expertise than an approach based on proper MPC. This paper presented the heuristic model-based prediction control strategies applied to an archetype electrically heated school building. Results show that rule-based MPC can be a successful alternative to the fully optimized MPC to significantly improve energy flexibility and enhance load management while eliminating the cost of modeling. Compared to simple rule-based controls, it comprises the building model, thus considering the thermal behavior under the anticipated weather conditions and taking near-optimal actions to benefit from that information maximally. This approach provides a general methodology for load management in commercial and institutional buildings, enabling replicability in other buildings.

NOMENCLATURE

<i>BEFI</i>	Building Energy Flexibility Index (W)	<i>R</i>	Thermal resistance (K/W)
<i>C</i>	Thermal capacitance (J/K)	RES	Renewable energy sources
<i>Dt</i>	Time (seconds/hours)	<i>T</i>	Temperature (°C)
<i>J</i>	Objective function	<i>T_{SP}</i>	Setpoint temperature (°C)
<i>P</i>	Electric power (W)	<i>x</i>	state

REFERENCES

- Afram, A., & Janabi-Sharifi, F. (2014). Theory and applications of HVAC control systems—A review of model predictive control (MPC). *Building and Environment*, 72, 343-355.
- Afroz, Z., Shafiullah, G., Urmee, T., & Higgins, G. (2018). Modeling techniques used in building HVAC control systems: A review. *Renewable and Sustainable Energy Reviews*, 83, 64-84.
- ASHRAE Guideline 14. (2002). Guideline 14-2002, Measurement of energy and demand savings. *American Society of Heating, Ventilating, and Air Conditioning Engineers, Atlanta, Georgia*.
- Athienitis, A. K., Dumont, E., Morovat, N., Lavigne, K., & Date, J. (2020). *Development of a dynamic energy flexibility index for buildings and their interaction with smart grids*. Paper presented at the 2020 Summer Study on Energy Efficiency in Buildings, California, USA.
- Azar, E., & Menassa, C. C. (2012). A comprehensive analysis of the impact of occupancy parameters in energy simulation of office buildings. *Energy and Buildings*, 55, 841-853.
- Carvalho, A. D., Moura, P., Vaz, G. C., & de Almeida, A. T. (2015). Ground source heat pumps as high efficient solutions for building space conditioning and for integration in smart grids. *Energy Conversion and Management*, 103, 991-1007.
- Choi, I. Y., Cho, S. H., & Kim, J. T. (2012). Energy consumption characteristics of high-rise apartment buildings according to building shape and mixed-use development. *Energy and Buildings*, 46, 123-131.
- Finck, C., Li, R., & Zeiler, W. (2020). Optimal control of demand flexibility under real-time pricing for heating systems in buildings: A real-life demonstration. *Applied energy*, 263, 114671.
- HydroQuebec. (2019). Retrieved from <https://www.hydroquebec.com/clean-energy-provider/markets/new-england.html#:~:text=Further%20to%20a%20clean%20energy,state's%20regulatory%20authorities%20in%202019>.
- HydroQuebec. (2021). Retrieved from <https://news.hydroquebec.com/en/press-releases/1781/champlain-hudson-power-express-finalizes-contract-to-deliver-clean-energy-to-new-york-city/>
- Klein, K., Herkel, S., Henning, H.-M., & Felsmann, C. (2017). Load shifting using the heating and cooling system of an office building: Quantitative potential evaluation for different flexibility and storage options. *Applied energy*, 203, 917-937.
- Lee, K.-H., Joo, M.-C., & Baek, N.-C. (2015). Experimental evaluation of simple thermal storage control strategies in low-energy solar houses to reduce electricity consumption during grid on-peak periods. *Energies*, 8(9), 9344-9364.
- Morovat, N., Athienitis, A. K., Candanedo, J. A., & Dermardiros, V. (2019). Simulation and performance analysis of an active PCM-heat exchanger intended for building operation optimization. *Energy and Buildings*, 199, 47-61.
- Mulville, M., Jones, K., & Huebner, G. (2014). The potential for energy reduction in UK commercial offices through effective management and behaviour change. *Architectural Engineering and Design Management*, 10(1-2), 79-90.
- NRCan. (2021). CanMETEO. Retrieved from <https://www.nrcan.gc.ca/energy/canmeteo/19908>
- O'Brien, W., & Athienitis, A. (2015). *Modeling, design, and optimization of net-zero energy buildings*: John Wiley & Sons.
- Ouf, M. M., & Issa, M. H. (2017). Energy consumption analysis of school buildings in Manitoba, Canada. *International Journal of Sustainable Built Environment*, 6(2), 359-371.
- Ruusuu, R., Cao, S., Delgado, B. M., & Hasan, A. (2019). Direct quantification of multiple-source energy flexibility in a residential building using a new model predictive high-level controller. *Energy Conversion and Management*, 180, 1109-1128.
- Statistic Canada. (2017). Elementary–Secondary Education Survey for Canada, the provinces and territories. . Retrieved from <https://www150.statcan.gc.ca/n1/daily/quotidien/171103/dq171103c-eng.htm>.

ACKNOWLEDGEMENT

Technical support from Hydro-Québec Laboratoire des Technologies de l'énergie Shawinigan research center under NSERC/Hydro-Quebec Industrial Research Chair is greatly acknowledged. Also, technical support provided by Commission scolaire de la Seigneurie-des-Mille-Îles (CSSMI) is acknowledged with thanks. The authors would like to thank NSERC for the funding of this project through Dr. Candanedo's Discovery Grant, and the NSERC/Hydro-Québec Industrial Research Chair ("Optimized operation and energy efficiency: towards high performance buildings") held by Dr. Athienitis. The comments of our colleagues at CanmetENERGY are gratefully appreciated.