

# Graphical Abstract

## Coordination of Specialised Energy Aggregators for Balancing Service Provision

Cesar Diaz-Londono, Carlos Adrian Correa-Florez, José Vuelvas, Andrea Mazza, Fredy Ruiz, Gianfranco Chicco

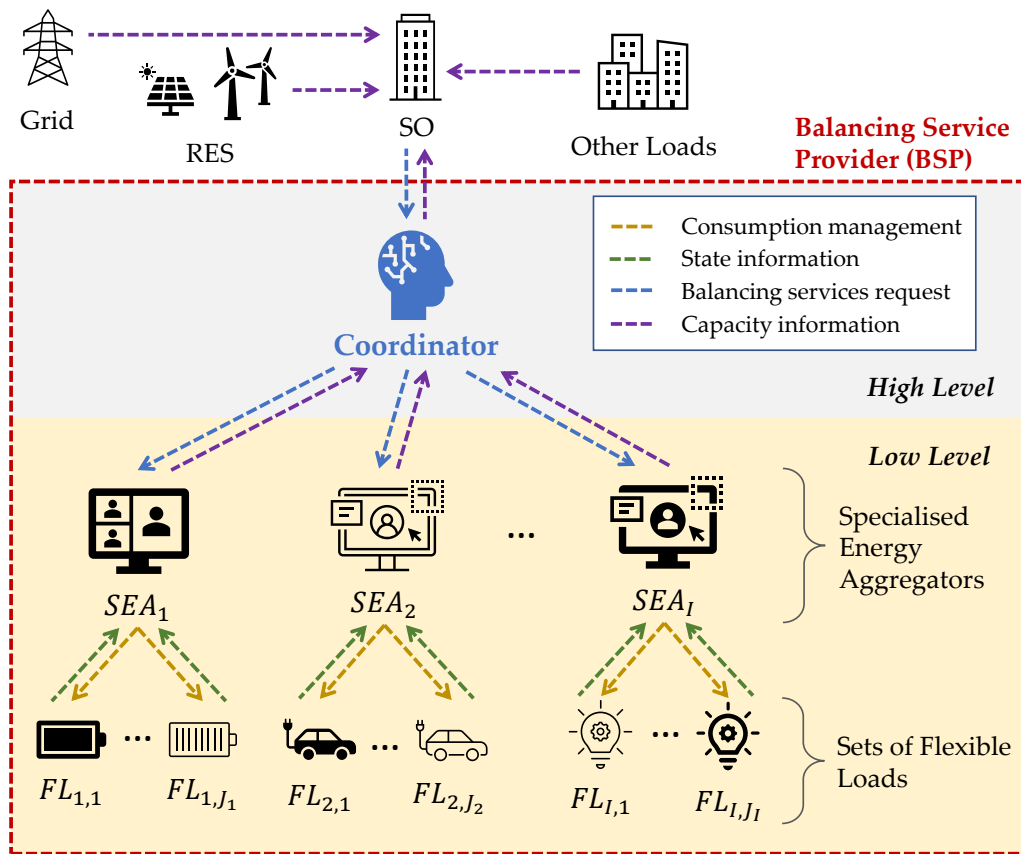

## Highlights

### **Coordination of Specialised Energy Aggregators for Balancing Service Provision**

Cesar Diaz-Londono, Carlos Adrian Correa-Florez, José Vuelvas, Andrea Mazza, Fredy Ruiz, Gianfranco Chicco

- Specialised Energy Aggregators (SEAs) are proposed for different types of loads.
- The SEAs interact with a Coordinator for providing balancing services.
- The information exchange between the Coordinator and the other entities is defined.
- The control algorithm developed for the Coordinator is described.
- The multiple SEA effectiveness to provide coordinated balancing services is assessed.

# Coordination of Specialised Energy Aggregators for Balancing Service Provision

Cesar Diaz-Londono<sup>a,b,c</sup>, Carlos Adrian Correa-Florez<sup>b</sup>, José Vuelvas<sup>b</sup>,  
Andrea Mazza<sup>c</sup>, Fredy Ruiz<sup>a</sup>, Gianfranco Chicco<sup>c</sup>

<sup>a</sup>*Dipartimento di Elettronica, Informazione e Bioingegneria, Politecnico di Milano, Milan, Italy*

<sup>b</sup>*Departamento de Electrónica, Pontificia Universidad Javeriana, Bogota, Colombia*

<sup>c</sup>*Dipartimento Energia “Galileo Ferraris”, Politecnico di Torino, Turin, Italy*

---

## Abstract

In the present context of evolution of the power and energy systems, more flexibility is required on the generation and demand side, to cope with the increasing uncertainty mostly introduced by variable renewable energy resources. This paper presents a conceptual framework that encompasses different types of aggregators, including local network aggregators, demand-side general aggregators, specialised energy aggregators (SEAs), and energy community aggregators. In this framework, this paper focuses on the coordination of SEAs to provide balancing services to the system operator. Each SEA manages a specific type of load, in such a way that these loads can be managed by exploiting their control capabilities in a detailed way considering response time, dynamics and available flexibility. Moreover, the presence of the SEAs increases the privacy protection of the users, as only the information on a specific type of user’s load is sent to the SEA. The SEA Coordinator interacts with the Balancing Service Provider aimed at procuring frequency containment, frequency restoration and replacement reserve services. This paper contains the SEA Coordinator formulation, information exchange and control operation strategies. Case study applications are presented by using SEAs for three specific types of loads (thermoelectric refrigerator, water booster pressure systems and electric vehicle charging stations). The results show how the control algorithm of the SEA Coordinator is effective in providing balancing services at different timings with the different types of loads. Various scenarios are considered, comparing an ideal situation without command propagation delays with realistic situations that take into account the

command propagation delays.

*Keywords:* Aggregator, balancing service, electric vehicle charger, flexibility, frequency containment, frequency restoration, reserve, smart grid, thermoelectric refrigerator, water booster pressure system.

---

## 1. Introduction

Power and energy system flexibility is one of the most debated topics in today's research. In general terms, the flexibility of the power and energy system concerns the system *operation*. Different definitions and characterisations of flexibility from a technical point of view have been given on the generation side, the grid side, and the demand side [1]. In a context with resources and reserves, operational flexibility is defined as the "Technical ability of a power system unit to modulate electrical power feed-in to the grid and/or power out-feed from the grid over time" [2]. Specific indicators are based on maximum capacity, minimum stable generation and up/down ramp rates of conventional generators [3], determining the aggregated maximum flexibility through Minkowski sums on polytopes [2]. In addition, the available operational flexibility depends on time-variable constraints [4].

On the generation side, many approaches used to represent flexibility are inspired by unit commitment and economic dispatch [5], using appropriate approaches to incorporate uncertainty [6].

On the grid side, flexibility considers the ability of the power system to use flexible resources to cope with fluctuating changes during operation, which could increase the risk of congestion [7].

On the demand side, flexibility can be obtained by using an aggregation of components capable to adapt their consumption over time, also considering local production in case of prosumers. The various components of the demand side have been the subject of specific studies for determining their potential for flexibility. Specific results have been reported for aggregate loads with thermostatic control [8] also represented with a virtual battery model [9], water booster pressure systems [10], building space heating [11], multi-energy systems [12], energy conversion technologies [13], electric vehicles [14], aggregation of residential loads [15], and the contribution of buildings to energy flexibility [16]. Virtual battery models have emerged as interesting tools for representing different situations [17]. The examples reported above highlight

the main concepts and issues, while a comprehensive review of the literature is beyond the scope of this paper.

Further considerations have been introduced for the characterisation of flexibility on the economic side. In this case, relevant aspects are the introduction of flexibility products and contracts [18], the emergence of concepts linked to the representation of the average power patterns for determining new contract structures [19], and the definition of economic and commercial flexibility through the mapping of iso-cost regions [4].

### *1.1. The Role of the Aggregators*

Starting from the characterisation of the technical and economic features related to flexibility, a significant aspect is the deployment of the resources in energy markets based on price signals or incentives to participate in the provisioning of system services through flexibility. This can occur in the context of demand response (DR) programmes, which offer the opportunity to exploit the flexibility potential of small end-users by modifying their consumption. DR programmes can be classified into two categories: incentive-based programmes and price-based programmes [20]. In this respect, groups of users can be conveniently represented by an *aggregator* that manages a portfolio of end-users and interacts with the DR manager [21].

The presence of the aggregator has multiple advantages. For example, small end-users may be unable to implement and manage the infrastructure needed to access DR options and, in general, have no specific knowledge on the market mechanisms involved in the provision of DR. Hence, the aggregator acts as an intermediate operator that avoids sending private information on the individual end users to the DR manager, in particular on costs [22]. Moreover, the aggregator benefits from managing a group of end-users which can together offer a smoother average power curve. In the DR programmes, the aggregator can offer specific ancillary services [23] in the balancing market such as upward or downward flexibility over day-ahead or intra-day time horizons, to provide these services in real time. In this framework, there is room for the development of local flexibility markets [24].

Most strategies for controlling aggregators focus on price-based programmes, in which the offered flexibility capacity depends on the price signal defined by an overall managing entity such as the Distribution System Operator (DSO) [25]. The DSO aims at achieving the optimal scheduling of the power consumption or production of the individual aggregators by determining the energy and ancillary service prices [26]. Each aggregator determines how to

operate the controlled assets in response to the price signal, adopting local coordinating mechanisms in a strategic way [27], or game-theoretical models [28]. Each aggregator acts as a price taker with respect to the wholesale market, and as a price designer for billing the aggregate assets [29].

On the other hand, in incentive-based programmes the aggregators are coordinated by the DSO, typically under the objective of minimising the energy losses and costs in the network, while the local aggregators minimise their own energy consumption cost or maximise their profits. In this kind of models, the optimisation problems of the DSO and of the local aggregators are solved independently, for example considering battery energy storage as the flexible asset [30], or controlling clusters of residential assets (thermostatically-controlled loads, electric vehicles, and water booster pressure systems) with an aggregator that provides energy regulation services at hourly intervals. After the determination of the strategy for controlling the assets, the aggregator can report to the DSO the optimal power profile [31] or some load boundaries only [32].

### *1.2. Coordinated Management of Multiple Aggregators*

In the presence of multiple aggregators, a coordination is needed. In this case, multi-layer aggregation schemes can be defined, in which each entity on a given layer interacts with the entities located in the layer at the lower level, and there is an overall coordinator that has no direct access to the final users. The development of multi-layer schemes needs the creation of dedicated aggregators that act as interfaces between the “master” operator (e.g., the distribution network operator, DNO) and the users. One of the main advantages of the development of dedicated aggregators is privacy protection, such that the “master” operator has no access to information on the users managed by the dedicated aggregators [25]. The dedicated aggregators connected to the “master” operator (or more generally to a higher-level aggregator) can be set up considering different prospects, as:

1. Local network aggregators (LNAs): needed to consider the operational constraints of the local network and to construct a portfolio of different types of generation or demand [33]. An example is a virtual power plant [34] considered as the “master” operator with multiple distributed energy resource aggregators. The aggregation can include local energy systems that are aggregated individually [35] or interact under the coordination of a multi-energy player that acts as the “master” operator [36].

2. Demand-side general aggregators (DGAs): manage different types of demand without considering the grid operation. Typical examples are aggregators that interact with the DNO and coordinate demand response in a low voltage network [37] or demand-side flexible resources [38]. Multiple load aggregators can be coordinated to provide frequency regulation services [39].
3. Specialised energy aggregators (SEAs): exploit the specific knowledge on different types of assets (generation or demand), to provide effective interactions with each type of asset, and using dedicated communication channels (specific information timing) for each set of resources. Each SEA is dedicated to a specific type of asset and is able to apply strategies (e.g., generation curtailment, load shedding, or flexibility services) selectively to the given asset [40]. Distinct SEAs can be defined for dispatchable distributed generation, renewable energy with storage [41], various types of equipment used for DR [42] including consumer responsiveness [43], electric vehicles [44] and charging stations [45]. Each SEA can handle the specific asset by considering more details in the models and control strategies [46], avoiding the need of designing overall strategies for many assets together.
4. Energy community aggregators (ECAs): energy communities do not necessarily include a local network. The ECA can be seen as an aggregator of multiple sources (generation and demand) of various kinds, located at different points in the network, or moving in the community such as electric buses [47]. The ECAs consider self-consumption and self-sufficiency of the energy community, as well as synergies between a building manager and an aggregator of electric vehicles to solve a scheduling problem in a coordinated way [48]. The aggregation of energy communities is a timely topic that needs to find appropriate business models [49].

Each DGA or SEA does not carry out network modelling, network monitoring, or assessment of the network operation. These tasks are assigned to the “master” operator (higher-level aggregator or coordinator).

### *1.3. Behaviour of Aggregators in Markets*

The introduction of distributed energy resources has prompted the emergence of new actors and policies in the electrical market. A stochastic optimisation problem is designed as a strategy of an aggregator that participates

in the day-ahead market with demand flexibility in [50, 51]. For aggregator operation, a network-constrained transactive energy paradigm is proposed to integrate prosumers with the spot and balancing markets in [52].

Further approaches consider the aggregator as a price-maker in the wholesale electricity market and use a bilevel programming model of the interaction between the aggregator and the independent system operator that manages the market. In this case, the upper-level problem represents the cost minimisation [53] or profit maximisation of the aggregator of a microgrid [54] or virtual power plant [55], and the lower-level problem represents the market clearing problem of the independent system operator.

Moreover, in [56], a bi-level optimisation technique is used to design the involvement of a renewable energy-based aggregator in a real-time market. Furthermore, Nash bargaining theory is used in [57] to create an aggregator and a price scheme that clusters small energy storage devices, demonstrating long-term cooperation between players and avoiding market power abuse by an aggregator that plays in the wholesale market. Owing to the aggregator's function in the day-ahead market and its price volatility, a mechanism design is created in [58] to limit the aggregator's risk of financial loss due to spot price unpredictability. Furthermore, an optimal portfolio allocation for a demand response aggregator is provided in [59], considering its participation in day-ahead electricity prices and load contract types. The incorporation of aggregators into the electricity markets is still a hot topic of debate.

#### *1.4. Contributions and Organisation*

None of the above-mentioned models that deal with the coordination of aggregators consider the provision of many ancillary services from specialised aggregators. An initial conceptual framework for the coordinator of aggregators with heterogeneous flexible loads has been outlined in [60]. Flexible loads are considered with both continuous and discrete models. Each aggregator is specialised for a given type of flexible load, and uses predictive-optimal controllers and classical Proportional-Integral (PI) controllers to manage the loads flexibility.

According to ENTSO-E [61], a Balancing Service Provider (BSP) is an agent (e.g., generator, demand response and storage operator) that can offer balancing services to the System Operator (SO). In this paper, an entity, denoted as Coordinator, interacts with the BSP and is responsible of providing flexibility services for the coordination of the distributed flexible loads aggregated by the Specialised Aggregators. In particular, Water Booster Pressure



Systems (WBPS), ThermoElectric Refrigeration (TER) units, and Electric Vehicle Charging Stations (EVCS) are considered as flexible loads in this paper. These types of flexible loads have the potential to provide various balancing services in the context of smart grids.

This paper is the extension of [60], with the following additional novelties:

- a) The categorisation of the energy aggregators presented in Section 1.2.
- b) The formulation of the SEA Coordinator with the development of the operation functions for planning and tuning the SEAs power demand.
- c) The definition of the main parameters for information exchange between the SEA Coordinator and the SO as well as between the SEA Coordinator and the SEAs.
- d) The development of the control algorithm used by the SEA Coordinator to follow the SO requests, taking into account the previously constructed power baseline.
- e) The extension of the case study application, including the propagation delay of the commands and the possibility of offering higher capacity for the reserve service thanks to an improved management of the interactions among multiple SEAs in the longer term.

In the proposed framework the task of the Coordinator is to manage the aggregated services based on purely technical considerations, without economic considerations, i.e., no market participation [24] or price formation model is assessed. Instead, it is considered that prices are defined a priori through bilateral contracts between the BSP and the aggregators, and also between the aggregators and the customers.

The next sections of the paper are organised as follows. Section 2 recalls the characteristics of the balancing energy services used to maintain or restore the system frequency within its normal operating range. Section 3 describes the hierarchical coordination of a set of specialised aggregators. Section 4 evaluates the BSP operation based on simulation campaigns. Section 5 contains the conclusions and points out some notes on future works.

## 2. Provision of Balancing Services

In the past, the power systems exhibited as the main uncertainty source the variability of the loads. Hence, the continuous equilibrium between loads

and generation was guaranteed through successive power injections or reductions by acting on the generation control system, which led to modify the power produced by every generator. Today, new forms of frequency support are required, because the uncertainty is affecting also the generation, due to the variability of the energy sources. The challenge of maintaining the system stability has to be faced by all the system operators, that hence must rely on common definitions and markets. With this aim, the European Commission Regulation 2017/1485 of 2 August 2017 [62] introduced the different products that can be offered for frequency regulation, as well as the requirements for the technical parameters to facilitate the exchange of balancing energy across borders.

The standard products offered on the balancing service market are the following:

- Frequency Containment Reserves (FCR) [62]: this reserve aims intervening after the unbalance to contain the frequency and start the recovery towards the nominal frequency value;
- Frequency Restoration Reserves (FRR) that can be activated automatically (aFRR) [63] or manually (mFRR) [64]: the role of this reserve is to provide the active power resources to restore the frequency at its nominal value.
- Replacement Reserves (RR), aiming to restore the proper level of FRR, in a way that the reserves can be able to face further imbalance.

Table 1 presents the full activation time and delivery periods of the balancing energy services.

Table 1: Balancing energy services [62, 63, 64, 65].

<b>Service</b>	<b>Full activation time</b>	<b>Delivery Period</b>
FCR	15 s (50%) - 30 s (100%)	15 min
aFRR	5 min	15 min
mFRR	12.5 min	15 min
RR	0 - 30 min	15 min - 60 min

Figure 1 shows a schematic representation of the timing of the intervention and deployment of every frequency reserve after a power imbalance

happening at the time step  $t_0$ . Within 30 s the FCR of the system must be entirely deployed, followed by the aFRR (completely active within 5 minutes), which allows the restoration of both the FCR reserve (which results again available to face possible successive power imbalance) and the nominal value of the frequency. Then, the mFRR substitutes the aFRR (that is then released to face further imbalance), being completely deployed after 12.5 minutes. Finally, the RR activation is performed after 30 minutes, to release the mFRR and bring the system to a new operation point, after having adjusted the set points of the traditional generation.

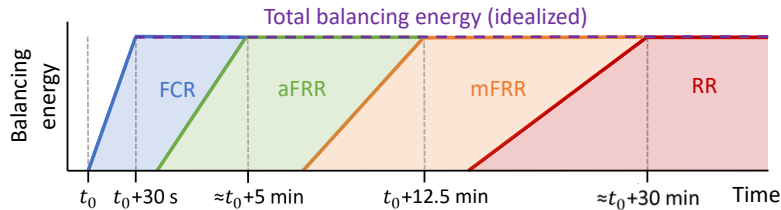

Figure 1: Balancing processes for frequency restoration.

Moreover, the European Commission Regulation 2017/2195 of 23 November 2017 [66] introduced common principles for both the procurement and the settlement of the reserve products among the different European countries. This led to create pilot platforms to test the provision of the products among the partners, i.e. [67]:

- FCR platform [68], involving up to now eight European Transmission System Operators.
- Platform for the International Coordination of Automated Frequency Restoration and Stable System Operation (PICASSO) [69], which is the European platform for the exchange of balancing energy from aFRR. It counts 26 members and four observers;
- Manually Activated Reserves Initiative (MARI) [70], aiming to build a common market platform for the mFRR deployment. It counts 30 members and four observers;
- Trans European Replacement Reserves Exchange (TERRE) [71], representing the RR Platform where the European RR balancing energy market is set up. It counts 8 members and four observers.

Besides the standardisation of the frequency reserve products, the innovations included within the European framework continued thanks to the *Electricity Regulation* 2019/943 [72] and the *Electricity Directive* 2019/944 [73], issued as part of the *Clean Energy for all the Europeans* package [74]. Here, the role of the customers and of the aggregators is stressed as fundamental for the proper operation of the system. In particular, the Electricity Regulation 2019/943 improved the possibility of participation in the ancillary service market (where the frequency reserve products are actually exchanged) for aggregation of distributed resources. Two different players are defined, i.e.:

- the Balancing Service Provider (BSP)
- the Balancing Responsible party (BRP)

The BSP is the entity that presents the offers/bids on the market, as an aggregator of distributed energy facilities. Once the offer/bid is accepted, this must be handled by the distributed resources owners/managers, i.e., the BRP. It is worth noting that the contractual relation between BSP and BRP are not specified by the regulation and hence is open to the discussion about the two entities.

The operation of the BSP, with the contribution of the Coordinator, is driven by the SO for ensuring the balance between demand and generation in the real-time dispatch, by activating the flexibility services. The balancing market normally considers the SO, the BSP, and the BRP, and consists of two phases:

1. *Balancing planning phase*: performed in a day-ahead market. The BRP reports the scheduled demand and generation per time step, computes the energy imbalances and sends them to the SO. The BSP informs the SO about the power demand baseline, defined as the sum of all the aggregator power demand. This can be based on forecast or historical data. The BSP offers to the SO upward and downward flexibility capacities, based on the sum of all the aggregator flexibility. Each aggregator is responsible for its own flexibility forecast and baseline.
2. *Balance settlement phase*: performed in real-time market. The SO guides the BSP for activating the balancing service based on the BRP imbalances information. The coordination within the BSP allocates the SO energy request among the aggregators. Each aggregator manages its loads and generation resources providing upward or downward power variations to follow the coordination requests.

### 3. Hierarchical Structure for a Balancing Service Provider

In this section, a hierarchical structure for a BSP is proposed, considering a two-level structure. Figure 2 presents the BSP structure taking into account:

- i) the Coordinator at the higher level, and
- ii) several Specialised Energy Aggregator (SEAs) at the lower level.

The existence of the Coordinator within the BSP allows to obtain reduced communication requirements between the BSP and the SO. In the same way, the internal interaction between the higher level and lower level layers considers a few parameters. In fact, the information is limited to the power and flexibility capacities, and the balancing services requests (FRC, FRR, and RR). In other words, the communication protocol between the higher level and lower level participants is independent of the type of load being managed.

Each SEA is responsible for managing the energy consumption of a heterogeneous set of flexible loads of the same load type, e.g., a set of electric vehicles with different battery capacities and charging power, among others. Therefore, the challenge of the Coordinator consists of integrating several SEAs that operate with different parameters such as load characteristics and response times. In fact, the Coordinator is given the responsibility of controlling the aggregators, as well as to proper communication exchange with the SO. The presence of the SEAs increases the privacy protection of the users. In fact, each user sends to each SEA only the information on the relevant type of user's load. The Coordinator, at the top of the BSP, interacts with the SO by sending information on the aggregate demand of the types of load managed. No entity manages the overall demand of the user for providing the balancing services.

The higher-level communication protocol is decoupled with respect to the one of the flexible loads. Indeed, each SEA operates its loads based on its own rules. In this research, a simplified exchange of information between each aggregator and its flexible loads is presented. It considers the power demand profiles the loads should follow (Consumption management), and the actual power and flexibility load states.

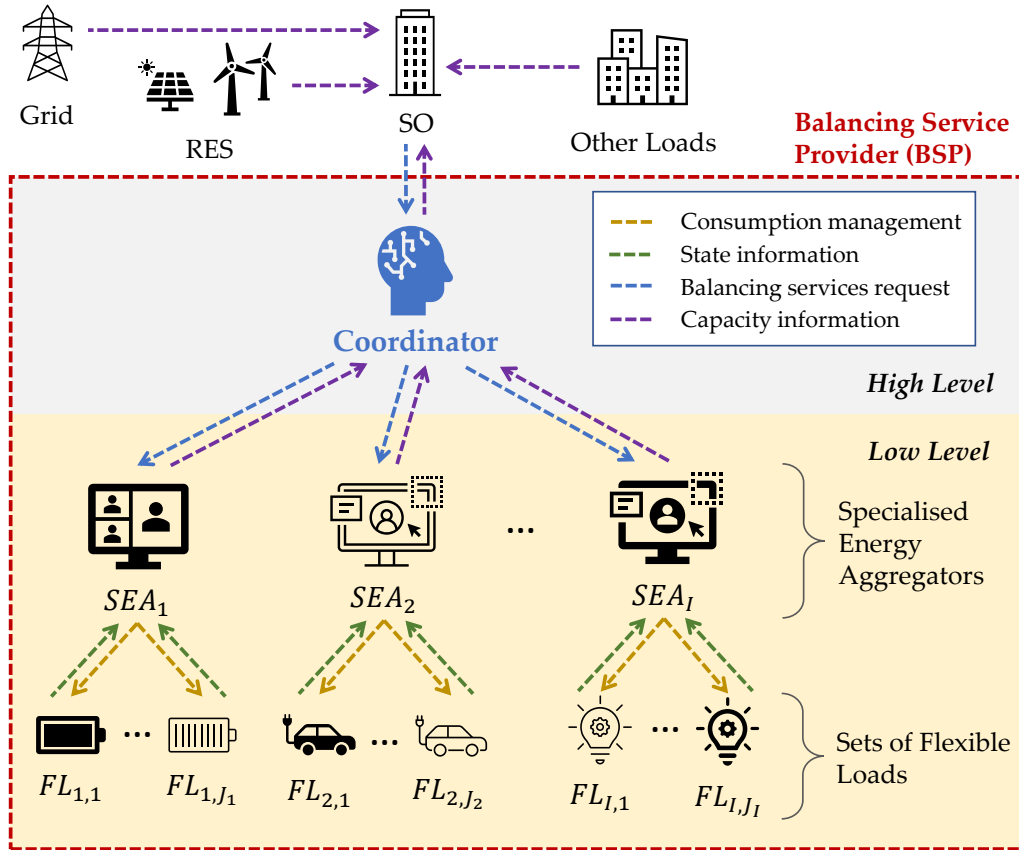

Figure 2: Two-level BSP general structure.

The BSP is capable of offering a portfolio of balancing energy services based on the aggregators' capacity. Then, the higher-level entity (i.e., the Coordinator) is responsible for collecting the power demand and flexibility of the aggregators, for later computing the power baseline schedule. Usually, this baseline schedule is developed on an hourly time-based horizon, whereas the dispatch could be performed on a 15 minutes or less time base. Therefore, the Coordinator can operate on different time bases.

At the lower level, a generic behaviour of the SEA is assumed. It means that the SEA must be capable to provide flexibility as well as following power demand variations with an expected response time. The aggregators must be available to calculate and report their actual power demand and flexibility capacity periodically to the Coordinator. In addition, SEAs can be based on closed-loop control strategies that allow to reduce the uncertainty in the

service provision.

The two-level hierarchical structure is scalable by varying number and characteristics of the SEAs. Better performance of the balancing service can be reached if more SEAs participate in the framework.

### 3.1. Coordinator of Specialised Energy Aggregators

The Coordinator is developed by considering the SO requirements and the availability of flexible resources provided by each SEA, in order to procure balance services such as FCR, aFRR, mFRR, and RR. Then, the main responsibilities of the Coordinator are:

- Understand the capacity and response time of each SEA.
- Offer a portfolio of balancing energy services based on the complete flexibility of the structure to the SO.
- Assign the balancing services that each SEA can provide.
- Manage the SO requests, i.e., if some SEA has variations while following its requested power, the Coordinator can compensate the overall power by activating/modifying other SEAs requests.

The Coordinator considers a baseline calculation and a two-phase operation, with a *Planning phase* and a *Tuning phase*. The decision of the service provision starts with the baseline computation, i.e., the power demand and the flexibility capacity for a time horizon. This baseline is built upon the information provided by each aggregator. Then, the coordinator evaluates and calculates the services to offer to the SO.

The *Planning phase* aims to schedule the SEA energy consumption for the next dispatch time interval (e.g., 15 min). Therefore, this planning seeks not only to follow the power demand baseline but also to guide the aggregators' power dispatch in providing balancing services. The Coordinator will request a power baseline modification to many aggregators as needed to fulfil the SO request. The aggregators' selection criteria are the availability and the flexibility capacity reported by each aggregator. Notice that this phase is developed for every dispatch time interval and it will depend on the SO requests.

The *Tuning phase* aims to correct the unexpected SEA consumption variations due to the uncertainties in the flexible loads behaviour. In order to

compensate these variations, the Coordinator operates on a smaller time interval than in the planning phase. Therefore, the Coordinator will request a slight modification from the power defined in the planning phase to some of the aggregators that have reached their steady-state operation and have flexibility margins available.

### 3.2. Coordinator Formulation

In this subsection, the Coordinator formulation is introduced by presenting its interactions and the algorithm logic that the Coordinator follows in the operation (planning and tuning) to define the SEA requested powers.

Given the BSP general structure presented in Figure 2, let us assume that there are  $I$  aggregators, whose power demand profiles are programmed through the Coordinator. Then, each aggregator  $SEA_i$  can be called or not to provide its flexibility, i.e., to modify its current power consumption profile for a defined period of time.

Figure 3 depicts the response of different aggregators to the Coordinator request. The figure shows the activation time, the delivery period, and the ramp-down period of the balancing service requested by the SO. In this example case, it is supposed that for fulfilling the entire SO request, only the  $SEA_1$ ,  $SEA_2$ ,  $SEA_{I-1}$ , and  $SEA_I$  are called to modify its power demand. Notice that, the response times and the sample time (grey vertical rows) of the aggregators are different between them. In the figure, the blue lines on the  $SEA_i$  are the power modifications requested (signal to follow) by the Coordinator in the planning phase, while the red dashed lines are the expected power demands on the same phase. In addition, the yellow dots are the actual power demands after operating the tuning phase. The orange vertical arrows indicate the time steps for running the planning phase, whereas the green vertical arrows mark the time steps for executing the tuning phase.

The Coordinator operation time in the planning phase is divided into  $K_P$  discrete time intervals with equal length, being a discrete time slot  $k_P = 1, 2, \dots, K_P$ , with sampling time  $\Delta t_P$  defined as the BSP dispatch time. Therefore, at every  $k_P$  the Coordinator recalculates the aggregators schedule and possibly defines new set-points. The Coordinator operation time slot in the tuning phase is defined as  $k_T = 1, 2, \dots, K_T$ , with sampling time  $\Delta t_T$ , where  $\Delta t_P > \Delta t_T$ .

The tuning phase sampling time  $\Delta t_T$  depends on the aggregators that have *very short duration* time response, according to [75], i.e., aggregators capable to respond between seconds and 5 minutes, capable to provide FCR



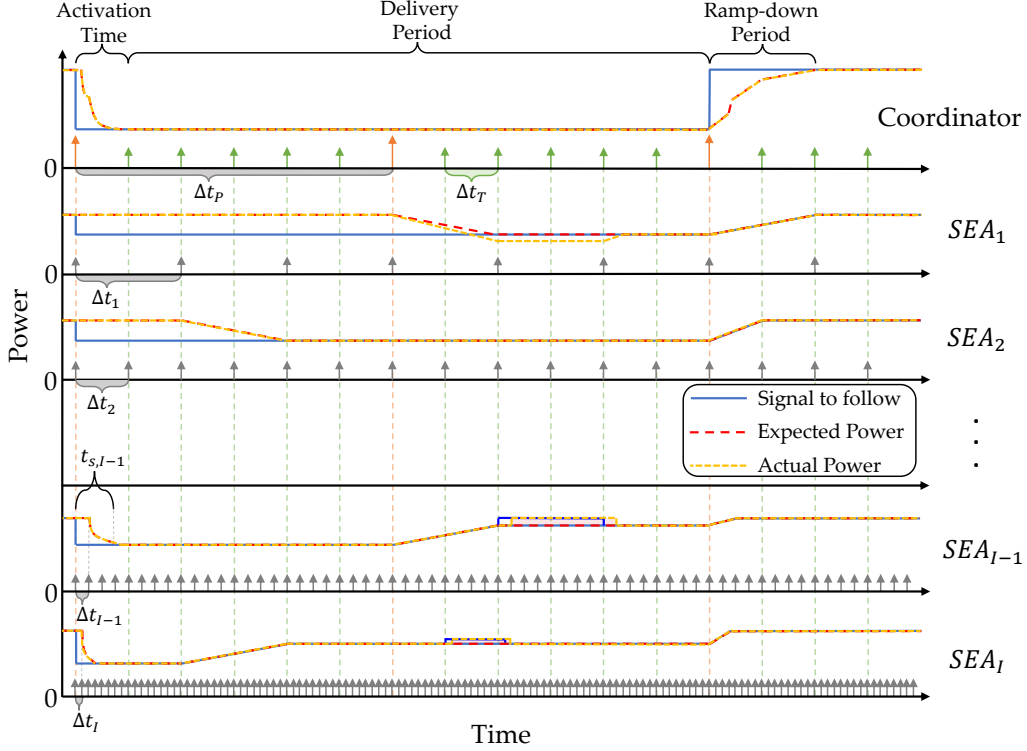

Figure 3: Specialised Energy Aggregators responding to the Coordinator requests.

and aFRR services. Then, within this set of aggregators, the important parameter to identify is the longest stabilisation time, which is not computed by the Coordinator but reported by each aggregator. This stabilisation time provides the minimum possible  $\Delta t_T$  time to have the opportunity to operate the aggregators already in a steady-state. In Figure 3, the available aggregators for providing fast services are  $SEA_{I-1}$  and  $SEA_I$  in which the longer stabilisation time is  $t_{s,I-1}$ . Therefore, in this example, the tuning sample time is  $\Delta t_T > t_{s,I-1}$ . For the sake of simplicity,  $\Delta t_T$  is considered as the nearest  $\Delta t_i$  of the aggregators.

Therefore, the general operation of the Coordinator will consider a time slot with sample time  $\Delta t_T$ . However, the tuning phase is not considered when the planning phase is executed.

Moreover, the  $SEA_i$  operation is divided into  $K_i$  discrete time intervals with equal length. The  $SEA_i$  time slot is  $k_i = 1, 2, \dots, K_i$ , with sampling time  $\Delta t_i, \forall i = 1, 2, \dots, I$ . Then,  $\Delta t_P > \Delta t_i$ .

### 3.2.1. Information Exchange

The Coordinator interaction is carried out with two main stakeholders, the SO and the SEAs (see Figure 2). The exchanged information is summarised as follows:

- Coordinator exchanged information with the system operator:

- From SO to Coordinator:

$$\Gamma_C = \{\vartheta_C, \overline{\gamma_C}, \underline{\gamma_C}, r_C\} \quad (1)$$

- From Coordinator to SO:

$$\Phi_C = \{P_C, \phi_C\} \quad (2)$$

- Coordinator exchanged information with the aggregators:

- From Coordinator to  $SEA_i$ ,  $\forall i = 1, 2, \dots, I$ :

$$\Gamma_i = \begin{cases} \{\vartheta_i, \overline{\gamma_i}, \underline{\gamma_i}, r_i\} & \text{if Planning phase,} \\ \{r_i \pm \Delta r_i\} & \text{if Tuning phase;} \end{cases} \quad (3)$$

- From the  $SEA_i$ ,  $\forall i = 1, 2, \dots, I$  to the Coordinator:

$$\Phi_i = \{P_i, \phi_i\} \quad (4)$$

where  $\Gamma$  is the energy request from an upper level, this could be from the SO ( $\Gamma_C$ ) or the Coordinator ( $\Gamma_i$ ). The request considers the balancing energy service type (i.e., FCR, aFRR, mFRR, or RR) in the variables  $\vartheta_C$  and  $\vartheta_i$ , the service starting time  $\overline{\gamma_C}$  and  $\overline{\gamma_i}$ , the ending service time  $\underline{\gamma_C}$  and  $\underline{\gamma_i}$ , and the power capacity to shift  $r_C$  and  $r_i$ . However, this request  $\Gamma_i$  from the Coordinator is considered in the Planning phase, while in the Tuning phase, only  $r_i \pm \Delta r_i$  is taken into account, where  $\Delta r_i$  is a fine tuning value. The Coordinator divides the request  $r_C$  into the  $i$  aggregators, and fulfils:

$$r_C = \sum_{i=1}^I r_i. \quad (5)$$

Moreover,  $\Phi$  reports the capacity, this could be  $\Phi_C$  from the Coordinator or  $\Phi_i$  the aggregators  $i = 1, 2, \dots, I$ . The reported values are the actual power  $P_C$  and  $P_i$ , and the flexibility capacity  $\phi_C$  and  $\phi_i$ . The Coordinator computes the net power  $P_C$  and the flexibility  $\phi_C$  as:

$$P_C = \sum_{i=1}^I P_i, \quad \text{and} \quad \phi_C = \sum_{i=1}^I \phi_i. \quad (6)$$

### 3.2.2. Control Algorithm

The Coordinator is developed by considering a feedback control sequence to follow the baseline power  $P_{Baseline}$ . When an increase or reduction request arrives at the BSP, the target to follow is modified from considering only the baseline power to considering the baseline and the SO request. This is performed in the planning phase, in which the Coordinator aims to minimise the power baseline-following error by considering the energy requests. Then, the Coordinator decides the energy service each SEA must provide (taking into account that all SEAs have different response times), by defining the power that each SEA should follow. To sum up, the Coordinator deals with the following optimisation problem in the planning phase:

$$P_i, \min_{i=1,2,\dots,I} \sum_{i=1}^I P_i - P_{Baseline} \pm r \quad (7a)$$

$$\text{s.t. } SEA_i \text{ Capacities} \quad (7b)$$

$$SEA_i \text{ Dynamics} \quad (7c)$$

$$\forall i = 1, 2, \dots, I \quad (7d)$$

The solution to the previous problem is the power  $P_i$  that each SEA should follow. Notice that these solutions are always feasible under the capacity information reported at the planning phase.

To summarise the Coordinator operation in both phases, the logic presented in Algorithm 1 is proposed. The first step of the algorithm is to identify the set  $L$  of aggregators able to provide fast services and acquire their stabilisation times  $t_{s,i}$  for computing  $\Delta t_T$ . Then, the total number of time slots  $K_T$  in the tuning phase is calculated based on the operation horizon  $H$ . The feedback control strategy starts in Step 5. On the one side, in the planning phase (Step 6), the Coordinator solves the problem presented in Eq. (7). On the other hand, in the tuning phase (Step 11), the algorithm assesses if the power baseline-following error is higher than the acceptable tolerance  $D$  on each SEA. Then, when the error is higher, the algorithm searches between the SEAs already in steady-state the one with maximum flexibility to request a slight modification  $\Delta r_i$  of its current demand in order to supply the power deviations of  $SEA_i$ .

---

**Algorithm 1** Coordinator Logic

---

**Input:**  $P_{Baseline}, \Gamma_C, \Phi_i \forall i = 1, 2, \dots, I$ **Output:**  $\Phi_C, \Gamma_i \forall i = 1, 2, \dots, I$ 

```
1: Identify the set  $L = \{SEA_i \mid SEA_i \text{ with fast response}\}$ 
2: Acquire  $t_{s,i} \in L$ 
3:  $\Delta t_T > \max\{t_{s,i} \in L\}$ 
4:  $K_T = H/\Delta t_T$ 
5: for  $k_T \leftarrow 1$  to  $K_T$  do ▷ Coordinator loop
6:   if  $k_T$  is in Planning phase then
7:     Solve Problem in Eq. (7) ▷ Set-point re-computation
8:      $r_i \leftarrow P_i$ 
9:     return  $\Phi_C$ 
10:  else ▷ Tuning phase
11:    for  $i \leftarrow 1$  to  $I$  do
12:       $\Delta r_i = |r_i - P_i|$ 
13:      if  $\Delta r_i > D$  then
14:        Identify the  $SEA_m \in L$  in steady-state and with  $\max\{\phi\}$ 
15:         $P_m \leftarrow r_m + \Delta r_i$ 
16:      end if
17:    end for
18:    return  $\Gamma_i \forall i = 1, 2, \dots, I$ 
19:  end if
20: end for
```

---

#### 4. Unified Aggregation Framework: Case Study

In this section, a case study of a hierarchical structure for a BSP is presented, taking into account the Coordinator and three different SEAs with its flexible load models (see Figure 4). Later, simulation results of the BSP operation are presented.

##### 4.1. Specialised Energy Aggregator

The SEAs considered in the BSP low level are presented below. Three types of load with different characteristics and aggregation strategies are included for illustrative purposes. However, the framework can be applied to any other flexible load, provided that an automatic control strategy for power regulation is available and the response time of the closed-loop system fits into any of the services described in Section 2.

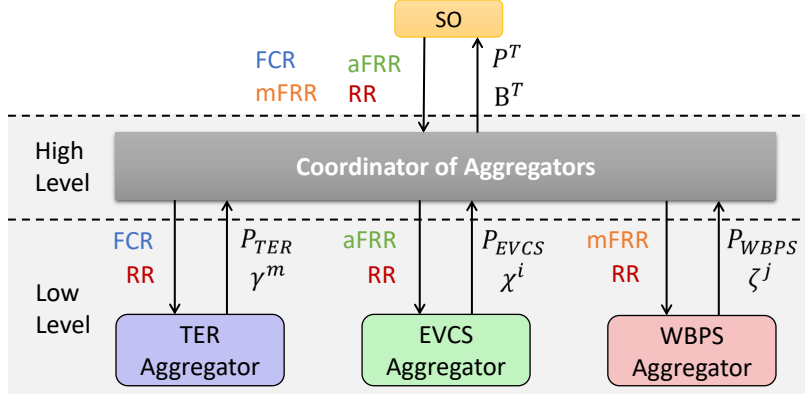

Figure 4: Two-level BSP structure: case study.

#### 4.1.1. ThermoElectric Refrigeration SEA

A ThermoElectric Refrigeration (TER) is a solid-state energy-conversion technology that exploits the Peltier effect to convert electricity into thermal energy for heating or cooling. Reference [76] proposes an aggregator for large populations of TERs, providing both upward and downward power deviations. The flexibility is achieved by changing the temperature set-point to the highest or lowest limit of each TER. The aggregated dynamic response is represented by linear transfer functions.

The aggregator (TER-SEA) is a proportional-integral (PI) feedback controller. The TER-SEA decides the amount of TER systems that must modify the temperature set-point  $\beta_{TER}$  (nominal, high, or low) based on the high-level coordination request  $r_{TER}$  and power consumption  $P_{TER}$  of the population. It is designed to avoid any rebound effect after providing any balancing service, leading to long recovery time; however, this is not desirable when coordinating several aggregators. Therefore, the TER-SEA controller is here improved for achieving faster changes when providing different services and interacting with many aggregators. This controller has the opportunity of changing the proportional and integral parameters for synchronising the power in few seconds when interacting with other SEA. In fact, due to the fast response of the TERs, instantaneous changes after the activation of a service can be considered. The interaction between TER-SEA and TER is depicted in the purple blocks of Figure 5.

#### 4.1.2. Water Booster Pressure Systems SEA

Water Booster Pressure Systems (WBPS) are responsible of supplying water and maintaining adequate pressure levels in a building pipeline. Reference [10] proposes an aggregator for large populations of WBPS, providing downward power deviations. The flexibility is achieved by changing the pressure set-point for each pressure tank. The aggregated dynamics are represented as a discrete time model with sampling time of 3 min.

The aggregator (WBPS-SEA) is a discrete-time PI controller with gain-scheduling. The WBPS-SEA offers downward flexibility by deciding the amount of WBPS whose pressure set-point must be modified ( $\beta_{WBPS}$ ), based on the high-level coordination request  $r_{WBPS}$  and current power consumption  $P_{WBPS}$ . The interaction between WBPS-SEA and WBPS is shown in the red blocks of Figure 5.

#### 4.1.3. Electric Vehicle Charging Station SEA

An Electric Vehicle Charging Station (EVCS) is composed of various chargers, to which electric vehicles (EVs) connect for being charged. Reference [77] proposes an aggregator to manage the charging profiles of the EVs served by the EVCS. The model considers a switching behaviour of the chargers, caused by the arrival and departure of EVs. The EV charger flexibility is defined as the maximum power deviations, given a nominal charging profile, that guarantee proper charge level at the end of the charging period.

The aggregator (EVCS-SEA) is based on a Model Predictive Control (MPC) strategy that aims following the aggregated power scheduled in the baseline and the Coordinator request  $r_{EVCS}$ , i.e., looking for minimising the baseline tracking error considering a penalty cost, subject to the charger state of charge dynamics ( $SoC_i$ ) and technical limits. The decision variables are the power delivered by each charger and the flexibility capacity. Moreover, the SEA has the capability to schedule a day-ahead power demand based on the expected EV chargers request. The baseline is formulated as an optimal control problem to minimise the operation cost while maximising the flexibility capacity, subject to battery dynamics and technical limits. This aggregator can provide upward and downward flexibility. The green blocks of Figure 5 show the interaction between EVCS-SEA and EVCS.

To summarise, Table 2 presents the main aggregators characteristics, considering response time, sampling time  $\Delta t$ , and upward and downward flexibility of each SEA. In fact, the TER-SEA and WBPS-SEA information is

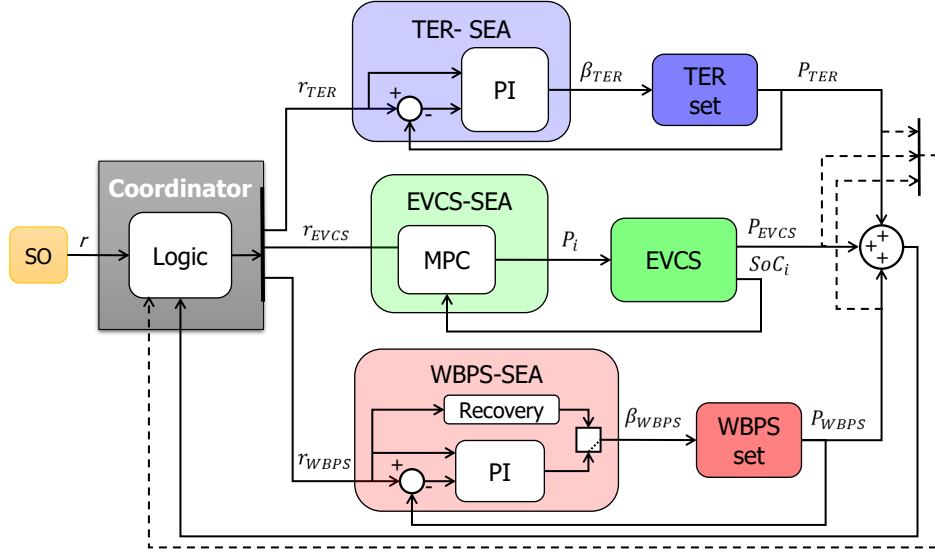

Figure 5: BSP operation scheme.

acquired from [76] and [10], respectively. In addition, according to [77] the EVCS-SEA response time is limited by few minutes, then, for sake of simplicity, a 3 minutes response time and a 1 minute  $\Delta t$  are defined.

Table 2: SEA main characteristics

SEA	Response time	$\Delta t$	Downward Flexibility	Upward Flexibility
TER-SEA	20 s	1 s	63% (FCR) or 53%	123% (FCR) or 85%
EVCS-SEA	3 min	1 min	Based on definition of reference [77]	
WBPS-SEA	9 min	3 min	27%	0

#### 4.2. Simulations of the Balancing Service Provider Operation

Simulation campaigns were performed to evaluate the capability to provide FCR, FRR, and RR services. The results compare the baseline power schedule with the actual power consumption considering the balancing services provision.

The SEA baseline power schedules are defined as: i) nominal power consumption for the TER-SEA and the WBPS-SEA, considering residential TERs and WBPS; and ii) the day-ahead scheduling for the EVCS, taking

into account a station with 25 chargers, each one capable of injecting 8 kW. More information related with the simulation parameters can be found in Table 3. In fact, the tuning phase operation sample time is  $\Delta t_T = 3$  min, i.e., the Coordinator operation sample time. This time is obtained by analysing the very short duration time response aggregators, in which the TER-SEA and EVCS-SEA are suitable (see Table 2). Then, being  $\Delta t_T \geq 1$  min and considering the WBPS-SEA sampling time, a 3 minutes sampling time is defined for the tuning phase. Moreover, the planning operation phase is defined as  $\Delta t_P = 15$  min, considering it as the dispatch time.

Table 3: Simulation parameters

<b>Parameter</b>	<b>Value</b>
Number of TERs	4000
Number of WBPS	1000
Number of EV chargers	25
$\Delta t_T$	3 min
$\Delta t_P$	15 min

Based on Table 2, the flexibility offered by each SEA is fixed as the capacity found by the proposers of the aggregators:

- TER-SEA: considering the flexibility for RR service, the upward and downward capacities are 85% and 53% of the baseline, respectively.
- WBPS-SEA: the downward flexibility capacity of 27% of the baseline is considered.
- EVCS-SEA: upward and downward flexibility capacities based on the chargers flexibility definition provided in [77] are considered.

Figure 6 presents the flexibility offered by each aggregator, as well as the aggregated capacity offered by the BSP to the SO. The total flexibility is always higher than  $\pm 100$  kW. However, the flexibility usage will depend on the service provision, e.g., with the purpose of providing all the balancing services in the same frequency restoration process, i.e., FCR, FRR, and RR, it is not possible to offer 100% of the capacity. In fact, only the TER-SEA can provide fast services such as FCR. Then, following the frequency restoration process presented in Figure 1, the maximum capacity is defined by the aggregator with the fastest response, i.e., TER-SEA. Moreover, for



long-lasting services such as mFRR and RR, the flexibility offered by the BSP can be the complete capacity depicted in Figure 6.

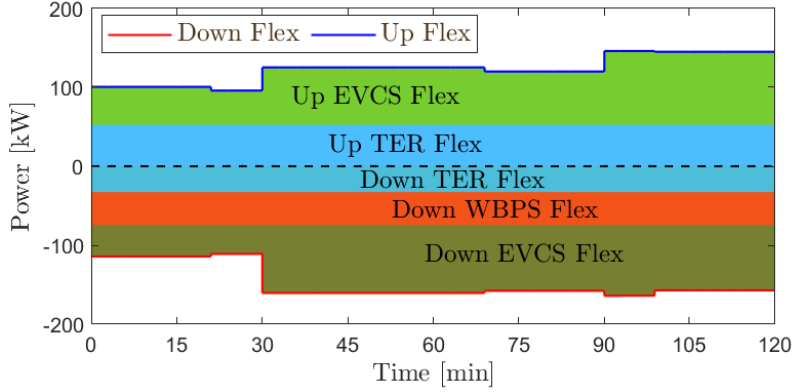

Figure 6: Flexibility of the BSP.

The BSP performance in a frequency restoration operation is evaluated for two different energy balancing service provisions:

- *Case 1*: Providing all the balancing services. Therefore, the maximum capacity provision is constrained by the TER-SEA (the one with a fast response). Moreover, this case follows an idealistic scenario because no command propagation delay is supposed, i.e., the information exchange between all the participants is instantaneous. Then, two approaches are evaluated:
  - *Case 1.a*: Each SEA provides a specific service every 15 minutes. Nevertheless, the RR service is provided by all the SEA.
  - *Case 1.b*: The services are provided by overlapping the SEA power requests, following an idealised provision case (see Figure 1).
- *Case 2*: Providing the mFRR and RR services. Then, the capacity provision is much higher than in *Case 1*. Moreover, this case follows a realistic scenario because the commands propagation delays are taken into account.

Both cases 1 and 2 are evaluated in MATLAB/Simulink simulations. These cases provide different power capacities due to the maximum power the TER (fast service) can provide to the grid in the *Case 1*, and the total

flexibility all the SEAs can provide in the *Case 2*. The Coordinator defines and reports to the SEAs the power deviation they should follow. Moreover, in the simulations, only reduction power requests by the SO are analysed due to the WBPS response that only considers flexibility reduction.

Figure 5 shows the two-level structure operation, with the two-level BSP. The TER and WBPS sets are represented by linear transfer functions. These functions allow the simulation to be computationally lightweight. Besides, the MPC and EV charger dynamics are run in MATLAB.

#### 4.2.1. Case 1.a

The case study evaluates a frequency restoration process where all the aggregators participate in providing balancing services in an idealistic scenario, i.e., the information exchange between the Coordinator and the SEAs is instantaneous as well as the SEAs responses are assumed to be immediate. The FCR, aFRR, and mFRR services are provided by a single SEA considering the time response of each one. Figure 7 presents this operation, it depicts how the BSP performs the services when the SO requests a power reduction of  $r=40$  kW from minute 30 to 90. The Baseline power is 305.82 kW, the ideal RT power is 265.82 kW, while the BSP RT average power is 265.88 kW, achieving an average error of 22.6 W and standard deviation of 0.78 kW.

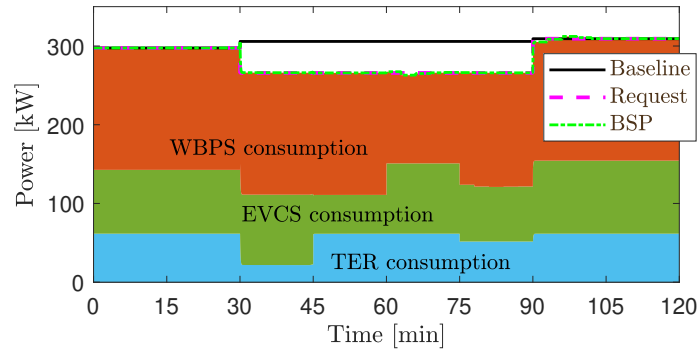
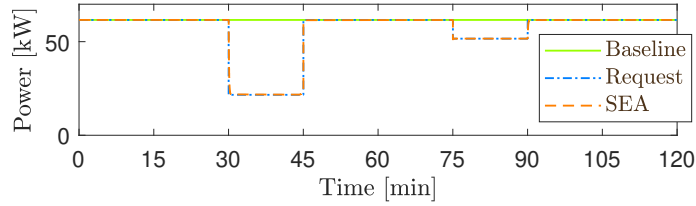

Figure 7: BSP performance in Frequency restoration operation, (*Case 1.a*).

Moreover, Figure 8 shows the power capacity of each SEA. Likewise, the Coordinator operation requests are observed, in which the planning phase operation is noticed every  $\Delta t_P$  at the minutes 30, 45, 60, and 75. Indeed, the TER-SEA is called to modify its capacity at minute 30 from 62 kW to 22 kW in the following 15 min service provision (see Figure 8a). In the

EVCS-SEA, the initial capacity is 81 kW; however, the baseline power for the restoration process hour is 89 kW, leading to 49 kW when providing the service from minute 45 to minute 60 (see Figure 8b). Regarding the WBPS-SEA, the initial capacity is 155 kW, and the maximum deviation (60 - 75 min) reaches 112 kW (see Figure 8c). Notice that the tuning phase operation is not managing the SEAs variations between minutes 30 and 75, this is because of the *Case 1.a* nature, in which only one SEA is operated by the Coordinator every 15 min. However, the last 15 min service (from minutes 75 to 90) all the SEAs are called to modify their power demand. The tuning phase operation takes action in the EVCS-SEA to reduce the WBPS-SEA variations.



(a) TER SEA.

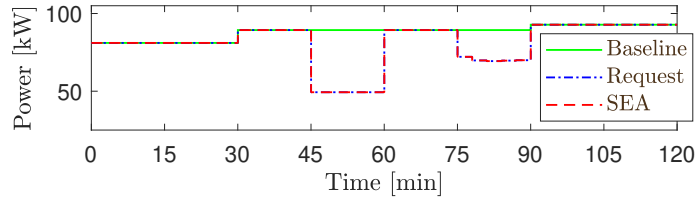

(b) EVCS SEA.

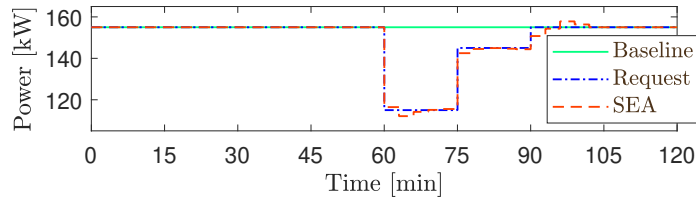

(c) WBPS SEA.

Figure 8: Single aggregator response in Frequency restoration operation for *Case 1.a*.

Figure 9 shows the percentage of TER and WBPS systems whose flexibility is activated by the SEA to follow the power request. The maximum

power deviation of the BSP is computed as the maximum power the TER-SEA can provide, in this case for 15 minutes. In addition, a ramp-down phase is considered at the end of the service to avoid a rebound effect of the BSP.

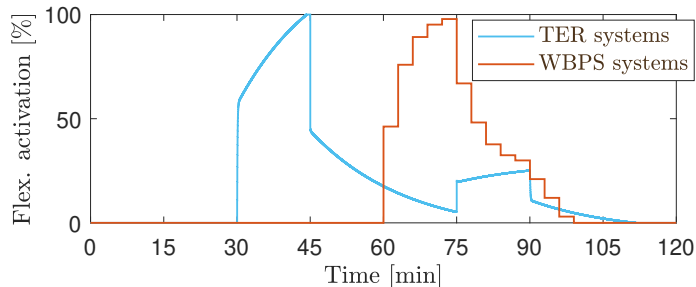

Figure 9: Flexibility activation of TER and WBPS systems (*Case 1.a*).

Concerning the performance of the EVCS-SEA (see Figure 8b), in the time period between minute 75 and minute 90 the power is not constant. In fact, in this period the Coordinator modifies the EVCS consumption depending on the other SEAs consumption. In particular, the WBPS-SEA has small variations when following its request; then, the EVCS is operated every Tuning phase of the Coordinator operation to maintain the balance. Notice that the baseline power schedule varies at each hour.

#### 4.2.2. Case 1.b

In this case, the Coordinator manages the SEAs with a strategy similar to the one presented by [62], considering ramps rates and times per service (see Figure 1). This case follows an idealistic scenario as in *Case 1.a*. Figure 10 presents the power response of the BSP when aggregating the SEAs power. The SO requests a power reduction of  $r=57$  kW, 17 kW higher than in *Case 1.a*. The baseline power is 305.82 kW (the same as *Case 1.a*), the ideal RT power is 248.82 kW, while the BSP RT average power is 249.00 kW achieving an average error of 71.5 W and standard deviation of 0.10 kW (lower than in *Case 1.a*).

Figure 11 shows the power capacity of each SEA. The planing phase operation is carried out every  $\Delta t_P$  as in the *Case 1.a*. Nevertheless, the Coordinator manages all the SEAs every 15 min instead of one SEA per  $k_P$ . The SEAs initial capacities are the same as in *Case 1.a*; however, the maximum power deviations are higher (but for less time). The TER-SEA

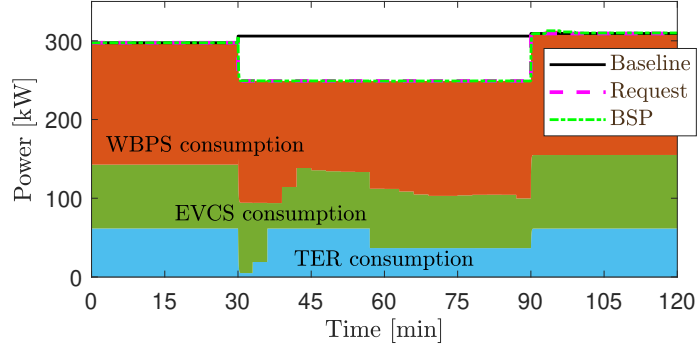

Figure 10: BSP performance in Frequency restoration operation, (*Case 1.b*).

and the EVCS-SEA reduce the power as requested by the coordinator, but only for 3 min, while the maximum reduction in WBPS-SEA is 44 kW.

The TER-SEA is the first SEA commanded to modify consumption (see Figure 11a), as it is the only one that can provide the FCR energy service. Therefore, the maximum power is defined by the maximum capacity of this SEA in the specific time window ( $\Delta t_T = 3$  min in this case). Moreover, the Coordinator, in the tuning phase is constantly changing the requested EVCS-SEA power (see Figure 11b) due to the variations of the WBPS-SEA (see Figure 11c).

The percentage of systems changing temperature set-point (for TERs) as well as the percentage of systems changing pressure set-point (for WBPSs) are depicted in Figure 12. Also in this case, a ramp-down phase is considered to avoid a rebound effect at the end of the BSP energy provision.

#### 4.2.3. Case 2

This case study assesses the provision of the energy services mFRR and RR. In particular, the mFRR service looks to stabilise the frequency of the electricity grid by considering a 12.5 min interval of full activation, i.e., much longer than in *Case 1* (30 s). Then, this allows the BSP to provide a higher capacity due to the participation of all the SEAs and not only the faster. In addition, this case follows a realistic scenario that considers the commands propagation delays.

Figure 13 depicts the BSP. It can be seen that the BSP stabilises after 6 min when all the SEAs are following its Coordinator requests. In this case, the SO power reduction requests is  $r = 122.78$  kW, that is, 82.78 kW higher than in *Case 1.a*, and 65.78 kW higher than in *Case 1.b*. The baseline is the

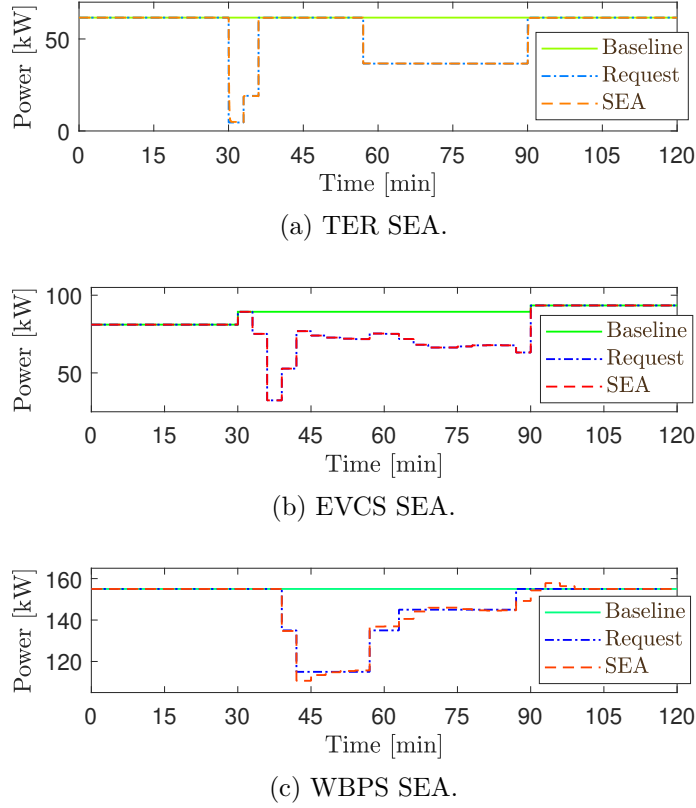

Figure 11: Single aggregator response in Frequency restoration operation for *Case 1.b*.

same than in *Case 1*, i.e., 305.82 kW. The expected RT power is 183.04 kW, whereas the actual average BSP power is 182.93 kW.

Figure 14 shows the power capacity of each SEA, taking into account the commands propagation delays. The initial power requested at minute 30 by the Coordinator to the SEAs in the operation planning phase operation are:  $r_{TER} = 27.72$  kW,  $r_{EVCS} = 56.00$  kW, and  $r_{WBPS} = 39.06$  kW. The WBPS-SEA request is not modified up to the end of the service (see Figure 14c), whereas the requests for the EVCS-SEA and the TER-SEA are modified at minute 75 due to a lack of flexibility reported by the EVCS-SEA. Notice that the TER-SEA is used to handle the other SEAs set-point change, e.g., until the EVCS-SEA achieves the new set-point at minute 78 (see Figure 14b). In the same way, the WBPS-SEA variations are managed in the tuning phases by modifying the TER-SEA power (see Figure 14a).

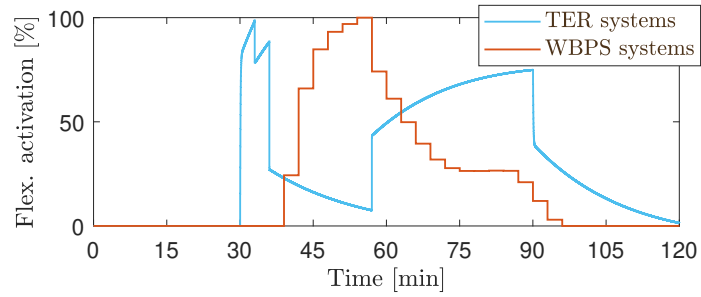

Figure 12: Flexibility activation of TER and WBPS systems (*Case 1.b*).

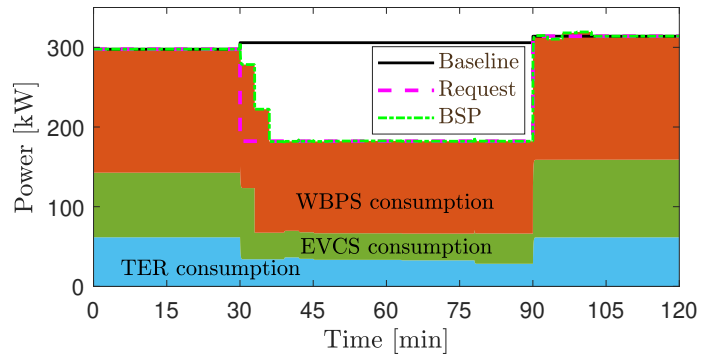
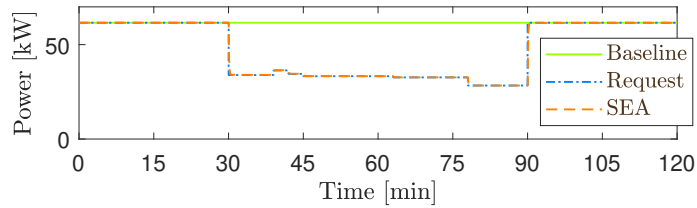
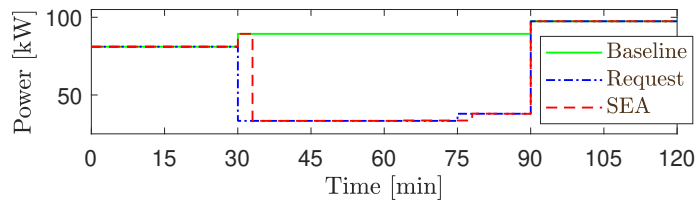

Figure 13: BSP performance in Frequency restoration operation (*Case 2*).



(a) TER SEA.



(b) EVCS SEA.

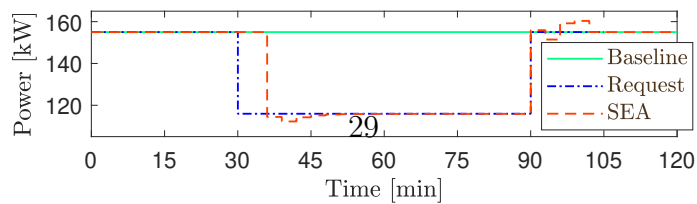

(c) WBPS SEA.

Figure 14: Single aggregator response in Frequency restoration operation for *Case 2*.

The percentage of systems changing the temperature set-point (TERs) as well as the percentage of systems changing pressure set-point (WBPS) are depicted in Figure 15.

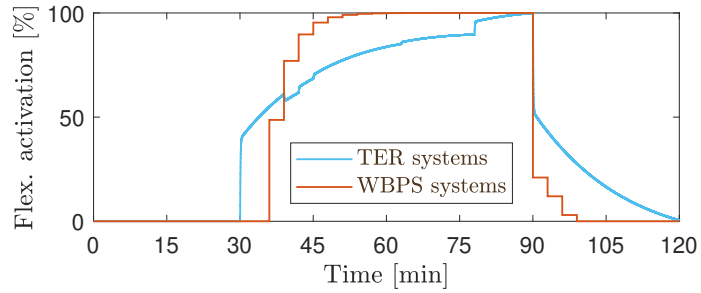

Figure 15: Flexibility activation of TER and WBPS systems (*Case 2*).

Finally, Table 4 summarises the main differences between *Case 1.a*, *Case 1.b*, and *Case 2*. It can be seen that *Case 1.b* considers a higher power reduction when considering fast services (*Case 1*) due to the duration of the first interval when the TER-SEA is activated (3 min). However, *Case 2* presents a much higher capacity provision due to the longer activation time. In *Case 1.b* and *Case 2* the standard deviations are lower because the tuning phase operation is constantly correcting the power deviations through SEAs set-points. In addition, the tracking average error is higher in *Case 1.b*. Nevertheless, in all cases, the error is lower than 0.03%.

Table 4: Comparison between *Case 1.a*, *Case 1.b*, and *Case 2*.

Parameter	<i>Case 1.a</i>	<i>Case 1.b</i>	<i>Case 2</i>
Max power reduction	40 kW	57 kW	122.78 kW
Activation time	20"	24"	6'2"
Tracking average error	26.6 W	71.5 W	60.1 W
Standard deviation	0.78 kW	0.10 kW	0.24 kW

## 5. Conclusions and Future Work

This paper has presented a unified framework of aggregation for distributed energy sources, through a two-level coordination model for a Balancing Service Provider (BSP). In particular, the low level aggregation is



asset-based, i.e., there is a set of Specialised Energy Aggregators (SEAs), whereas the high-level aggregation is provided by a single Coordinator.

The Coordinator interacts with the System Operator (SO) for providing balancing services to the electrical grid within the European context of electricity balancing. Each SEA aggregates different balancing responsible parties characterised by the same asset (e.g., electric vehicle chargers) and interacts with the Coordinator. All the SEAs and the Coordinator interact in a two-level hierarchical structure that forms a BSP. The proposed interaction framework guarantees to the users a high level of information privacy protection, because the user-related information is only used by the single SEA, while each SEA sends only aggregated information to the upper level, without the possibility to recognise the single user behaviour.

The Coordinator operation is formulated as a two-phase operation. The first phase, called Planning phase, generates the scheduled energy consumption of every SEA for the next dispatch time interval. The second phase, called Tuning phase, allows to correct the unexpected SEA energy consumption variations, which are caused by the uncertainties of the flexible loads. Within this framework, the main information exchange parameters between the Coordinator and its main stakeholders, the SO and every SEA are defined. The information used is restricted to the power capacities and the balancing services to be provided. A control algorithm for the Coordinator has been derived, considering an optimal feedback control sequence. The aim of the algorithm is to minimise the power baseline-following error by taking into account the balancing service requests from the system operator.

A case study with three different SEAs has been presented to assess the validity of the solution. In the model, the type of loads managed by each SEA greatly differ in terms of technical characteristics, i.e., thermoelectric refrigeration units, electric vehicle charging stations, and water booster pressure systems.

The BSP performance has been assessed in diverse simulation campaigns for frequency restoration operations. The simulations illustrate the provision of fast services, like frequency containment reserves, as well as longer term services as replacement reserves. It was found that a higher capacity for the replacement reserve service can be provided due to the participation of multiple SEAs in this service, while only the fastest SEAs can provide fast restoration services.

Future works will consider new services linked to the fast-frequency reserve and the inertial support, which are much more power-intensive and

more compatible with assets which may be used as grid flexibility assets, yet presenting a different primary use.

## 6. Acknowledgements

This research was partially funded by Pontificia Universidad Javeriana through the research project titled “Remuneración y operación óptima de esquemas agregador-prosumidor en sistemas de energía”, identified with ID 20271.

## References

- [1] M. Z. Degefa, I. B. Sperstad, H. Sæle, Comprehensive classifications and characterizations of power system flexibility resources, *Electric Power Systems Research* 194 (2021) 107022. doi:<https://doi.org/10.1016/j.epsr.2021.107022>.  
URL <https://www.sciencedirect.com/science/article/pii/S037877962100002X>
- [2] A. Ulbig, G. Andersson, Analyzing operational flexibility of electric power systems, *International Journal of Electrical Power Energy Systems* 72 (2015) 155–164, the Special Issue for 18th Power Systems Computation Conference. doi:<https://doi.org/10.1016/j.ijepes.2015.02.028>.  
URL <https://www.sciencedirect.com/science/article/pii/S0142061515001118>
- [3] Y. V. Makarov, C. Loutan, J. Ma, P. de Mello, Operational impacts of wind generation on california power systems, *IEEE Transactions on Power Systems* 24 (2) (2009) 1039–1050. doi:[10.1109/TPWRS.2009.2016364](https://doi.org/10.1109/TPWRS.2009.2016364).
- [4] S. Riaz, P. Mancarella, Modelling and characterisation of flexibility from distributed energy resources, *IEEE Transactions on Power Systems* 37 (1) (2022) 38–50. doi:[10.1109/TPWRS.2021.3096971](https://doi.org/10.1109/TPWRS.2021.3096971).
- [5] H. Nosair, F. Bouffard, Reconstructing operating reserve: Flexibility for sustainable power systems, *IEEE Transactions on Sustainable Energy* 6 (4) (2015) 1624–1637. doi:[10.1109/TSTE.2015.2462318](https://doi.org/10.1109/TSTE.2015.2462318).

- [6] S. Wang, C. Zhao, L. Fan, R. Bo, Distributionally robust unit commitment with flexible generation resources considering renewable energy uncertainty, *IEEE Transactions on Power Systems* (2022) in press. doi:10.1109/TPWRS.2022.3149506.
- [7] J. Li, F. Liu, Z. Li, C. Shao, X. Liu, Grid-side flexibility of power systems in integrating large-scale renewable generations: A critical review on concepts, formulations and solution approaches, *Renewable and Sustainable Energy Reviews* 93 (2018) 272–284. doi:<https://doi.org/10.1016/j.rser.2018.04.109>.  
URL <https://www.sciencedirect.com/science/article/pii/S1364032118303289>
- [8] S. H. Tindemans, V. Trovato, G. Strbac, Decentralized control of thermostatic loads for flexible demand response, *IEEE Transactions on Control Systems Technology* 23 (5) (2015) 1685–1700. doi:10.1109/TCST.2014.2381163.
- [9] H. Hao, B. M. Sanandaji, K. Poolla, T. L. Vincent, Aggregate flexibility of thermostatically controlled loads, *IEEE Transactions on Power Systems* 30 (1) (2015) 189–198. doi:10.1109/TPWRS.2014.2328865.
- [10] C. Diaz, F. Ruiz, D. Patino, Modeling and control of water booster pressure systems as flexible loads for demand response, *Applied Energy* 204 (2017) 106–116. doi:10.1016/j.apenergy.2017.06.094.  
URL <http://dx.doi.org/10.1016/j.apenergy.2017.06.094>
- [11] G. Fambri, M. Badami, D. Tsagkrasoulis, V. Katsiki, G. Giannakis, A. Papanikolaou, Demand flexibility enabled by virtual energy storage to improve renewable energy penetration, *Energies* 13 (19) (2020). doi:10.3390/en13195128.  
URL <https://www.mdpi.com/1996-1073/13/19/5128>
- [12] G. Chicco, S. Riaz, A. Mazza, P. Mancarella, Flexibility from distributed multienergy systems, *Proceedings of the IEEE* 108 (9) (2020) 1496–1517. doi:10.1109/JPROC.2020.2986378.
- [13] M. Badami, G. Fambri, Optimising energy flows and synergies between energy networks, *Energy* 173 (2019) 400–412. doi:<https://doi.org/10.1016/j.energy.2019.02.007>.

URL <https://www.sciencedirect.com/science/article/pii/S0360544219301963>

- [14] I. Pavić, T. Capuder, I. Kuzle, A comprehensive approach for maximizing flexibility benefits of electric vehicles, *IEEE Systems Journal* 12 (3) (2018) 2882–2893. doi:10.1109/JSYST.2017.2730234.
- [15] I. A. Sajjad, G. Chicco, R. Napoli, Definitions of demand flexibility for aggregate residential loads, *IEEE Transactions on Smart Grid* 7 (6) (2016) 2633–2643. doi:10.1109/TSG.2016.2522961.
- [16] G. Reynders, R. Amaral Lopes, A. Marszal-Pomianowska, D. Aelenei, J. Martins, D. Saelens, Energy flexible buildings: An evaluation of definitions and quantification methodologies applied to thermal storage, *Energy and Buildings* 166 (2018) 372–390. doi:<https://doi.org/10.1016/j.enbuild.2018.02.040>.  
URL <https://www.sciencedirect.com/science/article/pii/S037877881732947X>
- [17] J. T. Hughes, A. D. Domínguez-García, K. Poolla, Identification of virtual battery models for flexible loads, *IEEE Transactions on Power Systems* 31 (6) (2016) 4660–4669. doi:10.1109/TPWRS.2015.2505645.
- [18] J. Villar, R. Bessa, M. Matos, Flexibility products and markets: Literature review, *Electric Power Systems Research* 154 (2018) 329–340. doi:<https://doi.org/10.1016/j.epsr.2017.09.005>.  
URL <https://www.sciencedirect.com/science/article/pii/S0378779617303723>
- [19] G. Chicco, A. Mazza, New insights for setting up contractual options for demand side flexibility, *Journal of Engineering Sciences and Innovation* 4 (4) (2019) 381–398.
- [20] D. Energy U.S., Benefits of demand response in electricity markets and recommendations for achieving them, Tech. Rep. February (2006).
- [21] R. Henríquez, G. Wenzel, D. E. Olivares, M. Negrete-Pincetic, Participation of demand response aggregators in electricity markets: Optimal portfolio management, *IEEE Transactions on Smart Grid* 9 (5) (2018) 4861–4871. doi:10.1109/TSG.2017.2673783.

- [22] G. Tsaousoglou, J. S. Giraldo, P. Pinson, N. G. Paterakis, Mechanism design for fair and efficient dso flexibility markets, *IEEE Transactions on Smart Grid* 12 (3) (2021) 2249–2260. doi:10.1109/TSG.2020.3048738.
- [23] I. Lampropoulos, T. Alskaf, J. Blom, W. van Sark, A framework for the provision of flexibility services at the transmission and distribution levels through aggregator companies, *Sustainable Energy, Grids and Networks* 17 (2019) 100187. doi:<https://doi.org/10.1016/j.segan.2018.100187>.  
URL <https://www.sciencedirect.com/science/article/pii/S2352467718300432>
- [24] C. A. Correa-Florez, A. Michiorri, G. Kariniotakis, Optimal Participation of Residential Aggregators in Energy and Local Flexibility Markets, *IEEE Trans. Smart Grid* 11 (2) (2020) 1644–1656. doi:10.1109/TSG.2019.2941687.
- [25] M. Rayati, M. Bozorg, R. Cherkaoui, Coordinating strategic aggregators in an active distribution network for providing operational flexibility, *Electric Power Systems Research* 189 (106737) (2020) 1–8. doi:10.1016/j.epsr.2020.106737.  
URL <https://doi.org/10.1016/j.epsr.2020.106737https://linkinghub.elsevier.com/retrieve/pii/S037877962030540X>
- [26] K. Ma, D. Wang, J. Lian, D. Wu, S. Katipamula, Market-based Co-optimization of Energy and Ancillary Services with Distributed Energy Resource Flexibilities, in: *Proc. IEEE PES Transmission and Distribution Conference, 2020*, pp. 1–5. doi:10.1109/TD39804.2020.9299658.
- [27] M. Yazdani-Damavandi, N. Neyestani, M. Shafie-khah, J. Contreras, J. P. S. Catalão, Strategic behavior of multi-energy players in electricity markets as aggregators of demand side resources using a bi-level approach, *IEEE Transactions on Power Systems* 33 (1) (2018) 397–411. doi:10.1109/TPWRS.2017.2688344.
- [28] J. Vuelvas, F. Ruiz, G. Gruosso, A time-of-use pricing strategy for managing electric vehicle clusters, *Sustainable Energy, Grids and Networks* 25 (100411) (2021) 1–9. doi:10.1016/j.segan.2020.100411.  
URL <https://doi.org/10.1016/j.segan.2020.100411>

- [29] X. Wang, Y. Liu, J. Liu, Y. Jia, Y. Xiang, Thermally controllable demand response with multiple load aggregators, *Electric Power Systems Research* 179 (106102) (2020) 1–10. doi:10.1016/j.epsr.2019.106102. URL <https://doi.org/10.1016/j.epsr.2019.106102>
- [30] S. K. Singh, P. B. Kiran, N. M. Pindoriya, ADMM algorithm based distributed energy management in active distribution network, in: *2020 21st National Power Systems Conference*, 2020, pp. 1–6. doi:10.1109/NPSC49263.2020.9331751.
- [31] A. M. Sanchez, G. E. Coria, A. A. Romero, S. R. Rivera, An improved methodology for the hierarchical coordination of PEV Charging, *IEEE Access* 7 (2019) 141754–141765. doi:10.1109/ACCESS.2019.2943295.
- [32] Z. Xu, Z. Hu, Y. Song, W. Zhao, Y. Zhang, Coordination of PEVs charging across multiple aggregators, *Applied Energy* 136 (2014) 582–589. doi:10.1016/j.apenergy.2014.08.116. URL <http://dx.doi.org/10.1016/j.apenergy.2014.08.116>
- [33] K. Meng, Z. Y. Dong, Z. Xu, Y. Zheng, D. J. Hill, Coordinated dispatch of virtual energy storage systems in smart distribution networks for loading management, *IEEE Transactions on Systems, Man, and Cybernetics: Systems* 49 (4) (2019) 776–786. doi:10.1109/TSMC.2017.2690911.
- [34] Z. Yi, Y. Xu, H. Wang, L. Sang, Coordinated operation strategy for a virtual power plant with multiple der aggregators, *IEEE Transactions on Sustainable Energy* 12 (4) (2021) 2445–2458. doi:10.1109/TSTE.2021.3100088.
- [35] G. Tsaousoglou, P. Makris, E. Varvarigos, Electricity market policies for penalizing volatility and scheduling strategies: The value of aggregation, flexibility, and correlation, *Sustainable Energy, Grids and Networks* 12 (2017) 57–68. doi:<https://doi.org/10.1016/j.segan.2017.09.004>. URL <https://www.sciencedirect.com/science/article/pii/S2352467716302260>
- [36] M. Yazdani-Damavandi, N. Neyestani, G. Chicco, M. Shafie-khah, J. P. S. Catalão, Aggregation of distributed energy resources under the concept of multienergy players in local energy systems,

- IEEE Transactions on Sustainable Energy 8 (4) (2017) 1679–1693. doi:10.1109/TSTE.2017.2701836.
- [37] V. Rigoni, D. Flynn, A. Keane, Coordinating demand response aggregation with lv network operational constraints, IEEE Transactions on Power Systems 36 (2) (2021) 979–990. doi:10.1109/TPWRS.2020.3014144.
- [38] Z. Xu, T. Deng, Z. Hu, Y. Song, J. Wang, Data-driven pricing strategy for demand-side resource aggregators, IEEE Transactions on Smart Grid 9 (1) (2018) 57–66. doi:10.1109/TSG.2016.2544939.
- [39] J. Hu, J. Cao, J. M. Guerrero, T. Yong, J. Yu, Improving frequency stability based on distributed control of multiple load aggregators, IEEE Transactions on Smart Grid 8 (4) (2017) 1553–1567. doi:10.1109/TSG.2015.2491340.
- [40] P. Afzali, M. Rashidinejad, A. Abdollahi, A. Bakhshai, Risk-constrained bidding strategy for demand response, green energy resources, and plug-in electric vehicle in a flexible smart grid, IEEE Systems Journal 15 (1) (2021) 338–345. doi:10.1109/JSYST.2020.2964854.
- [41] V. A. Evangelopoulos, T. P. Kontopoulos, P. S. Georgilakis, Heterogeneous aggregators competing in a local flexibility market for active distribution system management: A bi-level programming approach, International Journal of Electrical Power Energy Systems 136 (2022) 107639. doi:<https://doi.org/10.1016/j.ijepes.2021.107639>.  
URL <https://www.sciencedirect.com/science/article/pii/S0142061521008711>
- [42] T. Peirelinck, C. Hermans, F. Spiessens, G. Deconinck, Domain randomization for demand response of an electric water heater, IEEE Transactions on Smart Grid 12 (2) (2021) 1370–1379. doi:10.1109/TSG.2020.3024656.
- [43] X. Lu, X. Ge, K. Li, F. Wang, H. Shen, P. Tao, J. Hu, J. Lai, Z. Zhen, M. Shafie-khah, J. P. S. Catalão, Optimal bidding strategy of demand response aggregator based on customers’ responsiveness behaviors modeling under different incentives, IEEE Transactions on Industry Applications 57 (4) (2021) 3329–3340. doi:10.1109/TIA.2021.3076139.

- [44] X. Lu, K. W. Chan, S. Xia, M. Shahidehpour, W. H. Ng, An operation model for distribution companies using the flexibility of electric vehicle aggregators, *IEEE Transactions on Smart Grid* 12 (2) (2021) 1507–1518. doi:10.1109/TSG.2020.3037053.
- [45] M. Mousavi, M. Wu, A dso framework for market participation of der aggregators in unbalanced distribution networks, *IEEE Transactions on Power Systems* (2022) in press.
- [46] M. Song, W. Sun, Y. Wang, M. Shahidehpour, Z. Li, C. Gao, Hierarchical scheduling of aggregated tcl flexibility for transactive energy in power systems, *IEEE Transactions on Smart Grid* 11 (3) (2020) 2452–2463. doi:10.1109/TSG.2019.2955852.
- [47] J.-M. Clairand, M. González-Rodríguez, I. Cedeño, G. Escrivá-Escrivá, A charging station planning model considering electric bus aggregators, *Sustainable Energy, Grids and Networks* 30 (2022) 100638. doi:<https://doi.org/10.1016/j.segan.2022.100638>.  
URL <https://www.sciencedirect.com/science/article/pii/S2352467722000200>
- [48] J. E. Contreras-Ocaña, M. R. Sarker, M. A. Ortega-Vazquez, Decentralized coordination of a building manager and an electric vehicle aggregator, *IEEE Transactions on Smart Grid* 9 (4) (2018) 2625–2637. doi:10.1109/TSG.2016.2614768.
- [49] D. Fioriti, A. Frangioni, D. Poli, Optimal sizing of energy communities with fair revenue sharing and exit clauses: Value, role and business model of aggregators and users, *Applied Energy* 299 (2021) 117328. doi:<https://doi.org/10.1016/j.apenergy.2021.117328>.  
URL <https://www.sciencedirect.com/science/article/pii/S0306261921007376>
- [50] M. Di Somma, G. Graditi, P. Siano, Optimal bidding strategy for a der aggregator in the day-ahead market in the presence of demand flexibility, *IEEE Transactions on Industrial Electronics* 66 (2) (2019) 1509–1519. doi:10.1109/TIE.2018.2829677.
- [51] W. Pei, Y. Du, W. Deng, K. Sheng, H. Xiao, H. Qu, Optimal bidding strategy and intramarket mechanism of microgrid aggregator in real-



- time balancing market, *IEEE Transactions on Industrial Informatics* 12 (2) (2016) 587–596. doi:10.1109/TII.2016.2522641.
- [52] J. Hu, G. Yang, C. Ziras, K. Kok, Aggregator operation in the balancing market through network-constrained transactive energy, *IEEE Transactions on Power Systems* 34 (5) (2019) 4071–4080. doi:10.1109/TPWRS.2018.2874255.
- [53] M. González Vayá, G. Andersson, Optimal bidding strategy of a plug-in electric vehicle aggregator in day-ahead electricity markets under uncertainty, *IEEE Transactions on Power Systems* 30 (5) (2015) 2375–2385. doi:10.1109/TPWRS.2014.2363159.
- [54] G. E. Asimakopoulou, A. G. Vlachos, N. D. Hatziargyriou, Hierarchical decision making for aggregated energy management of distributed resources, *IEEE Transactions on Power Systems* 30 (6) (2015) 3255–3264. doi:10.1109/TPWRS.2015.2390412.
- [55] E. G. Kardakos, C. K. Simoglou, A. G. Bakirtzis, Optimal offering strategy of a virtual power plant: A stochastic bi-level approach, *IEEE Transactions on Smart Grid* 7 (2) (2016) 794–806. doi:10.1109/TSG.2015.2419714.
- [56] P. Sheikahmadi, S. Bahramara, The participation of a renewable energy-based aggregator in real-time market: A bi-level approach, *Journal of Cleaner Production* 276 (2020) 123149. doi:<https://doi.org/10.1016/j.jclepro.2020.123149>.  
URL <https://www.sciencedirect.com/science/article/pii/S0959652620331942>
- [57] J. E. Contreras-Ocaña, M. A. Ortega-Vazquez, B. Zhang, Participation of an energy storage aggregator in electricity markets, *IEEE Transactions on Smart Grid* 10 (2) (2019) 1171–1183. doi:10.1109/TSG.2017.2736787.
- [58] F. Wang, X. Ge, K. Li, Z. Mi, Day-ahead market optimal bidding strategy and quantitative compensation mechanism design for load aggregator engaging demand response, *IEEE Transactions on Industry Applications* 55 (6) (2019) 5564–5573. doi:10.1109/TIA.2019.2936183.

- [59] P. N. Ovalle, J. Vuelvas, A. Fajardo, C. A. Correa-Flórez, F. Ruiz, Optimal portfolio selection methodology for a demand response aggregator, *Energies* 14 (23) (2021). doi:10.3390/en14237923.  
URL <https://www.mdpi.com/1996-1073/14/23/7923>
- [60] C. Diaz-Londono, C. A. Correa-Florez, J. Vuelvas, A. Mazza, F. Ruiz, G. Chicco, Coordination of aggregators for flexibility provision: A conceptual framework, in: 2021 International Conference on Smart Energy Systems and Technologies (SEST), 2021, pp. 1–6. doi:10.1109/SEST50973.2021.9543190.  
URL <https://ieeexplore.ieee.org/document/9543190>
- [61] European Network of Transmission System Operators for Electricity (ENTSO-E), Tech. rep.
- [62] European Commission, Commission Regulation (EU) 2017/1485 establishing a guideline on electricity transmission system operation, *Official Journal of the European Union* L 220 (2017) 1–120.
- [63] ENTSO-E, All TSOs’ proposal for the implementation framework for the exchange of balancing energy from frequency restoration reserves with automatic activation in accordance with Article 21 of Commission Regulation (EU) 2017/2195 establishing a guideline on electr, Tech. rep. (2018).
- [64] ENTSO-E, All TSOs’ proposal for the implementation framework for a European platform for the exchange of balancing energy from frequency restoration reserves with manual activation in accordance with Article 20 of Commission Regulation (EU) 2017/2195 establishing , Tech. rep. (2018).
- [65] ENTSO-E, The proposal of all TSO performing the reserve replacement process for the implementation framework for the exchange of balancing energy from Replacement Reserves in accordance with Article 19 of Commission Regulation (EU) 2017/2195, Tech. rep. (2018).
- [66] The European Commission, Commission Regulation (EU) 2017/2195 of 23 November 2017 establishing a guideline on electricity balancing., *Official Journal of the European Union* 2017 (November) (2017) 312/6 – 312/53.

- [67] ENTSO-E, Electricity balancing, [https://www.entsoe.eu/network\\_codes/eb/](https://www.entsoe.eu/network_codes/eb/), accessed: 2022-2-26.
- [68] ENTSO-E, Frequency containment reserves (fcr), [https://www.entsoe.eu/network\\_codes/eb/fcr/](https://www.entsoe.eu/network_codes/eb/fcr/), accessed: 2022-2-26.
- [69] ENTSO-E, Picasso, [https://www.entsoe.eu/network\\_codes/eb/picasso/](https://www.entsoe.eu/network_codes/eb/picasso/), accessed: 2022-2-26.
- [70] ENTSO-E, Manually activated reserves initiative, [https://www.entsoe.eu/network\\_codes/eb/mari/](https://www.entsoe.eu/network_codes/eb/mari/), accessed: 2022-2-26.
- [71] ENTSO-E, Terre, [https://www.entsoe.eu/network\\_codes/eb/terre/](https://www.entsoe.eu/network_codes/eb/terre/), accessed: 2022-2-26.
- [72] European Commission, Regulation (eu) 2019/943 of the european parliament and of the council of 5 june 2019 on the internal market for electricity, Official Journal of the European Union L 158 (2019) 54–124. URL <https://eur-lex.europa.eu/legal-content/EN/TXT/?uri=CELEX%3A32019R0943>
- [73] European Commission, Directive (eu) 2019/944 of the european parliament and of the council of 5 june 2019 on common rules for the internal mar- ket for electricity and amending directive 2012/27/eu, Official Journal of the European Union L 158 (2019) 125–199. URL [https://eur-lex.europa.eu/legal-content/EN/TXT/?uri=uriserv:OJ.L\\_.2019.158.01.0125.01.ENG&toc=OJ:L:2019:158:TOC](https://eur-lex.europa.eu/legal-content/EN/TXT/?uri=uriserv:OJ.L_.2019.158.01.0125.01.ENG&toc=OJ:L:2019:158:TOC)
- [74] European Commission, Clean energy for all europeans package, [https://energy.ec.europa.eu/topics/energy-strategy/clean-energy-all-europeans-package\\_en](https://energy.ec.europa.eu/topics/energy-strategy/clean-energy-all-europeans-package_en), accessed: 2022-1-28.
- [75] P. D. Lund, J. Lindgren, J. Mikkola, J. Salpakari, Review of energy system flexibility measures to enable high levels of variable renewable electricity, *Renewable and Sustainable Energy Reviews* 45 (2015) 785–807. doi:<https://doi.org/10.1016/j.rser.2015.01.057>. URL <https://www.sciencedirect.com/science/article/pii/S1364032115000672>
- [76] C. Diaz-Londono, D. Enescu, F. Ruiz, A. Mazza, Experimental Modeling and Aggregation Strategy for Thermoelectric Refrigeration Units as

Flexible Loads, *Applied Energy* (115065) 1–17.

URL <https://www.sciencedirect.com/science/article/pii/S0306261920305778>

- [77] C. Diaz-Londono, L. Colangelo, F. Ruiz, D. Patino, C. Novara, G. Chicco, Optimal Strategy to Exploit the Flexibility of an Electric Vehicle Charging Station, *Energies* 12 (20) (2019) 1–29. doi:10.3390/en12203834.  
URL <https://doi.org/10.3390/en12203834>