



TITLE:

Effect of acidity on attenuation performance of sandy soil amended with granular calcium-magnesium composite

AUTHOR(S):

Gathuka, Lincoln W.; Kato, Tomohiro; Takai, Atsushi; Flores, Giancarlo; Inui, Toru; Katsumi, Takeshi

CITATION:

Gathuka, Lincoln W. ...[et al]. Effect of acidity on attenuation performance of sandy soil amended with granular calcium-magnesium composite. *Soils and Foundations* 2021, 61(4): 1099-1111

ISSUE DATE:

2021-08

URL:

<http://hdl.handle.net/2433/276066>

RIGHT:

© 2021 Production and hosting by Elsevier B.V. on behalf of The Japanese Geotechnical Society.; This is an open access article under the Creative Commons Attribution-NonCommercial-NoDerivatives 4.0 International license.



Available online at www.sciencedirect.com

ScienceDirect

Soils and Foundations 61 (2021) 1099–1111

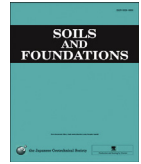

www.elsevier.com/locate/sandf

Technical Paper

Effect of acidity on attenuation performance of sandy soil amended with granular calcium-magnesium composite

Lincoln W. Gathuka^{a,*}, Tomohiro Kato^a, Atsushi Takai^a, Giancarlo Flores^b, Toru Inui^c
Takeshi Katsumi^a

^a Graduate School of Global Environmental Studies, Kyoto University, Yoshida-honmachi, Sakyo-ku, Kyoto 606-8501, Japan

^b Department of Civil Engineering, Universidad de Ingeniería y Tecnología, Jr. Medrano Silva 165, Barranco, Lima, Peru

^c Graduate School of Engineering, Osaka University, 2-1 Yamadaoka, Suita-shi, Osaka 565-0871, Japan

Received 21 July 2020; received in revised form 13 April 2021; accepted 5 May 2021

Available online 16 June 2021

Abstract

Utilising naturally contaminated soils and rocks is essential for significantly reducing geo-waste. However, there are no well-established concepts regarding the methods or countermeasures for utilising these soils and rocks, which would realise cost-effectiveness and environmental safety. Therefore, several researches focusing on the attenuation layer method have recently been undertaken. This method involves installing an attenuation layer between the contaminated materials and the ground to prevent ground contamination due to the attenuation capacity. A critical issue in the attenuation layer's design is to evaluate the attenuation performance of the layer material against target chemicals. Several important concerns and questions need to be solved when evaluating the attenuation performance. One is how the acidic leachate might diminish the layer material's attenuation performance. This paper presents the attenuation performance of a soil amended with a granular calcium-magnesium composite against acidic leachate. Batch and column tests, employing arsenic solutions of pH 2, 4 and 6, were applied to evaluate its attenuation performance. Using Freundlich parameter K as an index, the soil's attenuation performance was determined to have improved by at least 40% after the addition of the agent, even when the agent content was 5%. The amended soil's attenuation performance should be similar if the leachate pH is pH 6–4, although it might reduce by up to ~30% for pH < 4. Moreover, the amended soil can buffer the acid to pH > 6. If the attenuation layer buffers the acid and provides the leachate with pH > 6, it will assure that the original ground's attenuation capacity is utilised. Considering this work's findings, amended soil can be employed as material for the attenuation layer.

© 2021 Production and hosting by Elsevier B.V. on behalf of The Japanese Geotechnical Society. This is an open access article under the CC BY-NC-ND license (<http://creativecommons.org/licenses/by-nc-nd/4.0/>).

Keywords: Arsenic; Attenuation layer; Naturally contaminated soils; pH buffering

1. Introduction

Utilising excavated soils and rocks for embankments and other geotechnical applications is highly encouraged for significantly reducing the amount of geo-waste (Katsumi et al., 2010; Magnusson et al., 2019). Benefits include prolonging the life of soil fills at soil disposal sites and preventing accidents that may occur due to the rapid filling of soil fills to extreme heights (Katsumi et al., 2019). However, utilisation projects are sometimes delayed

Peer review under responsibility of The Japanese Geotechnical Society.

* Corresponding author.

E-mail addresses: gathuka.lincolnwaweru.4a@kyoto-u.ac.jp (L.W. Gathuka), kato.tomohiro.87v@st.kyoto-u.ac.jp (T. Kato), takai.atsushi.2s@kyoto-u.ac.jp (A. Takai), gfloresb@utec.edu.pe (G. Flores), inui@civil.eng.osaka-u.ac.jp (T. Inui), katsumi.takeshi.6v@kyoto-u.ac.jp (T. Katsumi).

<https://doi.org/10.1016/j.sandf.2021.05.007>

0038-0806/© 2021 Production and hosting by Elsevier B.V. on behalf of The Japanese Geotechnical Society.

This is an open access article under the CC BY-NC-ND license (<http://creativecommons.org/licenses/by-nc-nd/4.0/>).

or hindered due to several geotechnical and geoenvironmental concerns. Natural contamination has been one of the issues actively discussed in Japan, particularly since 2010. In 2010, the Soil Contamination Countermeasures Law (SCCL), a national law related to soil contamination, was revised to cover natural (geogenic) contamination. Naturally derived toxic metals and metalloids are widely distributed throughout the country in marine clay layers, claystone layers, thermally altered rocks, etc., due to such geological processes as active geothermal phenomena (e.g., Ujiié-Mikoshihba et al., 2006; Tabein et al., 2018). The way to properly manage these naturally contaminated soils and rocks after excavating them has become an important consideration since it involves the risk of the leaching of unacceptable concentrations of toxic metals and metalloids (e.g., Tabein et al., 2018; Ito and Katsumi, 2020). However, serious environmental risks may not be anticipated because the concentrations are only slightly higher or a few times higher than the regulatory standards. Therefore, utilising the soils and rocks under the proper contaminant control conditions, rather than simply disposing them, is highly recommended (Katsumi, 2015). Unfortunately, there are no well-established methods or countermeasures for utilising these soils and rocks, which would realise cost-effectiveness and environmental safety (Ministry of Land, Infrastructure and Transport, 2010).

Attempts have been made at many construction sites to utilise naturally contaminated soils and rocks while implementing countermeasures to ensure environmental safety. Encapsulation using geomembranes and compaction to minimise the infiltration is widely applied as a countermeasure. However, considering the leaching load and the nature of the soils and rocks of concern, it is desirable to implement more low-cost, yet effective, countermeasures. Recently, the attenuation layer method has attracted attention; it is based on a different concept from these other methods (e.g., Tatsuhara et al., 2012; 2015; Nozaki et al., 2013a; Tabein et al., 2018). As shown in Fig. 1, the attenuation layer method involves the installation of an attenuation layer beneath the soils or rocks of concern. The typical attenuation layer material is non-contaminated soil mixed with a stabilising agent with attenuation/sorption capacity. The attenuation layer should function to prevent (or reduce to acceptable levels) the chemicals of concern

infiltrating the ground due to the attenuation capacity. Several benefits exist for this method. One benefit is that stable earthen structures can be constructed in the simple and traditional manner of earthen works. However, several issues remain to be solved in terms of enhancing the attenuation layer method's reliability and widening the scope of its applications.

Evaluating the attenuation performance of the layer material against the target chemicals is an important issue. Based on this need for evaluation, several studies have been undertaken to investigate the attenuation performance of possible layer materials against the chemicals of concern (e.g., Tatsuhara et al., 2012; Nozaki et al., 2013b; Tabein et al., 2014, 2018; Mo et al., 2020). Several important concerns and questions need to be solved when evaluating the attenuation performance. One is how acidic leachate might diminish the layer material's attenuation performance. Several types of rocks and soils contain sulphide minerals (e.g., pyrite). Exposing them to air oxidises the minerals to produce sulphuric acid (Tabelin et al., 2012; Inui et al., 2013; Paikaray, 2015). Whether or not the material's attenuation performance will diminish due to the acidity needs to be clarified before using the material in the attenuation layer. If the layer material's attenuation performance is diminished, the acid drainage loaded with toxic metals and metalloids will contaminate the receiving environment. However, very few studies have evaluated the attenuation performance of layer materials against acidic leachate. Therefore, to increase the opportunities and reliability of applying the attenuation layer method, a better understanding of the effect of acidic leachates on the attenuation performance of the layer materials is required.

The present work evaluates the attenuation performance of soil amended with a calcium-magnesium (Ca-Mg) composite against arsenic in solutions of pH 2, 4 and 6. The Ca-Mg composite is manufactured mainly from calcined natural minerals. Due to calcinating these minerals, they usually tend to exhibit stronger compatibility with several kinds of chemicals (e.g., Itaya and Kuninishi, 2019; Salameh et al., 2015). A previous study (Mo et al., 2020) attempted to mix decomposed granite soil with a decent amount of stabilising agent to attenuate the arsenic and to show it as feasible. Like the previous study, an agent content of 5% was considered for amending the soil. However, the present work uses a granular Ca-Mg composite

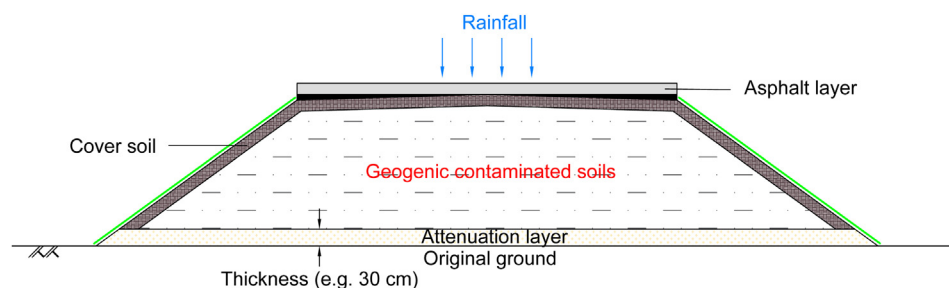

Fig. 1. Schematic of conventional design for attenuation layer method.

with particles smaller than 2 mm, not the Ca-Mg composite with particles smaller than 0.075 mm used in the previous study. Therefore, a lower attenuation capacity should be expected due to a smaller specific surface area. Batch tests and column tests using a flexible-wall permeameter were performed to evaluate the attenuation performance. Arsenic was selected as the target contaminant since it is one of the important chemicals in geogenic contamination. Many researchers (e.g., Takahashi et al., 2011; Inui et al., 2013; Li et al., 2018) have found that during the post-excavation leaching of contaminated materials, this toxic element is leached in concentrations that exceed the acceptable limits in Japan.

2. Materials and methodologies

2.1. Materials

Decomposed granite soil, which is a commercially available soil, was collected in Kyoto and used for the tests after being oven-dried for 1 day and sieved with a 2-mm opening screen. Its particle size distribution, shown in Fig. 2, was determined as per JIS A 1204 (2009) with particle density $\rho_s = 2.67 \text{ g/cm}^3$, as per JIS A 1202 (2009), and compaction characteristics as per the A-a method of JIS A 1210 (2009). The sieved soil was classified as sand with fine fractions (S-F), based on the guidelines for classifying geomaterials standardised in JGS 0051 (2015). For the chemical analysis, the soil was manually ground to $<75 \mu\text{m}$ using an agate mortar and pestle and then analysed by X-ray fluorescence (XRF) (EDX-720, Shimadzu). Table 1 summarises the physical and chemical properties of the sieved soil.

Ca-Mg composite, manufactured by Sumitomo Osaka Cement Co., Ltd., was the stabilising agent. Fig. 2 shows its particle size distribution and appearance. Table 2 summarises its chemical composition, quantitated as per JIS R 9011 (2006), in terms of the oxidation minerals. According to the manufacturer, it mainly comprises calcium (as CaCO_3) with a content of 35.6%. The magnesium (as MgCO_3 and MgO) content is 19.4%. It also contains trace

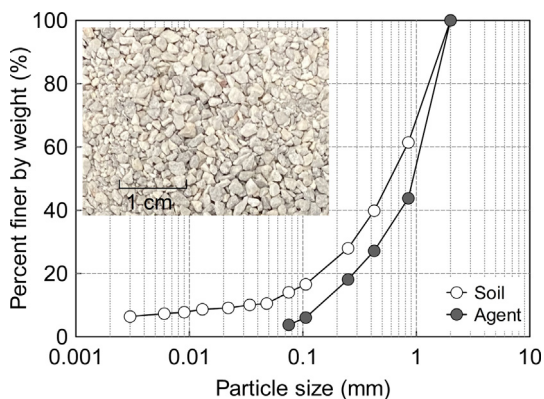

Fig. 2. Particle size distribution of sieved soil and Ca-Mg composite. The photo shows the appearance of the agent.

Table 1
Physical and chemical properties of the soil.

Parameter	Value
Particle density	2.67 g/cm^3
Particle size distribution	
Sand fraction [0.075–2 mm]	85.9%
Silt fraction [0.005–0.075 mm]	7.7%
Clay fraction [$<0.005 \text{ mm}$]	6.4%
Chemical composition	
SiO_2	45.5%
Fe_2O_3	20.6%
CaO	6.6%
Al_2O_3	16.9%
Others	10.4%

Table 2
Chemical properties of the Ca-Mg composite (unit: wt.%).

Ig. loss	CaO	MgO	SO_3	Fe_2O_3	SiO_2	Al_2O_3	P_2O_5
33.5	35.6	19.4	3.98	3.73	1.52	0.068	0.035

Source: Data from The Society of Materials Science, Japan (JSMS, 2014).

amounts of iron (as FeSO_4). Further, the high ignition loss of 33.5% is attributed to the decarbonation of CaCO_3 . Its specific surface area, $\text{SSA} = 3.7 \text{ m}^2/\text{g}$, was determined using the nitrogen adsorption Brunauer-Emmet-Teller (BET) method.

The test specimens had one of two agent contents (0 or 5%). The agent contents of 0 and 5% corresponded to 0 g and 50 g of the stabilising agent per kg of dry soil, respectively. To prepare the test specimens, firstly, the dry soil was poured into a steel bowl. An appropriate amount of agent was added to the soil when preparing the 5% case. After that, distilled water was added using the appropriate amount necessary to achieve the optimum water contents of 10.1 and 11.0% when using 0 and 5% agent contents, respectively. The particle density of the amended soil was also 2.67 g/cm^3 based on JIS R 5201 (2015). Mixing was completed using a soil mixer. During the mixing, the machine was temporarily stopped from time to time to scrape the sides and bottom of the bowl. These steps were taken for the purpose of preparing homogeneous specimens.

2.2. Experiments

2.2.1. Batch shaking tests

Batch tests were used to evaluate the arsenic attenuation performance of the soil-agent mixtures at a liquid to solid (L/S) ratio of 10. Changes in the attenuation performance were quantified using sorption isotherms obtained from the tests. Five different concentrations of arsenic were used: 0.1, 0.5, 1, 5 and 10 mg/L. For each concentration, several solutions of pH 2, 4 and 6 were prepared. The solutions were prepared using As in the form of sodium arsenite (NaAsO_2), whereby accurate amounts of NaAsO_2 salts were dissolved in distilled water to produce stock solutions

of 1000 mg/L As, and then appropriate dilutions were completed. Sulphuric acid (H_2SO_4) was added dropwise to the solutions to adjust their pH levels.

The test specimens were added to the solutions in 1-L capped plastic bottles to achieve L/S 10. Then, horizontal shaking of the specimen bottles was conducted at 150 rpm for 24 h using a mechanical shaker (TS-10, TAI-TEC) at a room temperature of $\sim 20^\circ C$. Later, the specimen bottles were removed from the machine. Their contents were centrifuged at 3000 rpm for 10 min, which helped separate the solid particles from the solution. Table 3 summarises the conditions for the batch tests.

2.2.2. Column percolation tests

The column tests were completed with a flexible-wall permeameters (Fig. 3). The tests were used to monitor the arsenic concentrations at several L/S ratios, including much smaller ratios than those in the batch tests. Smaller ratios can better represent the in-field interactions of the leachates with the materials. In addition, the tests were conducted under saturated conditions, which helped prevent preferential flow occurrences. While a better interpretation, in view of practice, should be obtained by unsaturated percolation, straightforward interpretations of the test results are expected under saturated conditions.

Each test specimen was compacted in a steel mould, 6 cm in inner diameter and 7 cm in height, in three layers of equal height and with a degree of compaction of 95%. The compacted specimen was saturated for at least 48 h in a vacuum deaerator. After that, it was removed from the steel mould, whilst not causing it any physical damage, and set on the flexible-wall permeameter with its upper and lower surfaces confined by acrylic pedestals 6 cm in diameter. Filter papers and geotextiles were used to separate the top and bottom surfaces of the specimen from the pedestals in order to prevent the clogging of the channels by the fine soil particles. To prevent air from intruding into the specimen during the test, the filter papers and geotextiles were deaerated beforehand in a glass beaker filled with distilled water. A latex membrane smeared with silicone grease on its lateral face was used to confine the sides of the specimen along with the top and base pedestals for the prevention of side-wall leakage. Two O-rings were employed at the top and bottom pedestals to seal the specimen. After assembling the apparatus and saturating all the channels with distilled water, the cell pressure was set to 50 kPa.

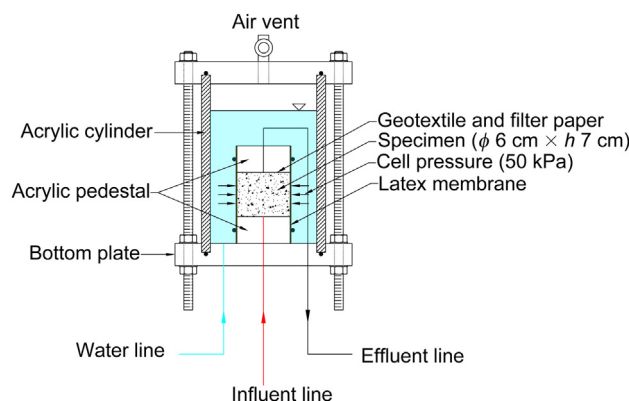

Fig. 3. Schematic of flexible-wall permeameter used for column tests.

Arsenic solutions of pH 2, 4 and 6 were prepared and used in the tests after deairing them for 24 h. The arsenic concentration in the solutions was 0.1 mg/L. Several studies have shown that leaching concentrations of arsenic are often slightly higher than the acceptable limit of 0.01 mg/L (e.g., 2–3 times higher). In some cases, however, the concentrations can be much higher than the limit (e.g., 10 times higher). For each case listed in Table 4, and with the temperature of the room set at $\sim 20^\circ C$, the deaired solution was continuously percolated as the influent in an up-flow direction using a peristaltic pump at a flow rate of 4.5 mL/h (equivalent to the Darcian velocity of 4 cm/d). The tests were terminated if they satisfied one of the following two conditions: (1) the arsenic concentrations measured in the effluents exceeded 0.01 mg/L, which is the acceptable limit in Japan, or (2) $\sim L/S$ 50 was attained. This ratio is equivalent to percolating ~ 330 pore volumes of flow into the specimens. The pore volumes of flow (PVF) was calculated by dividing the cumulative volume of the effluent collected during the test with the volume of the voids in the specimen. Effluents were periodically collected in glass bottles connected to Smart Bag PA (GL Sciences Inc.) to avoid any contact with the environment.

2.2.3. Chemical analyses

In the above experiments, the solutions collected were filtered using a membrane filter (Millex-HV, Millipore) with a particle size retention of 0.45 μm . The pH, electrical conductivity (EC) and redox potential (E_h) of the filtrate were measured. The arsenic concentrations were measured by an atomic absorption spectrophotometer (AAS) (AA-

Table 3
Conditions for the batch shaking tests.

Solvent	NaAsO ₂ solution (conc.: 0.1, 0.5, 1, 5 and 10 mg/L)
Solvent pH	pH 2, 4 and 6 (adjusted with H ₂ SO ₄)
Agent content	0, 5% (=50 g/kg-soil)
Specimen mass	>50 g
Liquid to solid ratio	10 L/kg
Mixing	Horizontal shaking at 150 rpm
Shaking time	24 h

Table 4
Conditions for the column percolation tests.

Case No.	1	2	3	4	5
Agent content (%)	0	0	0	5	5
Influent pH	6	4	2	6	2
Dry density, ρ_d (g/cm ³)	1.91	1.91	1.92	1.89	1.88
Volume of voids, V_v (cm ³)	57.1	56.8	56.6	58.1	58.5

6800, Shimadzu). The concentrations of several cations (Al, Ca, Fe, K, Mg and Na) were measured by an inductively coupled plasma optical emission spectrometer (ICP-OES) (ICP-OES 710, Agilent Technologies).

2.3. Solute transport analysis

The data observed in the column tests was fitted using the following advection-dispersion equation:

$$R \frac{\partial C}{\partial t} = D \frac{\partial^2 C}{\partial x^2} - v_s \frac{\partial C}{\partial x} \quad (1)$$

where R is the retardation factor. Retardation phenomena result from the chemical reactions between the soil, agent and water in the column tests. Therefore, R can express the chemical reactions (e.g., sorption effect). Since the arsenic concentrations applied in the column tests were relatively low ($As = 0.1$ mg/L), the sorption behaviour of the materials might be assumed as linear sorption behaviour. Therefore, applying linear sorption was considered reasonable for interpreting the column test results. For linear sorption, $R = 1 + \rho_d K_d/n$, where K_d (cm³/g) is the partition coefficient and n is the porosity of the specimen. It is noted that under these assumptions, the individual chemical reactions occurring in the materials to buffer the metal concentrations (e.g., precipitation reactions) are not independently clarified or considered.

Assuming the initial and ‘constant concentration’ boundary conditions as

$$C|_{x \geq 0, t=0} = 0, C|_{x=0, t \geq 0} = C_0, C|_{x=L, t \geq 0} = 0 \quad (2)$$

the solution to Eq. (1) for these conditions has been given by Ogata and Banks (1961) as

$$C = C_0/2 \left\{ \operatorname{erfc} \left[\frac{(RL - v_s t)/(4RDt)^{1/2}}{1} \right] + \exp(v_s L/D) \operatorname{erfc} \left[\frac{(RL + v_s t)/(4RDt)^{1/2}}{1} \right] \right\} \quad (3)$$

where C_0 (mg/L) is the initial solute concentration, C (mg/L) is the solute concentration at x distance from the source at time t , L (cm) is the column length, v_s (cm/s) is the average seepage velocity, $D [= v_s \alpha_L + D_m]$, where α_L (cm) is the longitudinal dispersivity which is roughly approximated as $0.1L$ (Gelhar et al., 1992) and D_m (cm²/s) is the effective diffusion coefficient which for As is estimated to be 0.905×10^{-5} cm²/s (Lide, 2001)] is the longitudinal dispersion coefficient, and erfc is the complementary error function.

According to van Genuchten and Parker (1984), Eq. (3) can be non-dimensionalised by substituting the column Peclet number ($Pe = v_s L/D$) and PVF ($T = v_s t/L$) as

$$C = C_0/2 \left\{ \operatorname{erfc} \left[(Pe/4RT)^{1/2} (R - T) \right] + \exp(Pe) \operatorname{erfc} \left[(Pe/4RT)^{1/2} (R + T) \right] \right\} \quad (4)$$

Considering the flow conditions applied in the column percolation tests (refer to Section 2.2), $D = 1.1 \times 10^{-4}$ cm²/s and $Pe = 9.39$. Therefore, the advection process will play the dominant role in the solute transport phenomena.

The breakthrough curves obtained using Eq. (4) were shifted so that the initial rise in the concentrations of As coincided with the experimental ones. From the various trials, the most representative R was the one for which the residual sum of the squares (SSE) becomes minimum.

$$SSE = \sum_{i=1}^n (C_i - C_i')^2 \quad (5)$$

where C_i is the experiment data series and C_i' is the predicted data series.

3. Results

3.1. Batch shaking tests

3.1.1. Sorption isotherms

Fig. 4 shows the non-linear relationships between the amount of As retained, S (mg/g), and the concentrations of As remaining in the solutions, C (mg/L), which were fitted using the following empirical Freundlich isotherm:

$$S = KC^N \quad (6)$$

where K (cm³/g) and N are Freundlich parameters.

This kind of S - C relationship generally suggests that a solid material has a finite capacity to buffer metal concentrations (Devulpalli and Reddy, 1996). In contrast to the 0% cases, the 5% cases exhibit a higher arsenic attenuation performance. A larger inclination of the sorption isotherms shows a higher attenuation performance. However, the differences may not be evident for the relatively low arsenic concentrations. Freundlich parameter K was used as an index for quantifying the attenuation performance of the materials. For the 0% cases, K was 12.3, 12.0 and 11.8 cm³/g when the contacting solution was pH 6, 4 and 2, respectively. Likewise, for the 5% cases, K was estimated to be 24.9, 23.0 and 17.0 cm³/g, respectively. Table 5

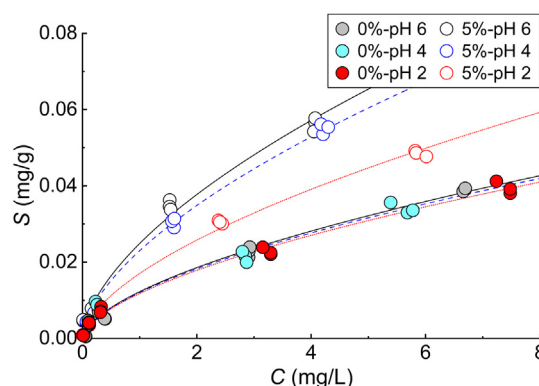

Fig. 4. Freundlich sorption isotherms for 0 and 5% cases.

summarises the obtained K values. The K for the 5% cases was two times higher than the K for the 0% cases, except for the condition with pH 2, where it was 40% higher. Therefore, using an agent content of 5% is enough to bring about substantial improvements in the soil's attenuation performance. Further, the K for the 5% case decreases by ~30% when the conditions change from pH 6 to pH 2.

3.1.2. Changes in solution chemistry

Fig. 5 shows the post-shaking chemistry of the contacting solutions in terms of pH, E_h , and concentrations of Ca^{2+} and Mg^{2+} . Fig. 5(a) shows that, for the 0% cases, the solutions were alkaline with pH ~ 8 under the initial pH conditions of 6 and 4. However, they remained acidic with pH ~ 4.5 under an initial pH condition of 2. For the 5% cases, the solutions were strongly alkaline with pH = 9–10 under the initial pH condition of 6 or 4. Under an initial pH condition of 2, the solutions were circumneutral, defined by Nordstrom (2011) as pH = 6–8. Overall, the pH for the 5% cases was higher than those for the 0% cases by at least 1 pH unit. Since soil without any agent exhibits a low pH buffering capacity, it might be inappropriate to use the soil to buffer the acid in strongly acidic leachates. The results suggest that using an agent content of 5% can substantially improve the soil's pH buffering capacity. Moreover, the final pH will depend on the initial pH and the material's buffering capacity.

Chemical forms of arsenic, as well other water-soluble chemicals, are influenced by the pH and E_h of the water. From Fig. 5(b), the solutions are under oxidising conditions since $E_h = 200$ –600 mV. Using an E_h -pH diagram for the As-O-H systems (Lu and Zhu, 2011), it was identified that when the pH = 7–11, the dissolved As was generally present as a negatively charged HAsO_4^{2-} oxyanion, and when pH = 2–7, it was generally present as a negatively charged H_2AsO_4^- oxyanion. These results suggest that the As applied as NaAsO_2 [or As(III)] was oxidised to As(V). Therefore, two attenuation mechanisms might occur, the first being the electrostatic attraction of the oxyanions on the variable charge of clay according to the pH (e.g., Bolan et al., 1999) and the second being the precipitation reactions with the cations (e.g., Ca and Mg) released from the soil or the agent.

In contrast to other cations, the concentrations of Ca^{2+} and Mg^{2+} were much higher, and their values were in the mg/L levels. In addition, their concentrations increased as the initial pH was lowered from 6 to 2 [Fig. 5(c) and (d)]. Since their concentrations were notably the same for

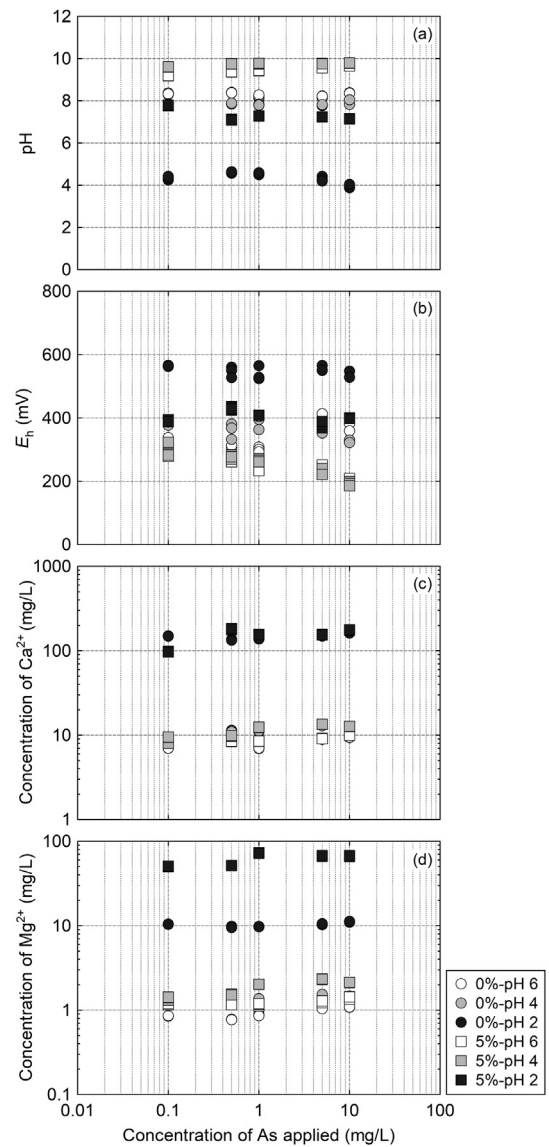

Fig. 5. Post-shaking results of contacting solutions' chemistry.

the different concentrations of applied As, these increasing trends suggest that the cations were being exchanged for H^+ (e.g., McBride, 1994) and/or the carbonate minerals in the Ca-Mg composite were being dissolved and precipitated (e.g., Stumm and Morgan, 2012). Higher concentrations of Ca^{2+} than Mg^{2+} are most likely because: (1) there was a greater amount of the Ca-based chemicals than the Mg-based chemicals in the materials, and/or (2) there was order reactivity of the carbonate minerals in the Ca-Mg composite; that is, calcite > dolomite > Mg ankerite (e.g., Blowes and Ptacek, 1994).

3.2. Column percolation tests

3.2.1. Breakthrough curves

Fig. 6 shows the breakthrough curves from the column tests. In this figure, only the data for the concentrations not exceeding 0.025 mg/L As were plotted in order to make

Table 5
Freundlich isotherm parameters.

	0%			5%		
	K (cm^3/g)	N	R^2	K (cm^3/g)	N	R^2
pH 2	11.8		0.99	17.0		0.99
pH 4	12.0	0.6	0.99	23.0	0.6	0.98
pH 6	12.3		0.99	24.9		0.99

it easy to recognise the differences among the several cases. For the 0%-pH 2 case, the data for $As > 0.025$ mg/L is not given in the figure, but it was included in other results. The breakthrough concentration was taken as the maximum allowable leaching concentration in Japan. That is, $As = 0.01$ mg/L. Fig. 6(a) shows that, for the 0% cases, the breakthrough occurs after $\sim L/S$ 20 if the influent pH is 6 or 4. A much earlier breakthrough occurs when using a strongly acidic influent ($=pH$ 2), namely, before L/S 10.

For the 5% cases, only the influents of pH 6 and 2 were used. It was assumed that no obvious changes in the attenuation of As should occur when the amended soil is percolated with influents of $pH = 6-4$. Fig. 6(b) shows that, until the tests' termination at $\sim L/S$ 50, the concentrations in the effluents did not exceed 5% of the concentration of the applied As ($As = 0.1$ mg/L) during percolation with the influent of pH 6, and even pH 2. More importantly, these concentrations did not exceed the acceptable limit, $As = 0.01$ mg/L. A delayed breakthrough is very desirable in the field. Stronger buffering of the metal concentrations and longer reactivity under different leachate pH levels can be realised when the soil is amended with the agent, even if the agent content of 5% is employed.

Table 6 summarises the solute transport parameters for the 0% cases obtained by following the steps and discussed

previously in Section 2.3. The predicted breakthrough curves shown in Fig. 7 were obtained using these parameters. It was not possible to complete the analysis for the 5% cases because the initial rise in the concentration of As could not be established from the available experimental data at that time. The K_d values were calculated from the obtained R . They were estimated as 38, 36 and 13 cm^3/g when the influent was pH 6, 4 and 2, respectively. The results suggest that no apparent changes in this soil's attenuation performance should occur when the leachate pH is in the range of 6–4. However, when the leachate pH is below 4, its arsenic attenuation will be adversely affected. If it is a strongly acidic leachate ($=pH$ 2), the K_d values can decrease by 30% or even more.

3.2.2. Trends in effluent chemistry

Fig. 8(a) and (b) show the trends in the effluent pH (pH_{out}) during the percolation of the specimens with chemical solutions of pH 6 or 2, respectively. For the 0% cases, the effluents are found to be slightly alkaline with the pH of ~ 7.6 . However, pH_{out} eventually tends to decrease back to pH_{in} with the increasing number of PVFs. This decrease in pH_{out} is seen to be gradual during the percolation with the pH 6 influent [Fig. 8(a)], and then accelerates during the percolation with the pH 2 influent [Fig. 8(b)]. Fig. 8(b) shows that, during the percolation of the 0% case with the pH 2 influent, pH_{out} drastically decreases from 7.6 to 2.5 after L/S 3. This shift in pH coincides with the point at which the concentrations of leached Ca^{2+} start to decline, thereby suggesting a possible relationship.

For the 5% cases, the pH_{out} is usually found to be at least 1 pH unit higher than for the 0% cases. Furthermore, the decrease in pH_{out} is seen to be gradual during the percolation with the pH 6 influent [Fig. 8(a)], and then accelerates during the percolation with the pH 2 influent [Fig. 8(b)]. Fig. 8(b) shows that, during the percolation of the 5% case with the pH 2 influent, pH_{out} decreases towards pH_{in} with further percolation after L/S 7. This shift in pH coincides with the point at which the concentrations of leached Mg^{2+} start to decline, thereby suggesting a possible relationship. Taking pH 7.6 as the baseline, which corresponds to the average pH_{out} of the 0% cases before the reduction, it was estimated that for the 5% cases, it would take $\sim L/S$ 30 for the pH_{out} to drop below this value. The results confirm that using an agent content of 5% for amending the soil can improve its pH buffering capacity. Moreover, the exhaustion of the amended soil's pH buffering capacity will be prolonged even when percolated with strongly acidic leachates ($=pH$ 2).

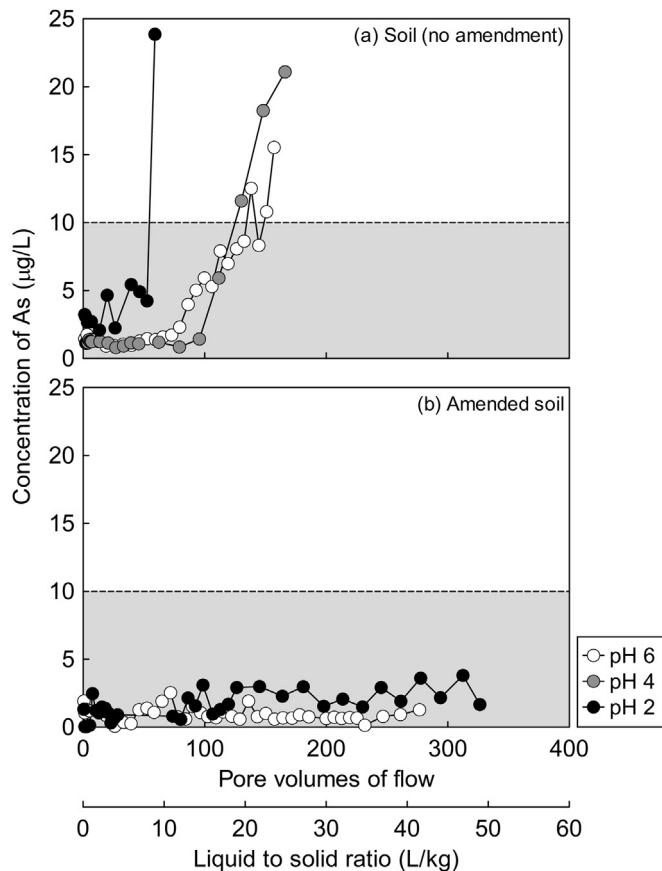

Fig. 6. Concentrations of arsenic in effluents during column tests for 0 and 5% cases. The grey shaded area denotes the acceptable concentrations in Japan.

Table 6

Solute transport parameters (agent content: 0%).

Case ID	Influent pH	R	K_d (cm^3/g)	D (cm^2/s)	Pe
1	6	264	37.8	1.1×10^{-4}	9.39
2	4	250	35.7	1.1×10^{-4}	9.39
3	2	90	12.8	1.1×10^{-4}	9.39

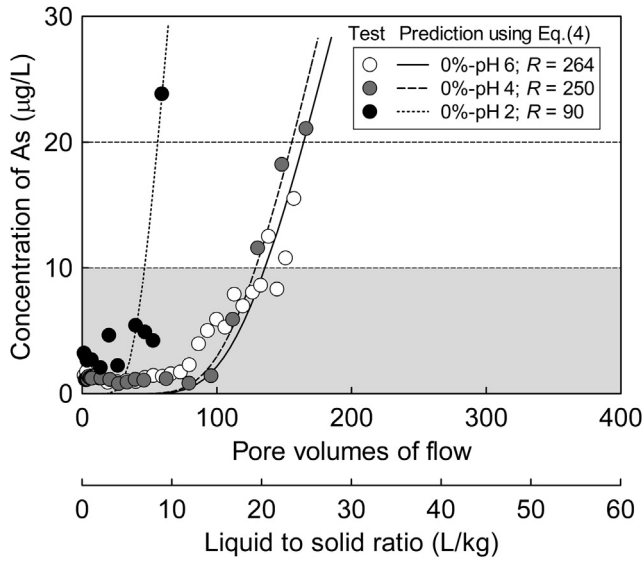

Fig. 7. Modelled breakthrough curves from column tests of 0% cases. The grey shaded area denotes the acceptable concentrations in Japan.

Fig. 8(c) shows that the effluent EC (EC_{out}) decreases towards the influent EC (EC_{in}) with the increasing percolation volume, while Fig. 8(d) shows that the EC_{out} increases towards EC_{in} with the increasing percolation volume. Since $EC_{out} \neq EC_{in}$ implies that a chemical equilibrium had not been reached.

Fig. 9 shows the general trend of the pH ratio (pH_{out}/pH_{in}) and the EC ratio (EC_{out}/EC_{in}) with the increasing number of PVFs. According to Shackelford et al. (2010), when pH_{in} or EC_{in} is lower than the initial pH or EC of the specimen-pore water, i.e., pH_s or EC_s , these ratios will initially be greater than unity. Eventually, they should decrease towards unity with the increasing number of PVFs. Likewise, when the pH_{in} or EC_{in} is higher than the pH_s or EC_s , these ratios will initially be lower than unity, but will eventually increase towards unity with the increasing number of PVFs. The results suggest that the rate of decrease in pH_{out}/pH_{in} is dependent on two aspects, i.e., the presence of the Ca-Mg composite and acidity. The decrease in pH_{out}/pH_{in} will be accelerated due to the absence of an agent and/or very low pH.

Fig. 10 shows the trends in the concentrations of Ca^{2+} and Mg^{2+} in the effluents. As shown in Fig. 10(a) and (c), it is most likely that the Ca-Mg composite suppresses the leaching of Ca^{2+} , while it promotes the leaching of Mg^{2+} during the percolation of the 5% case with the pH 6 influent. Fig. 10(b) and (d) show that, for both the 0 and 5% cases, significantly higher concentrations of Ca^{2+} and Mg^{2+} were leached from the materials because of using the pH 2 influent. Comparing the leaching trends of Ca^{2+} and Mg^{2+} in the figure, they are similar for the same pH_{in} . Furthermore, the concentrations of Ca^{2+} are higher than those of Mg^{2+} , which is similar to the batch test results.

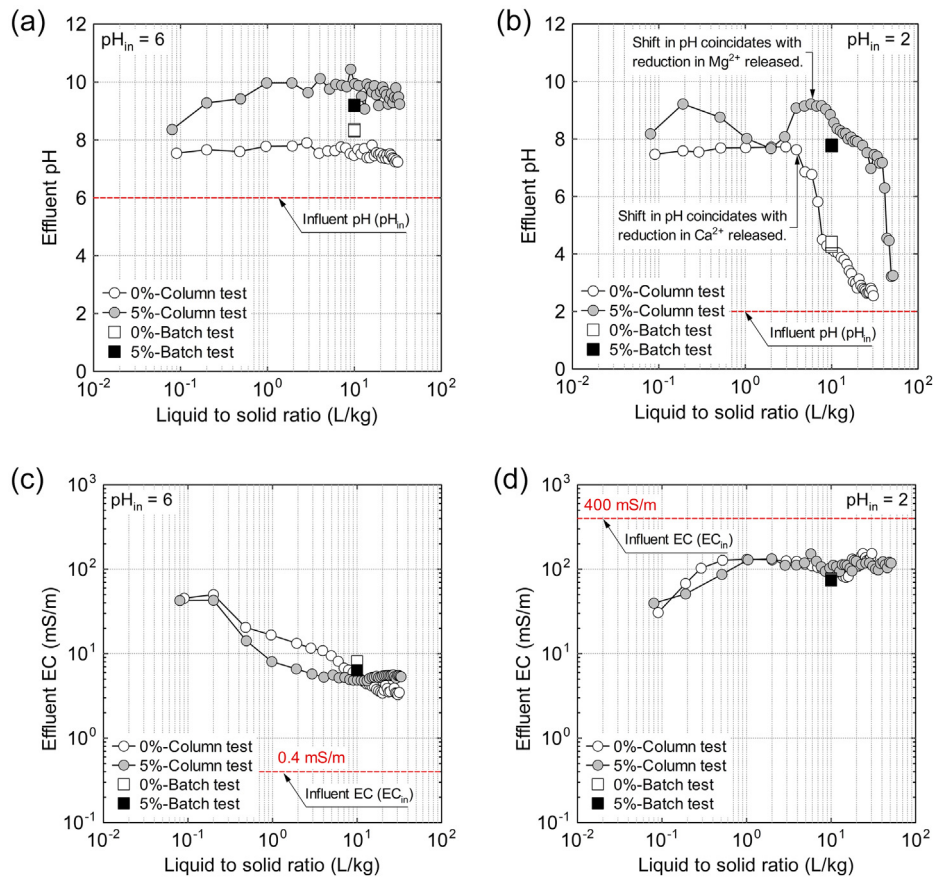

Fig. 8. Trends in pH and electrical conductivity of effluents under conditions of pH 2 or 6.

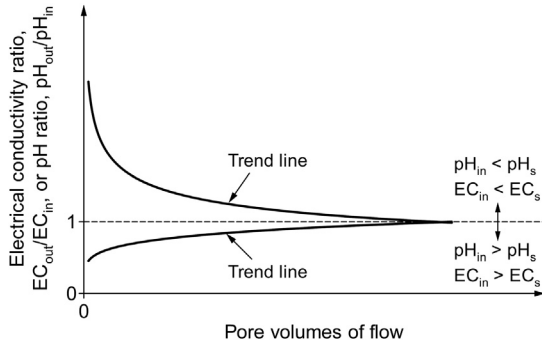

Fig. 9. Schematic trend in electrical conductivity and pH ratios with increasing number of PVFs (after Shackelford et al., 2010).

3.2.3. Comparison of data from two laboratory tests

The chemistry of the solutions collected from the two laboratory tests at L/S 10 is compared here. The findings from the batch tests were closely reflected in the column tests (refer to Figs. 8 and 10). However, the actual data from the batch tests sometimes could not be truly reflected in the column tests. For instance, in some cases, the pH was 1 unit lower in the batch tests (refer to Fig. 8). According to Tatsuhara et al. (2012), these differences in the results between the batch tests and the column tests can be attributed to the constant ‘renewal’ of the pore water in the latter tests that probably resulted in more localised disequilib-

rium conditions. While the batch test may not reflect the actual interactions of the materials with leachates, the test remains useful for showing the differences in the chemical compatibility of the materials.

4. Discussion

4.1. Expected attenuation and pH buffering mechanisms

4.1.1. Speciation of dissolved As

Fig. 11 shows the chemistry of the effluents from the column tests in terms of E_h , pH and concentrations of As. Here, the effluents collected after 1 PVF are considered. Using an E_h -pH diagram for the As-O-H systems (Lu and Zhu, 2011), it is recognised that the dissolved As in the effluents will most likely exist as a negatively charged HAsO_4^{2-} and/or H_2AsO_4^- oxyanion according to their pH. The As species and their associated compounds have less mobility and toxicity, and are stable over a wide pH range (Bothe and Brown, 1999).

4.1.2. Expected attenuation and pH buffering mechanisms

Fig. 12 shows the chemistry of the effluents from the column percolation tests in terms of E_h , pH and concentrations of As, Ca^{2+} and Mg^{2+} . Here, the effluents collected after 1 PVF are considered. This figure was used to deduce

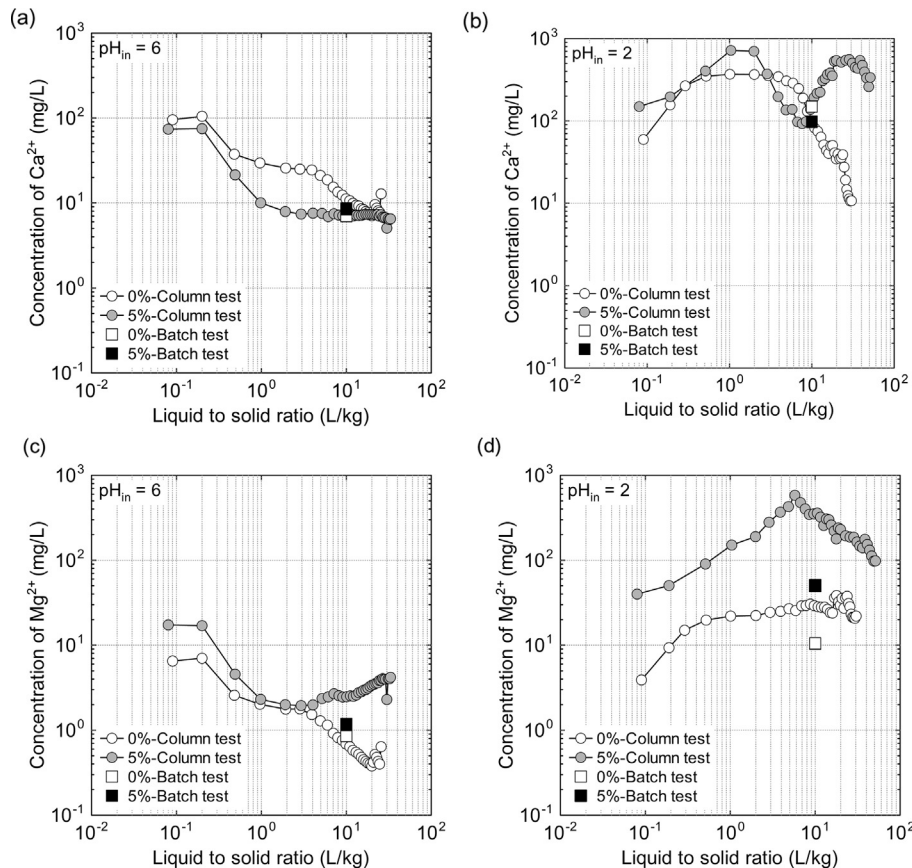

Fig. 10. Trends in concentrations of Ca^{2+} and Mg^{2+} in effluents under conditions of pH 2 or 6.

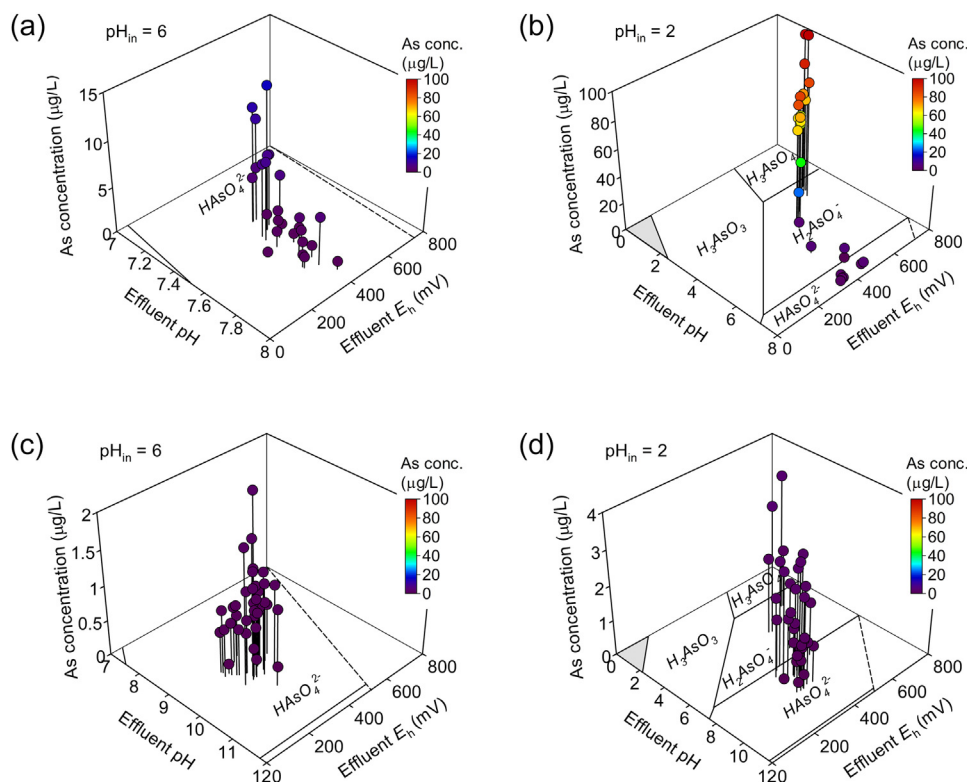

Fig. 11. Chemistry of effluents in terms of their E_h , pH and concentration of As. The figures at the top are for the soil (no amendment), while the figures at the bottom are for the amended soil. The E_h -pH diagram is for the As-O-H system (after Lu and Zhu, 2011). The grey shaded area denotes the solid phase.

the expected attenuation mechanisms when using the amended soil as the attenuation layer material. As far as attenuation mechanisms by the soil material are concerned, the attraction of As on the surface of the soil particles and the co-precipitation between Ca^{2+} and As might be the mechanisms, while attenuation mechanisms by the Ca-Mg composite are expected to be mainly related to the precipitation of Ca-As. These mechanisms are discussed here.

Considering that the soil used here contains substantial amounts of Fe and Al-based chemicals (refer to Table 1), it is most likely carrying variable charges (Bolan et al., 1999). These variable charges will change according to the pH. When the soil particles have net positively charged surfaces, they will attract these negatively charged oxyanions. As the pH of the pore water changes, so will the net surface charge of the soil particles. These changes in the surface charge of the soil particles might contribute to the reduced buffering of the metal concentrations.

In addition, the calcium ions released from the soil are expected to react with the As in the solution to generate low solubility substances such as CaHAsO_3 . McBride (1994) indicated that this mechanism relies on the concentrations of cations released from the soil material. Fig. 12 (a) and (b) support this deduction, whereby the concentrations of As in the effluents are seen to increase exponentially with the decreasing concentrations of Ca^{2+} leached from this soil material. Moreover, the leaching requirement for this cation to reduce the concentrations to below the

acceptable limits is much higher when the leachate is strongly acidic (e.g., pH 2).

As far as attenuation mechanisms by the Ca-Mg composite are concerned, it is expected to be mainly related to the precipitation reactions and essentially from the formation of oxides, hydroxides and/or carbonate phases (e.g., McNeill and Edwards, 1997; Moon et al., 2004; Salameh et al., 2015). This deduction was supported by Itaya et al. (2013). According to the authors (Itaya et al., 2013), low-solubility Ca-As, such as $\text{CaHAsO}_4(\text{H}_2\text{O})$, will be generated during the Ca-Mg composite interactions with the dissolved arsenic.

Therefore, if the attenuation layer material is the amended soil, both the soil and the agent will function to attenuate against the arsenic. Therefore, the above-mentioned mechanisms might occur, but are independent of each other. Furthermore, the magnitude of these mechanisms and how long they will continue to occur will depend on time and the materials. The results suggest that low-solubility Ca-As will be released because of the agent. This mechanism is expected to dominate during the buffering of the metal concentrations. In addition, considering Fig. 12(c) and (d), the arsenic concentrations are the lowest at relatively high pH, but the concentrations tend to increase with decreasing pH. Therefore, the solubility of the Ca-As might depend on the pore water pH (e.g., Bothe and Brown, 1999).

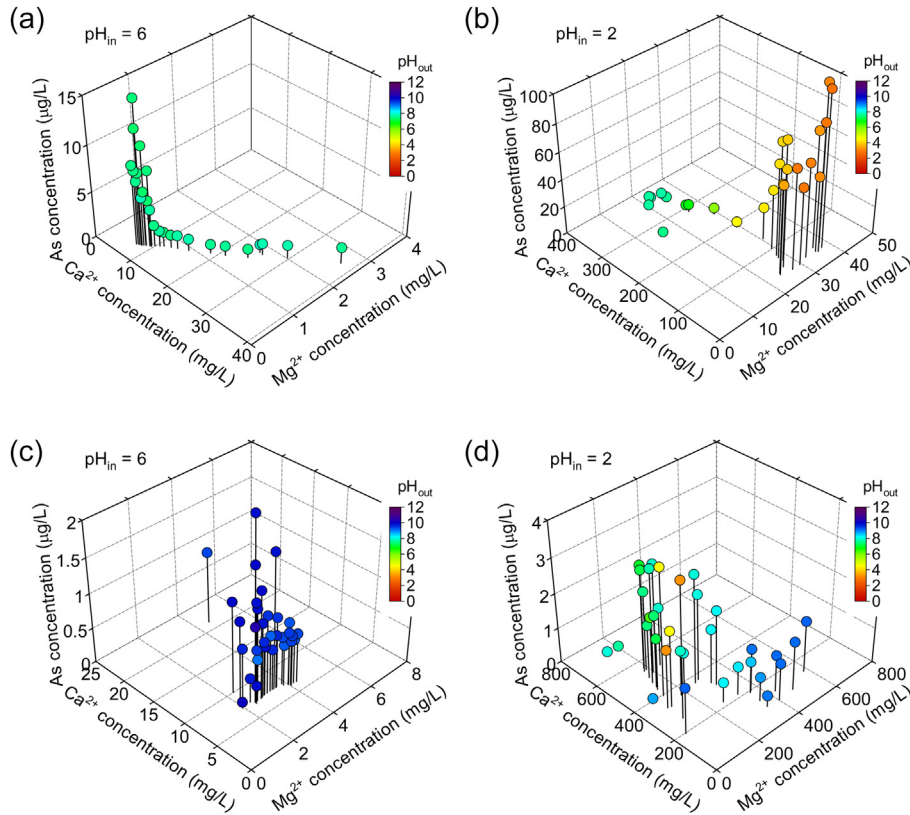

Fig. 12. Chemistry of effluents in terms of their pH and concentrations of As, Ca²⁺ and Mg²⁺. The figures at the top are for the soil (no amendment), while the figures at the bottom are for the amended soil.

The amended soil will buffer the acid due to several independent mechanisms by the soil and the Ca-Mg composite. The soil material is expected to buffer the pH because the major cations are being exchanged for H⁺ (e.g., McBride, 1994). Carbonate mineral buffering is expected because of the Ca-Mg composite (e.g., Stumm and Morgan, 2012). According to the authors (Stumm and Morgan, 2012), when a material contains sufficient calcite and dolomite minerals, the acid drainage can be buffered by the calcite-acid reaction, as shown in Eq. (7), and the dolomite-acid reaction, as shown in Eq. (8).

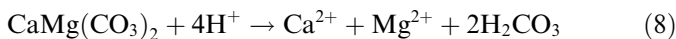
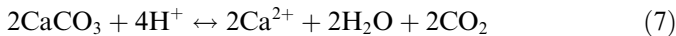

Fig. 13 shows the changes in the concentration ratio of Ca²⁺/Mg²⁺ with the increasing number of PVFs. This figure is used to better understand the pH buffering mechanisms involved when the soil is mixed with the agent. It is recognised that, during permeation using the pH 6 influent, the ratio decreases from 5 towards unity. It is most likely that the calcite-acid buffering reaction might have been dominant at the beginning of permeation. However, with continued permeation, the dolomite-acid buffering mechanism became dominant, while during permeation using the pH 2 influent, the ratio increased from 0.2 to 3 with the increasing number of PVFs. It is most likely that

the dolomite-acid buffering reaction might have been dominant at the beginning of permeation. Later on, both calcite-acid buffering and dolomite-acid buffering mechanisms were dominant. The pH buffering mechanism should co-occur with these two other mechanisms, because of the soil material, but its contributions to the buffering of the pH in the amended soil may not be significant.

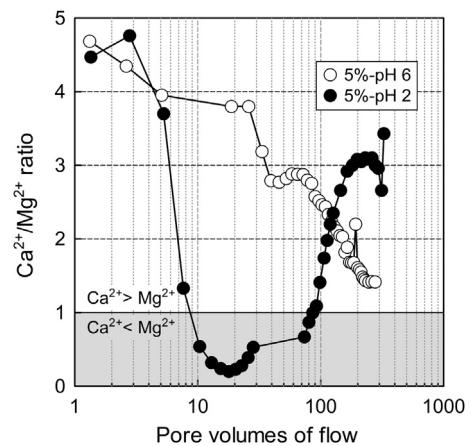

Fig. 13. Trends in Ca²⁺/Mg²⁺ ratio with increasing number of PVFs (agent content: 5%).

4.2. Practical implications

In this present work, the soil's attenuation performance was determined to have improved by at least 40% after the addition of the agent, even if the agent content was 5%. The amended soil will function to assure that the concentrations of As are below the acceptable levels ($As \leq 0.01$ mg/L) for at least a percolation volume of 300 PVF under the given conditions ($As = 0.1$ mg/L). Furthermore, the amended soil will attenuate the arsenic to below the acceptable levels even if the leachate pH is 2, 4 or 6. Therefore, if the amended soil is used as the attenuation layer material, the attenuation layer can be expected to function well in significantly reducing the risk of ground contamination.

The pH buffering capacity of the attenuation layer is considered to be another important mechanism for reducing the risk of ground contamination. Even if the attenuation layer is not capable of attenuating the As, the original ground can be expected to attenuate the As. However, the attenuation capacity of the original ground is dependent on the pH values; the attenuation of As may be reduced under the low pH conditions. The results show that the amended soil will buffer the acid to $pH > 6$. Thus, if the attenuation layer buffers the acid and provides leachate with $pH > 6$, it will assure that the attenuation capacity of the original ground is utilised.

However, this simple evaluation under the assumed conditions might be different under practical conditions. For example, a constant concentration ($As = 0.1$ mg/L) is considered here, but concentrations exceeding this value may sometimes be reported. In such cases, it is necessary to confirm the effectiveness of the materials before the in-field application. In addition, the attenuation layer material is generally unsaturated, and the chemical environments may differ. For instance, the DO concentration is very small for the saturated layer, while it is large for the unsaturated one. Moreover, a preferential flow might exist under the unsaturated conditions, and the attenuation layer would exist under anaerobic conditions if the embankment were high. Further studies are required, while considering the above issues.

5. Conclusions

Batch and column tests, using arsenic solutions of pH 2, 4 or 6, were conducted on a soil-agent mixture to discuss how acidity affects its arsenic attenuation performance. The results support the following conclusions:

1. Soil mixed with an agent exhibits better attenuation performance than soil without an agent. Using Freundlich parameter K as the index, the soil's attenuation performance was determined to have improved by at least 40% after the addition of the agent, even when the agent content was 5%. Further, the amended soil's attenuation performance should be similar if the leachate pH is pH 6–4; it might decrease by up to ~30% for $pH < 4$.

2. The pH buffering capacity of the attenuation layer is considered to be another important mechanism for reducing the risk of ground contamination. The amended soil can buffer the acid to $pH > 6$. Thus, if the attenuation layer buffers the acid and provides the leachate with $pH > 6$, it will assure that the original ground's attenuation capacity is utilised.
3. Both the soil and the agent in the amended soil should contribute to the attenuation of arsenic. However, the attenuation mechanism by the agent should dominate. Therefore, low-solubility Ca-As might be released from the attenuation layer when the amended soil attenuates the arsenic in the leachate.

Declaration of Competing Interest

The authors declare that they have no known competing financial interests or personal relationships that could have appeared to influence the work reported in this paper.

Acknowledgements

The authors would like to express their thanks to Mr Kenji Kuninishi and Mr Shintaro Hayashi (Sumitomo Osaka Cement, Co., Ltd.) for providing the Ca-Mg composite used as the agent in this study. Their appreciation is also extended to Ms Ando L. Rabenarimanitra for her assistance with the experimental works, and to Dr Jialin Mo for his contributions to this research.

References

- Bolan, N.S., Naidu, R., Syers, J.K., Tillman, R.W., 1999. Surface charge and solute interactions in soils. *Adv. Agron.* 67, 87–140. [https://doi.org/10.1016/S0065-2113\(08\)60514-3](https://doi.org/10.1016/S0065-2113(08)60514-3).
- Bothe, J.V., Brown, P.W., 1999. The stabilities of calcium arsenates at $23 \pm 1^\circ\text{C}$. *J. Hazard. Mater.* 69 (2), 197–207. [https://doi.org/10.1016/S0304-3894\(99\)00105-3](https://doi.org/10.1016/S0304-3894(99)00105-3).
- Blowes, D.W., Ptacek, C.J., 1994. Acid neutralization mechanism in inactive mine tailings. In: Jambor, J.L., Blowes, D.W. (Eds.), *Environmental Geochemistry of Sulfide Mine-Waste*, vol. 22. Mineralogical Association of Canada, pp. 272–292.
- Devulpalli, S.S.N., Reddy, K.R., 1996. Effect of non-linear adsorption on contaminant transport through landfill clay liners. In: Kamon, M. (Ed.), *Proceedings of the 2nd International Congress on Environmental Geotechnics*, Osaka, Japan, vol. 1. Balkema, pp. 473–478.
- Gelhar, L.W., Welty, C., Rehfeldt, K.R., 1992. A critical review of data on field-scale dispersion in aquifers. *Water Resour. Res.* 28 (7), 1955–1974. <https://doi.org/10.1029/92WR00607>.
- Inui, T., Katsumi, T., Takai, A., Kamon, M., 2013. Factors affecting heavy metal leaching in excavated rocks with natural contamination. In: Manassero, M., et al. (Eds.), *Coupled Phenomena in Environmental Geotechnics*, Leeds, UK. CRC Press, pp. 587–592.
- Itaya, Y., Kikuchi, S., Yoshimatsu, T., Kuninishi, K., 2013. Clarification of insolubilization mechanism of heavy metals using magnesium/calcium composite material. In: *Proc of the 19th Conference on Groundwater and Soil Contamination and its Countermeasures*, Japan. (in Japanese).
- Itaya, Y., Kuninishi, K., 2019. Investigation of optimum firing degree of calcined dolomite used for insolubilization treatment of heavy metals

- and analysis on crystal structure change of dolomite by firing. *J. Soc. Mater. Sci. Japan* 68 (6), 470–477. <https://doi.org/10.2472/jmsms.68.470> (in Japanese).
- Ito, H., Katsumi, T., 2020. Leaching characteristics of naturally derived toxic elements from soils in the western Osaka area: considerations from the analytical results under the Soil Contamination Countermeasures Act. *Japanese Geotechn. J.* 15 (1), 119–130. <https://doi.org/10.3208/jgs.15.119> (in Japanese).
- JGS 0051, 2015. Method of classification of geomaterials for engineering purposes. Japanese Geotechnical Society.
- JIS A 1202, 2009. Test Method for Density of Soil Particles. Japanese Standards Association.
- JIS A 1204, 2009. Test Method for Particle Size Distribution of Soils. Japanese Standards Association.
- JIS A 1210, 2009. Test Method for Soil Compaction Using a Rammer. Japanese Standards Association.
- JIS R 5201, 2015. Physical Testing Methods for Cement. Japanese Standards Association.
- JIS R 9011, 2006. Test Method for Lime. Japanese Standards Association.
- Katsumi, T., 2015. Soil excavation and reclamation in civil engineering: environmental aspects. *Soil Sci. Plant Nutrit.* 61 (sup1), 22–29. <https://doi.org/10.1080/00380768.2015.1020506>.
- Katsumi, T., Inui, T., Kamon, M., 2010. Sustainable geotechnics for reuse of by-products. In: Manoj, D., et al. (Eds.), *Proceedings of the 6th International Congress on Environmental Geotechnics*, New Delhi, India, vol. 1. McGraw Hill, pp. 302–317.
- Katsumi, T., Inui, T., Yasutaka, T., Takai, A., 2019. Towards sustainable soil management—reuse of excavated soils with natural contamination—. In: Zhan, L. et al. (Eds.), *Proceedings of the 8th International Congress on Environmental Geotechnics*, Hangzhou, China, vol. 1. Springer, pp. 99–118. https://doi.org/10.1007/978-981-13-2221-1_5.
- Li, J., Kosugi, T., Riya, S., Hashimoto, Y., Hou, H., Terada, A., Hosomi, M., 2018. Pollution potential leaching index as a tool to assess water leaching risk of arsenic in excavated urban soils. *Ecotoxicol. Environ. Saf.* 147, 72–79. <https://doi.org/10.1016/j.ecoenv.2017.08.002>.
- Lide, D.R., 2001. *CRC Handbook of Chemistry and Physics*, eighty-second ed. Taylor & Francis.
- Lu, P., Zhu, C., 2011. Arsenic Eh-pH diagrams at 25°C and 1 bar. *Environ. Earth Sci.* 62 (8), 1673–1683. <https://doi.org/10.1007/s12665-010-0652-x>.
- Magnusson, S., Johansson, M., Frosth, S., Lundberg, K., 2019. Coordinating soil and rock material in urban construction—scenario analysis of material flows and greenhouse gas emissions. *J. Cleaner Prod.* 241, 118236. <https://doi.org/10.1016/j.jclepro.2019.118236>.
- McBride, M.B., 1994. *Environmental Chemistry of Soils*. Oxford University Press.
- McNeill, L.S., Edwards, M., 1997. Arsenic removal during precipitative softening. *J. Environ. Eng.* 123 (5), 453–460. [https://doi.org/10.1061/\(ASCE\)0733-9372\(1997\)123:5\(453\)](https://doi.org/10.1061/(ASCE)0733-9372(1997)123:5(453)).
- Ministry of Land, Infrastructure, and Transport, Japan, 2010. *Technical Manual on the Countermeasure for Soils and Rocks Containing Naturally Occurring Heavy Metals in Construction Works (Draft)*. <http://www.mlit.go.jp/sogoseisaku/region/recycle/recyclehou/manual/index.htm> (accessed 1 June 2020) (in Japanese).
- Mo, J., Flores, G., Inui, T., Katsumi, T., 2020. Hydraulic and sorption performances of soil amended with calcium-magnesium composite powder against natural arsenic contamination. *Soils Found.* 60 (5), 1084–1096. <https://doi.org/10.1016/j.sandf.2020.05.007>.
- Moon, D.H., Dermatas, D., Menounou, N., 2004. Arsenic immobilization by calcium-arsenic precipitates in lime treated soils. *Sci. Total Environ.* 330 (1), 171–185. <https://doi.org/10.1016/j.scitotenv.2004.03.016>.
- Nordstrom, D.K., 2011. Mine waters: acidic to circumneutral. *Elements* 7 (6), 393–398. <https://doi.org/10.2113/gselements.7.6.393>.
- Nozaki, F., Shimizu, Y., Ito, K., 2013a. Discussion on construction method of heavy metals adsorption layer. In: *Proceedings of the 19th Symposium on Groundwater and Soil Contamination and Countermeasures*, Kyoto, Japan (in Japanese).
- Nozaki, T., Matsuyama, Y., Sugiyama, A., Moriya, M., Komukai, Y., Nagase, T., 2013b. Fundamental study of soil materials for absorbent construction method using MgO material. In: *Proceedings of the 19th Symposium on Groundwater and Soil Contamination and Countermeasures*, Kyoto, Japan (in Japanese).
- Ogata, A., Banks, R.B., 1961. A solution of the differential equation of longitudinal dispersion in porous media. PP 411-A. <http://pubs.er.usgs.gov/publication/pp411A>.
- Paikaray, S., 2015. Arsenic geochemistry of acid mine drainage. *Mine Water Environ.* 34 (2), 181–196. <https://doi.org/10.1007/s10230-014-0286-4>.
- Salameh, Y., Albadarin, A.B., Allen, S., Walker, G., Ahmad, M.N.M., 2015. Arsenic(III, V) adsorption onto charred dolomite: charring optimization and batch studies. *Chem. Eng. J.* 259, 663–671. <https://doi.org/10.1016/j.cej.2014.08.038>.
- Shackelford, C.D., Sevick, G.W., Eykholt, G.R., 2010. Hydraulic conductivity of geosynthetic clay liners to tailings impoundment solutions. *Geotext. Geomembr.* 28 (2), 149–162. <https://doi.org/10.1016/j.geotextmem.2009.10.005>.
- Stumm, W., Morgan, J.J., 2012. *Aquatic Chemistry: Chemical Equilibria and Rates in Natural Waters*, third ed. Wiley.
- Tabelin, C.B., Igarashi, T., Tamoto, S., Takahashi, R., 2012. The roles of pyrite and calcite in the mobilization of arsenic and lead from hydrothermally altered rocks excavated in Hokkaido, Japan. *J. Geochem. Explor.* 119, 17–31. <https://doi.org/10.1016/j.gexplo.2012.06.003>.
- Tabelin, C.B., Igarashi, T., Arima, T., Sato, D., Tatsuhara, T., Tamoto, S., 2014. Characterization and evaluation of arsenic and boron adsorption onto natural geologic materials, and their application in the disposal of excavated altered rock. *Geoderma* 213, 163–172. <https://doi.org/10.1016/j.geoderma.2013.07.037>.
- Tabelin, C.B., Igarashi, T., Villacorte-Tabelin, M., Park, I., Opiso, E.M., Ito, M., Hiroyoshi, N., 2018. Arsenic, selenium, boron, lead, cadmium, copper, and zinc in naturally contaminated rocks: a review of their sources, modes of enrichment, mechanisms of release, and mitigation strategies. *Sci. Total Environ.* 645, 1522–1553. <https://doi.org/10.1016/j.scitotenv.2018.07.103>.
- Takahashi, T., Fujii, K., Igarashi, T., Kaketa, K., Yamada, N., 2011. Distribution and leaching properties of arsenic in hydrothermally altered rock of Nakakoshi area, central Hokkaido, Japan. *J. Japan Soc. Eng. Geol.* 52 (2), 46–54. <https://doi.org/10.5110/jjseg.52.46> (in Japanese).
- Tatsuhara, T., Arima, T., Igarashi, T., Tabelin, C.B., 2012. Combined neutralization-adsorption system for the disposal of hydrothermally altered excavated rock producing acidic leachate with hazardous elements. *Eng. Geol.* 139, 76–84. <https://doi.org/10.1016/j.enggeo.2012.04.006>.
- Tatsuhara, T., Jikihara, S., Tatsumi, T., Igarashi, T., 2015. Effects of the layout of adsorption layer on immobilizing arsenic leached from excavated rocks. *Japanese Geotech. J.* 10 (4), 635–640. <https://doi.org/10.3208/jgs.10.635> (in Japanese).
- The Society of Materials Science, Japan (JSMS), 2014. *Heavy metal insolubilization agent material ‘Magic Fix’*. Report No.1015 on Ground Improvement Technology Review and Certification (in Japanese).
- Ujii-Mikoshiba, M., Imai, N., Terashima, S., Tachibana, Y., Okai, T., 2006. Geochemical mapping in northern Honshu, Japan. *Appl. Geochem.* 21 (3), 492–514. <https://doi.org/10.1016/j.apgeochem.2005.12.002>.
- van Genuchten, M.T., Parker, J.C., 1984. Boundary conditions for displacement experiments through short laboratory soil columns. *Soil Sci. Soc. Am. J.* 48 (4), 703–708. <https://doi.org/10.2136/sssaj1984.03615995004800040002x>.